



Model created in COMSOL Multiphysics 6.4

Multitransformer Coil Above an Asymmetric Conductor Plate

Introduction

This model solves the Testing Electromagnetic Analysis Methods (TEAM) problem 7, “Asymmetrical Conductor with a Hole” — a benchmark problem concerning the calculation of eddy currents and magnetic fields produced when an aluminum conductor is placed asymmetrically above a multiturn coil carrying a sinusoidally varying current. The simulation results at specified positions in space are compared with measured data from the literature and agreement is shown.

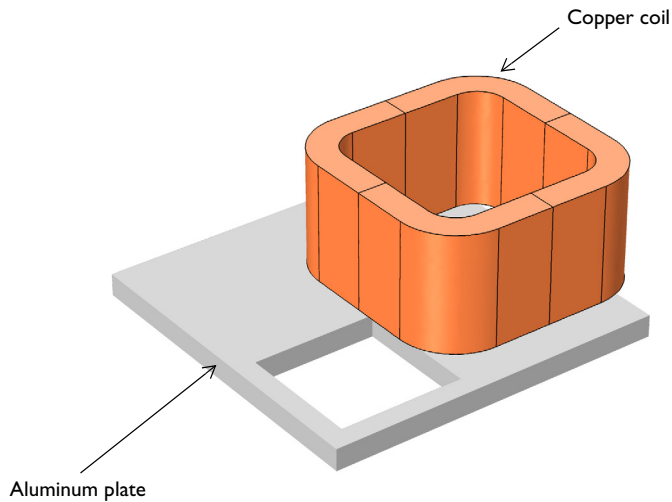

Figure 1: A multiturn coil placed asymmetrically over an aluminum plate with a hole.

Model Definition

Because the geometry has no symmetries, the problem must be solved for the entire geometry. As shown in [Figure 1](#), the geometry consists of a coil placed asymmetrically above a thick aluminum conductor with an eccentric square hole. The coil has 2742 turns and carries a sinusoidally varying current of 1 A/turn. The magnetic field and the eddy currents induced in the conductor for coil currents of frequencies 50 Hz and 200 Hz are calculated, and the simulation results along specified locations in space are compared with experimental data given in [Ref. 1](#).

Results and Discussion

Figure 2 visualizes the induced current at 50 Hz using a combined surface and arrow plot. The black arrows show the current density in the conductor while the red arrows indicate the coil current direction is shown. Figure 3 shows the corresponding results at 200 Hz.

freq(1)=50 Hz Arrow Volume: Coil direction Arrow Volume: Conduction current density Volume: Conduction current density, y-component (A/m²)

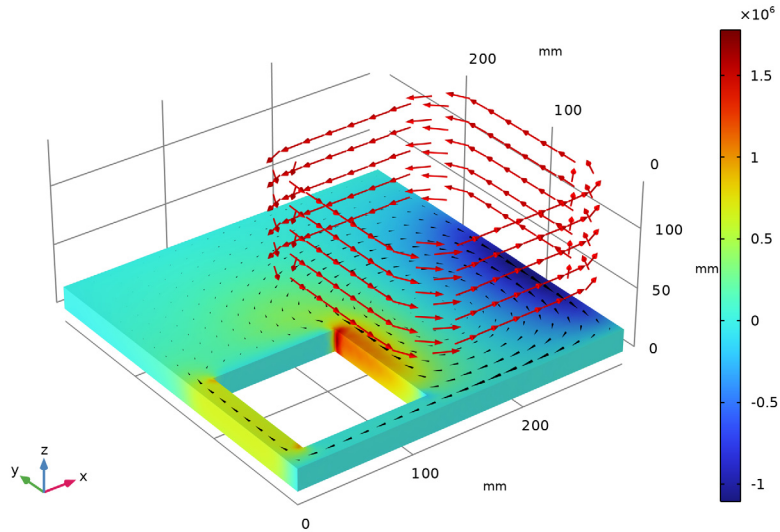

Figure 2: A 3D surface plot of the y-component of the induced current density, J_y (A/m²) in the conductor combined with the arrow volume plots of the coil current direction and the induced current density in the conductor. This simulation results are at 50 Hz.

freq(2)=200 Hz Arrow Volume: Coil direction Arrow Volume: Conduction current density Volume: Conduction current density, y-component (A/m²)

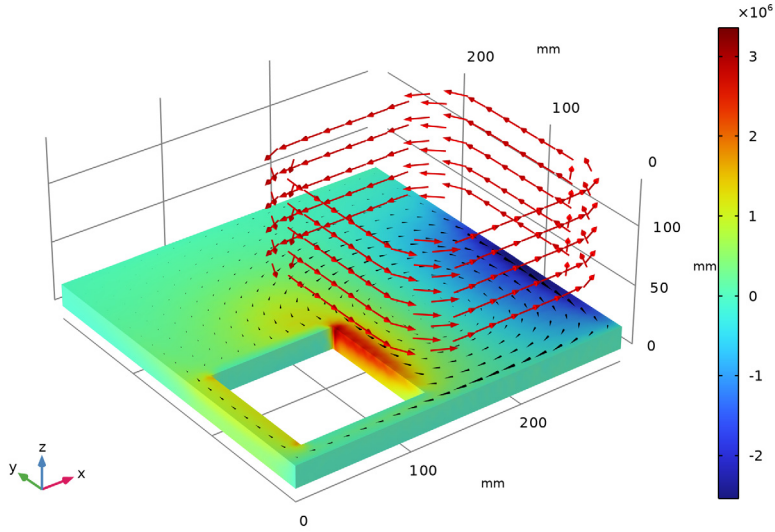

Figure 3: A 3D surface plot of the y-component of the induced current density in the conductor combined with the arrow volume plots of the coil current direction and the induced current density in the conductor. This simulation results are at 200 Hz.

Figure 4 and Figure 5 show comparisons between the simulation and the measured data. In Figure 4, the z-component of the magnetic flux density, B_z (SI unit: mT), at 50 Hz and 200 Hz are compared with measured data from Ref. 1. These results are compared for $0 \leq x \leq 288$ mm at $y = 72$ mm and $z = 34$ mm (a line between the aluminum plate and the copper coil). In Figure 5, similarly, the y-component values of the induced current density, J_y (SI unit: A/m²) at 50 Hz and 200 Hz are compared with the corresponding measured data. This is done at $0 \leq x \leq 288$ mm, $y = 72$ mm, and $z = 19$ mm (a line on the surface of the aluminum plate that crosses the gap). As is evident from the plots, there is close agreement between the simulation results and the measured data.

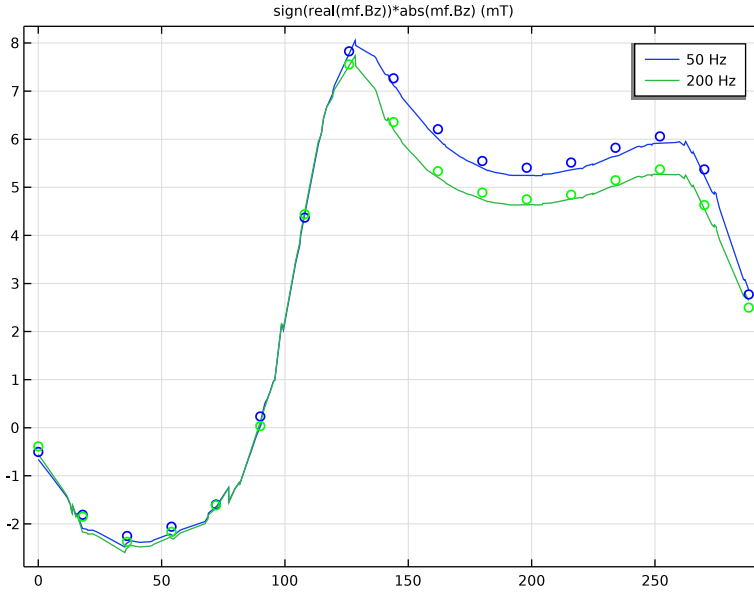

Figure 4: z -component of the flux density, B_z (mT), at $0 \leq x \leq 288$ mm, $y = 72$ mm, and $z = 34$ mm for 50 Hz and 200 Hz. The solid lines are simulation results while the circles are the corresponding measured data from Ref. 1.

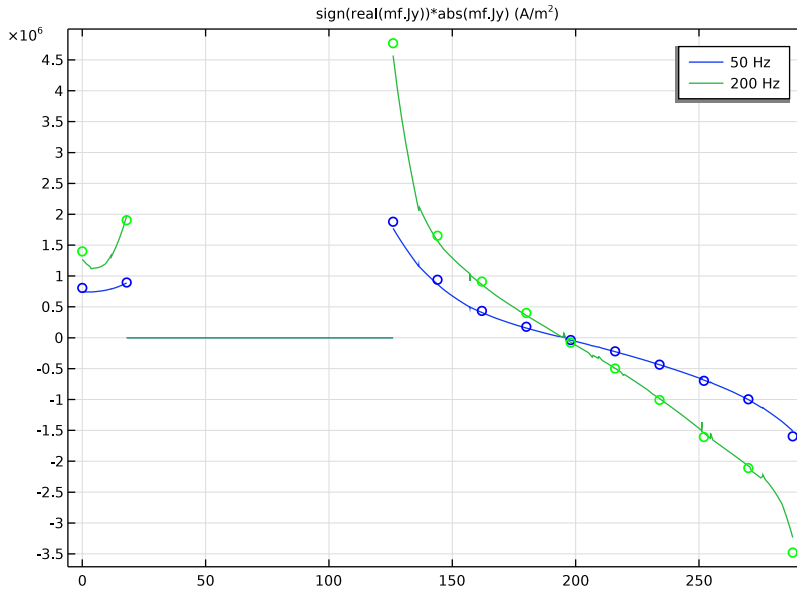

Figure 5: y -components of the induced current densities, J_y (A/m^2) for $0 \leq x \leq 288$ mm at $y = 72$ mm, $z = 19$ mm for 50 Hz and 200 Hz. The solid lines are simulation results while the circles are the corresponding measured data from Ref. 1.

Notes About the COMSOL Implementation

The direction of the wires in the coil is computed using a Coil feature combined with a Coil Geometry Analysis study step. The eddy currents and the nonuniform magnetic field are computed using a Frequency Domain study step for the frequencies 50 Hz and 200 Hz.

Reference

1. K. Fujiwara and T. Nakata, “Results for Benchmark Problem 7 (Asymmetrical Conductor with a Hole),” *Int. J. Comput. and Math. in Electr. and Electron. Eng.*, vol. 9, no. 3, pp. 137–154, 1990.

Application Library path: ACDC_Module/Verifications/
multiturn_coil_asymmetric_conductor



Modeling Instructions

From the **File** menu, choose **New**.

NEW



In the **New** window, click  **Model Wizard**.

MODEL WIZARD

- 1 In the **Model Wizard** window, click  **3D**.
- 2 In the **Select Physics** tree, select **AC/DC** > **Electromagnetic Fields** > **Magnetic Fields (mf)**.
- 3 Click **Add**.
- 4 Click  **Study**.
- 5 In the **Select Study** tree, select **Empty Study**.
- 6 Click  **Done**.

GEOMETRY I

Insert the geometry sequence provided in a separate file.

- 1 In the **Geometry** toolbar, click **Insert Sequence** and choose **Insert Sequence**.
- 2 Browse to the model's Application Libraries folder and double-click the file `multiturn_coil_asymmetric_conductor_geom_sequence.mph`.
- 3 In the **Geometry** toolbar, click  **Build All**.
- 4 Click the  **Zoom Extents** button in the **Graphics** toolbar.

The model geometry is now complete.

- 5 Click the  **Wireframe Rendering** button in the **Graphics** toolbar to get a better view of the interior parts.

6 In the **Model Builder** window, under **Component 1 (comp1)** click **Geometry 1**.

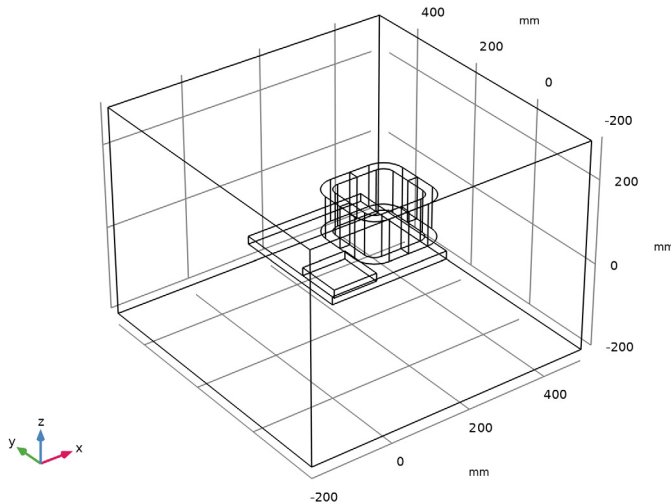



Conductor



Define domain and boundary selections for the coil and the conductor.

- 1 In the **Model Builder** window, under **Component 1 (comp1)** > **Geometry 1** click **Difference 1 (dif1)**.
- 2 In the **Settings** window for **Difference**, type Conductor in the **Label** text field.
- 3 Locate the **Selections of Resulting Entities** section. Select the **Resulting objects selection** checkbox.

Coil

- 1 In the **Model Builder** window, under **Component 1 (comp1)** > **Geometry 1** click **Extrude 1 (ext1)**.
- 2 In the **Settings** window for **Extrude**, type Coil in the **Label** text field.
- 3 Locate the **Selections of Resulting Entities** section. Select the **Resulting objects selection** checkbox.



Hide the outer geometry boundaries to visualize the results only in the coil and the conductor domains.
- 4 Click the  **Click and Hide** button in the **Graphics** toolbar.
- 5 In the **Graphics** window toolbar, click  next to  **Select Objects**, then choose **Select Boundaries**.

- 6 Select the exterior boundaries of the block (Boundaries 1–5 and 52).
- 7 Click the  **Click and Hide** button in the **Graphics** toolbar.
- 8 Click the  **Zoom Extents** button in the **Graphics** toolbar.

MAGNETIC FIELDS (MF)

Now set up the physics. Start by setting **Ampère's Law** to the aluminum plate.

Ampère's Law in Solids I

- 1 In the **Physics** toolbar, click  **Domains** and choose **Ampère's Law in Solids**.
- 2 In the **Settings** window for **Ampère's Law in Solids**, locate the **Domain Selection** section.
- 3 From the **Selection** list, choose **Conductor**.
- 4 In the **Model Builder** window, right-click **Magnetic Fields (mf)** and choose **Group by Space Dimension**.
- 5 Click the  **Zoom Extents** button in the **Graphics** toolbar.

Domain Coil I

- 1 In the **Physics** toolbar, click  **Domains** and choose **Domain Coil**.
- 2 In the **Settings** window for **Domain Coil**, locate the **Domain Selection** section.
- 3 From the **Selection** list, choose **Coil**.
- 4 Locate the **Coil** section. From the **Conductor model** list, choose **Homogenized multiturn**.
- 5 Locate the **Homogenized Conductor** section. In the N text field, type 2742.

Apply the input on a cross-sectional coil boundary.

Input I

- 1 In the **Model Builder** window, expand the **Component I (comp1) > Magnetic Fields (mf) > Domains > Domain Coil I > Geometry Analysis I** node, then click **Input I**.

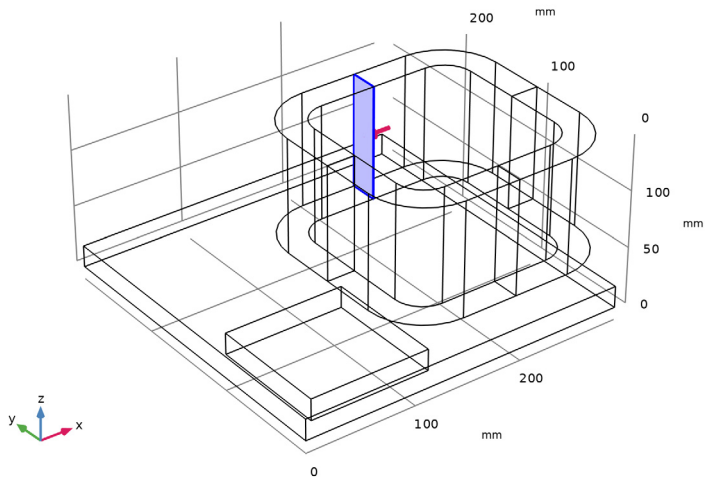

2 Select Boundary 37 only.



MATERIALS

Add material for the components.

ADD MATERIAL

- 1 In the **Materials** toolbar, click  **Add Material** to open the **Add Material** window.
- 2 Go to the **Add Material** window.
- 3 In the tree, select **AC/DC** > **Copper**.
- 4 Click the **Add to Component** button in the window toolbar.
- 5 In the **Materials** toolbar, click  **Add Material** to close the **Add Material** window.

MATERIALS

Copper (mat1)

- 1 In the **Settings** window for **Material**, locate the **Geometric Entity Selection** section.
- 2 From the **Selection** list, choose **Coil**.

Create a new material for the conductor. This will have the relevant properties of Aluminum

Aluminum

- 1 In the **Model Builder** window, right-click **Materials** and choose **Blank Material**.

- 2 In the **Settings** window for **Material**, locate the **Geometric Entity Selection** section.
- 3 From the **Selection** list, choose **Conductor**.
- 4 Locate the **Material Contents** section. In the table, enter the following settings:

Property	Variable	Value	Unit	Property group
Relative permeability	mur_iso ; murii = mur_iso, murij = 0	1		Basic
Electric conductivity	sigma_iso ; sigmai = sigma_iso, sigmaj = 0	3.526e7	S/m	Basic
Relative permittivity	epsilon_r_iso ; epsilon_rii = epsilon_r_iso, epsilon_rij = 0	1		Basic

- 5 In the **Label** text field, type Aluminum.

MESH 1

Use a finer mesh in the aluminum plate to better resolve the eddy currents and obtain a more accurate solution.

Size 1

- 1 In the **Model Builder** window, under **Component 1 (comp1)** right-click **Mesh 1** and choose **Size**.
- 2 In the **Settings** window for **Size**, locate the **Geometric Entity Selection** section.
- 3 From the **Geometric entity level** list, choose **Domain**.
- 4 From the **Selection** list, choose **Conductor**.
- 5 Locate the **Element Size** section. Click the **Custom** button.
- 6 Locate the **Element Size Parameters** section.
- 7 Select the **Maximum element size** checkbox. In the associated text field, type 12.

Size 2

- 1 In the **Model Builder** window, right-click **Mesh 1** and choose **Size**.
- 2 In the **Settings** window for **Size**, locate the **Geometric Entity Selection** section.
- 3 From the **Geometric entity level** list, choose **Domain**.

- 4 From the **Selection** list, choose **Coil**.
- 5 Locate the **Element Size** section. Click the **Custom** button.
- 6 Locate the **Element Size Parameters** section.
- 7 Select the **Maximum element size** checkbox. In the associated text field, type 20.

Free Tetrahedral 1

- 1 In the **Mesh** toolbar, click  **Free Tetrahedral**.
- 2 In the **Settings** window for **Free Tetrahedral**, click  **Build Selected**.

The mesh should look like that shown in the figure below.

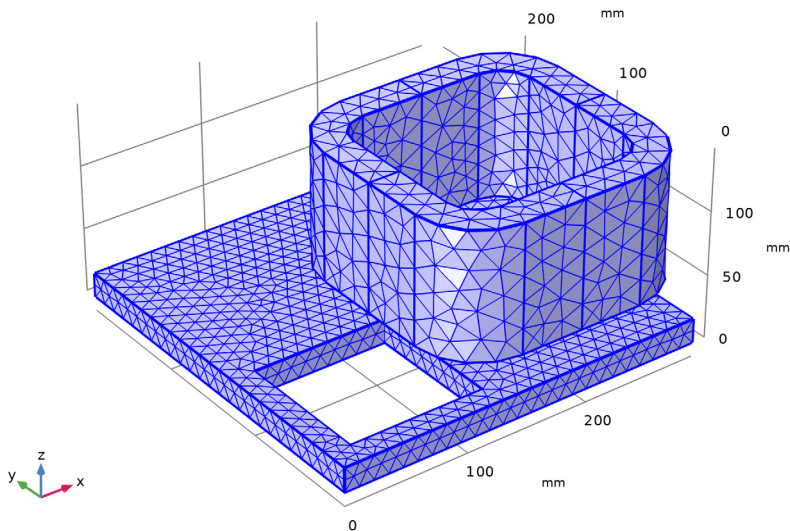

STUDY 1

Next, set up the study. Start by adding a **Coil Geometry Analysis** preprocessing study step before the Frequency Domain step.



Step 1: Coil Geometry Analysis

- 1 In the **Study** toolbar, click  **More Study Steps** and choose **Other > Coil Geometry Analysis**.

This study step computes the direction of the wires in the coils.

Add the main Frequency Domain study step. Solve the problem in the frequency domain for 50 Hz and 200 Hz.

Step 2: Frequency Domain

- 1 In the **Study** toolbar, click  **Frequency Domain**.
- 2 In the **Settings** window for **Frequency Domain**, locate the **Study Settings** section.
- 3 In the **Frequencies** text field, type 50 200.
- 4 In the **Model Builder** window, click **Study 1**.
- 5 In the **Settings** window for **Study**, locate the **Study Settings** section.
- 6 Clear the **Generate default plots** checkbox.
- 7 In the **Study** toolbar, click  **Compute**.

RESULTS

To reproduce the plot shown in [Figure 2](#), create a 3D plot group and add an Arrow Volume plot of the coil current direction in the coil domain, computed by the Coil Geometry Analysis step. Add an Arrow Volume plot of the induced current on the conductor surface and a Volume plot of the y component of the induced current density to the same plot group.

Coil Direction and Induced Current Density, 50 Hz

- 1 In the **Model Builder** window, expand the **Results** node.
- 2 Right-click **Results** and choose **3D Plot Group**.
- 3 In the **Settings** window for **3D Plot Group**, type Coil Direction and Induced Current Density, 50 Hz in the **Label** text field.
- 4 Locate the **Data** section. From the **Parameter value (freq (Hz))** list, choose **50**.

Arrow Volume 1

Right-click **Coil Direction and Induced Current Density, 50 Hz** and choose **Arrow Volume**.

Selection 1

- 1 In the **Model Builder** window, right-click **Arrow Volume 1** and choose **Selection**.
- 2 In the **Settings** window for **Selection**, locate the **Selection** section.
- 3 From the **Selection** list, choose **Coil**.

Arrow Volume 1

- 1 In the **Model Builder** window, click **Arrow Volume 1**.

- 2 In the **Settings** window for **Arrow Volume**, click **Replace Expression** in the upper-right corner of the **Expression** section. From the menu, choose **Component I (compI) > Magnetic Fields > Coil parameters > mf.coil.eCoilx,...,mf.coil.eCoilz - Coil direction**.
- 3 Locate the **Arrow Positioning** section. Find the **x grid points** subsection. In the **Points** text field, type 10.
- 4 Find the **y grid points** subsection. In the **Points** text field, type 10.
- 5 Find the **z grid points** subsection. In the **Points** text field, type 5.
- 6 Locate the **Coloring and Style** section.
- 7 Select the **Scale factor** checkbox. In the associated text field, type 20.

Arrow Volume 2

In the **Model Builder** window, right-click **Coil Direction and Induced Current Density, 50 Hz** and choose **Arrow Volume**.

Selection 1

- 1 In the **Model Builder** window, right-click **Arrow Volume 2** and choose **Selection**.
- 2 In the **Settings** window for **Selection**, locate the **Selection** section.
- 3 From the **Selection** list, choose **Conductor**.

Arrow Volume 2

- 1 In the **Model Builder** window, click **Arrow Volume 2**.
- 2 In the **Settings** window for **Arrow Volume**, click **Replace Expression** in the upper-right corner of the **Expression** section. From the menu, choose **Component I (compI) > Magnetic Fields > Currents and charge > mf.Jix,...,mf.Jiz - Conduction current density**.
- 3 Locate the **Arrow Positioning** section. Find the **x grid points** subsection. In the **Points** text field, type 20.
- 4 Find the **y grid points** subsection. In the **Points** text field, type 20.
- 5 Find the **z grid points** subsection. From the **Entry method** list, choose **Coordinates**.
- 6 In the **Coordinates** text field, type 19.
- 7 Locate the **Coloring and Style** section. From the **Color** list, choose **Black**.
- 8 From the **Arrow type** list, choose **Cone**.

Volume 1

In the **Model Builder** window, right-click **Coil Direction and Induced Current Density, 50 Hz** and choose **Volume**.

Selection 1

- 1 In the **Model Builder** window, right-click **Volume 1** and choose **Selection**.
- 2 In the **Settings** window for **Selection**, locate the **Selection** section.
- 3 From the **Selection** list, choose **Conductor**.

Volume 1

- 1 In the **Model Builder** window, click **Volume 1**.
- 2 In the **Settings** window for **Volume**, click **Replace Expression** in the upper-right corner of the **Expression** section. From the menu, choose **Component 1 (comp1) > Magnetic Fields > Currents and charge > Conduction current density - A/m² > mf.jiy - Conduction current density, y-component**.

Coil Direction and Induced Current Density, 50 Hz

- 1 In the **Model Builder** window, click **Coil Direction and Induced Current Density, 50 Hz**.
- 2 In the **Settings** window for **3D Plot Group**, locate the **Plot Settings** section.
- 3 Clear the **Plot dataset edges** checkbox.
- 4 In the **Coil Direction and Induced Current Density, 50 Hz** toolbar, click  **Plot**.

Duplicate the plot group just created and modify the copy to generate the plot shown in [Figure 3](#). This figure is similar to the [Figure 2](#) except the frequency is 200 Hz.

Coil Direction and Induced Current Density, 200 Hz

- 1 Right-click **Coil Direction and Induced Current Density, 50 Hz** and choose **Duplicate**.
- 2 In the **Settings** window for **3D Plot Group**, type **Coil Direction and Induced Current Density, 200 Hz** in the **Label** text field.
- 3 Locate the **Data** section. From the **Parameter value (freq (Hz))** list, choose **200**.
- 4 In the **Coil Direction and Induced Current Density, 200 Hz** toolbar, click  **Plot**.

To generate the plots shown in [Figure 4](#) and [Figure 5](#), begin by creating two cut line datasets.

Cut Line 3D 1

- 1 In the **Results** toolbar, click  **Cut Line 3D**.
- 2 In the **Settings** window for **Cut Line 3D**, locate the **Line Data** section.
- 3 In row **Point 1**, set **y** to 72 and **z** to 34.
- 4 In row **Point 2**, set **x** to 288, **y** to 72, and **z** to 34.

Cut Line 3D 2

1 Right-click **Cut Line 3D 1** and choose **Duplicate**.

Specify a value of z slightly below the surface of the conductor.

2 In the **Settings** window for **Cut Line 3D**, locate the **Line Data** section.

3 In row **Point 1**, set z to 18.99.

4 In row **Point 2**, set z to 18.99.

Import the experimental data of B_z and J_y in two tables.

Table 1

1 In the **Results** toolbar, click  **Table**.

2 In the **Settings** window for **Table**, locate the **Data** section.

3 Click  **Import**.

4 Browse to the model's Application Libraries folder and double-click the file `multiturn_coil_asymmetric_conductor_table1.txt`.

5 Locate the **Column Headers** section. In the table, enter the following settings:

Column	Header
1	x [mm]
2	$B_z(x, 72, 34)$ at 50Hz
3	$B_z(x, 72, 34)$ at 200Hz

Table 2

1 In the **Results** toolbar, click  **Table**.

2 In the **Settings** window for **Table**, locate the **Data** section.

3 Click  **Import**.

4 Browse to the model's Application Libraries folder and double-click the file `multiturn_coil_asymmetric_conductor_table2.txt`.

5 Locate the **Column Headers** section. In the table, enter the following settings:

Column	Header
1	x [mm]
2	$J_y(x, 72, 19)$ at 50Hz
3	$J_y(x, 72, 19)$ at 200Hz

Plot the z -component of the magnetic flux density, B_z , along the lines defined by the cut line datasets just created.

ID Plot Group 3

In the **Results** toolbar, click  **ID Plot Group**.

Line Graph 1

- 1 Right-click **ID Plot Group 3** and choose **Line Graph**.
- 2 In the **Settings** window for **Line Graph**, locate the **Data** section.
- 3 From the **Dataset** list, choose **Cut Line 3D 1**.
- 4 From the **Solution parameters** list, choose **From parent**.
- 5 Locate the **y-Axis Data** section. In the **Expression** text field, type $\text{sign}(\text{real}(\text{mf} \cdot B_z)) * \text{abs}(\text{mf} \cdot B_z)$.
- 6 From the **Unit** list, choose **mT**.
- 7 Click to expand the **Legends** section. Select the **Show legends** checkbox.
- 8 From the **Legends** list, choose **Evaluated**.
- 9 In the **Legend** text field, type $\text{eval}(\text{freq}) \text{ Hz}$.

Bz(x,72,34)

Add a plot for the experimental value of B_z at 50 Hz to the same plot group using a table graph.

- 1 In the **Model Builder** window, under **Results** click **ID Plot Group 3**.
- 2 In the **Settings** window for **ID Plot Group**, type $B_z(x, 72, 34)$ in the **Label** text field.

Table Graph 1

- 1 Right-click **Bz(x,72,34)** and choose **Table Graph**.
- 2 In the **Settings** window for **Table Graph**, locate the **Data** section.
- 3 From the **x-axis data** list, choose **x [mm]**.
- 4 From the **Plot columns** list, choose **Manual**.
- 5 In the **Columns** list box, select **Bz(x,72,34) at 50Hz**.
- 6 Locate the **Coloring and Style** section. Find the **Line style** subsection. From the **Line** list, choose **None**.
- 7 From the **Color** list, choose **Blue**.
- 8 Find the **Line markers** subsection. From the **Marker** list, choose **Circle**.

Duplicate the table graph previously created and modify to plot the experimental value of B_z at 200 Hz.

Table Graph 2

- 1 Right-click **Table Graph 1** and choose **Duplicate**.

- 2 In the **Settings** window for **Table Graph**, locate the **Data** section.
- 3 In the **Columns** list box, select **Bz(x,72,34) at 200Hz**.
- 4 Locate the **Coloring and Style** section. From the **Color** list, choose **Green**.
- 5 In the **Bz(x,72,34)** toolbar, click  **Plot**.

Compare the resulting plot with that in [Figure 4](#).

Plot the y -component of the current density on the surface of the conductor, J_y , along the line specified earlier. Use an approach similar to the one used to generate [Figure 4](#).

ID Plot Group 4

In the **Results** toolbar, click  **ID Plot Group**.

Line Graph 1

- 1 Right-click **ID Plot Group 4** and choose **Line Graph**.
- 2 In the **Settings** window for **Line Graph**, locate the **Data** section.
- 3 From the **Dataset** list, choose **Cut Line 3D 2**.
- 4 From the **Solution parameters** list, choose **From parent**.
- 5 Locate the **y-Axis Data** section. In the **Expression** text field, type `sign(real(mf.Jy))*abs(mf.Jy)`.
- 6 Locate the **Legends** section. Select the **Show legends** checkbox.
- 7 From the **Legends** list, choose **Evaluated**.
- 8 In the **Legend** text field, type `eval(freq) Hz`.

Jy(x,72,19)

- 1 In the **Model Builder** window, under **Results** click **ID Plot Group 4**.
- 2 In the **Settings** window for **ID Plot Group**, type $J_y(x, 72, 19)$ in the **Label** text field.

Table Graph 1

- 1 Right-click **Jy(x,72,19)** and choose **Table Graph**.
- 2 In the **Settings** window for **Table Graph**, locate the **Data** section.
- 3 From the **Table** list, choose **Table 2**.
- 4 From the **x-axis data** list, choose **x [mm]**.
- 5 From the **Plot columns** list, choose **Manual**.
- 6 In the **Columns** list box, select **Jy(x,72,19) at 50Hz**.
- 7 Locate the **Coloring and Style** section. Find the **Line style** subsection. From the **Line** list, choose **None**.

- 8 From the **Color** list, choose **Blue**.
- 9 Find the **Line markers** subsection. From the **Marker** list, choose **Circle**.

Table Graph 2

- 1 Right-click **Table Graph 1** and choose **Duplicate**.
- 2 In the **Settings** window for **Table Graph**, locate the **Data** section.
- 3 In the **Columns** list box, select **Jy(x,72,19) at 200Hz**.
- 4 Locate the **Coloring and Style** section. From the **Color** list, choose **Green**.
- 5 In the **Jy(x,72,19)** toolbar, click  **Plot**. This plot reproduces [Figure 5](#).