



Model created in COMSOL Multiphysics 6.4

Magnetohydrodynamics Pump

Introduction

When an electrically conducting media is exposed to a time-varying magnetic field, eddy currents are induced that will counteract the change of magnetic flux and create a repelling force on the material. This magnetohydrodynamical principle can be utilized to create pumping action on a conducting liquid in a hermetically sealed column, without having to use moving parts.

Model Definition

The model is set up in a 2D axisymmetric geometry using the **Magnetic Fields** and **Laminar Flow** physics interfaces, coupled via the **Magneto hydrodynamics** multiphysics interface.

The model coupling relies on separate study types for the two physics interfaces, where the Magnetic Fields is solved in the frequency domain and the Laminar Flow is solved in the stationary domain. The cycle-averaged Lorentz force is employed in the fluid flow, and conversely the phase-dependent electromotive force is employed in the electromagnetic calculation. The cycle-averaged force on the liquid will be in the direction of the phase velocity of the magnetic field, where the latter is induced with a 3-phase coil setup. At both ends of the flow column there is a periodic condition for the pressure, fluid velocity, and magnetic vector potential, emulating an infinitely extended pump setup.

Results

[Figure 1](#) shows the magnetic flux density norm on the 2D axisymmetric cross section of the pump.

[Figure 2](#) shows the magnetic flux density as well as the fluid velocity norm on the partially revolved 2D axisymmetric geometry, with domain deformation illustrating the magnitude and direction of the fluid flow in the liquid column.

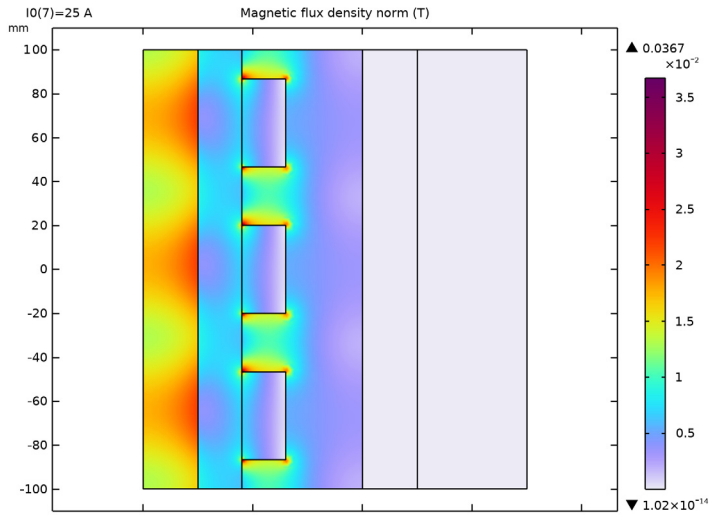

Figure 1: The magnetic flux density norm plotted on the 2D axisymmetric cross section of the pump.

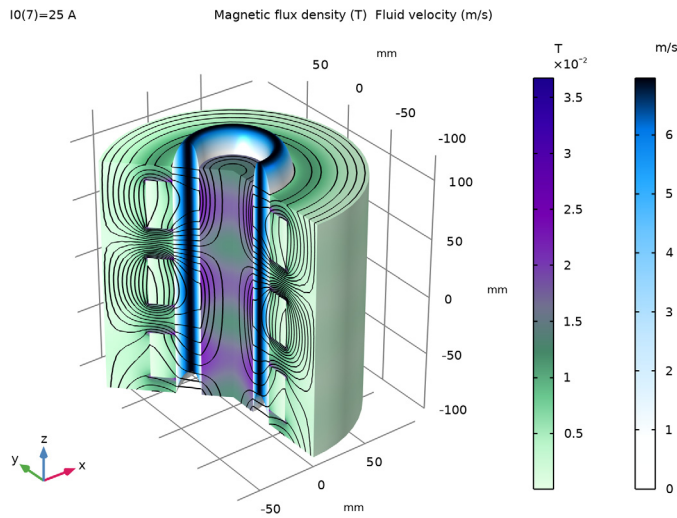



Figure 2: The velocity norm and the magnetic flux density norm plotted on the partially revolved 2D axisymmetric geometry.

Application Library path: ACDC_Module/Electromagnetics_and_Fluids/
magnetohydrodynamics_pump



Modeling Instructions

From the **File** menu, choose **New**.

NEW

In the **New** window, click  **Model Wizard**.

MODEL WIZARD

- 1 In the **Model Wizard** window, click  **2D Axisymmetric**.
- 2 In the **Select Physics** tree, select **AC/DC > Electromagnetics and Fluids > Magnetohydrodynamics, Out-of-Plane Currents**.
- 3 Click **Add**.
- 4 Click  **Study**.
- 5 In the **Select Study** tree, select **Preset Studies for Selected Multiphysics > Frequency–Stationary**.
- 6 Click  **Done**.

GLOBAL DEFINITIONS

Parameters I

- 1 In the **Model Builder** window, under **Global Definitions** click **Parameters I**.
- 2 In the **Settings** window for **Parameters**, locate the **Parameters** section.
- 3 In the table, enter the following settings:

Name	Expression	Value	Description
N	10	10	number or turns in coils
I0	1[A]	1 A	coil current magnitude
I1	$I0 \cdot \exp(-i \cdot 120[\text{deg}])$	(-0.5-0.86603i) A	phase 1
I2	I0	1 A	phase 2
I3	$I0 \cdot \exp(i \cdot 120[\text{deg}])$	(-0.5+0.86603i) A	phase 3

GEOMETRY 1

- 1 In the **Model Builder** window, under **Component 1 (comp1)** click **Geometry 1**.
- 2 In the **Settings** window for **Geometry**, locate the **Units** section.
- 3 From the **Length unit** list, choose **mm**.
- 4 Locate the **Advanced** section. From the **Default repair tolerance** list, choose **Relative**.



Rectangle 1 (r1)

- 1 In the **Geometry** toolbar, click  **Rectangle**.
- 2 In the **Settings** window for **Rectangle**, locate the **Size and Shape** section.
- 3 In the **Width** text field, type 175.
- 4 In the **Height** text field, type 200.
- 5 Locate the **Position** section. In the **z** text field, type -100.
- 6 Click to expand the **Layers** section. In the table, enter the following settings:

Layer name	Thickness (mm)
Layer 1	50

- 7 Select the **Layers to the right** checkbox.
- 8 Clear the **Layers on bottom** checkbox.
- 9 Click  **Build Selected**.

Rectangle 2 (r2)

- 1 In the **Geometry** toolbar, click  **Rectangle**.
- 2 In the **Settings** window for **Rectangle**, locate the **Size and Shape** section.
- 3 In the **Width** text field, type 100.
- 4 In the **Height** text field, type 200.
- 5 Locate the **Position** section. In the **z** text field, type -100.
- 6 Click  **Build Selected**.

Rectangle 3 (r3)

- 1 In the **Geometry** toolbar, click  **Rectangle**.
- 2 In the **Settings** window for **Rectangle**, locate the **Size and Shape** section.
- 3 In the **Width** text field, type 20.
- 4 In the **Height** text field, type 200.
- 5 Locate the **Position** section. In the **r** text field, type 25.
- 6 In the **z** text field, type -100.

7 Click  **Build Selected**.

Rectangle 4 (r4)

1 In the **Geometry** toolbar, click  **Rectangle**.

2 In the **Settings** window for **Rectangle**, locate the **Size and Shape** section.

3 In the **Width** text field, type 20.

4 In the **Height** text field, type 40.

5 Locate the **Position** section. From the **Base** list, choose **Center**.

6 In the **r** text field, type 55.

7 Click  **Build Selected**.

Copy 1 (copy1)

1 In the **Geometry** toolbar, click  **Transforms** and choose **Copy**.

2 Select the object **r4** only.

3 In the **Settings** window for **Copy**, locate the **Displacement** section.

4 In the **z** text field, type $2*100/3$.

5 Click  **Build Selected**.

Copy 2 (copy2)

1 In the **Geometry** toolbar, click  **Transforms** and choose **Copy**.

2 Select the object **r4** only.

3 In the **Settings** window for **Copy**, locate the **Displacement** section.

4 In the **z** text field, type $-2*100/3$.

5 Click  **Build Selected**.

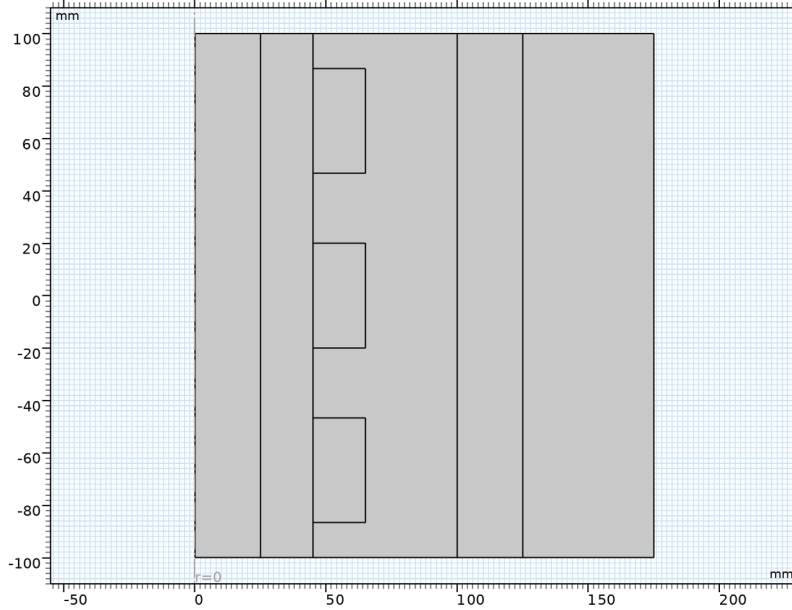

DEFINITIONS

Infinite Element Domain 1 (ie1)

1 In the **Definitions** toolbar, click  **Infinite Element Domain**.

2 Select Domain 8 only.

3 In the **Settings** window for **Infinite Element Domain**, locate the **Geometry** section.

4 From the **Type** list, choose **Cylindrical**.

LAMINAR FLOW (SPF)

1 In the **Model Builder** window, under **Component 1 (comp1)** click **Laminar Flow (spf)**.

2 In the **Settings** window for **Laminar Flow**, locate the **Domain Selection** section.

3 Click  **Clear Selection**.

4 Select Domain 2 only.

ADD MATERIAL

1 In the **Home** toolbar, click  **Add Material** to open the **Add Material** window.

2 Go to the **Add Material** window.

- 3 In the tree, select **Built-in > Copper**.
- 4 Click the **Add to Component** button in the window toolbar.

MATERIALS

Copper (mat1)

Select Domains 4–6 only.

Iron

- 1 In the **Model Builder** window, right-click **Materials** and choose **Blank Material**.
- 2 In the **Settings** window for **Material**, type Iron in the **Label** text field.
- 3 Select Domains 1 and 3 only.
- 4 Locate the **Material Contents** section. In the table, enter the following settings:

Property	Variable	Value	Unit	Property group
Relative permeability	mur_iso ; murii = mur_iso, murij = 0	1e3		Basic
Electric conductivity	sigma_iso ; sigmair = sigma_iso, sigmairj = 0	0	S/m	Basic
Relative permittivity	epsilononr_iso ; epsilononrii = epsilononr_iso, epsilononrij = 0	1		Basic

ADD MATERIAL

- 1 Go to the **Add Material** window.
- 2 In the tree, select **AC/DC > Liquid Metals > Lithium, 200 °C**.
- 3 Click the **Add to Component** button in the window toolbar.
- 4 In the **Materials** toolbar, click  **Add Material** to close the **Add Material** window.

MATERIALS

Lithium, 200 °C (mat3)

Select Domain 2 only.

The Ampère's Law in Fluids feature is used for the liquid lithium. An Ampère's Law in Solids feature is then used for the surrounding iron region.

MAGNETIC FIELDS (MF)

Ampère's Law in Fluids 1

1 In the **Model Builder** window, under **Component 1 (comp1) > Magnetic Fields (mf)** click **Ampère's Law in Fluids 1**.

2 Select Domain 2 only.

Ampère's Law in Solids 1

1 In the **Physics** toolbar, click  **Domains** and choose **Ampère's Law in Solids**.

2 Select Domains 1 and 3 only.

Periodic Condition 1

1 In the **Physics** toolbar, click  **Boundaries** and choose **Periodic Condition**.

2 In the **Settings** window for **Periodic Condition**, locate the **Boundary Selection** section.

3 Click  **Paste Selection**.

4 In the **Paste Selection** dialog, type 2, 3, 5, 6, 8, 21, 26, 27, 29, 30 in the **Selection** text field.

5 Click **OK**.

Multi-Turn Coil 1

1 In the **Physics** toolbar, click  **Domains** and choose **Domain Coil**.

2 In the **Settings** window for **Domain Coil**, type Multi-Turn Coil 1 in the **Label** text field.

3 Locate the **Domain Selection** section. Click  **Paste Selection**.

4 In the **Paste Selection** dialog, type 6 in the **Selection** text field.

5 Click **OK**.

6 In the **Settings** window for **Domain Coil**, locate the **Coil** section.

7 From the **Conductor model** list, choose **Homogenized multiturn**.

8 In the I_{coil} text field, type I1.

9 Locate the **Homogenized Conductor** section. In the N text field, type N.

Multi-Turn Coil 2

1 Right-click **Multi-Turn Coil 1** and choose **Duplicate**.



- 2 In the **Settings** window for **Domain Coil**, type Multi- Turn Coil 2 in the **Label** text field.
- 3 Locate the **Domain Selection** section. Click  **Clear Selection**.
- 4 Select Domain 5 only.
- 5 Locate the **Coil** section. In the I_{coil} text field, type I2.

Multi- Turn Coil 3



- 1 Right-click **Multi- Turn Coil 2** and choose **Duplicate**.
- 2 In the **Settings** window for **Domain Coil**, type Multi- Turn Coil 3 in the **Label** text field.
- 3 Locate the **Domain Selection** section. Click  **Clear Selection**.
- 4 Select Domain 4 only.
- 5 Locate the **Coil** section. In the I_{coil} text field, type I3.

LAMINAR FLOW (SPF)

Pressure Point Constraint 1

- 1 In the **Physics** toolbar, click  **Points** and choose **Pressure Point Constraint**.
- 2 In the **Settings** window for **Pressure Point Constraint**, locate the **Point Selection** section.
- 3 Click  **Paste Selection**.
- 4 In the **Paste Selection** dialog, type 4 in the **Selection** text field.
- 5 Click **OK**.

Periodic Flow Condition 1

- 1 In the **Physics** toolbar, click  **Boundaries** and choose **Periodic Flow Condition**.
- 2 In the **Settings** window for **Periodic Flow Condition**, locate the **Boundary Selection** section.
- 3 Click  **Paste Selection**.
- 4 In the **Paste Selection** dialog, type 5-6 in the **Selection** text field.
- 5 Click **OK**.

MULTIPHYSICS

Magnetohydrodynamics 1 (mhd1)

- 1 In the **Model Builder** window, under **Component 1 (comp1) > Multiphysics** click **Magnetohydrodynamics 1 (mhd1)**.
- 2 In the **Settings** window for **Magnetohydrodynamics**, locate the **Domain Selection** section.

3 Click  **Clear Selection.**

4 Select Domain 2 only.

MESH 1

Customize the mesh sequence to get adequate detail in the areas of interest.

1 In the **Model Builder** window, under **Component 1 (comp1)** click **Mesh 1**.

2 In the **Settings** window for **Mesh**, locate the **Sequence Type** section.

3 From the list, choose **User-controlled mesh**.

Size

1 In the **Model Builder** window, under **Component 1 (comp1)** > **Mesh 1** click **Size**.

2 In the **Settings** window for **Size**, locate the **Element Size** section.

3 From the **Predefined** list, choose **Finer**.

4 Click  **Build Selected.**

Size 1

1 In the **Model Builder** window, click **Size 1**.

2 In the **Settings** window for **Size**, locate the **Element Size** section.

3 From the **Predefined** list, choose **Extra fine**.

4 Click  **Build Selected.**

Size 2

In the **Model Builder** window, right-click **Size 2** and choose **Delete**.

Size 3

Right-click **Size 3** and choose **Delete**.

Distribution 1

1 In the **Model Builder** window, under **Component 1 (comp1)** > **Mesh 1** click **Distribution 1**.

2 In the **Settings** window for **Distribution**, locate the **Boundary Selection** section.

3 Click  **Clear Selection.**

4 Click  **Paste Selection.**

5 In the **Paste Selection** dialog, type 5-6 in the **Selection** text field.

6 Click **OK**.

7 In the **Settings** window for **Distribution**, locate the **Distribution** section.

8 In the **Number of elements** text field, type 40.

- 9 In the **Element ratio** text field, type 25.
- 10 Select the **Symmetric distribution** checkbox.
- 11 Click  **Build Selected**.

Mapped 2

- 1 In the **Mesh** toolbar, click  **Mapped**.
- 2 In the **Settings** window for **Mapped**, locate the **Domain Selection** section.
- 3 From the **Geometric entity level** list, choose **Domain**.
- 4 Select Domain 2 only.
- 5 Click to expand the **Reduce Element Skewness** section. Select the **Adjust edge mesh** checkbox.



Size 1

- 1 Right-click **Mapped 2** and choose **Size**.
- 2 In the **Settings** window for **Size**, locate the **Element Size** section.
- 3 From the **Predefined** list, choose **Extremely fine**.

Corner Refinement 1

In the **Model Builder** window, under **Component 1 (comp1) > Mesh 1** right-click **Corner Refinement 1** and choose **Delete**.

Free Triangular 1

- 1 In the **Settings** window for **Free Triangular**, locate the **Domain Selection** section.
- 2 In the list box, select **2**.
- 3 Click  **Remove from Selection**.
- 4 Select Domains 1 and 3–7 only.
- 5 Click  **Build Selected**.

Mapped 1

- 1 In the **Model Builder** window, click **Mapped 1**.
- 2 In the **Settings** window for **Mapped**, locate the **Domain Selection** section.
- 3 From the **Geometric entity level** list, choose **Remaining**.
- 4 Click  **Build Selected**.

Boundary Layers 1

In the **Model Builder** window, right-click **Boundary Layers 1** and choose **Delete**.

Mapped 1

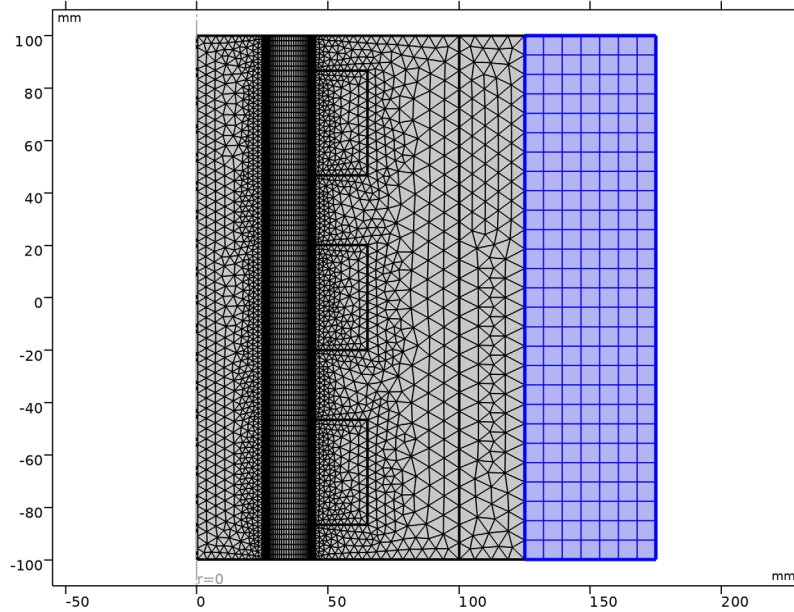

STUDY 1

Step 1: Frequency–Stationary





- 1 In the **Model Builder** window, under **Study 1** click **Step 1: Frequency–Stationary**.
- 2 In the **Settings** window for **Frequency–Stationary**, locate the **Study Settings** section.
- 3 In the **Frequency** text field, type 50.
- 4 Click to expand the **Study Extensions** section. Select the **Auxiliary sweep** checkbox.
- 5 Click **+ Add**.
- 6 In the table, enter the following settings:

Parameter name	Parameter value list	Parameter unit
10 (coil current magnitude)	0.1 1 5 10 15 20 25	A

- 7 In the table, click to select the cell at row number 1 and column number 3.
- 8 From the **Run continuation for** list, choose **No parameter**.
- 9 From the **Reuse solution from previous step** list, choose **Yes**.

This study uses separate segregated steps; one for the magnetic flux and one for the pressure and velocity.

Solution 1 (sol1)

- 1 In the **Study** toolbar, click  **Show Default Solver**.
- 2 In the **Model Builder** window, expand the **Solution 1 (sol1)** node.
- 3 In the **Model Builder** window, expand the **Study 1 > Solver Configurations > Solution 1 (sol1) > Stationary Solver 1** node.
- 4 Right-click **Study 1 > Solver Configurations > Solution 1 (sol1) > Stationary Solver 1** and choose **Segregated**.
- 5 In the **Model Builder** window, expand the **Study 1 > Solver Configurations > Solution 1 (sol1) > Stationary Solver 1 > Segregated 1** node, then click **Segregated Step**.
- 6 In the **Settings** window for **Segregated Step**, locate the **General** section.
- 7 In the **Variables** list, choose **Pressure (comp1.p)** and **Velocity Field (comp1.u)**.
- 8 Under **Variables**, click  **Delete**.
- 9 In the **Model Builder** window, under **Study 1 > Solver Configurations > Solution 1 (sol1) > Stationary Solver 1** right-click **Segregated 1** and choose **Segregated Step**.
- 10 In the **Settings** window for **Segregated Step**, locate the **General** section.
- 11 Under **Variables**, click  **Add**.
- 12 In the **Add** dialog, in the **Variables** list, choose **Pressure (comp1.p)** and **Velocity Field (comp1.u)**.
- 13 Click **OK**.
- 14 In the **Settings** window for **Segregated Step**, click to expand the **Method and Termination** section.
- 15 In the **Damping factor** text field, type 0.5.
- 16 In the **Study** toolbar, click  **Compute**.

RESULTS

Study 1/Solution 1 (sol1)

- 1 In the **Model Builder** window, expand the **Results > Datasets** node, then click **Study 1/Solution 1 (sol1)**.
- 2 In the **Settings** window for **Solution**, locate the **Solution** section.
- 3 From the **Frame** list, choose **Material (R, PHI, Z)**.

Magnetic Flux Density (mf)

- 1 In the **Model Builder** window, expand the **Results > Magnetic Flux Density (mf)** node, then click **Magnetic Flux Density (mf)**.
- 2 In the **Settings** window for **2D Plot Group**, locate the **Plot Settings** section.
- 3 From the **Frame** list, choose **Material (R, PHI, Z)**.



Streamline 1

In the **Model Builder** window, right-click **Streamline 1** and choose **Delete**.

Contour 1

Right-click **Contour 1** and choose **Delete**.

Magnetic Flux Density (mf)

- 1 In the **Model Builder** window, under **Results** click **Magnetic Flux Density (mf)**.
- 2 In the **Magnetic Flux Density (mf)** toolbar, click  **Plot**.
- 3 Click the  **Go to Default View** button in the **Graphics** toolbar.

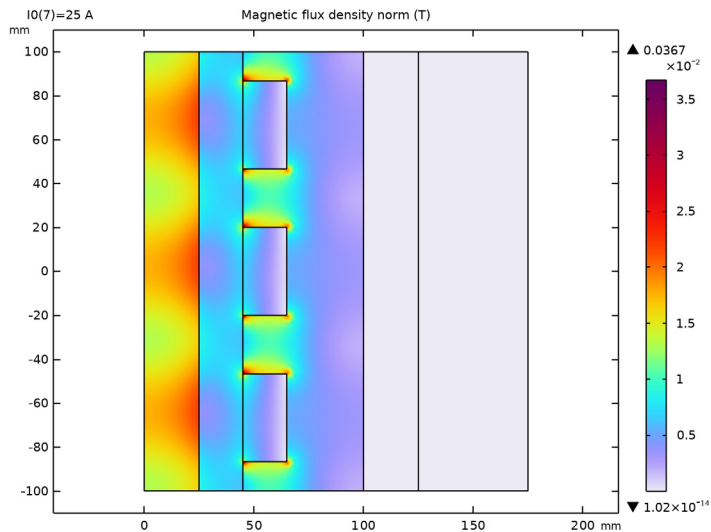



Magnetic Flux Density, Revolved Geometry (mf)

In the **Model Builder** window, right-click **Magnetic Flux Density, Revolved Geometry (mf)** and choose **Delete**.

Velocity (spf)

- 1 In the **Settings** window for **2D Plot Group**, locate the **Color Legend** section.

- 2 Select the **Show maximum and minimum values** checkbox.
- 3 In the **Velocity (spf)** toolbar, click  **Plot**.
- 4 Click the  **Go to Default View** button in the **Graphics** toolbar.

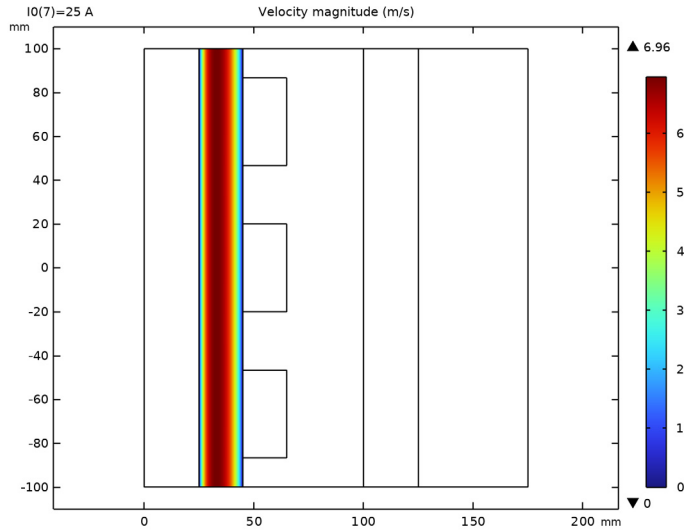

Pressure (spf)

- 1 In the **Model Builder** window, expand the **Velocity (spf)** node, then click **Results > Pressure (spf)**.
- 2 In the **Settings** window for **2D Plot Group**, locate the **Color Legend** section.
- 3 Select the **Show maximum and minimum values** checkbox.
- 4 In the **Pressure (spf)** toolbar, click  **Plot**.

5 Click the  **Go to Default View** button in the **Graphics** toolbar.

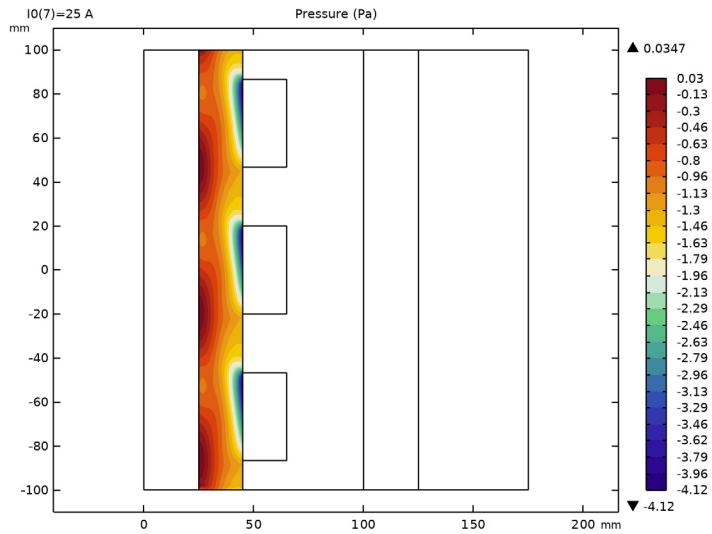

Velocity (spf) 1

- 1 In the **Model Builder** window, expand the **Pressure (spf)** node, then click **Results > Velocity, 3D (spf)**.
- 2 In the **Settings** window for **3D Plot Group**, type Velocity (spf) 1 in the **Label** text field.
- 3 Locate the **Color Legend** section. Select the **Show maximum and minimum values** checkbox.
- 4 In the **Velocity (spf) 1** toolbar, click  **Plot**.

- Click the  **Go to Default View** button in the **Graphics** toolbar.

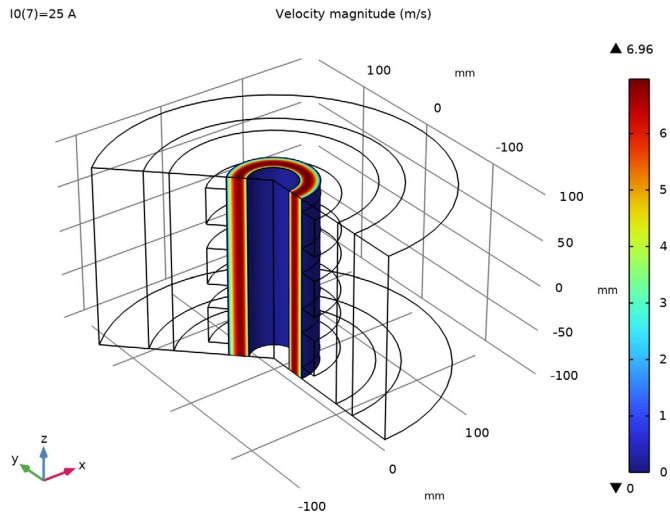

Velocity and Magnetic Flux Density

- In the **Model Builder** window, expand the **Velocity (spf) 1** node.
- Right-click **Results > Velocity (spf) 1** and choose **2D Plot Group**.
- In the **Settings** window for **2D Plot Group**, type Velocity and Magnetic Flux Density in the **Label** text field.
- Locate the **Plot Settings** section. Clear the **Plot dataset edges** checkbox.
- Locate the **Color Legend** section. Select the **Show maximum and minimum values** checkbox.
- Select the **Show units** checkbox.

Contour 1

- Right-click **Velocity and Magnetic Flux Density** and choose **Contour**.
- In the **Settings** window for **Contour**, locate the **Expression** section.
- In the **Expression** text field, type $r \cdot A \cdot \phi_i$.
- Locate the **Levels** section. Clear the **Round the levels** checkbox.
- Locate the **Coloring and Style** section. From the **Coloring** list, choose **Uniform**.
- From the **Color** list, choose **Black**.
- Clear the **Color legend** checkbox.

- 8 Click to expand the **Title** section. From the **Title type** list, choose **None**.

Arrow Surface 1

- 1 In the **Model Builder** window, right-click **Velocity and Magnetic Flux Density** and choose **Arrow Surface**.
- 2 In the **Settings** window for **Arrow Surface**, click to expand the **Title** section.
- 3 From the **Title type** list, choose **None**.
- 4 Click **Replace Expression** in the upper-right corner of the **Expression** section. From the menu, choose **Component 1 (comp1) > Laminar Flow > Velocity and pressure > u,w - Velocity field**.
- 5 Locate the **Arrow Positioning** section. Find the **R grid points** subsection. From the **Entry method** list, choose **Coordinates**.
- 6 In the **Coordinates** text field, type range (25.1, 18/10, 44).
- 7 Locate the **Coloring and Style** section. From the **Color** list, choose **Black**.

Surface 1

- 1 Right-click **Velocity and Magnetic Flux Density** and choose **Surface**.
- 2 In the **Settings** window for **Surface**, click to expand the **Title** section.
- 3 From the **Title type** list, choose **Custom**.
- 4 Find the **Type and data** subsection. Clear the **Type** checkbox.
- 5 Click **Replace Expression** in the upper-right corner of the **Expression** section. From the menu, choose **Component 1 (comp1) > Laminar Flow > Velocity and pressure > spf.U - Velocity magnitude - m/s**.
- 6 Locate the **Coloring and Style** section. From the **Color table** list, choose **Traffic**.
- 7 From the **Color table transformation** list, choose **Reverse**.

Surface 2

- 1 Right-click **Velocity and Magnetic Flux Density** and choose **Surface**.
- 2 In the **Settings** window for **Surface**, locate the **Title** section.
- 3 From the **Title type** list, choose **Custom**.
- 4 Find the **Type and data** subsection. Clear the **Type** checkbox.
- 5 Locate the **Coloring and Style** section. From the **Color table** list, choose **RainbowLight**.

Selection 1

- 1 Right-click **Surface 2** and choose **Selection**.
- 2 Select Domains 1, 3, and 7 only.



Surface 3

- 1 In the **Model Builder** window, right-click **Velocity and Magnetic Flux Density** and choose **Surface**.
- 2 In the **Settings** window for **Surface**, click **Replace Expression** in the upper-right corner of the **Expression** section. From the menu, choose **Component 1 (comp1) > Magnetic Fields > Currents and charge > Current density - A/m² > mf.Jphi - Current density, phi-component**.
- 3 Locate the **Title** section. From the **Title type** list, choose **Custom**.
- 4 Find the **Type and data** subsection. Clear the **Type** checkbox.
- 5 Locate the **Coloring and Style** section. From the **Color table** list, choose **Inferno**.

Selection 1

- 1 Right-click **Surface 3** and choose **Selection**.
- 2 Select Domains 4–6 only.

Velocity and Magnetic Flux Density

- 1 In the **Model Builder** window, under **Results** click **Velocity and Magnetic Flux Density**.
- 2 In the **Velocity and Magnetic Flux Density** toolbar, click  **Plot**.
- 3 Click the  **Go to Default View** button in the **Graphics** toolbar.

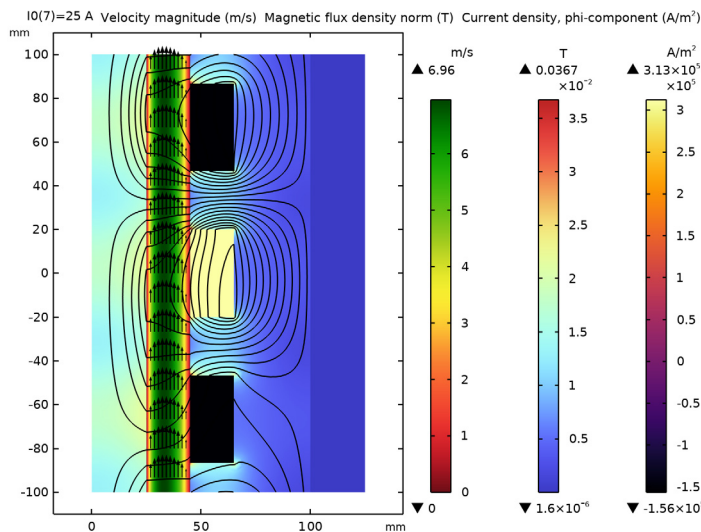

Lorentz Force and Current Density

- 1 In the **Home** toolbar, click  **Add Plot Group** and choose **2D Plot Group**.

- 2 In the **Settings** window for **2D Plot Group**, type Lorentz Force and Current Density in the **Label** text field.
- 3 Locate the **Color Legend** section. Select the **Show maximum and minimum values** checkbox.

Surface 1

- 1 Right-click **Lorentz Force and Current Density** and choose **Surface**.
- 2 In the **Settings** window for **Surface**, click **Replace Expression** in the upper-right corner of the **Expression** section. From the menu, choose **Component 1 (comp1) > Magnetic Fields > Currents and charge > Current density - A/m² > mf.Jphi - Current density, phi-component**.
- 3 Locate the **Coloring and Style** section. From the **Scale** list, choose **Linear symmetric**.
- 4 From the **Color table** list, choose **WaveLight**.

Contour 1



- 1 In the **Model Builder** window, right-click **Lorentz Force and Current Density** and choose **Contour**.
- 2 In the **Settings** window for **Contour**, locate the **Expression** section.
- 3 In the **Expression** text field, type $r \cdot A_{phi}$.
- 4 Locate the **Levels** section. Clear the **Round the levels** checkbox.
- 5 Locate the **Coloring and Style** section. From the **Coloring** list, choose **Uniform**.
- 6 From the **Color** list, choose **Black**.
- 7 Clear the **Color legend** checkbox.
- 8 Locate the **Title** section. From the **Title type** list, choose **None**.

Arrow Surface 1

- 1 Right-click **Lorentz Force and Current Density** and choose **Arrow Surface**.
- 2 In the **Settings** window for **Arrow Surface**, click **Replace Expression** in the upper-right corner of the **Expression** section. From the menu, choose **Component 1 (comp1) > Magnetic Fields > Mechanical > mf.FLTzavr,mf.FLTzavz - Lorentz force contribution, time average**.
- 3 Locate the **Arrow Positioning** section. Find the **R grid points** subsection. From the **Entry method** list, choose **Coordinates**.
- 4 In the **Coordinates** text field, type $\text{range}(25.1, 18/10, 44)$.
- 5 Find the **Z grid points** subsection. In the **Points** text field, type 30.
- 6 Locate the **Coloring and Style** section. From the **Arrow length** list, choose **Logarithmic**.

7 From the **Color** list, choose **Black**.

Lorentz Force and Current Density

- 1 Click the  **Zoom Extents** button in the **Graphics** toolbar.
- 2 In the **Model Builder** window, click **Lorentz Force and Current Density**.
- 3 In the **Lorentz Force and Current Density** toolbar, click  **Plot**.
- 4 Click the  **Go to Default View** button in the **Graphics** toolbar.

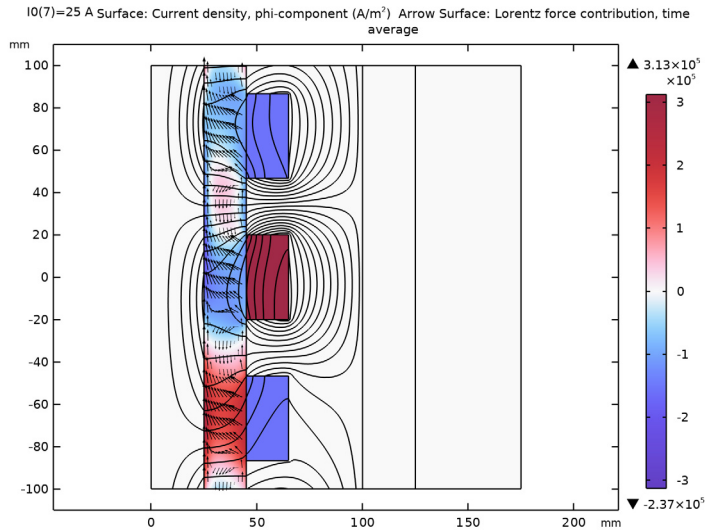

Velocity and Magnetic Flux Density, Revolved Geometry

- 1 In the **Results** toolbar, click  **3D Plot Group**.
- 2 In the **Settings** window for **3D Plot Group**, type **Velocity and Magnetic Flux Density, Revolved Geometry** in the **Label** text field.
- 3 Locate the **Plot Settings** section. Clear the **Plot dataset edges** checkbox.
- 4 Locate the **Color Legend** section. Select the **Show units** checkbox.

Volume 1

- 1 Right-click **Velocity and Magnetic Flux Density, Revolved Geometry** and choose **Volume**.
- 2 In the **Settings** window for **Volume**, locate the **Expression** section.
- 3 In the **Expression** text field, type $mf.normB / ((dom!=2) * (dom!=8) * (dom!=7))$.
- 4 Click to expand the **Title** section. From the **Title type** list, choose **Custom**.
- 5 Find the **Type and data** subsection. Clear the **Type** checkbox.

- 6 Locate the **Expression** section.
- 7 Select the **Description** checkbox. In the associated text field, type `Magnetic flux density`.
- 8 Locate the **Coloring and Style** section. From the **Color table** list, choose **AuroraBorealis**.

Volume 2

- 1 In the **Model Builder** window, right-click **Velocity and Magnetic Flux Density, Revolved Geometry** and choose **Volume**.
- 2 In the **Settings** window for **Volume**, locate the **Expression** section.
- 3 In the **Expression** text field, type `abs(spf.U)`.
- 4 Select the **Description** checkbox. In the associated text field, type `Fluid velocity`.
- 5 Locate the **Title** section. From the **Title type** list, choose **Custom**.
- 6 Find the **Type and data** subsection. Clear the **Type** checkbox.
- 7 Locate the **Coloring and Style** section. From the **Color table** list, choose **JupiterAuroraBorealis**.
- 8 From the **Color table transformation** list, choose **Reverse**.

Deformation 1

- 1 Right-click **Volume 2** and choose **Deformation**.
- 2 In the **Settings** window for **Deformation**, locate the **Expression** section.
- 3 In the **R-component** text field, type `0`.
- 4 In the **PHI-component** text field, type `0`.
- 5 In the **Z-component** text field, type `abs(w)`.
- 6 Locate the **Scale** section.
- 7 Select the **Scale factor** checkbox. In the associated text field, type `3`.

Contour 1

- 1 In the **Model Builder** window, right-click **Velocity and Magnetic Flux Density, Revolved Geometry** and choose **Contour**.
- 2 In the **Settings** window for **Contour**, locate the **Expression** section.
- 3 In the **Expression** text field, type `Aphi*r`.
- 4 Locate the **Levels** section. Clear the **Round the levels** checkbox.
- 5 Locate the **Coloring and Style** section. From the **Coloring** list, choose **Uniform**.
- 6 From the **Color** list, choose **Black**.
- 7 Clear the **Color legend** checkbox.

8 Click to expand the **Title** section. From the **Title type** list, choose **None**.

Velocity and Magnetic Flux Density, Revolved Geometry

1 In the **Model Builder** window, click **Velocity and Magnetic Flux Density, Revolved Geometry**.

2 In the **Velocity and Magnetic Flux Density, Revolved Geometry** toolbar, click  **Plot**.

3 Click the  **Go to Default View** button in the **Graphics** toolbar.

