



Model created in COMSOL Multiphysics 6.4

Magnetic Damping of Vibrating Conducting Solids

Introduction

When a conductive solid material moves through a static magnetic field, an eddy current density is induced. That induced eddy current density interacts with the static magnetic field, and the result is a Lorentz force acting on the solid that counteracts the motion. Therefore, a conducting solid that is oscillating in a static magnetic field experiences structural damping.

This example computes the damping effect in two different ways. First, by harmonically exciting a cantilever beam across a range of frequencies and placing it in a strong magnetic field. The same effect is then computed in a full transient study when the beam instead experiences a sudden applied load. The approach presented here assumes that the relative magnitudes of the structural displacements are small, that the material has isotropic and linear properties, and that the damping Lorentz force can be computed from the static magnetic field and the motion induced AC eddy current density. Second-order effects arising from the AC magnetic field generated by the eddy currents are not included in the computation. The AC magnetic field is also computed and found to be 2–3 orders of magnitude smaller than the DC magnetic field.

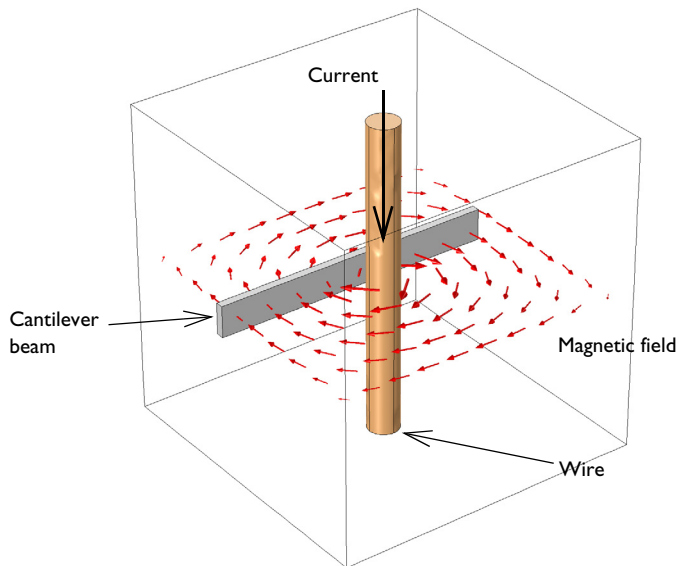

Figure 1: A vibrating beam next to a current-carrying wire experiences magnetic damping.

Model Definition

For a solid material experiencing a time-harmonic forced excitation, the displacement field is of the form

$$\mathbf{u}(\mathbf{r}, t) = \hat{\mathbf{u}}(\mathbf{r}) \sin(\omega t),$$

which can also be written in the frequency domain as a phasor:

$$\mathbf{u}(\mathbf{r}, t) = \text{Re}(\hat{\mathbf{u}}(\mathbf{r})e^{i\omega t})$$

Thus, the velocity field is given by

$$\mathbf{v}(\mathbf{r}, t) = \text{Re}(i\omega\hat{\mathbf{u}}(\mathbf{r})e^{i\omega t})$$

In the transient study, the displacement field is not necessarily an exact sine wave. However, as can be seen in [Figure 5](#), it behaves similarly. In that case, it is already slightly damped even without the addition of the magnetic field, as it approaches its equilibrium position.

Next, consider the effect of a spatially nonuniform, but static, magnetic flux density $\mathbf{B}_{\text{DC}}(\mathbf{r})$. Under the assumption that the local displacements are small enough for each moving point in the solid to only see the magnetic flux density in the undeformed state, the velocity induced current density is given by

$$\mathbf{J}_i = \sigma \mathbf{v} \times \mathbf{B}_{\text{DC}}(\mathbf{r})$$

where σ is the material conductivity. The resulting total AC current density is different, as the metallic cantilever beam is inductive and therefore exhibits a skin effect. Thus, a second, magnetodynamic, problem has to be solved in order to compute the AC current density. The body forces experienced by a current-carrying domain moving through a magnetic field are then given by the cross product between the induced AC current density and the static magnetic flux density:

$$\mathbf{F}_B = \mathbf{J}_{\text{AC}} \times \mathbf{B}_{\text{DC}}(\mathbf{r})$$

These body forces are then applied to the structural mechanics problem and act as a damping force on the system.

The application contains two different studies, both of which first compute the static magnetic field due to a current-carrying wire which is next to an aluminum beam. In the first case, the second step is set as a Frequency Domain Perturbation study. There, the beam experiences a forced harmonic vibration and the resulting mechanical beam

displacement field and AC current density are computed, yielding also the damping electromagnetic force. In the second case, the second step is instead set as a Time Dependent study, where the full transient solution is found. A constant boundary load is applied to the end of the beam instead of the harmonic perturbation in the previous case. However, since that load is applied suddenly at the start of the study instead of ramping up slowly, it will still cause the beam to oscillate.

In both cases, the strength of the magnetic field is then varied through a Parametric Sweep, and the effect of the magnetic damping on the response of the system can be observed and compared between the two approaches.

Results and Discussion

Figure 2 shows the magnetic flux density computed for the structure at rest. Figure 3 displays the magnitude of the displacement of the tip of the beam versus excitation frequency for two different magnetic field intensities for the frequency-domain structural dynamics problem. The magnetic field provides significant additional damping. Figure 4 shows a snapshot of the induced eddy current distribution in the beam. Figure 5 shows how the displacement of the tip of the beam varies with time in the full time dependent model. There, the effects of the magnetic damping become even more apparent. The amplitude of the oscillations decreases much quicker with time when a current passes through the wire, compared to the case where there is no current. It is also interesting to compare the results in that plot with the results in the corresponding plot from the frequency domain, shown in Figure 3.

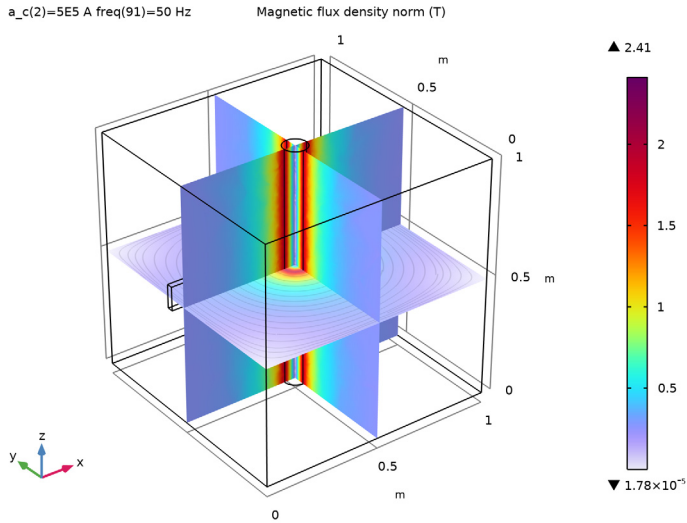

Figure 2: The magnetic field around a current-carrying wire.

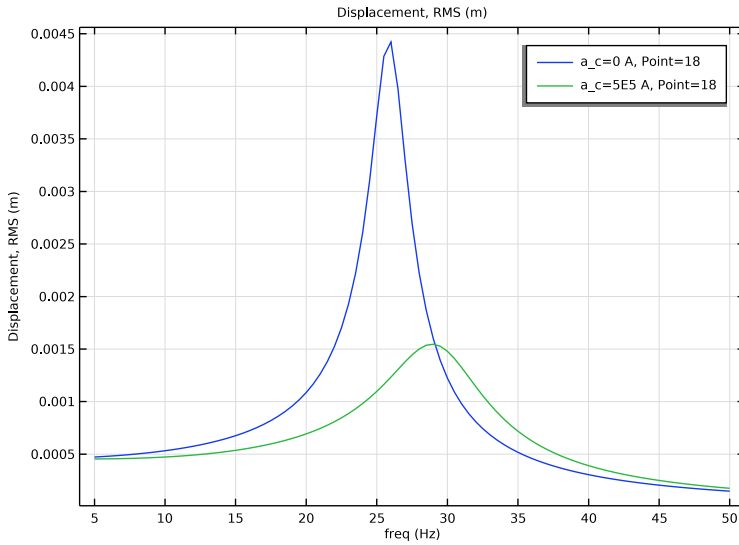

Figure 3: Displacement of the tip of the beam versus excitation frequency for differing values of the current through the wire.

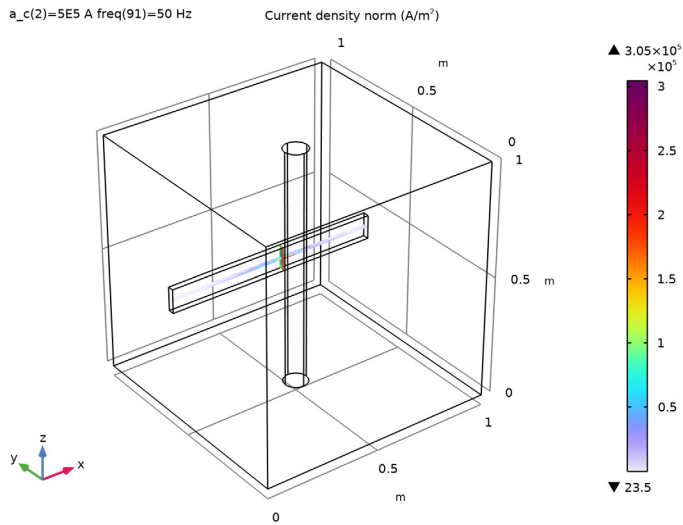

Figure 4: The AC current distribution.

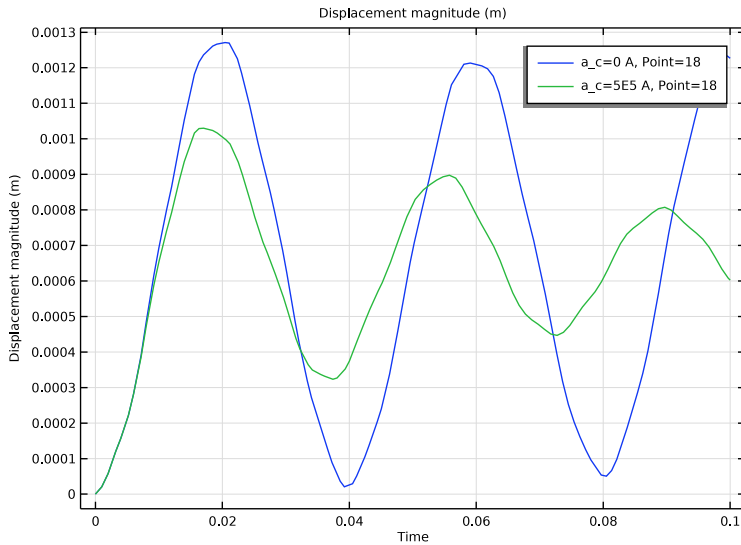

Figure 5: Displacement of the tip of the beam as a function of time, for different values of the current through the wire.

Notes About the COMSOL Implementation

Solve this application with two physics interfaces: the Magnetic Fields and Solid Mechanics interfaces. Use a Stationary study for the first Magnetic Fields interface and either a Frequency Domain Perturbation study or a Time Dependent study for the Magnetic Fields and Solid Mechanics interfaces. The coupling between the two interfaces is automatically considered by using the Magnetomechanics multiphysics coupling feature.

Application Library path: ACDC_Module/Electromagnetics_and_Mechanics/magnetic_damping



Modeling Instructions

From the **File** menu, choose **New**.

NEW

In the **New** window, click  **Model Wizard**.

MODEL WIZARD

- 1 In the **Model Wizard** window, click  **3D**.
- 2 In the **Select Physics** tree, select **AC/DC > Electromagnetic Fields > Magnetic Fields (mf)**.
- 3 Click **Add**.
- 4 In the **Select Physics** tree, select **Structural Mechanics > Solid Mechanics (solid)**.
- 5 Click **Add**.
- 6 Click  **Study**.
- 7 In the **Select Study** tree, select **Empty Study**.
- 8 Click  **Done**.

GLOBAL DEFINITIONS

Parameters I

- 1 In the **Model Builder** window, under **Global Definitions** click **Parameters I**.
- 2 In the **Settings** window for **Parameters**, locate the **Parameters** section.

3 In the table, enter the following settings:

Name	Expression	Value	Description
sigma	3.774e7[S/m]	3.774E7 S/m	Material conductivity
a_c	5e5[A]	5E5 A	Applied current on the wire
r0	0.05[m]	0.05 m	Radius of the coil

The Applied current will be used as a sweep parameter.

GEOMETRY I

- 1 In the **Model Builder** window, under **Component 1 (comp1)** click **Geometry 1**.
- 2 In the **Geometry** toolbar, click **Block** to create a block for the simulation domain. Leave the default block size.
- 3 In the **Geometry** toolbar, click **Block** again to create a block for the cantilever beam.

Cantilever Beam

- 1 In the **Model Builder** window, under **Component 1 (comp1)** > **Geometry 1** click **Block 2 (blk2)**.
- 2 In the **Settings** window for **Block**, type **Cantilever Beam** in the **Label** text field.
- 3 Locate the **Size and Shape** section. In the **Width** text field, type 0.9.
- 4 In the **Depth** text field, type 0.025.
- 5 In the **Height** text field, type 0.1.
- 6 Locate the **Position** section. In the **y** text field, type 0.575.
- 7 In the **z** text field, type 0.45.
- 8 Locate the **Selections of Resulting Entities** section. Select the **Resulting objects selection** checkbox.

Finally, add a cylinder for the wire generating the static magnetic field.

Cylindrical Coil

- 1 In the **Geometry** toolbar, click  **Cylinder**.
- 2 In the **Settings** window for **Cylinder**, type **Cylindrical Coil** in the **Label** text field.
- 3 Locate the **Size and Shape** section. In the **Radius** text field, type r0.
- 4 Locate the **Position** section. In the **x** text field, type 0.5.
- 5 In the **y** text field, type 0.5.
- 6 Locate the **Selections of Resulting Entities** section. Select the **Resulting objects selection** checkbox.

7 Click  **Build All Objects**.

8 Click the  **Wireframe Rendering** button in the **Graphics** toolbar.

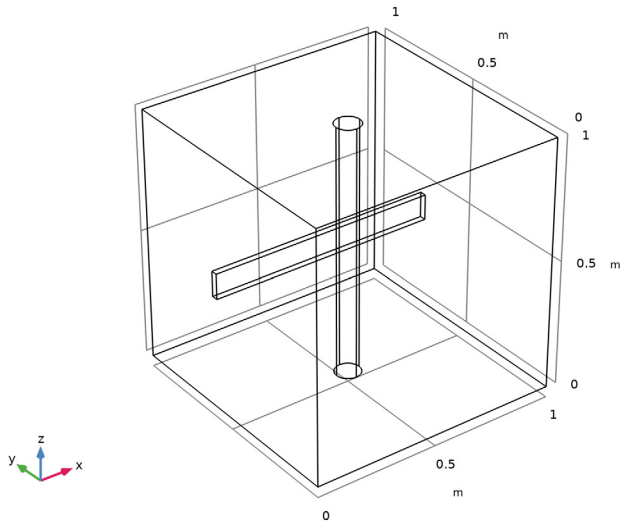

Add variables for the induced current density and body force on the cantilever beam.

MAGNETIC FIELDS (MF)

Ampère's Law in Solids I

- 1 In the **Physics** toolbar, click  **Domains** and choose **Ampère's Law in Solids**.
- 2 In the **Settings** window for **Ampère's Law in Solids**, locate the **Domain Selection** section.
- 3 From the **Selection** list, choose **Cantilever Beam**.

Domain Coil I

- 1 In the **Physics** toolbar, click  **Domains** and choose **Domain Coil**.
- 2 In the **Settings** window for **Domain Coil**, locate the **Domain Selection** section.

3 From the **Selection** list, choose **Cylindrical Coil**.

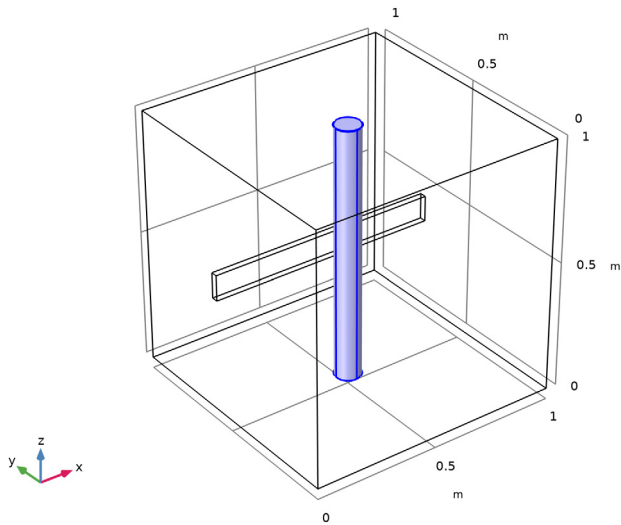

4 Locate the **Coil** section. From the **Conductor model** list, choose **Homogenized multiturn**.

5 From the **Coil type** list, choose **Linear**.

6 In the I_{coil} text field, type a_c .

7 Locate the **Homogenized Conductor** section. In the N text field, type 1.

8 From the **Coil wire cross-section area** list, choose **From diameter**.

9 In the d text field, type $2*r_0$.

Coil Geometry 1

1 In the **Model Builder** window, click **Coil Geometry 1**.

2 Select Edge 25 only.

Free Space 1

The **Free Space** feature adds a small electric conductivity to the surrounding volume for numerical stabilization.

1 In the **Model Builder** window, under **Component 1 (comp1) > Magnetic Fields (mf)** click **Free Space 1**.

2 In the **Settings** window for **Free Space**, locate the **Stabilization** section.

3 From the σ_{stab} list, choose **User defined**. In the associated text field, type $10[\text{S/m}]$.

SOLID MECHANICS (SOLID)

The **Solid Mechanics** interface is active only on the cantilever beam.

- 1 In the **Model Builder** window, under **Component 1 (comp1)** click **Solid Mechanics (solid)**.
- 2 In the **Settings** window for **Solid Mechanics**, locate the **Domain Selection** section.
- 3 From the **Selection** list, choose **Cantilever Beam**.

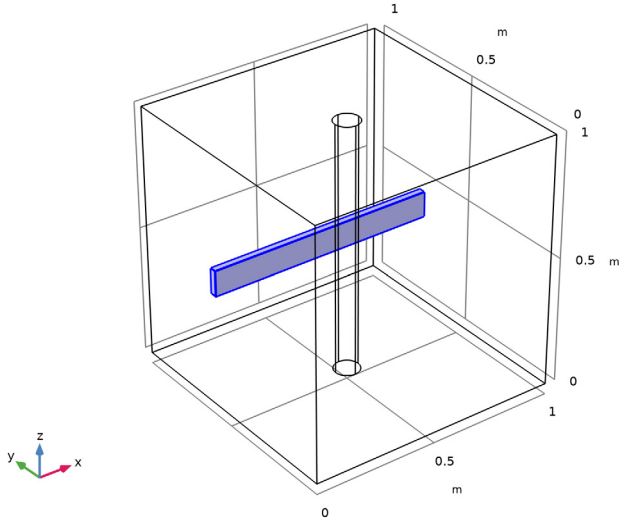

Linear Elastic Material 1

Add a damping factor on **Linear Elastic Material Model 1**.

- 1 In the **Model Builder** window, under **Component 1 (comp1)** > **Solid Mechanics (solid)** click **Linear Elastic Material 1**.

Damping 1

- 1 In the **Physics** toolbar, click  **Attributes** and choose **Damping**.
- 2 In the **Settings** window for **Damping**, locate the **Damping Settings** section.
- 3 From the **Damping type** list, choose **Isotropic loss factor**.
- 4 From the η_s list, choose **User defined**. In the associated text field, type 0.1.

Fixed Constraint 1

- 1 In the **Physics** toolbar, click  **Boundaries** and choose **Fixed Constraint**.

2 Select Boundary 5 only.

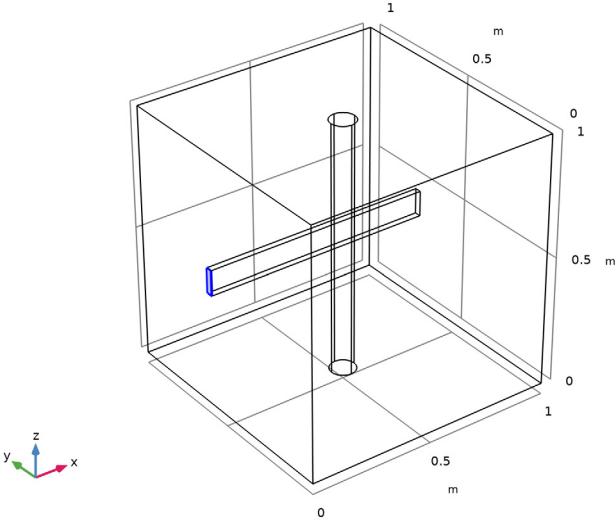

Harmonic Boundary Load for Frequency-Domain Vibration Analysis

1 In the **Physics** toolbar, click  **Boundaries** and choose **Boundary Load**.

2 Select Boundary 17 only.

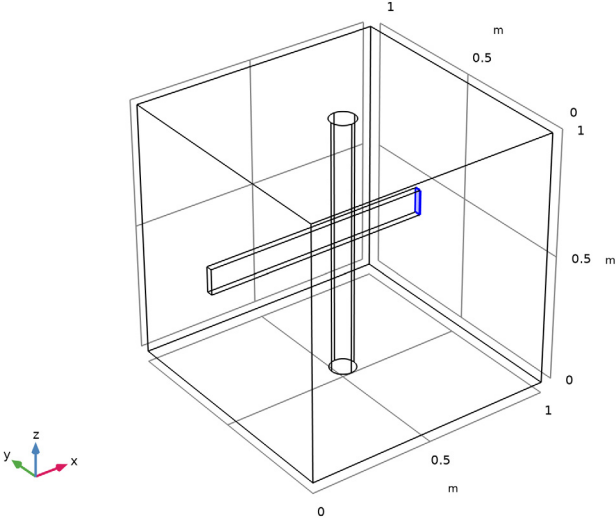

3 In the **Settings** window for **Boundary Load**, type Harmonic Boundary Load for Frequency-Domain Vibration Analysis in the **Label** text field.

4 Locate the **Force** section. Specify the \mathbf{f}_A vector as

0	x
1e4	y
0	z

5 Right-click **Harmonic Boundary Load for Frequency-Domain Vibration Analysis** and choose **Harmonic Perturbation**.

Boundary Load for Time-Dependent Analysis

1 In the **Physics** toolbar, click  **Boundaries** and choose **Boundary Load**.

2 Select Boundary 17 only.

3 In the **Settings** window for **Boundary Load**, type Boundary Load for Time-Dependent Analysis in the **Label** text field.

4 Locate the **Force** section. Specify the \mathbf{f}_A vector as

0	x
1e4	y
0	z

ADD MATERIAL

1 In the **Materials** toolbar, click  **Add Material** to open the **Add Material** window.

2 Go to the **Add Material** window.

3 In the tree, select **Built-in > Aluminum**.

4 Click the **Add to Component** button in the window toolbar.

5 In the **Materials** toolbar, click  **Add Material** to close the **Add Material** window.

MATERIALS

Aluminum (mat1)

1 In the **Settings** window for **Material**, locate the **Geometric Entity Selection** section.

- 2 From the **Selection** list, choose **Cantilever Beam**.

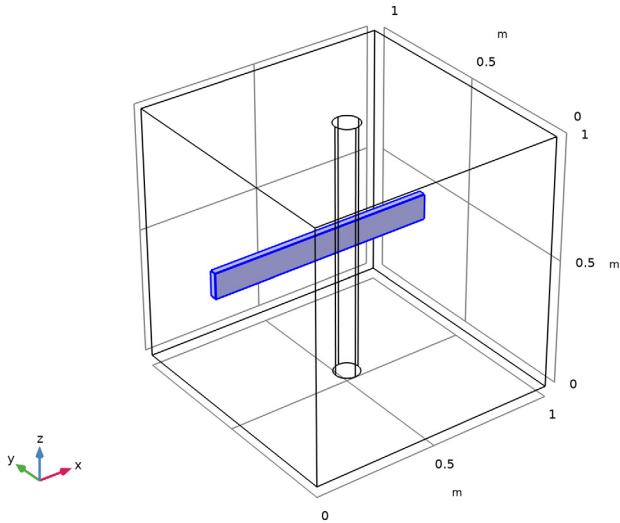

MULTIPHYSICS

Magnetomechanics, Solid 1 (mmcp11)

- 1 In the **Physics** toolbar, click  **Multiphysics Couplings** and choose **Domain** > **Magnetomechanics, Solid**.
- 2 In the **Settings** window for **Magnetomechanics, Solid**, locate the **Lorentz Coupling** section.
- 3 Select the **Only use Lorentz force** checkbox.

MESH 1

- 1 In the **Model Builder** window, under **Component 1 (comp1)** click **Mesh 1**.
- 2 In the **Settings** window for **Mesh**, locate the **Physics-Controlled Mesh** section.
- 3 From the **Element size** list, choose **Coarser**.

FREQUENCY-DOMAIN VIBRATION ANALYSIS

- 1 In the **Model Builder** window, click **Study 1**.
- 2 In the **Settings** window for **Study**, type Frequency-Domain Vibration Analysis in the **Label** text field.

Parametric Sweep

- 1 In the **Study** toolbar, click  **Parametric Sweep**.

- 2 In the **Settings** window for **Parametric Sweep**, locate the **Study Settings** section.
- 3 Click  **Add**.
- 4 In the table, enter the following settings:

Parameter name	Parameter value list	Parameter unit
a_c (Applied current on the wire)	0[A] 500000[A]	A

Step 1: Stationary

- 1 In the **Study** toolbar, click  **Stationary**.
- 2 In the **Settings** window for **Stationary**, locate the **Physics and Variables Selection** section.
- 3 In the **Solve for** column of the table, under **Component 1 (comp1)**, clear the checkbox for **Solid Mechanics (solid)**.
- 4 In the **Solve for** column of the table, under **Component 1 (comp1) > Multiphysics**, clear the checkbox for **Magnetomechanics, Solid 1 (mmcp1)**.

Step 2: Frequency-Domain Perturbation

- 1 In the **Study** toolbar, click  **More Study Steps** and choose **Frequency Domain > Frequency-Domain Perturbation**.
- 2 In the **Settings** window for **Frequency-Domain Perturbation**, locate the **Study Settings** section.
- 3 In the **Frequencies** text field, type range (5,0.5,50).
- 4 Locate the **Physics and Variables Selection** section. Select the **Modify model configuration for study step** checkbox.
- 5 In the tree, select **Component 1 (comp1) > Solid Mechanics (solid) > Boundary Load for Time-Dependent Analysis**.
- 6 Right-click and choose **Disable**.

Solution 1 (sol1)

- 1 In the **Study** toolbar, click  **Show Default Solver**.
Some adjustments to the default solver settings will improve the performance.
- 2 In the **Model Builder** window, expand the **Solution 1 (sol1)** node.
- 3 In the **Model Builder** window, expand the **Frequency-Domain Vibration Analysis > Solver Configurations > Solution 1 (sol1) > Stationary Solver 2** node, then click **Fully Coupled 1**.
- 4 In the **Settings** window for **Fully Coupled**, locate the **General** section.

5 From the **Linear solver** list, choose **Direct**.

6 In the **Study** toolbar, click  **Compute**.

RESULTS

DC Magnetic Flux Density Norm

The first default plot group shows the magnetic field around a current carrying wire; compare with [Figure 2](#). Give it a more descriptive name.

1 In the **Settings** window for **3D Plot Group**, type DC Magnetic Flux Density Norm in the **Label** text field.

Multislice 1

1 In the **Model Builder** window, expand the **DC Magnetic Flux Density Norm** node, then click **Multislice 1**.

2 In the **Settings** window for **Multislice**, locate the **Expression** section.

3 From the **Expression evaluated for** list, choose **Static solution**.

Streamline Multislice 1

1 In the **Model Builder** window, click **Streamline Multislice 1**.

2 In the **Settings** window for **Streamline Multislice**, locate the **Expression** section.

3 From the **Expression evaluated for** list, choose **Static solution**.

DC Magnetic Flux Density Norm

1 In the **Model Builder** window, click **DC Magnetic Flux Density Norm**.

2 In the **DC Magnetic Flux Density Norm** toolbar, click  **Plot**.

3 Click the  **Go to Default View** button in the **Graphics** toolbar.

AC Magnetic Flux Density Norm

1 Right-click **DC Magnetic Flux Density Norm** and choose **Duplicate**.

2 Drag and drop **DC Magnetic Flux Density Norm 1** below **DC Magnetic Flux Density Norm**.

The second plot group will show the AC magnetic flux density. Improve it by plotting the data in the cantilever beam only.

3 In the **Settings** window for **3D Plot Group**, type AC Magnetic Flux Density Norm in the **Label** text field.

Multislice 1

1 In the **Model Builder** window, expand the **AC Magnetic Flux Density Norm** node, then click **Multislice 1**.

- 2 In the **Settings** window for **Multislice**, locate the **Expression** section.
- 3 From the **Expression evaluated for list**, choose **Harmonic perturbation**.

Selection 1

- 1 Right-click **Multislice 1** and choose **Selection**.
- 2 Select Domain 2 only.

Streamline Multislice 1

- 1 In the **Model Builder** window, under **Results** > **AC Magnetic Flux Density Norm** click **Streamline Multislice 1**.
- 2 In the **Settings** window for **Streamline Multislice**, locate the **Expression** section.
- 3 From the **Expression evaluated for list**, choose **Harmonic perturbation**.

Selection 1

- 1 Right-click **Streamline Multislice 1** and choose **Selection**.
- 2 Select Domain 2 only.

AC Magnetic Flux Density Norm

- 1 In the **Model Builder** window, under **Results** click **AC Magnetic Flux Density Norm**.
- 2 In the **AC Magnetic Flux Density Norm** toolbar, click  **Plot**.

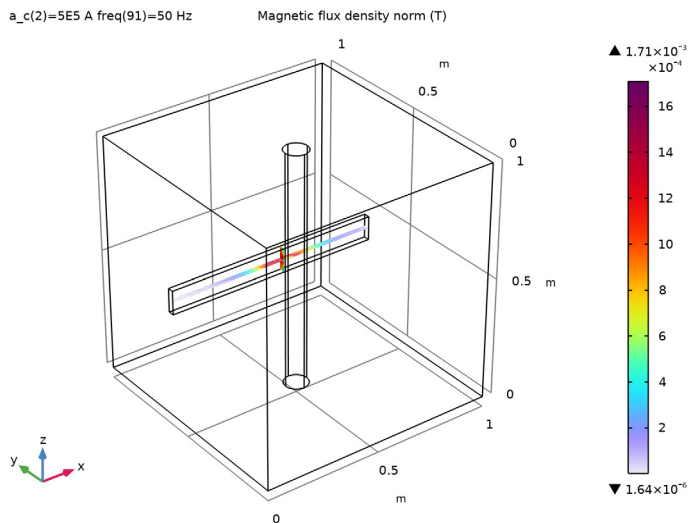

The plot now shows the magnitude of the AC magnetic flux density in the beam only.

Volume 1

- 1 In the **Model Builder** window, expand the **Results > Stress (solid)** node, then click **Volume 1**.
- 2 In the **Settings** window for **Volume**, locate the **Expression** section.
- 3 Clear the **Compute differential** checkbox.
- 4 In the **Stress (solid)** toolbar, click  **Plot**.

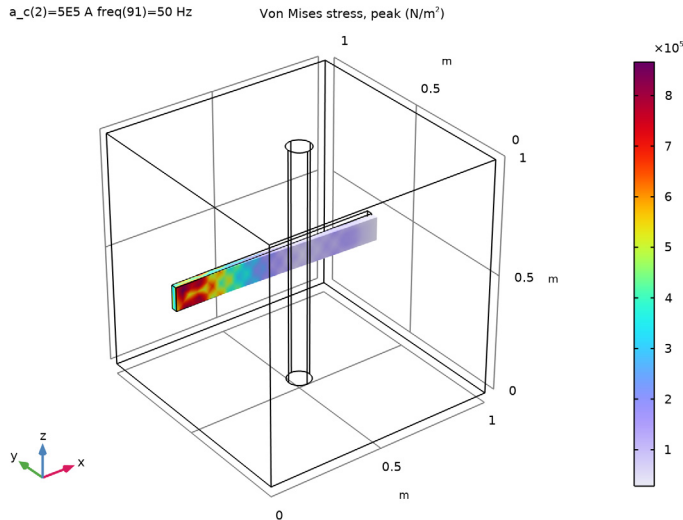

This plot shows the peak von Mises stress in the beam.

Next, add a plot for the AC currents in the beam.

AC Electric Current Density

- 1 In the **Model Builder** window, right-click **AC Magnetic Flux Density Norm** and choose **Duplicate**.
- 2 In the **Settings** window for **3D Plot Group**, type AC Electric Current Density in the **Label** text field.

Multislice 1

- 1 In the **Model Builder** window, expand the **AC Electric Current Density** node, then click **Multislice 1**.
- 2 In the **Settings** window for **Multislice**, click **Replace Expression** in the upper-right corner of the **Expression** section. From the menu, choose **Component 1 (comp1) > Magnetic Fields > Currents and charge > mf.normj - Current density norm - A/m²**.

Streamline Multislice 1

- 1 In the **Model Builder** window, click **Streamline Multislice 1**.
- 2 In the **Settings** window for **Streamline Multislice**, click **Replace Expression** in the upper-right corner of the **Expression** section. From the menu, choose **Component 1 (comp1) > Magnetic Fields > Currents and charge > mf.jx,...,mf.jz - Current density (spatial frame)**.
- 3 In the **AC Electric Current Density** toolbar, click  **Plot**.

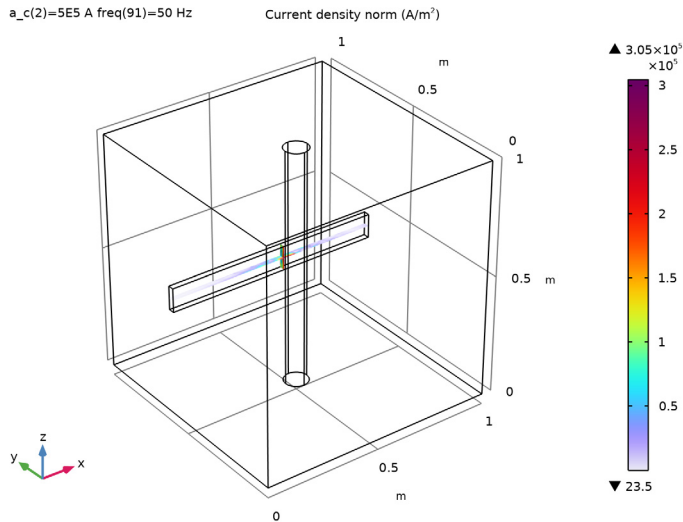

The AC eddy currents circulate within the beam.

Finish by plotting the RMS displacement of the tip of the beam as a function of frequency (Figure 3).

RMS Displacement vs. Frequency

- 1 In the **Results** toolbar, click  **ID Plot Group**.
- 2 In the **Settings** window for **ID Plot Group**, type RMS Displacement vs. Frequency in the **Label** text field.
- 3 Locate the **Data** section. From the **Dataset** list, choose **Frequency-Domain Vibration Analysis/Parametric Solutions 1 (sol3)**.



Point Graph 1

- 1 Right-click **RMS Displacement vs. Frequency** and choose **Point Graph**.
- 2 Select Point 18 only.

- 3 In the **Settings** window for **Point Graph**, click **Replace Expression** in the upper-right corner of the **y-Axis Data** section. From the menu, choose **Component 1 (comp1) > Solid Mechanics > Displacement > solid.disp_rms - Displacement, RMS - m**.
- 4 Click to expand the **Legends** section. Select the **Show legends** checkbox.
- 5 In the **RMS Displacement vs. Frequency** toolbar, click  **Plot**.
Compare the resulting plot with that shown in [Figure 3](#).

Now add a transient study to the model for comparison.

ADD STUDY

- 1 In the **Home** toolbar, click  **Add Study** to open the **Add Study** window.
- 2 Go to the **Add Study** window.
- 3 Find the **Studies** subsection. In the **Select Study** tree, select **General Studies > Stationary**.
- 4 Click the **Add Study** button in the window toolbar.
- 5 In the **Home** toolbar, click  **Add Study** to close the **Add Study** window.

TIME-DEPENDENT ANALYSIS

In the **Settings** window for **Study**, type Time-Dependent Analysis in the **Label** text field.

Parametric Sweep

- 1 In the **Study** toolbar, click  **Parametric Sweep**.
- 2 In the **Settings** window for **Parametric Sweep**, locate the **Study Settings** section.
- 3 Click **+ Add**.
- 4 In the table, enter the following settings:

Parameter name	Parameter value list	Parameter unit
a_c (Applied current on the wire)	0[A] 500000[A]	A

Step 1: Stationary

- 1 In the **Model Builder** window, click **Step 1: Stationary**.
- 2 In the **Settings** window for **Stationary**, locate the **Physics and Variables Selection** section.
- 3 In the **Solve for** column of the table, under **Component 1 (comp1)**, clear the checkbox for **Solid Mechanics (solid)**.
- 4 In the **Solve for** column of the table, under **Component 1 (comp1) > Multiphysics**, clear the checkbox for **Magnetomechanics, Solid 1 (mmcp1)**.



Step 2: Time Dependent

- 1 In the **Study** toolbar, click  **Time Dependent**.
- 2 In the **Settings** window for **Time Dependent**, locate the **Study Settings** section.
- 3 In the **Output times** text field, type range (0,0.001,0.1).
- 4 Locate the **Physics and Variables Selection** section. Select the **Modify model configuration for study step** checkbox.
- 5 In the tree, select **Component 1 (comp1) > Solid Mechanics (solid) > Harmonic Boundary Load for Frequency-Domain Vibration Analysis**.
- 6 Right-click and choose **Disable**.

To significantly reduce the computation time, it is also possible to tweak tolerances and solve the magnetic fields problem with a direct solver, since the air domain has a finite conductivity and the induced current acts as a gauge.

- 7 Locate the **Study Settings** section. From the **Tolerance** list, choose **User controlled**.

Solution 6 (sol6)

- 1 In the **Study** toolbar, click  **Show Default Solver**.
- 2 In the **Model Builder** window, expand the **Solution 6 (sol6)** node.
- 3 In the **Model Builder** window, expand the **Time-Dependent Analysis > Solver Configurations > Solution 6 (sol6) > Dependent Variables 2** node, then click **Magnetic Vector Potential (Spatial Frame) (comp1.A)**.
- 4 In the **Settings** window for **Field**, locate the **Scaling** section.
- 5 From the **Method** list, choose **None**.
- 6 In the **Model Builder** window, under **Time-Dependent Analysis > Solver Configurations > Solution 6 (sol6) > Dependent Variables 2** click **Filtering Variable (comp1.mf.coil1.Vf)**.
- 7 In the **Settings** window for **Field**, locate the **Scaling** section.
- 8 From the **Method** list, choose **None**.
- 9 In the **Study** toolbar, click  **Compute**.

RESULTS

Magnetic Flux Density (mf)

- 1 In the **Magnetic Flux Density (mf)** toolbar, click  **Plot**.

The first default plot from the second study again shows the static magnetic field around a current carrying wire; compare with [Figure 2](#).

The next plot shows the von Mises stress in the beam at the end of the transient study.

Stress (solid) I

- 1 In the **Model Builder** window, click **Stress (solid) I**.
- 2 In the **Stress (solid) I** toolbar, click  **Plot**.

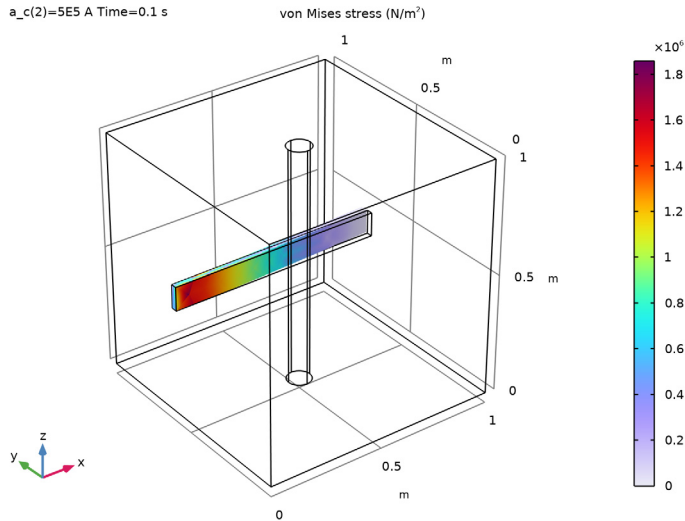

Finish by the displacement of the tip of the beam as a function of time (Figure 5).

Displacement vs. Time

- 1 In the **Results** toolbar, click  **ID Plot Group**.
- 2 In the **Settings** window for **ID Plot Group**, type Displacement vs. Time in the **Label** text field.
- 3 Locate the **Data** section. From the **Dataset** list, choose **Time-Dependent Analysis/ Parametric Solutions 2 (sol8)**.

Point Graph I

- 1 Right-click **Displacement vs. Time** and choose **Point Graph**.
- 2 Select Point 18 only.
- 3 In the **Settings** window for **Point Graph**, locate the **y-Axis Data** section.
- 4 In the **Expression** text field, type `solid.disp`.
- 5 Locate the **Legends** section. Select the **Show legends** checkbox.
- 6 In the **Displacement vs. Time** toolbar, click  **Plot**.