



Model created in COMSOL Multiphysics 6.4

Induction Heating Including Curie Temperature and Movement

Introduction

Induction heating is used for various metallurgical processes such as hardening. Here, the 3D induction heating of a mechanical joint passing through an induction heating coil is simulated. Curie point effects and temperature-dependent resistivity in the iron are taken into account.

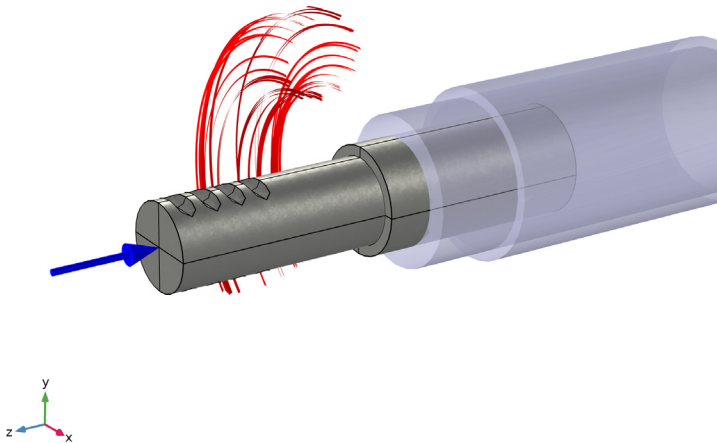

Figure 1: External current density (red streamlines) and prescribed velocity of the mechanical joint (blue arrow). The joint is surrounded by air, separated into one moving part (inner) and one stationary part (outer).

Model Definition

The problem is set up in a 3D modeling space and the geometry sequence is imported from a reference file. The model consists of a mechanical joint moving through a current-conducting coil as viewed in [Figure 1](#) using the Prescribed Deformation interface. The magnetic field is solved for in the entire model using the Magnetic Fields interface and the temperature in the joint is found using Heat Transfer in Solids. The temperature and magnetic field are coupled using Electromagnetic Heating. Symmetries are utilized to only model a quarter of the mechanical joint and its surroundings. Two studies are performed: the first solves for the magnetic field in the frequency domain, while the second solves the full transient model over one minute, using the first solution as the initial magnetic field.

The model takes the temperature-dependent resistivity into consideration. Curie point effects are also included, the temperature above which the magnetic properties of a material are lost.

A NOTE ON THE USE OF MAGNETIC CONTINUITY IN 3D

The geometry in this model uses an assembly, rather than a union. This is to accommodate for the moving domains (the mechanical joint) and the stationary domains (the coil). The assembly consists of two parts with disjoint meshes. A Moving Mesh is used to apply the motion. Since the two parts are not naturally connected, a continuity constraint will need to be added for the magnetic fields. To achieve this, the Magnetic Fields interface uses the **Magnetic Continuity** feature.

The Magnetic Fields interface uses curl elements to solve for the magnetic vector potential in 3D. As a consequence, enforcing the continuity directly between the two sliding meshes ($\mathbf{A}_{\text{dst}} = \mathbf{A}_{\text{src}}$ pointwise) will not guarantee current conservation. Unless when handled correctly (using conforming meshes and specific time steps) Ampère's Law may be violated. To allow for a nonconforming sliding mesh, an auxiliary scalar potential is introduced on the connecting boundary. It enforces the conditions:

$$\begin{aligned} \mathbf{n}_{\text{src}} \times \mathbf{H}_{\text{src}} &= \mathbf{n}_{\text{dst}} \times \mathbf{H}_{\text{dst}} \\ -\mathbf{n}_{\text{src}} \cdot (\mathbf{B}_{\text{src}} - \mathbf{B}_{\text{dst}}) &\approx 0, \end{aligned} \tag{1}$$

where the second equation is imposed via a suitable stabilization algorithm that shares the same topological properties as using the *Magnetic Fields, No Currents* magnetic scalar potential.

Results and Discussion

The frequency-domain solution for the magnetic flux density norm and generated heat in the mechanical joint is shown in [Figure 2](#). The heat is concentrated to the part of the joint directly underneath the external current. Skin effects are visible for the magnetic flux density.

For the transient study, the temperature evolution of a selection of points is shown in [Figure 3](#), the corresponding points are displayed in [Figure 4](#). The temperature and magnetic flux density after 30 seconds is shown in [Figure 5](#). Here, the displacement of the mechanical joint is also clear. A cross section of the temperature distribution at the final

time point is shown in [Figure 6](#) together with the maximum reached temperature at each point of the same cross section.

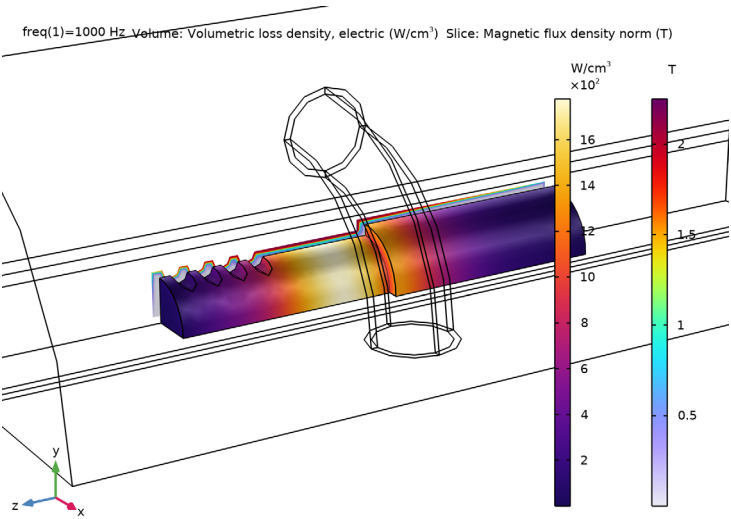

Figure 2: The stationary electromagnetic heat and magnetic flux density norm on the 2D slice.

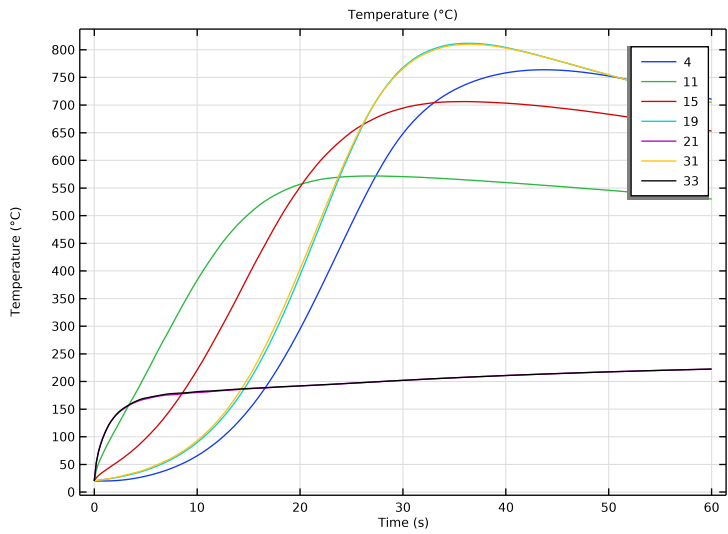

Figure 3: Temperature evolution of some selected points on the moving joint. The selected points are shown in Figure 4. The edge points 4, 19, and 31 reach the highest temperatures.

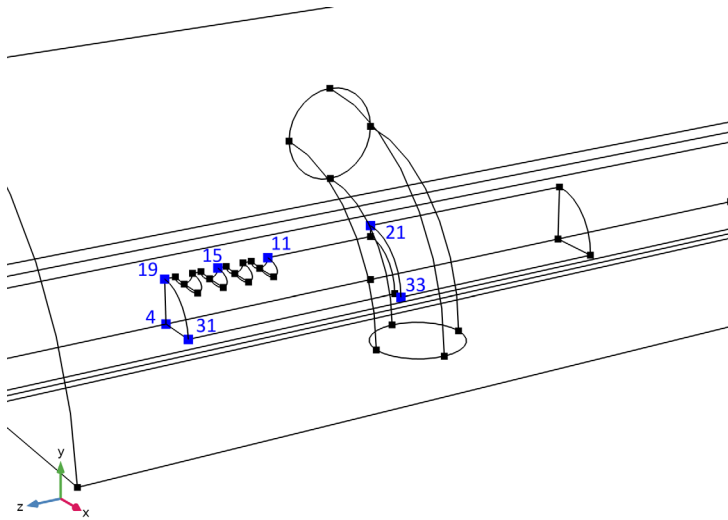

Figure 4: The selected points for the temperature evolution in Figure 3.

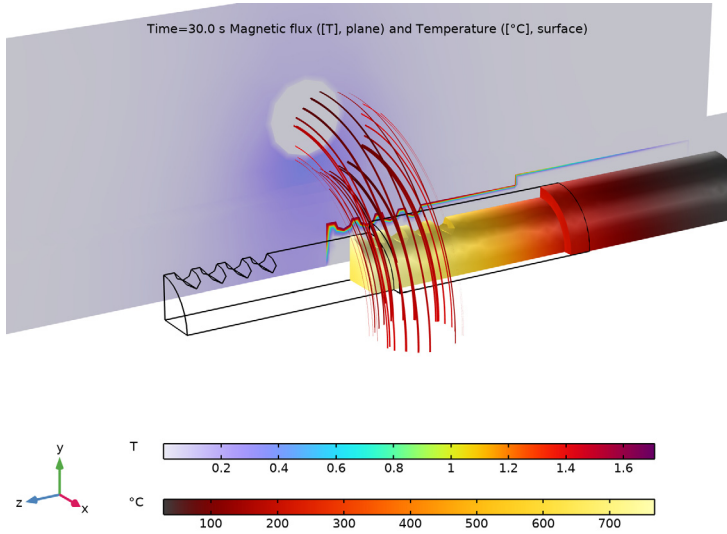

Figure 5: Temperature distribution of the joint, external current density (arrows), and magnetic flux density norm (slice) at $t = 30$ s.

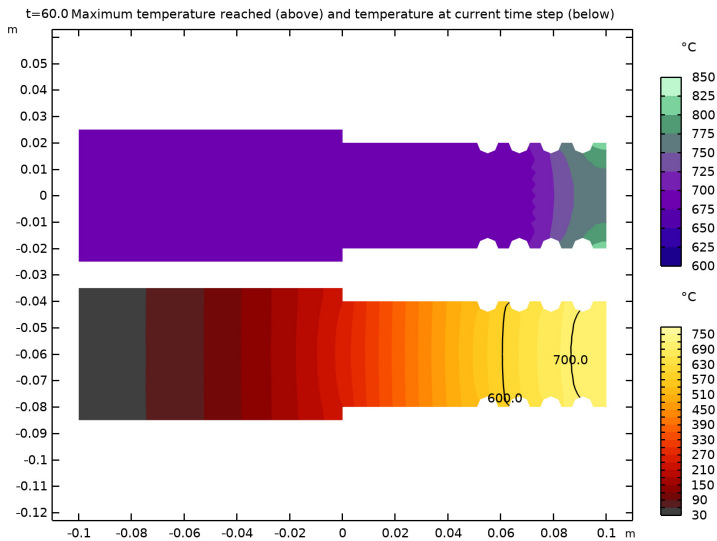

Figure 6: Cross section of the maximum reached temperature at each point in the joint and the temperature at $t = 60$ s in the transient study.

Application Library path: ACDC_Module/Electromagnetic_Heating/
induction_heating_curie_movement



Modeling Instructions

From the **File** menu, choose **New**.

NEW

In the **New** window, click  **Model Wizard**.

MODEL WIZARD



- 1 In the **Model Wizard** window, click .
- 2 In the **Select Physics** tree, select **AC/DC** > **Electromagnetic Fields** > **Magnetic Fields (mf)**.
- 3 Click **Add**.
- 4 In the **Select Physics** tree, select **Heat Transfer** > **Heat Transfer in Solids (ht)**.
- 5 Click **Add**.
- 6 In the **Select Physics** tree, select **Mathematics** > **Deformed Mesh** > **Moving Mesh** > **Prescribed Deformation**.
- 7 Click **Add**.
- 8 Click  **Study**.
- 9 In the **Select Study** tree, select **Preset Studies for Some Physics Interfaces** > **Frequency Domain**.
- 10 Click  **Done**.

GLOBAL DEFINITIONS

Parameters I

- 1 In the **Model Builder** window, under **Global Definitions** click **Parameters I**.
- 2 In the **Settings** window for **Parameters**, locate the **Parameters** section.
- 3 Click  **Load from File**.
- 4 Browse to the model's Application Libraries folder and double-click the file `induction_heating_curie_movement_parameters.txt`.

Interpolation 1 (int1)

- 1 In the **Home** toolbar, click  **Functions** and choose **Global > Interpolation**.
- 2 In the **Settings** window for **Interpolation**, locate the **Definition** section.
- 3 In the **Function name** text field, type murOfB.
- 4 Click  **Load from File**.
- 5 Browse to the model's Application Libraries folder and double-click the file induction_heating_curie_movement_mur_of_B.txt.
- 6 Locate the **Units** section. In the **Function** table, enter the following settings:

Function	Unit
murOfB	1

- 7 In the **Argument** table, enter the following settings:

Argument	Unit
t	T

Step 1 (step1)

- 1 In the **Home** toolbar, click  **Functions** and choose **Global > Step**.
- 2 In the **Settings** window for **Step**, type CuriePermFact in the **Function name** text field.
- 3 Locate the **Parameters** section. In the **Location** text field, type $273.15 + (Tc - 273.15) / 2$.
- 4 In the **From** text field, type 1.
- 5 In the **To** text field, type 0.
- 6 Click to expand the **Smoothing** section. In the **Size of transition zone** text field, type $(Tc - 273.15)$.
- 7 From the **Number of continuous derivatives** list, choose **1**.

Step 2 (CuriePermFact2)

- 1 Right-click **Step 1 (CuriePermFact)** and choose **Duplicate**.
- 2 In the **Settings** window for **Step**, type Conductivity in the **Function name** text field.
- 3 Locate the **Parameters** section. In the **From** text field, type $6e6$.
- 4 In the **To** text field, type $1e6$.

Gaussian Pulse 1 (gp1)

- 1 In the **Home** toolbar, click  **Functions** and choose **Global > Gaussian Pulse**.
- 2 In the **Settings** window for **Gaussian Pulse**, type CurieHeatFact in the **Function name** text field.

- 3 Locate the **Parameters** section. In the **Location** text field, type Tc.
- 4 In the **Standard deviation** text field, type 100.
- 5 In the **Integral value** text field, type 1[K].

GEOMETRY I

With the global definitions in order, construct the geometry. The geometry will utilize symmetries and consist of only a quarter of the full joint with its surroundings.

Work Plane 1 (wp1)

- 1 In the **Model Builder** window, expand the **Component 1 (comp1) > Geometry 1** node.
- 2 Right-click **Geometry 1** and choose **Work Plane**.
- 3 In the **Settings** window for **Work Plane**, locate the **Plane Definition** section.
- 4 From the **Plane** list, choose **zx-plane**.

Work Plane 1 (wp1) > Plane Geometry

In the **Model Builder** window, click **Plane Geometry**.

Work Plane 1 (wp1) > Rectangle 1 (r1)

- 1 In the **Work Plane** toolbar, click  **Rectangle**.
- 2 In the **Settings** window for **Rectangle**, locate the **Size and Shape** section.
- 3 In the **Width** text field, type 0.4.
- 4 In the **Height** text field, type 0.09.
- 5 Locate the **Position** section. In the **xw** text field, type -0.2.
- 6 In the **yw** text field, type 0.035.
- 7 Click to expand the **Layers** section. In the table, enter the following settings:

Layer name	Thickness (m)
Layer 1	0.005

Work Plane 1 (wp1) > Circle 1 (c1)

- 1 In the **Work Plane** toolbar, click  **Circle**.
- 2 In the **Settings** window for **Circle**, locate the **Size and Shape** section.
- 3 In the **Radius** text field, type 0.02.
- 4 Locate the **Position** section. In the **xw** text field, type 0.02.
- 5 In the **yw** text field, type 0.07.

6 Click to expand the **Layers** section. In the table, enter the following settings:

Layer name	Thickness (m)
Layer 1	0.003

Revolve 1 (rev1)

- 1 In the **Model Builder** window, right-click **Geometry 1** and choose **Revolve**.
- 2 In the **Settings** window for **Revolve**, locate the **Revolution Angles** section.
- 3 Click the **Angles** button.
- 4 In the **End angle** text field, type 90.
- 5 Locate the **Revolution Axis** section. Find the **Direction of revolution axis** subsection. In the **xw** text field, type 1.
- 6 In the **yw** text field, type 0.

All stationary domains have now been constructed. Now, to the moving domains.

Work Plane 2 (wp2)

- 1 In the **Geometry** toolbar, click  **Work Plane**.
- 2 In the **Settings** window for **Work Plane**, locate the **Plane Definition** section.
- 3 From the **Plane** list, choose **zx-plane**.
- 4 Locate the **Unite Objects** section. Clear the **Unite objects** checkbox.

Work Plane 2 (wp2) > Plane Geometry

In the **Model Builder** window, click **Plane Geometry**.

Work Plane 2 (wp2) > Rectangle 1 (r1)

- 1 In the **Work Plane** toolbar, click  **Rectangle**.
- 2 In the **Settings** window for **Rectangle**, locate the **Size and Shape** section.
- 3 In the **Width** text field, type 0.7.
- 4 In the **Height** text field, type 0.035.
- 5 Locate the **Position** section. In the **xw** text field, type -0.2.
- 6 Locate the **Layers** section. In the table, enter the following settings:

Layer name	Thickness (m)
Layer 1	0.005

- 7 Clear the **Layers on bottom** checkbox.
- 8 Select the **Layers on top** checkbox.

Work Plane 2 (wp2) > Rectangle 2 (r2)

- 1 In the **Work Plane** toolbar, click  **Rectangle**.
- 2 In the **Settings** window for **Rectangle**, locate the **Size and Shape** section.
- 3 In the **Width** text field, type 0.1.
- 4 In the **Height** text field, type 0.025.
- 5 Locate the **Position** section. In the **xw** text field, type -0.1.

Work Plane 2 (wp2) > Rectangle 3 (r3)

- 1 In the **Work Plane** toolbar, click  **Rectangle**.
- 2 In the **Settings** window for **Rectangle**, locate the **Size and Shape** section.
- 3 In the **Width** text field, type 0.1.
- 4 In the **Height** text field, type 0.02.

Work Plane 2 (wp2) > Union 1 (uni1)

- 1 In the **Work Plane** toolbar, click  **Booleans and Partitions** and choose **Union**.
- 2 Select the objects **r2** and **r3** only.
- 3 In the **Settings** window for **Union**, locate the **Union** section.
- 4 Clear the **Keep interior boundaries** checkbox.

Revolve 2 (rev2)

- 1 In the **Model Builder** window, right-click **Geometry 1** and choose **Revolve**.
- 2 In the **Settings** window for **Revolve**, locate the **Revolution Angles** section.
- 3 Click the **Angles** button.
- 4 In the **End angle** text field, type 90.
- 5 Locate the **Revolution Axis** section. Find the **Direction of revolution axis** subsection. In the **xw** text field, type 1.
- 6 In the **yw** text field, type 0.

Next, some ridges in the mechanical joint will be constructed.

Cylinder 1 (cyl1)



- 1 In the **Geometry** toolbar, click  **Cylinder**.
- 2 In the **Settings** window for **Cylinder**, locate the **Size and Shape** section.
- 3 In the **Radius** text field, type 0.004.
- 4 In the **Height** text field, type 0.05.
- 5 Locate the **Position** section. In the **y** text field, type 0.02.

- 6 In the **z** text field, type 0.055.
- 7 Locate the **Axis** section. From the **Axis type** list, choose **x-axis**.

Array 1 (arr1)

- 1 In the **Geometry** toolbar, click  **Transforms** and choose **Array**.
- 2 Select the object **cyll** only.
- 3 In the **Settings** window for **Array**, locate the **Size** section.
- 4 In the **z size** text field, type 4.
- 5 Locate the **Displacement** section. In the **z** text field, type 0.012.

Ferromagnetic Domain

- 1 In the **Geometry** toolbar, click  **Booleans and Partitions** and choose **Difference**.
- 2 In the **Settings** window for **Difference**, type Ferromagnetic Domain in the **Label** text field.
- 3 Click the  **Zoom Extents** button in the **Graphics** toolbar.
- 4 Click the  **Wireframe Rendering** button in the **Graphics** toolbar.
- 5 Select the object **rev2(2)** only.

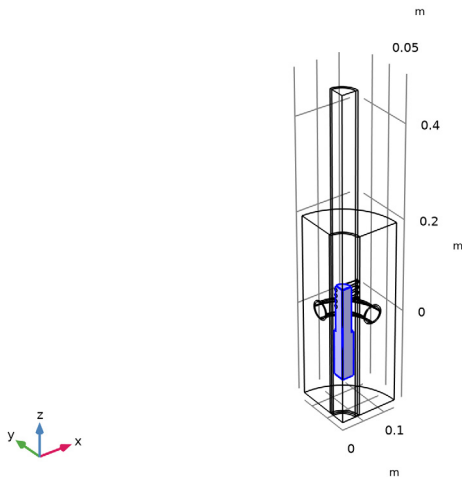

- 6 Locate the **Difference** section. Click to select the  **Activate Selection** toggle button for **Objects to subtract**.
- 7 Select the objects **arr1(1,1,1)**, **arr1(1,1,2)**, **arr1(1,1,3)**, and **arr1(1,1,4)** only. That is, all four small cylinders.

8 Locate the **Selections of Resulting Entities** section. Select the **Resulting objects selection** checkbox.

9 Click  **Build Selected**.

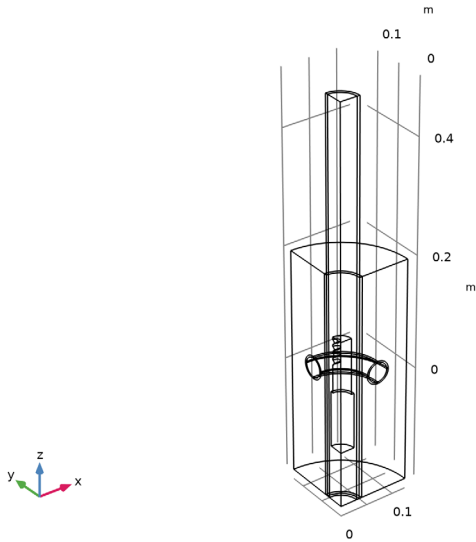

Moving Domains

1 In the **Geometry** toolbar, click  **Booleans and Partitions** and choose **Union**.

2 In the **Settings** window for **Union**, type Moving Domains in the **Label** text field.

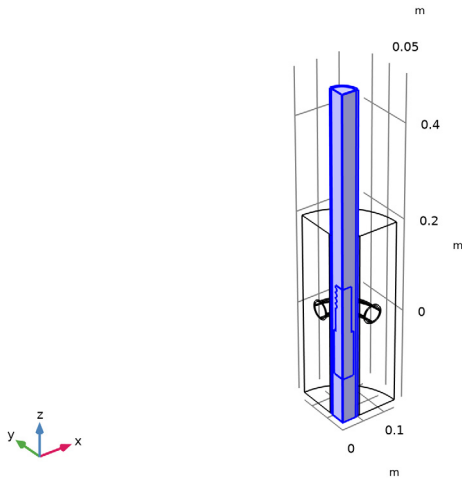

3 Select the objects **dif1** and **rev2(1)** only.



4 Locate the **Selections of Resulting Entities** section. Select the **Resulting objects selection** checkbox.

Now, the geometry is just about finished. What remains is forming an assembly, which is done by changing the (default) **Form Union** node.

Form Union (fin)

- 1 In the **Model Builder** window, under **Component 1 (comp1) > Geometry 1** click **Form Union (fin)**.
- 2 In the **Settings** window for **Form Union/Assembly**, locate the **Form Union/Assembly** section.
- 3 From the **Action** list, choose **Form an assembly**.
- 4 Clear the **Fast pair detection for stacked objects** checkbox.
- 5 In the **Geometry** toolbar, click  **Build All**.
- 6 Click the  **Show Grid** button in the **Graphics** toolbar.

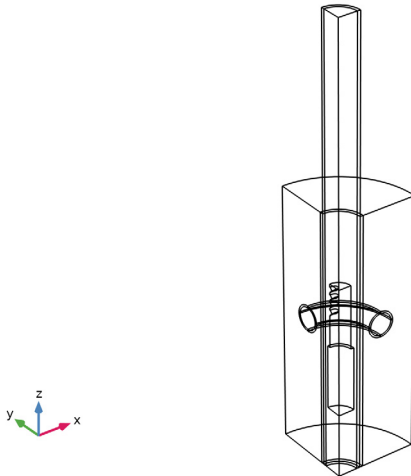

7 Click the  **Go to Default View** button in the **Graphics** toolbar.



Compare the wireframe rendering of the geometry with the figure above. Note that mirror symmetries will be utilized, which is why only a quarter of the full mechanical part is modeled. Note also that an **Identity Boundary Pair** node was automatically added under **Definitions**. This is a result of forming an assembly instead of a union while finalizing the geometry and is generally necessary when working with moving parts. Next, create some selections.

DEFINITIONS

Adjacent 1

- 1 In the **Definitions** toolbar, click  **Adjacent**.
- 2 In the **Settings** window for **Adjacent**, locate the **Input Entities** section.
- 3 Under **Input selections**, click  **Add**.
- 4 In the **Add** dialog, select **Ferromagnetic Domain** in the **Input selections** list.
- 5 Click **OK**.



Explicit 1

- 1 In the **Definitions** toolbar, click  **Explicit**.
- 2 In the **Settings** window for **Explicit**, locate the **Input Entities** section.
- 3 From the **Geometric entity level** list, choose **Boundary**.

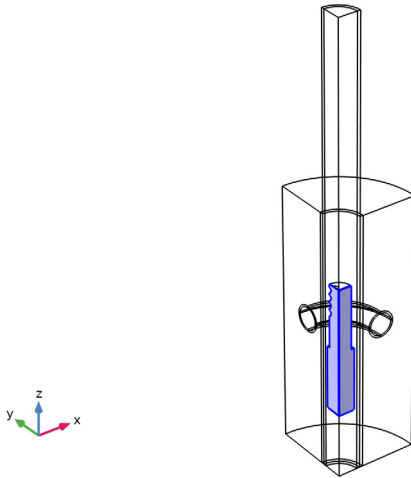
4 Select Boundaries 4 and 5 only.



Difference 1

- 1 In the **Definitions** toolbar, click  **Difference**.
- 2 In the **Settings** window for **Difference**, locate the **Geometric Entity Level** section.
- 3 From the **Level** list, choose **Boundary**.
- 4 Locate the **Input Entities** section. Under **Selections to add**, click  **Add**.
- 5 In the **Add** dialog, select **Adjacent 1** in the **Selections to add** list.
- 6 Click **OK**.
- 7 In the **Settings** window for **Difference**, locate the **Input Entities** section.
- 8 Under **Selections to subtract**, click  **Add**.
- 9 In the **Add** dialog, select **Explicit 1** in the **Selections to subtract** list.
- 10 Click **OK**.

Coil

- 1 In the **Definitions** toolbar, click  **Explicit**.
- 2 In the **Settings** window for **Explicit**, type `Coil` in the **Label** text field.

3 Select Domains 6, 7, 9, and 10 only.

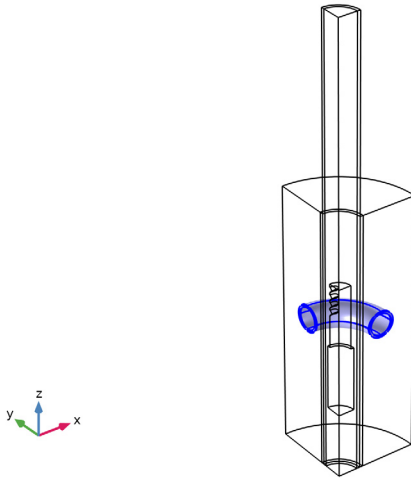

Input

- 1 In the **Definitions** toolbar, click  **Cylinder**.
- 2 In the **Settings** window for **Cylinder**, type Input in the **Label** text field.
- 3 Locate the **Geometric Entity Level** section. From the **Level** list, choose **Boundary**.
- 4 Locate the **Size and Shape** section. In the **Outer radius** text field, type 0.02.
- 5 In the **Top distance** text field, type 0.
- 6 In the **Bottom distance** text field, type 0.
- 7 Locate the **Position** section. In the **x** text field, type 0.07.
- 8 In the **z** text field, type 0.02.
- 9 Locate the **Axis** section. From the **Axis type** list, choose **y-axis**.
- 10 Locate the **Output Entities** section. From the **Include entity if** list, choose **All vertices inside cylinder**.

Output

- 1 Right-click **Input** and choose **Duplicate**.
- 2 In the **Settings** window for **Cylinder**, type Output in the **Label** text field.
- 3 Locate the **Position** section. In the **x** text field, type 0.
- 4 In the **y** text field, type 0.07.

5 Locate the **Axis** section. From the **Axis type** list, choose **x-axis**.

Create two new views.

View 4

1 In the **Model Builder** window, right-click **Definitions** and choose **View**.

2 In the **Settings** window for **View**, locate the **View** section.

3 Select the **Wireframe rendering** checkbox.

4 Clear the **Show grid** checkbox.

5 Select the **Lock camera** checkbox.

Camera

1 In the **Model Builder** window, expand the **View 4** node, then click **Camera**.

2 In the **Settings** window for **Camera**, locate the **Camera** section.

3 In the **Zoom angle** text field, type 9.

4 Locate the **Position** section. In the **x** text field, type 1.4.

5 In the **y** text field, type 0.4.

6 In the **z** text field, type 3.7.

7 Locate the **Up Vector** section. In the **x** text field, type 0.

8 In the **y** text field, type 1.

9 In the **z** text field, type 0.

10 Locate the **View Offset** section. In the **x** text field, type 0.

11 In the **y** text field, type 0.

12 Click  **Update**.

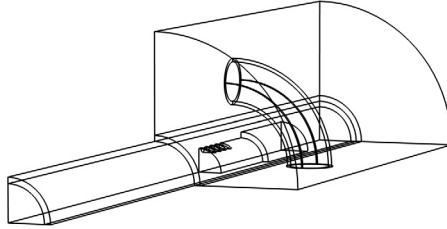

View 5

In the **Model Builder** window, under **Component 1 (comp1) > Definitions** right-click **View 4** and choose **Duplicate**.

Camera

- 1 In the **Model Builder** window, expand the **View 5** node, then click **Camera**.
- 2 In the **Settings** window for **Camera**, locate the **Camera** section.
- 3 In the **Zoom angle** text field, type 16.
- 4 Locate the **Position** section. In the **x** text field, type 0.9.
- 5 In the **z** text field, type 0.55.
- 6 Locate the **Target** section. In the **x** text field, type 0.
- 7 In the **y** text field, type 0.
- 8 In the **z** text field, type 0.
- 9 Locate the **Center of Rotation** section. In the **x** text field, type 0.
- 10 In the **y** text field, type 0.
- 11 In the **z** text field, type 0.

12 Click  **Update**.

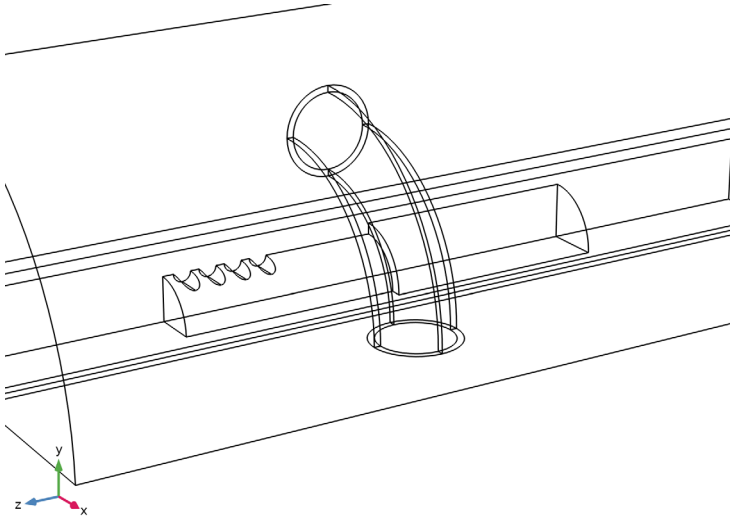

13 In the **Graphics** window toolbar, click ▼ next to  **Go to Default View**, then choose **Go to View 4**.

The identity boundary pair was automatically configured with the correct boundary selections when the assembly was formed in the geometry. Look at these selections by clicking on the **Identity Boundary Pair** node.

Identity Boundary Pair 1 (ap1)

In the **Model Builder** window, under **Component 1 (comp1)** > **Definitions** click **Identity Boundary Pair 1 (ap1)**.

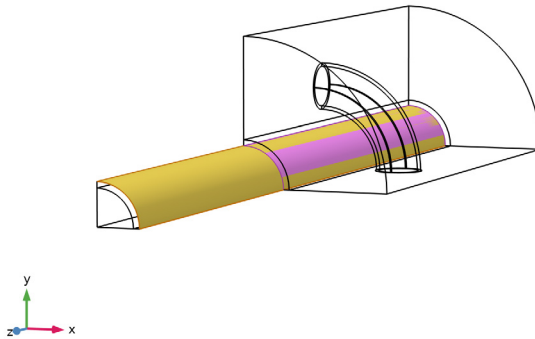

MOVING MESH

Prescribed Deformation 1

- 1 In the **Model Builder** window, under **Component 1 (comp1)** > **Moving Mesh** click **Prescribed Deformation 1**.
- 2 In the **Settings** window for **Prescribed Deformation**, locate the **Geometric Entity Selection** section.
- 3 From the **Selection** list, choose **Moving Domains**.
- 4 Locate the **Prescribed Deformation** section. Specify the dx vector as

$-vel*t$	Z
----------	---

Next, configure the magnetic fields interface. Start by changing from the default quadratic discretization to linear.

MAGNETIC FIELDS (MF)

- 1 In the **Model Builder** window, under **Component 1 (comp1)** click **Magnetic Fields (mf)**.
- 2 In the **Settings** window for **Magnetic Fields**, click to expand the **Discretization** section.

3 From the **Magnetic vector potential** list, choose **Linear**.

Free Space 1

1 In the **Model Builder** window, under **Component 1 (comp1) > Magnetic Fields (mf)** click **Free Space 1**.

2 In the **Settings** window for **Free Space**, locate the **Stabilization** section.

3 From the σ_{stab} list, choose **User defined**.

Magnetic Continuity 1

1 In the **Physics** toolbar, click  **Pairs** and choose **Magnetic Continuity**.

2 In the **Settings** window for **Magnetic Continuity**, locate the **Pair Selection** section.

3 Click **+ Add**.

4 In the **Add** dialog, select **Identity Boundary Pair 1 (ap1)** in the **Pairs** list.

5 Click **OK**.

Domain Coil 1

1 In the **Physics** toolbar, click  **Domains** and choose **Domain Coil**.

2 In the **Settings** window for **Domain Coil**, locate the **Domain Selection** section.

3 From the **Selection** list, choose **Coil**.

4 Locate the **Coil** section. In the I_{coil} text field, type I0.

5 In the **Model Builder** window, expand the **Domain Coil 1** node.

Input 1

1 In the **Model Builder** window, expand the **Component 1 (comp1) > Magnetic Fields (mf) > Domain Coil 1 > Geometry Analysis 1** node, then click **Input 1**.

2 In the **Settings** window for **Input**, locate the **Boundary Selection** section.

3 From the **Selection** list, choose **Input**.

Geometry Analysis 1

In the **Model Builder** window, click **Geometry Analysis 1**.

Output 1

1 In the **Physics** toolbar, click  **Attributes** and choose **Output**.

2 In the **Settings** window for **Output**, locate the **Boundary Selection** section.

3 From the **Selection** list, choose **Output**.

For the final addition to the Magnetic Fields interface, create the domain for the mechanical joint where the Curie point effects will be introduced.

Ampère's Law in Solids I

- 1 In the **Physics** toolbar, click  **Domains** and choose **Ampère's Law in Solids**.
- 2 In the **Settings** window for **Ampère's Law in Solids**, locate the **Domain Selection** section.
- 3 From the **Selection** list, choose **Ferromagnetic Domain**.
- 4 Locate the **Constitutive Relation B-H** section. From the μ_r list, choose **User defined**. In the associated text field, type $1+\mu_r0fB(mf.normB)*CuriePermFact(T)$.

HEAT TRANSFER IN SOLIDS (HT)

- 1 In the **Model Builder** window, under **Component 1 (comp1)** click **Heat Transfer in Solids (ht)**.
- 2 In the **Settings** window for **Heat Transfer in Solids**, locate the **Domain Selection** section.
- 3 From the **Selection** list, choose **Ferromagnetic Domain**.
- 4 Click to expand the **Discretization** section. From the **Temperature** list, choose **Linear**.

Solid I

- 1 In the **Model Builder** window, under **Component 1 (comp1)** > **Heat Transfer in Solids (ht)** click **Solid I**.
- 2 In the **Settings** window for **Solid**, locate the **Thermodynamics, Solid** section.
- 3 From the C_p list, choose **User defined**. In the associated text field, type $(440+2e5*CurieHeatFact(T))*1[J/(kg*K)]$.

Continuity I

- 1 In the **Model Builder** window, click **Continuity I**.
- 2 In the **Settings** window for **Continuity**, locate the **Advanced** section.
- 3 Select the **Disconnect pair** checkbox.

Heat Flux I

- 1 In the **Physics** toolbar, click  **Boundaries** and choose **Heat Flux**.
- 2 In the **Settings** window for **Heat Flux**, locate the **Boundary Selection** section.
- 3 From the **Selection** list, choose **Difference I**.
- 4 Locate the **Heat Flux** section. From the **Flux type** list, choose **Convective heat flux**.
- 5 In the h text field, type 10.



Surface-to-Ambient Radiation I

- 1 In the **Physics** toolbar, click  **Boundaries** and choose **Surface-to-Ambient Radiation**.
- 2 In the **Settings** window for **Surface-to-Ambient Radiation**, locate the **Boundary Selection** section.

- 3 From the **Selection** list, choose **Difference 1**.
- 4 Locate the **Surface-to-Ambient Radiation** section. From the ϵ list, choose **User defined**. In the associated text field, type 0.9.

MULTIPHYSICS

Electromagnetic Heating 1 (emh1)

- 1 In the **Physics** toolbar, click  **Multiphysics Couplings** and choose **Domain > Electromagnetic Heating**.
- 2 In the **Settings** window for **Electromagnetic Heating**, locate the **Domain Selection** section.
- 3 From the **Selection** list, choose **Ferromagnetic Domain**.
- 4 Locate the **Boundary Selection** section. Click  **Clear Selection**.

ADD MATERIAL FROM LIBRARY

In the **Home** toolbar, click  **Windows** and choose **Add Material from Library**.

ADD MATERIAL

- 1 Go to the **Add Material** window.
- 2 In the tree, select **Built-in > Air**.
- 3 Click the **Add to Component** button in the window toolbar.
- 4 In the tree, select **Built-in > Iron**.
- 5 Click the **Add to Component** button in the window toolbar.
- 6 In the tree, select **Built-in > Copper**.
- 7 Click the **Add to Component** button in the window toolbar.
- 8 In the **Home** toolbar, click  **Add Material** to close the **Add Material** window.

MATERIALS

Copper (mat3)

- 1 In the **Settings** window for **Material**, locate the **Geometric Entity Selection** section.
- 2 From the **Selection** list, choose **Coil**.



Iron (mat2)

- 1 In the **Model Builder** window, click **Iron (mat2)**.
- 2 In the **Settings** window for **Material**, locate the **Geometric Entity Selection** section.
- 3 From the **Selection** list, choose **Ferromagnetic Domain**.

MESH 1

- 1 In the **Model Builder** window, under **Component 1 (comp1)** click **Mesh 1**.
- 2 In the **Settings** window for **Mesh**, locate the **Sequence Type** section.
- 3 From the list, choose **User-controlled mesh**.
- 4 In the **Mesh** toolbar, click  **Clear Sequence**.

Mapped 1

- 1 In the **Mesh** toolbar, click  **More Generators** and choose **Mapped**.
- 2 In the **Settings** window for **Mapped**, locate the **Boundary Selection** section.
- 3 From the **Selection** list, choose **Input**.
- 4 Click the  **Go to Default View** button in the **Graphics** toolbar.
- 5 Click the  **Zoom to Selection** button in the **Graphics** toolbar.

Distribution 1

- 1 Right-click **Mapped 1** and choose **Distribution**.
- 2 Select Edge 106 only.

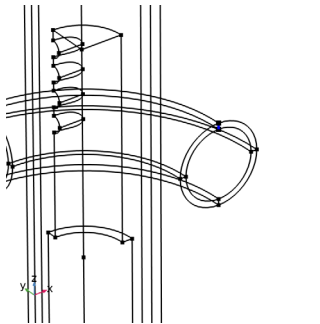

- 3 In the **Settings** window for **Distribution**, locate the **Distribution** section.
- 4 In the **Number of elements** text field, type 2.

Distribution 2

- 1 In the **Model Builder** window, right-click **Mapped 1** and choose **Distribution**.

2 Select Edges 99, 100, 104, and 108 only.

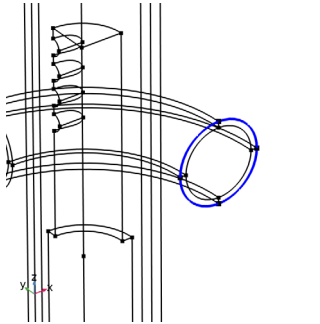

3 In the **Settings** window for **Distribution**, locate the **Distribution** section.

4 In the **Number of elements** text field, type 3.

Swept 1

1 In the **Mesh** toolbar, click  **Swept**.

2 In the **Settings** window for **Swept**, locate the **Domain Selection** section.

3 From the **Geometric entity level** list, choose **Domain**.

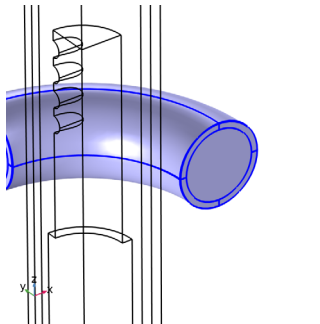

4 Select Domains 6–10 only.



Distribution 1

1 Right-click **Swept 1** and choose **Distribution**.

2 Right-click **Distribution 1** and choose **Build Selected**.

- 3 In the **Settings** window for **Distribution**, in the **Graphics** window toolbar, click  next to  **Go to Default View**, then choose **Go to View 5**.

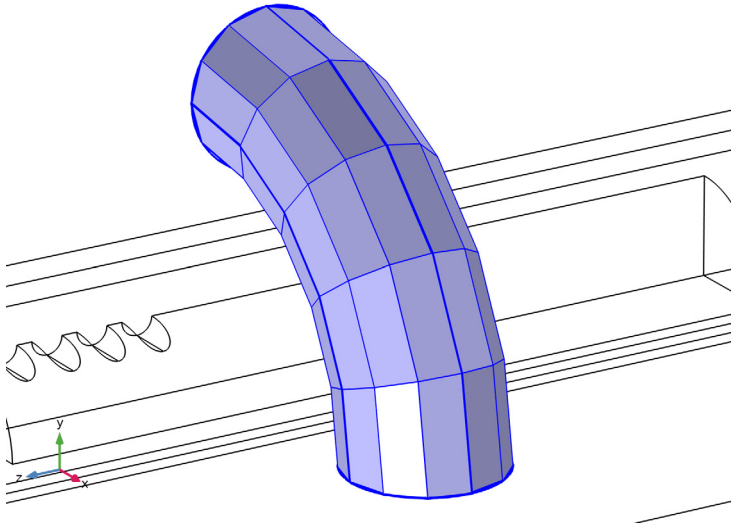

Free Tetrahedral 1

In the **Mesh** toolbar, click  **Free Tetrahedral**.

Size 1



- 1 Right-click **Free Tetrahedral 1** and choose **Size**.
- 2 In the **Settings** window for **Size**, locate the **Geometric Entity Selection** section.
- 3 From the **Geometric entity level** list, choose **Domain**.
- 4 From the **Selection** list, choose **Ferromagnetic Domain**.
- 5 Locate the **Element Size** section. Click the **Custom** button.
- 6 Locate the **Element Size Parameters** section.
- 7 Select the **Maximum element size** checkbox. In the associated text field, type $de1_sat*2$.

Size 2

- 1 Right-click **Size 1** and choose **Duplicate**.
- 2 In the **Settings** window for **Size**, locate the **Geometric Entity Selection** section.
- 3 From the **Geometric entity level** list, choose **Boundary**.
- 4 From the **Selection** list, choose **Difference 1**.

- 5 Locate the **Element Size Parameters** section. In the **Maximum element size** text field, type del_sat.
- 6 Select the **Maximum element growth rate** checkbox. In the associated text field, type 1.1.

Size 3

- 1 In the **Model Builder** window, right-click **Free Tetrahedral 1** and choose **Size**.
- 2 In the **Settings** window for **Size**, in the **Graphics** window toolbar, click  next to  **Go to Default View**, then choose **Go to View 4**.
- 3 Locate the **Geometric Entity Selection** section. From the **Geometric entity level** list, choose **Domain**.
- 4 Select Domains 3 and 4 only.

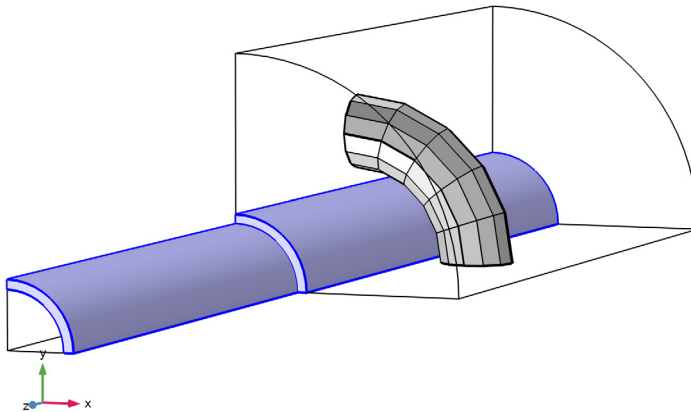



- 5 Locate the **Element Size** section. Click the **Custom** button.
- 6 Locate the **Element Size Parameters** section.
- 7 Select the **Maximum element size** checkbox. In the associated text field, type 0.01.
- 8 Select the **Minimum element size** checkbox. In the associated text field, type 0.01.

Boundary Layers 1

- 1 In the **Mesh** toolbar, click  **Boundary Layers**.
- 2 In the **Settings** window for **Boundary Layers**, locate the **Geometric Entity Selection** section.

- 3 From the **Geometric entity level** list, choose **Domain**.
- 4 From the **Selection** list, choose **Ferromagnetic Domain**.

Boundary Layer Properties

- 1 In the **Model Builder** window, click **Boundary Layer Properties**.
- 2 In the **Settings** window for **Boundary Layer Properties**, locate the **Boundary Selection** section.
- 3 From the **Selection** list, choose **Difference 1**.
- 4 Locate the **Layers** section. In the **Number of layers** text field, type 3.
- 5 From the **Thickness specification** list, choose **First layer**.
- 6 In the **Thickness** text field, type $del_sat/10$.
- 7 In the **Model Builder** window, right-click **Mesh 1** and choose **Build All**.
- 8 In the **Settings** window for **Mesh**, in the **Graphics** window toolbar, click  next to  **Go to Default View**, then choose **Go to View 4**.

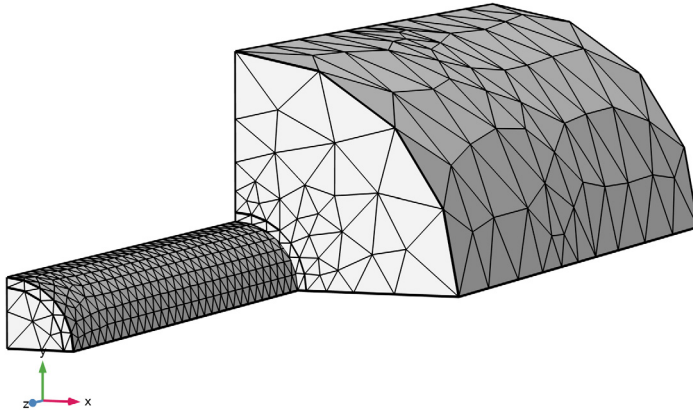

INITIALIZATION (MAGNETIC)

- 1 In the **Model Builder** window, click **Study 1**.
- 2 In the **Settings** window for **Study**, type Initialization (Magnetic) in the **Label** text field.
- 3 Locate the **Study Settings** section. Clear the **Generate default plots** checkbox.



Step 2: Coil Geometry Analysis

- 1 In the **Study** toolbar, click  **More Study Steps** and choose **Other > Coil Geometry Analysis**.
- 2 Drag and drop above **Step 2: Frequency Domain**.

Step 2: Frequency Domain

- 1 In the **Model Builder** window, click **Step 2: Frequency Domain**.
- 2 In the **Settings** window for **Frequency Domain**, locate the **Study Settings** section.
- 3 In the **Frequencies** text field, type f .

Solution 1 (sol1)

- 1 In the **Study** toolbar, click  **Show Default Solver**.
- 2 In the **Model Builder** window, expand the **Solution 1 (sol1)** node, then click **Compile Equations: Frequency Domain**.
- 3 In the **Settings** window for **Compile Equations**, locate the **Study and Step** section.
- 4 Select the **Split complex variables in real and imaginary parts** checkbox.
- 5 Click  **Run**.

RESULTS

Initialization

- 1 In the **Model Builder** window, expand the **Results** node.
- 2 Right-click **Results** and choose **3D Plot Group**.
- 3 In the **Settings** window for **3D Plot Group**, type Initialization in the **Label** text field.
- 4 Locate the **Plot Settings** section. From the **View** list, choose **View 5**.
- 5 Locate the **Color Legend** section. Select the **Show units** checkbox.

Volume 1

- 1 Right-click **Initialization** and choose **Volume**.
- 2 In the **Settings** window for **Volume**, click **Replace Expression** in the upper-right corner of the **Expression** section. From the menu, choose **Component 1 (comp1) > Magnetic Fields > Heating and losses > mf.Qrh - Volumetric loss density, electric - W/m³**.
- 3 Locate the **Expression** section. In the **Unit** field, type W/cm^3 .
- 4 Locate the **Coloring and Style** section. From the **Color table** list, choose **HeatCamera**.

Selection 1

- 1 Right-click **Volume 1** and choose **Selection**.

- 2 In the **Settings** window for **Selection**, locate the **Selection** section.
- 3 From the **Selection** list, choose **Ferromagnetic Domain**.

Slice 1

- 1 In the **Model Builder** window, right-click **Initialization** and choose **Slice**.
- 2 In the **Settings** window for **Slice**, locate the **Plane Data** section.
- 3 From the **Entry method** list, choose **Coordinates**.
- 4 Locate the **Coloring and Style** section. From the **Color table** list, choose **Prism**.



Deformation 1

- 1 Right-click **Slice 1** and choose **Deformation**.
- 2 In the **Settings** window for **Deformation**, locate the **Expression** section.
- 3 In the **x-component** text field, type -1.

Selection 1

- 1 In the **Model Builder** window, right-click **Slice 1** and choose **Selection**.
- 2 In the **Settings** window for **Selection**, locate the **Selection** section.
- 3 From the **Selection** list, choose **Ferromagnetic Domain**.
- 4 In the **Initialization** toolbar, click  **Plot** and compare the resulting plot with [Figure 2](#).

ADD STUDY

- 1 In the **Home** toolbar, click  **Add Study** to open the **Add Study** window.
- 2 Go to the **Add Study** window.
- 3 Find the **Studies** subsection. In the **Select Study** tree, select **Preset Studies for Selected Multiphysics > Frequency–Transient**.
- 4 Click the **Add Study** button in the window toolbar.
- 5 In the **Home** toolbar, click  **Add Study** to close the **Add Study** window.

INDUCTION HEATING MOVING LOAD

- 1 In the **Settings** window for **Study**, type Induction Heating Moving Load in the **Label** text field.
- 2 Locate the **Study Settings** section. Clear the **Generate default plots** checkbox.

Step 2: Coil Geometry Analysis

- 1 In the **Study** toolbar, click  **More Study Steps** and choose **Other > Coil Geometry Analysis**.

2 Drag and drop above **Step 2: Frequency–Transient**.

The Coil Geometry Analysis study step only calculates a scalar potential for the current in the coil. The remaining dependent variables (for example the magnetic vector potential and the temperature) will be taken from the initialization study.

- 3** In the **Settings** window for **Coil Geometry Analysis**, click to expand the **Values of Dependent Variables** section.
- 4** Find the **Values of variables not solved for** subsection. From the **Settings** list, choose **User controlled**.
- 5** From the **Method** list, choose **Solution**.
- 6** From the **Study** list, choose **Initialization (Magnetic), Frequency Domain**.

Step 2: Frequency–Transient

- 1** In the **Model Builder** window, click **Step 2: Frequency–Transient**.
- 2** In the **Settings** window for **Frequency–Transient**, locate the **Study Settings** section.
- 3** In the **Output times** text field, type range (0,0.2,5) range (5.5,0.5,60).
- 4** In the **Frequency** text field, type f.

This frequency-transient study combines a time-dependent study for the Heat Transfer in Solids interface with a frequency study for the Magnetic Fields interface. The time-averaged heating from the magnetic fields will be used to calculate the temperature in the transient study. At each time step, the temperature will be used to calculate a new magnetic field which, consequently, gives a new value for the heat. Before computing, however, the default solver should be modified slightly to properly handle the nonlinearities in the model.

Solution 3 (sol3)

- 1** In the **Study** toolbar, click  **Show Default Solver**.
- 2** In the **Model Builder** window, expand the **Solution 3 (sol3)** node, then click **Compile Equations: Frequency–Transient**.
- 3** In the **Settings** window for **Compile Equations**, locate the **Study and Step** section.
- 4** Select the **Split complex variables in real and imaginary parts** checkbox.
- 5** In the **Model Builder** window, under **Induction Heating Moving Load** > **Solver Configurations** > **Solution 3 (sol3)** click **Dependent Variables 2**.
- 6** In the **Settings** window for **Dependent Variables**, locate the **Scaling** section.
- 7** From the **Method** list, choose **Initial-value based**.



- 8 In the **Model Builder** window, under **Induction Heating Moving Load > Solver Configurations > Solution 3 (sol3)** click **Time-Dependent Solver 1**.
- 9 In the **Settings** window for **Time-Dependent Solver**, click to expand the **Time Stepping** section.
- 10 From the **Steps taken by solver** list, choose **Strict**.
- 11 Right-click **Induction Heating Moving Load > Solver Configurations > Solution 3 (sol3) > Time-Dependent Solver 1** and choose **Fully Coupled**.
- 12 In the **Settings** window for **Fully Coupled**, click to expand the **Method and Termination** section.
- 13 From the **Jacobian update** list, choose **On every iteration**.
- 14 Click  **Run**.

RESULTS

Point Temperatures

- 1 In the **Results** toolbar, click  **ID Plot Group**.
- 2 In the **Settings** window for **ID Plot Group**, type **Point Temperatures** in the **Label** text field.
- 3 Locate the **Data** section. From the **Dataset** list, choose **Induction Heating Moving Load/ Solution 3 (sol3)**.

Point Graph 1

- 1 Right-click **Point Temperatures** and choose **Point Graph**.
- 2 In the **Settings** window for **Point Graph**, in the **Graphics** window toolbar, click  next to  **Go to Default View**, then choose **Go to View 5**.

- 3 Select Points 4, 11, 15, 19, 21, 31, and 33 only.

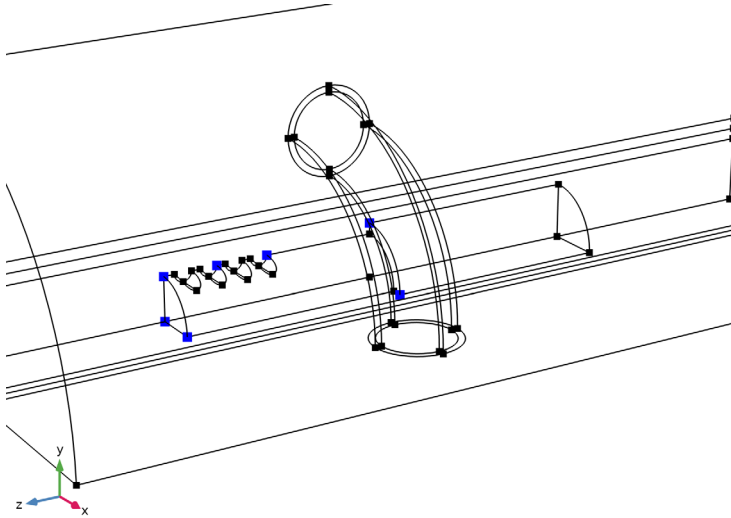

- 4 Locate the **y-Axis Data** section. In the **Expression** text field, type T.
- 5 From the **Unit** list, choose °C.
- 6 Click to expand the **Legends** section. Select the **Show legends** checkbox.
- 7 In the **Point Temperatures** toolbar, click  **Plot**.

Compare the temperatures with [Figure 3](#). Next, create some datasets for the remaining plot groups. The first new dataset will be using the **Material (X, Y, Z)** frame with a selection of the ferromagnetic domain. This reference frame ignores the translation from the moving mesh, which allows an analysis of the moving part without it moving out of frame. Furthermore, the symmetries of the model will now be utilized using the **Mirror 3D** dataset.

Induction Heating Moving Load/Solution 2 (Ferromagnetic Domain)

- 1 In the **Model Builder** window, expand the **Results > Datasets** node.
- 2 Right-click **Results > Datasets > Induction Heating Moving Load/Solution 3 (sol3)** and choose **Duplicate**.
- 3 In the **Settings** window for **Solution**, type Induction Heating Moving Load/Solution 2 (Ferromagnetic Domain) in the **Label** text field.
- 4 Locate the **Solution** section. From the **Frame** list, choose **Material (X, Y, Z)**.

Selection

- 1 In the **Results** toolbar, click  **Attributes** and choose **Selection**.

- 2 In the **Settings** window for **Selection**, locate the **Geometric Entity Selection** section.
- 3 From the **Geometric entity level** list, choose **Domain**.
- 4 From the **Selection** list, choose **Ferromagnetic Domain**.

Mirror 3D 1

- 1 In the **Results** toolbar, click  **More Datasets** and choose **Mirror 3D**.
- 2 In the **Settings** window for **Mirror 3D**, locate the **Data** section.
- 3 From the **Dataset** list, choose **Induction Heating Moving Load/ Solution 2 (Ferromagnetic Domain) (sol3)**.
- 4 Locate the **Plane Data** section. From the **Plane** list, choose **ZX-planes**.

Mirror 3D 2

- 1 In the **Results** toolbar, click  **More Datasets** and choose **Mirror 3D**.
- 2 In the **Settings** window for **Mirror 3D**, locate the **Data** section.
- 3 From the **Dataset** list, choose **Mirror 3D 1**.

Initialization (Magnetic)/Solution 1 (Current Domain)

- 1 In the **Model Builder** window, under **Results > Datasets** right-click **Initialization (Magnetic)/Solution 1 (sol1)** and choose **Duplicate**.
- 2 In the **Settings** window for **Solution**, type Initialization (Magnetic)/Solution 1 (Current Domain) in the **Label** text field.

Selection

- 1 In the **Results** toolbar, click  **Attributes** and choose **Selection**.
- 2 In the **Settings** window for **Selection**, locate the **Geometric Entity Selection** section.
- 3 From the **Geometric entity level** list, choose **Domain**.
- 4 From the **Selection** list, choose **Coil**.

Surface Temperature

- 1 In the **Results** toolbar, click  **3D Plot Group**.
- 2 In the **Settings** window for **3D Plot Group**, type Surface Temperature in the **Label** text field.
- 3 Locate the **Data** section. From the **Dataset** list, choose **Mirror 3D 2**.
- 4 From the **Time (s)** list, choose **Last (60)**.
- 5 Click to expand the **Title** section. From the **Title type** list, choose **Custom**.
- 6 Find the **User** subsection. In the **Suffix** text field, type Temperature [°C].
- 7 Find the **Type and data** subsection. Clear the **Type** checkbox.

- 8 Clear the **Description** checkbox.
- 9 Clear the **Unit** checkbox.
- 10 Find the **Layout** subsection. Clear the **Use parameter indicator for solution and phase** checkbox.
- 11 Locate the **Plot Settings** section. From the **View** list, choose **View 5**.



Surface 1

- 1 Right-click **Surface Temperature** and choose **Surface**.
- 2 In the **Settings** window for **Surface**, locate the **Expression** section.
- 3 In the **Expression** text field, type T.
- 4 From the **Unit** list, choose °C.
- 5 Locate the **Coloring and Style** section. From the **Color table** list, choose **GrayBody**.
- 6 In the **Surface Temperature** toolbar, click  **Plot**.

Surface Temperature

In the **Model Builder** window, click **Surface Temperature**.

Max/Min Surface 1

- 1 In the **Surface Temperature** toolbar, click  **More Plots** and choose **Max/Min Surface**.
- 2 In the **Settings** window for **Max/Min Surface**, locate the **Expression** section.
- 3 In the **Expression** text field, type T.
- 4 From the **Unit** list, choose °C.
- 5 Locate the **Display** section. From the **Display** list, choose **Max**.
- 6 Locate the **Text Format** section. In the **Prefix** text field, type Temperature, .
- 7 Select the **Include unit** checkbox.
- 8 In the **Precision** text field, type 3.
- 9 Locate the **Coloring and Style** section. From the **Color** list, choose **Magenta**.
- 10 In the **Surface Temperature** toolbar, click  **Plot**.

Max/Min Surface 2

- 1 Right-click **Max/Min Surface 1** and choose **Duplicate**.
- 2 In the **Settings** window for **Max/Min Surface**, locate the **Expression** section.
- 3 In the **Expression** text field, type mf.Qrh.
- 4 From the **Unit** list, choose **MW/m^3**.
- 5 Locate the **Text Format** section. In the **Prefix** text field, type Heat, .

6 In the **Precision** text field, type 1.

7 In the **Surface Temperature** toolbar, click  **Plot**.

Compare the surface temperature and wireframe with the figure below.

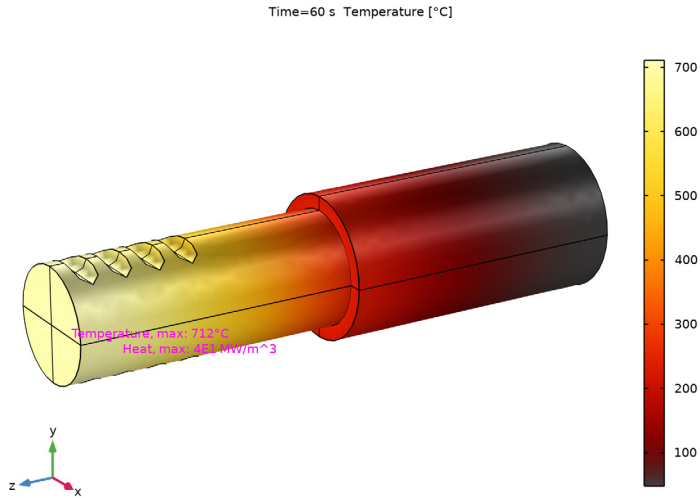

Surface 1

1 In the **Results** toolbar, click  **More Datasets** and choose **Surface**.

2 In the **Settings** window for **Surface**, locate the **Data** section.

3 From the **Dataset** list, choose **Induction Heating Moving Load/ Solution 2 (Ferromagnetic Domain) (sol3)**.

4 Locate the **Parameterization** section. From the **x- and y-axes** list, choose **ZY-plane**.

- 5 Select Boundary 4 only.

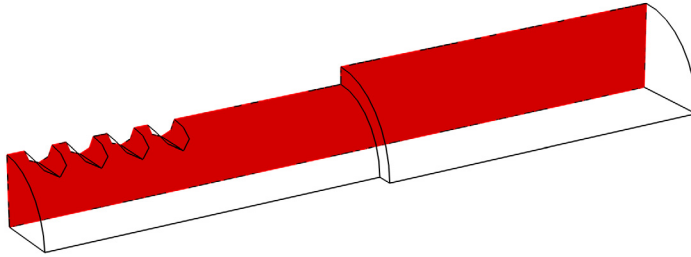

Temperature Cross Sections

- 1 In the **Results** toolbar, click  **2D Plot Group**.
- 2 In the **Settings** window for **2D Plot Group**, type Temperature Cross Sections in the **Label** text field.
- 3 Click to expand the **Title** section. From the **Title type** list, choose **Manual**.
- 4 From the **Number format** list, choose **Engineering**.
- 5 Select the **Show trailing zeros** checkbox.
- 6 In the **Precision** text field, type 3.
- 7 In the **Title** text area, type Maximum temperature reached (above) and temperature at current time step (below).
- 8 In the **Parameter indicator** text field, type $t=\text{eval}(t)$.
- 9 Locate the **Plot Settings** section. Clear the **Plot dataset edges** checkbox.
- 10 Locate the **Color Legend** section. Select the **Show units** checkbox.
- 11 From the **Position** list, choose **Right double**.

Contour 1

- 1 Right-click **Temperature Cross Sections** and choose **Contour**.
- 2 In the **Settings** window for **Contour**, locate the **Expression** section.

- 3 In the **Expression** text field, type $\min(\text{attimax}(0, t, T, \max(0, T - 700[\text{degC}])) + 700[\text{degC}], 900[\text{degC}])$.
- 4 From the **Unit** list, choose **°C**.
- 5 Locate the **Levels** section. From the **Entry method** list, choose **Levels**.
- 6 In the **Levels** text field, type $\text{range}(600, 25, 850)$.
- 7 Locate the **Coloring and Style** section. From the **Contour type** list, choose **Filled**.
- 8 From the **Color table** list, choose **AuroraBorealis**.
- 9 From the **Color table transformation** list, choose **Reverse**.

Contour 2

- 1 Right-click **Contour 1** and choose **Duplicate**.
- 2 In the **Settings** window for **Contour**, click to expand the **Title** section.
- 3 From the **Title type** list, choose **None**.
- 4 Locate the **Coloring and Style** section. Clear the **Color legend** checkbox.

Deformation 1

- 1 Right-click **Contour 2** and choose **Deformation**.
- 2 In the **Settings** window for **Deformation**, locate the **Expression** section.
- 3 In the **x-component** text field, type 0.
- 4 In the **y-component** text field, type $-2*y$.
- 5 Locate the **Scale** section.
- 6 Select the **Scale factor** checkbox. In the associated text field, type 1.

Temperature Cross Sections

Right-click **Deformation 1** and choose **Contour**.

Contour 3

- 1 In the **Settings** window for **Contour**, locate the **Expression** section.
- 2 In the **Expression** text field, type T.
- 3 From the **Unit** list, choose **°C**.
- 4 Locate the **Levels** section. From the **Entry method** list, choose **Levels**.
- 5 In the **Levels** text field, type $\text{range}(30, 30, 800)$.
- 6 Locate the **Coloring and Style** section. From the **Contour type** list, choose **Filled**.
- 7 From the **Color table** list, choose **GrayBody**.

Deformation 1

- 1 Right-click **Contour 3** and choose **Deformation**.
- 2 In the **Settings** window for **Deformation**, locate the **Expression** section.
- 3 In the **x-component** text field, type 0.
- 4 In the **y-component** text field, type $-2*Y-0.06$.
- 5 Locate the **Scale** section.
- 6 Select the **Scale factor** checkbox. In the associated text field, type 1.

Contour 4

- 1 Right-click **Contour 3** and choose **Duplicate**.
- 2 In the **Settings** window for **Contour**, locate the **Coloring and Style** section.
- 3 Clear the **Color legend** checkbox.

Deformation 1

- 1 In the **Model Builder** window, expand the **Contour 4** node, then click **Deformation 1**.
- 2 In the **Settings** window for **Deformation**, locate the **Expression** section.
- 3 In the **y-component** text field, type -0.06 .

Contour 5

- 1 In the **Model Builder** window, right-click **Temperature Cross Sections** and choose **Contour**.
- 2 In the **Settings** window for **Contour**, locate the **Expression** section.
- 3 In the **Expression** text field, type T.
- 4 From the **Unit** list, choose **°C**.
- 5 Locate the **Levels** section. From the **Entry method** list, choose **Levels**.
- 6 In the **Levels** text field, type 600 700.
- 7 Locate the **Coloring and Style** section. Select the **Level labels** checkbox.
- 8 From the **Coloring** list, choose **Uniform**.
- 9 From the **Color** list, choose **Black**.
- 10 Clear the **Color legend** checkbox.

Deformation 1



- 1 Right-click **Contour 5** and choose **Deformation**.
- 2 In the **Settings** window for **Deformation**, locate the **Expression** section.
- 3 In the **x-component** text field, type 0.
- 4 In the **y-component** text field, type $-2*Y-0.06$.

- 5 Locate the **Scale** section.
- 6 Select the **Scale factor** checkbox. In the associated text field, type 1.

Contour 6

- 1 In the **Model Builder** window, under **Results > Temperature Cross Sections** right-click **Contour 5** and choose **Duplicate**.
- 2 In the **Settings** window for **Contour**, click to expand the **Inherit Style** section.
- 3 From the **Plot** list, choose **Contour 5**.
- 4 Locate the **Coloring and Style** section. Clear the **Level labels** checkbox.

Deformation 1

- 1 In the **Model Builder** window, expand the **Contour 6** node, then click **Deformation 1**.
- 2 In the **Settings** window for **Deformation**, locate the **Expression** section.
- 3 In the **y-component** text field, type -0.06.
- 4 In the **Temperature Cross Sections** toolbar, click  **Plot**.
- 5 Click the  **Zoom Extents** button in the **Graphics** toolbar.

Compare the plot with [Figure 6](#) and create a new animation of the temperature evolution in the ferromagnetic domain.

Animation 1

In the **Temperature Cross Sections** toolbar, click  **Animation** and choose **Player**.

Time Dependent

- 1 In the **Results** toolbar, click  **3D Plot Group**.
- 2 In the **Settings** window for **3D Plot Group**, type **Time Dependent** in the **Label** text field.
- 3 Locate the **Data** section. From the **Dataset** list, choose **Induction Heating Moving Load/ Solution 3 (sol3)**.
- 4 From the **Time (s)** list, choose **Interpolation**.
- 5 In the **Time** text field, type 30.
- 6 Locate the **Title** section. From the **Title type** list, choose **Custom**.
- 7 From the **Number format** list, choose **Engineering**.
- 8 Select the **Show trailing zeros** checkbox.
- 9 In the **Precision** text field, type 3.
- 10 Find the **User** subsection. In the **Suffix** text field, type **Magnetic flux ([T], plane)** and **Temperature ([°C], surface)**.
- 11 Find the **Type and data** subsection. Clear the **Description** checkbox.

- 12 Clear the **Type** checkbox.
- 13 Clear the **Unit** checkbox.
- 14 Find the **Layout** subsection. Clear the **Use parameter indicator for solution and phase** checkbox.
- 15 Locate the **Plot Settings** section. From the **View** list, choose **View 5**.
- 16 Clear the **Plot dataset edges** checkbox.
- 17 Locate the **Color Legend** section. Select the **Show units** checkbox.
- 18 From the **Position** list, choose **Bottom**.

Slice 1

- 1 Right-click **Time Dependent** and choose **Slice**.
- 2 In the **Settings** window for **Slice**, locate the **Plane Data** section.
- 3 From the **Entry method** list, choose **Coordinates**.
- 4 Locate the **Coloring and Style** section. From the **Color table** list, choose **Prism**.

Deformation 1

- 1 Right-click **Slice 1** and choose **Deformation**.
- 2 In the **Settings** window for **Deformation**, locate the **Expression** section.
- 3 In the **x-component** text field, type -1.
- 4 Locate the **Scale** section.
- 5 Select the **Scale factor** checkbox. In the associated text field, type 0.02.

Volume 1

- 1 In the **Model Builder** window, right-click **Time Dependent** and choose **Volume**.
- 2 In the **Settings** window for **Volume**, locate the **Expression** section.
- 3 In the **Expression** text field, type T.
- 4 From the **Unit** list, choose **°C**.
- 5 Locate the **Coloring and Style** section. From the **Color table** list, choose **GrayBody**.

Selection 1

- 1 Right-click **Volume 1** and choose **Selection**.
- 2 In the **Settings** window for **Selection**, locate the **Selection** section.
- 3 From the **Selection** list, choose **Ferromagnetic Domain**.

Line 1

- 1 In the **Model Builder** window, right-click **Time Dependent** and choose **Line**.

- 2 In the **Settings** window for **Line**, locate the **Data** section.
- 3 From the **Dataset** list, choose **Initialization (Magnetic)/Solution 1 (sol1)**.
- 4 Locate the **Expression** section. In the **Expression** text field, type 1.
- 5 Locate the **Coloring and Style** section. From the **Coloring** list, choose **Uniform**.
- 6 From the **Color** list, choose **Black**.

Selection 1

- 1 Right-click **Line 1** and choose **Selection**.
- 2 In the **Settings** window for **Selection**, locate the **Selection** section.
- 3 From the **Geometric entity level** list, choose **Domain**.
- 4 From the **Selection** list, choose **Ferromagnetic Domain**.

Streamline 1

- 1 In the **Model Builder** window, right-click **Time Dependent** and choose **Streamline**.
- 2 In the **Settings** window for **Streamline**, click **Replace Expression** in the upper-right corner of the **Expression** section. From the menu, choose **Component 1 (comp1) > Magnetic Fields > Currents and charge > mf.Jx, ..., mf.Jz - Current density (spatial frame)**.
- 3 Locate the **Streamline Positioning** section. From the **Positioning** list, choose **Starting-point controlled**.
- 4 In the **Points** text field, type 45.
- 5 Locate the **Coloring and Style** section. Find the **Line style** subsection. From the **Type** list, choose **Ribbon**.

Selection 1

- 1 Right-click **Streamline 1** and choose **Selection**.
- 2 In the **Settings** window for **Selection**, locate the **Selection** section.
- 3 From the **Selection** list, choose **Coil**.
- 4 In the **Time Dependent** toolbar, click  **Plot**, and compare the plot with [Figure 5](#). Create a new animation.

Animation 2

- In the **Time Dependent** toolbar, click  **Animation** and choose **Player**.