



Model created in COMSOL Multiphysics 6.4

Magnetic Field of a Helmholtz Coil

Introduction

A Helmholtz coil is a parallel pair of identical circular coils spaced one radius apart and wound so that the current flows through both coils in the same direction. This winding results in a uniform magnetic field between the coils with the primary component parallel to the axis of the two coils. The uniform field is the result of the sum of the two field components parallel to the axis of the coils and the difference between the components perpendicular to the same axis.

The purpose of the device is to allow scientists and engineers to perform experiments and tests that require a known ambient magnetic field. Helmholtz field generation can be static, time varying DC, or AC, depending on the application.

Applications include canceling Earth's magnetic field for certain experiments; generating magnetic fields for determining magnetic shielding effectiveness or susceptibility of electronic equipment to magnetic fields; calibration of magnetometers and navigational equipment; and biomagnetic studies.

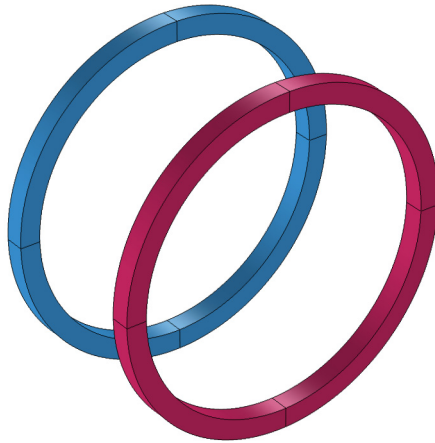

Figure 1: The Helmholtz coil consists of two coaxial circular coils, one radius apart along the axial direction. The coils carry parallel currents of equal magnitude.

Model Definition

The application shows how to compute the magnetic field with two different approaches, one using the **Magnetic Fields** interface and the other the **Magnetic Fields, Currents Only** interface. The model geometry is shown in [Figure 2](#).

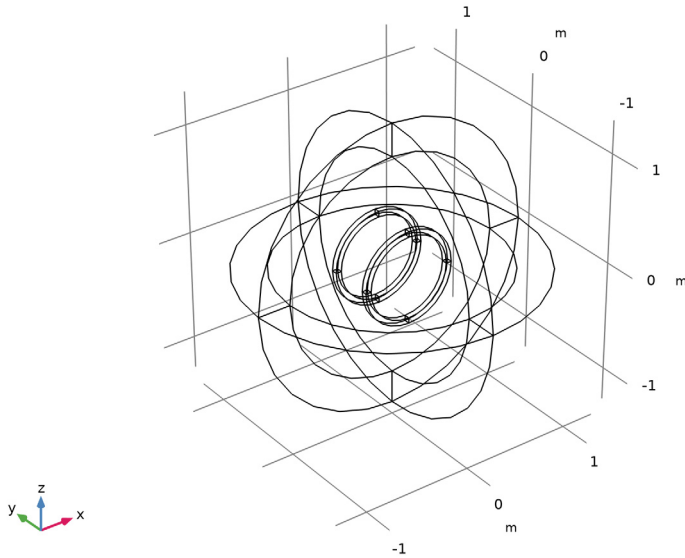

Figure 2: The model geometry.

DOMAIN EQUATIONS

Assuming static currents and fields, the magnetic vector potential \mathbf{A} must satisfy the following equation:

$$\nabla \times (\mu^{-1} \nabla \times \mathbf{A}) = \mathbf{J}_e$$

where μ is the permeability, and \mathbf{J}_e denotes the externally applied current density.

The relations between the magnetic field \mathbf{H} , the magnetic flux density \mathbf{B} and the potential are given by

$$\mathbf{B} = \nabla \times \mathbf{A}$$

$$\mathbf{H} = \mu^{-1} \mathbf{B}$$

This model uses the permeability of vacuum, that is, $\mu \approx 4\pi \times 10^{-7}$ H/m. The external current density is computed using a homogenized model for the coils, each one made by 10 wire turns and excited by a current of 0.25 mA. The currents are specified to be parallel for the two coils.

SPATIAL DERIVATIVE OF MAGNETIC FIELD

Computing the spatial derivative of the magnetic field or magnetic flux density is useful in areas such as radiology, magnetophoresis, particle accelerators, and geophysics. One of the most important use cases is the design of magnetic resonance imaging (MRI) machines, where it is necessary to analyze not only the field strength but also the spatial variation of the field. This application demonstrates how to compute the spatial derivative of the magnetic flux density in the postprocessing step.

Results and Discussion

Figure 3 shows the magnetic flux density between the coils. The flux is relatively uniform in the region between the coils. This uniformity is the main property and often the sought feature of a Helmholtz coil.

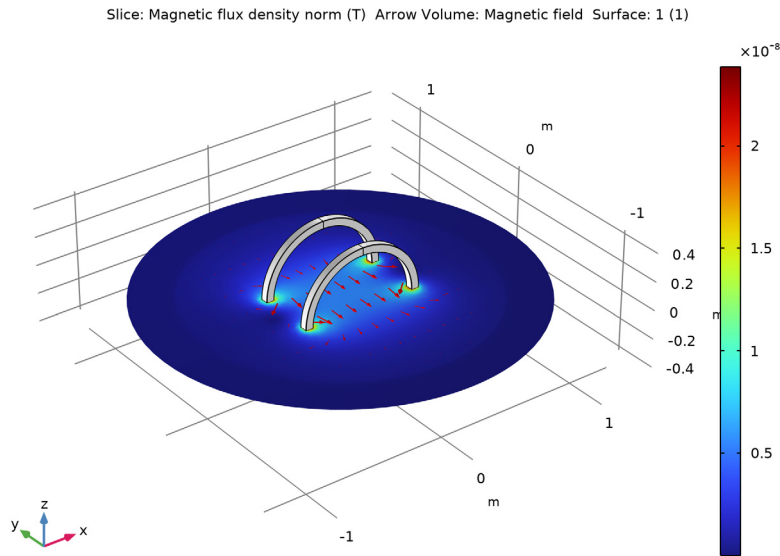

Figure 3: The slice plot shows the magnetic flux density norm. The arrows indicate the magnetic field (H) strength and direction.

Figure 4 and Figure 5 compare the results from using the two different physics interfaces.

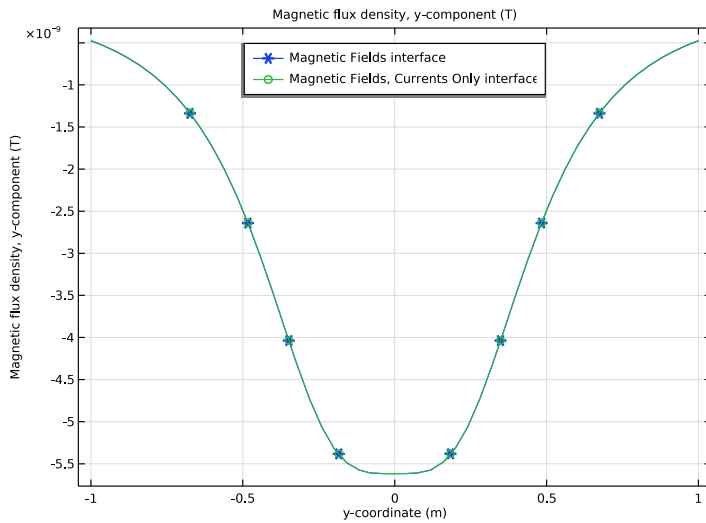

Figure 4: Comparison of the y component of the B field along the centerline of the Helmholtz coil using two different approaches.

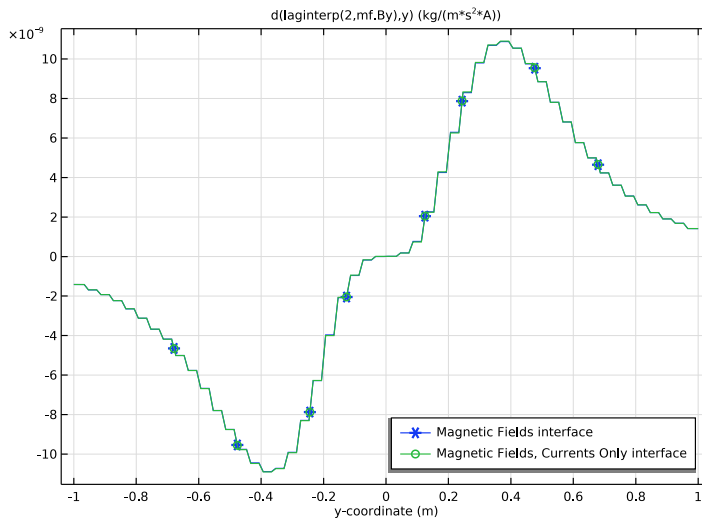



Figure 5: Comparison of the gradient (with respect to the y direction) of the y component of the B field along the centerline of the Helmholtz coil.

Application Library path: ACDC_Module/Devices,_Inductive/helmholtz_coil



Modeling Instructions

From the **File** menu, choose **New**.

NEW

In the **New** window, click  **Model Wizard**.

MODEL WIZARD

- 1 In the **Model Wizard** window, click  **3D**.
- 2 In the **Select Physics** tree, select **AC/DC** > **Electromagnetic Fields** > **Magnetic Fields (mf)**.
- 3 Click **Add**.
- 4 In the **Select Physics** tree, select **AC/DC** > **Electromagnetic Fields** > **Vector Formulations** > **Magnetic Fields, Currents Only (mfco)**.
- 5 Click **Add**.
- 6 Click  **Study**.
- 7 In the **Select Study** tree, select **General Studies** > **Stationary**.
- 8 Click  **Done**.

GLOBAL DEFINITIONS

Parameters I

- 1 In the **Model Builder** window, under **Global Definitions** click **Parameters I**.
- 2 In the **Settings** window for **Parameters**, locate the **Parameters** section.
- 3 In the table, enter the following settings:

| Name | Expression | Value | Description |
|-------------|-------------------|--------------|--------------------|
| I0 | 0.25[mA] | 2.5E-4 A | Coil current |

GEOMETRY I

Work Plane I (wp1)

- 1 In the **Geometry** toolbar, click  **Work Plane**.

2 In the **Settings** window for **Work Plane**, click  **Go to Plane Geometry**.

Work Plane 1 (wp1) > Plane Geometry

In the **Model Builder** window, click **Plane Geometry**.

Work Plane 1 (wp1) > Square 1 (sq1)

1 In the **Work Plane** toolbar, click  **Square**.

2 In the **Settings** window for **Square**, locate the **Size** section.

3 In the **Side length** text field, type 0.05.

4 Locate the **Position** section. From the **Base** list, choose **Center**.

5 In the **xw** text field, type -0.4.

6 In the **yw** text field, type 0.2.

Work Plane 1 (wp1) > Square 2 (sq2)

1 In the **Work Plane** toolbar, click  **Square**.

2 In the **Settings** window for **Square**, locate the **Size** section.

3 In the **Side length** text field, type 0.05.

4 Locate the **Position** section. From the **Base** list, choose **Center**.

5 In the **xw** text field, type -0.4.

6 In the **yw** text field, type -0.2.

Revolve 1 (rev1)

In the **Model Builder** window, under **Component 1 (comp1) > Geometry 1** right-click **Work Plane 1 (wp1)** and choose **Revolve**.

Sphere 1 (sph1)

1 In the **Geometry** toolbar, click  **Sphere**.

2 In the **Settings** window for **Sphere**, locate the **Size** section.

3 In the **Radius** text field, type 1.3.

4 Click to expand the **Layers** section. In the table, enter the following settings:

| Layer name | Thickness (m) |
|------------|---------------|
| Layer 1 | 0.3 |



5 Click  **Build All Objects**.

6 Click the  **Zoom Extents** button in the **Graphics** toolbar.

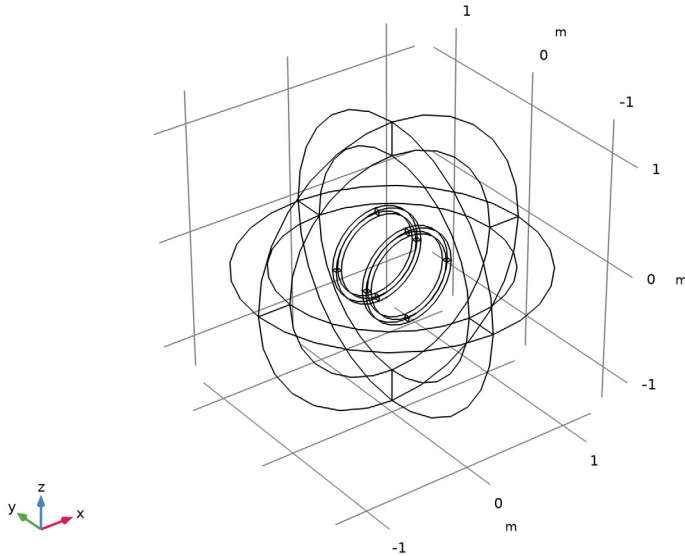
- The geometry is now complete. To see its interior, click the **Wireframe Rendering** button in the **Graphics** toolbar.



Line Segment 1 (ls1)

- In the **Geometry** toolbar, click  **More Primitives** and choose **Line Segment**.
- On the object **sph1**, select Point 4 only.
- In the **Settings** window for **Line Segment**, locate the **Endpoint** section.
- Click to select the  **Activate Selection** toggle button for **End vertex**.
- On the object **sph1**, select Point 9 only.

DEFINITIONS

Next, define the Infinite Element Domain.

Infinite Element Domain 1 (ie1)

- In the **Definitions** toolbar, click  **Infinite Element Domain**.
- In the **Settings** window for **Infinite Element Domain**, locate the **Geometry** section.
- From the **Type** list, choose **Spherical**.
- Select Domains 1–4 and 8–11 only.

Hide for Physics I

- 1 In the **Model Builder** window, right-click **View 1** and choose **Hide for Physics**.
- 2 In the **Settings** window for **Hide for Physics**, locate the **Geometric Entity Selection** section.
- 3 From the **Geometric entity level** list, choose **Boundary**.
- 4 Select Boundaries 6 and 10 only.

MAGNETIC FIELDS (MF)

Domain Coil I

- 1 In the **Physics** toolbar, click  **Domains** and choose **Domain Coil**.
- 2 Select Domain 6 only.
- 3 In the **Settings** window for **Domain Coil**, locate the **Coil** section.
- 4 From the **Conductor model** list, choose **Homogenized multiturn**.
- 5 From the **Coil type** list, choose **Circular**.
- 6 In the I_{coil} text field, type I0.
- 7 Locate the **Homogenized Conductor** section. From the **Coil wire cross-section area** list, choose **User defined**.
- 8 Find the **High-frequency effective loss** subsection. Clear the **Include harmonic loss** checkbox.

In order to specify the direction of the wires in the circular coil, use the **Coil Geometry** subfeature to select a group of edges forming a circle. The path of the wires will be automatically computed from the geometry of the selected edges. For the best results, the radius of the circular edges selected should be close to the average radius of the coil.

Coil Geometry I

- 1 In the **Model Builder** window, click **Coil Geometry 1**.
- 2 In the **Settings** window for **Coil Geometry**, locate the **Edge Selection** section.
- 3 Click  **Clear Selection**.

4 Select Edges 25, 26, 46, and 49 only.

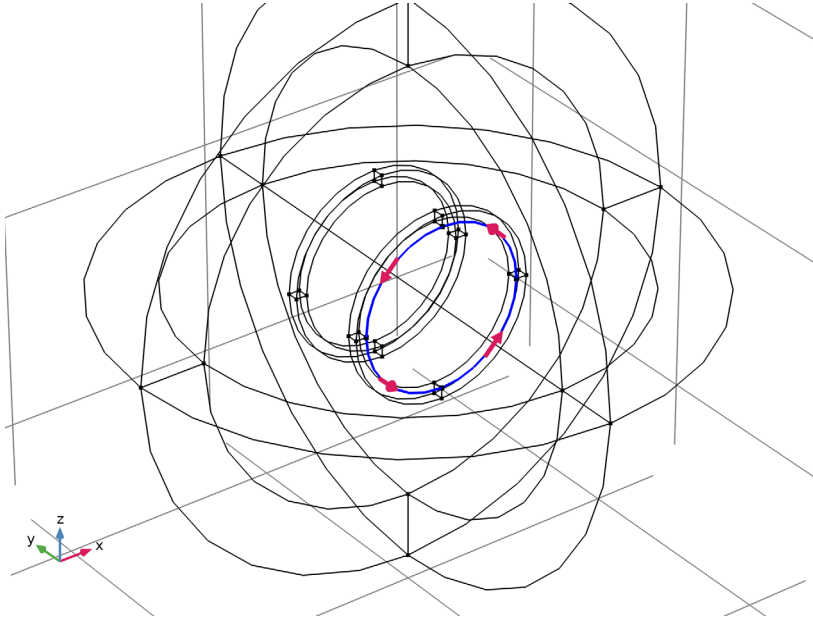

Now set up the second coil in the same way.

Domain Coil 2

- 1 In the **Physics** toolbar, click  **Domains** and choose **Domain Coil**.
- 2 Select Domain 7 only.
- 3 In the **Settings** window for **Domain Coil**, locate the **Coil** section.
- 4 From the **Conductor model** list, choose **Homogenized multiturn**.
- 5 From the **Coil type** list, choose **Circular**.
- 6 In the I_{coil} text field, type I0.
- 7 Locate the **Homogenized Conductor** section. From the **Coil wire cross-section area** list, choose **User defined**.
- 8 Find the **High-frequency effective loss** subsection. Clear the **Include harmonic loss** checkbox.

Coil Geometry 1

- 1 In the **Model Builder** window, click **Coil Geometry 1**.
- 2 In the **Settings** window for **Coil Geometry**, locate the **Edge Selection** section.
- 3 Click  **Clear Selection**.

4 Select Edges 30, 31, 72, and 75 only.

MAGNETIC FIELDS, CURRENTS ONLY (MFCO)

In the **Model Builder** window, under **Component 1 (comp1)** click **Magnetic Fields, Currents Only (mfco)**.

Conductor 1

1 In the **Physics** toolbar, click  **Domains** and choose **Conductor**.

2 Select Domain 6 only.

Terminal 1

1 In the **Model Builder** window, expand the **Conductor 1** node, then click **Terminal 1**.

2 Select Boundary 13 only.

3 In the **Settings** window for **Terminal**, locate the **Terminal** section.

4 In the I_0 text field, type $10 \cdot I_0$.

Conductor 2

1 In the **Physics** toolbar, click  **Domains** and choose **Conductor**.

2 Select Domain 7 only.

Terminal 1

1 In the **Model Builder** window, expand the **Conductor 2** node, then click **Terminal 1**.

2 Select Boundary 20 only.

3 In the **Settings** window for **Terminal**, locate the **Terminal** section.

4 In the I_0 text field, type $10 \cdot I_0$.

MATERIALS

Define the insulating material for the coils.

Coil Insulator

1 In the **Model Builder** window, under **Component 1 (comp1)** right-click **Materials** and choose **Blank Material**.

2 In the **Settings** window for **Material**, type Coil Insulator in the **Label** text field.

3 Select Domains 6 and 7 only.

4 Locate the **Material Contents** section. In the table, enter the following settings:

| Property | Variable | Value | Unit | Property group |
|-----------------------|--|-----------|------|----------------|
| Relative permeability | mur_iso ; murii = mur_iso, murij = 0 | 1 | | Basic |
| Relative permittivity | epsilon_r_iso ; epsilon_rii = epsilon_r_iso, epsilon_rij = 0 | 1 | | Basic |
| Electric conductivity | sigma_iso ; sigma_ii = sigma_iso, sigma_ij = 0 | 6e7 [S/m] | S/m | Basic |

MESH I

Next, set up the mesh.

Edge I

- 1 In the **Mesh** toolbar, click  **More Generators** and choose **Edge**.
- 2 Select Edge 40 only.

Distribution I

- 1 Right-click **Edge I** and choose **Distribution**.
- 2 In the **Settings** window for **Distribution**, locate the **Distribution** section.
- 3 In the **Number of elements** text field, type 50.

Free Tetrahedral I

- 1 In the **Mesh** toolbar, click  **Free Tetrahedral**.
- 2 In the **Settings** window for **Free Tetrahedral**, locate the **Domain Selection** section.
- 3 From the **Geometric entity level** list, choose **Domain**.
- 4 Select Domains 5–7 only.

Size I

- 1 Right-click **Free Tetrahedral I** and choose **Size**.
- 2 Select Domains 6 and 7 only.
- 3 In the **Settings** window for **Size**, locate the **Element Size** section.
- 4 Click the **Custom** button.

- 5 Locate the **Element Size Parameters** section.
- 6 Select the **Maximum element size** checkbox. In the associated text field, type 0.05.

Swept 1

In the **Mesh** toolbar, click  **Swept**.

Distribution 1

- 1 Right-click **Swept 1** and choose **Distribution**.
- 2 Right-click **Distribution 1** and choose **Build All**.

STUDY 1

Step 2: Stationary 2

In the **Study** toolbar, click  **Stationary**.

Step 1: Stationary

- 1 In the **Model Builder** window, click **Step 1: Stationary**.
- 2 In the **Settings** window for **Stationary**, locate the **Physics and Variables Selection** section.
- 3 In the **Solve for** column of the table, under **Component 1 (comp1)**, clear the checkbox for **Magnetic Fields, Currents Only (mfco)**.

Step 2: Stationary 2

- 1 In the **Model Builder** window, click **Step 2: Stationary 2**.
- 2 In the **Settings** window for **Stationary**, locate the **Physics and Variables Selection** section.
- 3 In the **Solve for** column of the table, under **Component 1 (comp1)**, clear the checkbox for **Magnetic Fields (mf)**.
- 4 In the **Model Builder** window, click **Study 1**.
- 5 In the **Settings** window for **Study**, locate the **Study Settings** section.
- 6 Clear the **Generate default plots** checkbox.
- 7 In the **Study** toolbar, click  **Compute**.

Add a selection to the computed dataset to exclude the outer boundaries.

DEFINITIONS

Coils

- 1 In the **Definitions** toolbar, click  **Explicit**.
- 2 Select Domains 6 and 7 only.
- 3 In the **Settings** window for **Explicit**, locate the **Output Entities** section.

- 4 From the **Output entities** list, choose **Adjacent boundaries**.
- 5 In the **Label** text field, type Coils.

Now add the plots.

RESULTS

In the **Model Builder** window, expand the **Results** node.

Study 1/Solution 1 (sol1)

In the **Model Builder** window, expand the **Results > Datasets** node, then click **Study 1/Solution 1 (sol1)**.

Selection

- 1 In the **Results** toolbar, click  **Attributes** and choose **Selection**.
- 2 In the **Settings** window for **Selection**, locate the **Geometric Entity Selection** section.
- 3 From the **Geometric entity level** list, choose **Boundary**.
- 4 From the **Selection** list, choose **Coils**.

Magnetic Flux Density, MF

- 1 In the **Results** toolbar, click  **3D Plot Group**.
- 2 In the **Settings** window for **3D Plot Group**, type Magnetic Flux Density, MF in the **Label** text field.

Slice 1

- 1 Right-click **Magnetic Flux Density, MF** and choose **Slice**.
- 2 In the **Settings** window for **Slice**, locate the **Plane Data** section.
- 3 From the **Plane** list, choose **xy-planes**.
- 4 In the **Planes** text field, type 1.
- 5 Click **Replace Expression** in the upper-right corner of the **Expression** section. From the menu, choose **Component 1 (comp1) > Magnetic Fields > Magnetic > mf.normB - Magnetic flux density norm - T**.
- 6 In the **Magnetic Flux Density, MF** toolbar, click  **Plot**.

Arrow Volume 1

- 1 In the **Model Builder** window, right-click **Magnetic Flux Density, MF** and choose **Arrow Volume**.
- 2 In the **Settings** window for **Arrow Volume**, click **Replace Expression** in the upper-right corner of the **Expression** section. From the menu, choose **Component 1 (comp1) > Magnetic Fields > Magnetic > mf.Hx,mf.Hy,mf.Hz - Magnetic field**.

- 3 Locate the **Arrow Positioning** section. Find the **x grid points** subsection. In the **Points** text field, type 24.
- 4 Find the **y grid points** subsection. In the **Points** text field, type 10.
- 5 Find the **z grid points** subsection. In the **Points** text field, type 1.
- 6 Locate the **Coloring and Style** section.
- 7 Select the **Scale factor** checkbox. In the associated text field, type 25.
- 8 In the **Magnetic Flux Density, MF** toolbar, click  **Plot**.

To make the coil look like a solid object, you can add a surface plot on its boundaries.

Surface 1

- 1 Right-click **Magnetic Flux Density, MF** and choose **Surface**.
- 2 In the **Settings** window for **Surface**, locate the **Expression** section.
- 3 In the **Expression** text field, type 1.
- 4 Locate the **Coloring and Style** section. From the **Coloring** list, choose **Uniform**.
- 5 From the **Color** list, choose **White**.

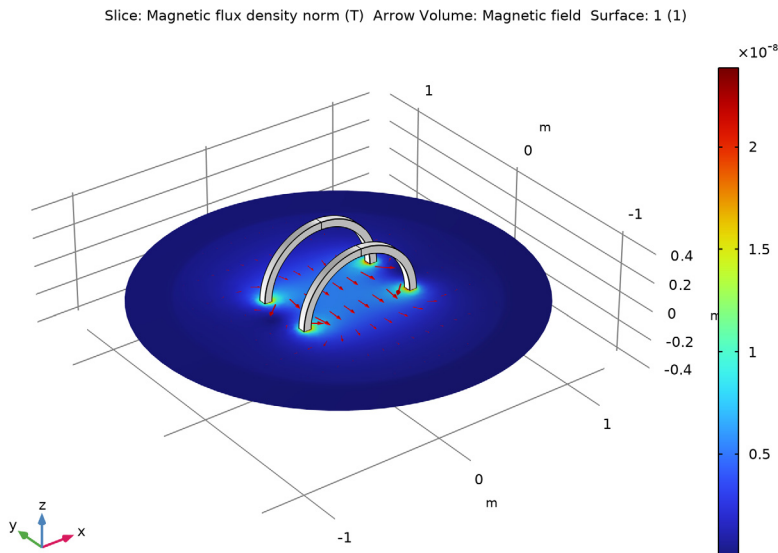

Next, compare the results of B_y and B_{yy} calculated from the two interfaces.

Comparison of By

- 1 In the **Results** toolbar, click  **ID Plot Group**.
- 2 In the **Settings** window for **ID Plot Group**, type Comparison of By in the **Label** text field.

Line Graph 1

- 1 Right-click **Comparison of By** and choose **Line Graph**.
- 2 Select Edge 40 only.
- 3 In the **Settings** window for **Line Graph**, locate the **y-Axis Data** section.
- 4 In the **Expression** text field, type mf.By.
- 5 Locate the **x-Axis Data** section. From the **Parameter** list, choose **Expression**.
- 6 In the **Expression** text field, type y.
- 7 Click to expand the **Coloring and Style** section. Find the **Line markers** subsection. From the **Marker** list, choose **Cycle**.
- 8 From the **Positioning** list, choose **Interpolated**.
- 9 Click to expand the **Legends** section. Select the **Show legends** checkbox.
- 10 From the **Legends** list, choose **Manual**.
- 11 In the table, enter the following settings:

| Legends |
|---------------------------|
| Magnetic Fields interface |

Line Graph 2

- 1 Right-click **Line Graph 1** and choose **Duplicate**.
- 2 In the **Settings** window for **Line Graph**, locate the **y-Axis Data** section.
- 3 In the **Expression** text field, type mf.co.By.
- 4 Click to expand the **Title** section. From the **Title type** list, choose **None**.
- 5 Locate the **Legends** section. In the table, enter the following settings:

| Legends |
|--|
| Magnetic Fields, Currents Only interface |

Comparison of By

- 1 In the **Model Builder** window, click **Comparison of By**.
- 2 In the **Settings** window for **ID Plot Group**, locate the **Legend** section.
- 3 From the **Position** list, choose **Upper middle**.

4 In the **Comparison of By** toolbar, click  **Plot**.

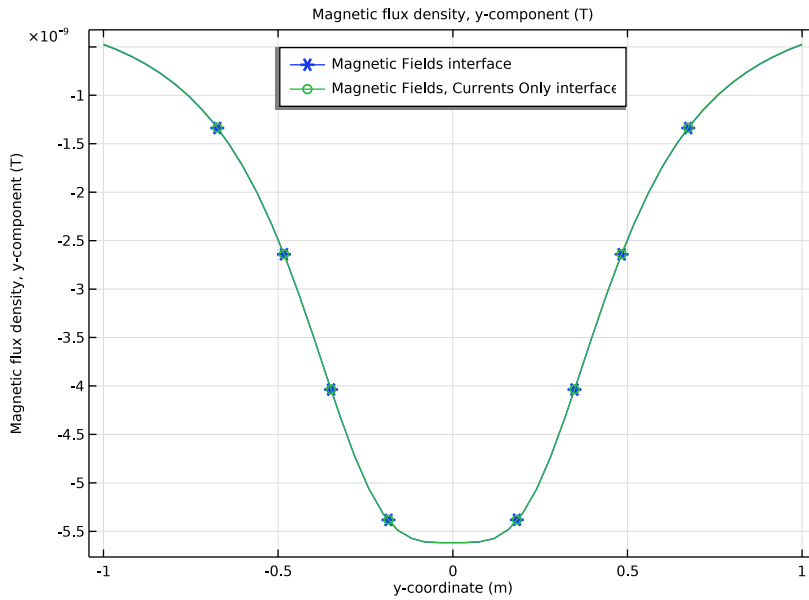

Comparison of Byy

- 1 Right-click **Comparison of By** and choose **Duplicate**.
- 2 In the **Model Builder** window, click **Comparison of By 1**.
- 3 In the **Settings** window for **ID Plot Group**, type Comparison of Byy in the **Label** text field.
- 4 Locate the **Legend** section. From the **Position** list, choose **Lower right**.

Line Graph 1

- 1 In the **Model Builder** window, click **Line Graph 1**.
- 2 In the **Settings** window for **Line Graph**, locate the **y-Axis Data** section.
- 3 In the **Expression** text field, type $d(\text{laginterp}(2, \text{mf} . \text{By}), y)$.

The mf interface is using Curl shape functions and the higher order spatial derivative is not available in postprocessing. In this case, use the laginterp operator.

Line Graph 2

- 1 In the **Model Builder** window, click **Line Graph 2**.
- 2 In the **Settings** window for **Line Graph**, locate the **y-Axis Data** section.

3 In the **Expression** text field, type `d(mf.co.By, y)`.

The `mf.co` interface is using secondary order Lagrange shape functions and the second derivative is available. The curves of `Byy` can be improved by using cubic elements.

4 In the **Comparison of Byy** toolbar, click  **Plot**.

