



Model created in COMSOL Multiphysics 6.4

# Generator in 2D

## *Introduction*

---

This example shows how the circular motion of a rotor with permanent magnets generates an induced EMF in a stator winding. The generated voltage is calculated as a function of time during the rotation. The model also shows the influence on the voltage from material parameters, rotation velocity, and number of turns in the winding.

The center of the rotor consists of annealed medium carbon steel, which is a material with a high relative permeability. The center is surrounded with several blocks of a permanent magnet made of sintered NdFeB, creating a strong magnetic field. The stator is made of the same permeable material as the center of the rotor, confining the field in closed loops through the winding. The winding is wound around the stator poles. [Figure 1](#) shows the generator with part of the stator sliced in order to show the winding and the rotor.

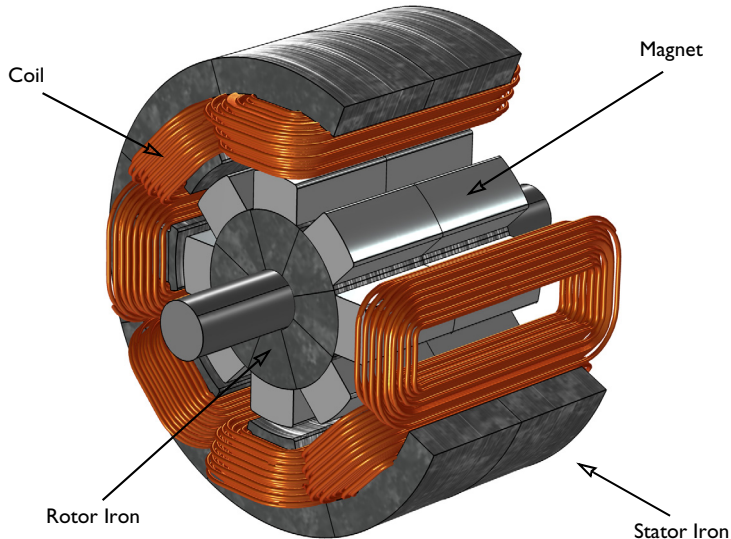

*Figure 1: Drawing of a generator showing how the rotor, stator, and stator winding are constructed. The coils are connected in series in order to give the highest possible voltage.*

The COMSOL Multiphysics model of the generator is a time-dependent 2D problem on a cross section through the generator. This is a true time-dependent model where the motion of the magnetic sources in the rotor is accounted for in the boundary condition between the stator and rotor geometries. Thus, there is no Lorentz term in the equation, resulting in the PDE

$$\sigma \frac{\partial \mathbf{A}}{\partial t} + \nabla \times \left( \frac{1}{\mu} \nabla \times \mathbf{A} \right) = 0$$

where the magnetic vector potential only has a  $z$  component.

Rotation is modeled using a ready-made physics interface for rotating machinery. The center part of the geometry, containing the rotor and part of the air-gap, rotates relative to the coordinate system of the stator. The rotor and the stator are built as two separate geometry objects, so it is possible to use an assembly (see *Finalizing the Geometry* in the *COMSOL Multiphysics Reference Manual* for details). This has several advantages: the coupling between the rotor and the stator is done automatically, the parts are meshed independently, and it allows for a discontinuity in the vector potential at the interface between the two geometry objects (called slits). The rotor problem is solved in a rotating coordinate system where the rotor is fixed (the rotor frame), whereas the stator problem is solved in a coordinate system that is fixed with respect to the stator (the stator frame). An identity pair connecting the rotating rotor frame with the fixed stator frame is created between the rotor and the stator. The identity pair enforces continuity for the vector potential in the global fixed coordinate system (the stator frame).

The stator and center of the rotor are made of annealed medium-carbon steel (soft iron), which is implemented in COMSOL Multiphysics as an interpolation function of the B-H curve of the material; see [Figure 2](#).

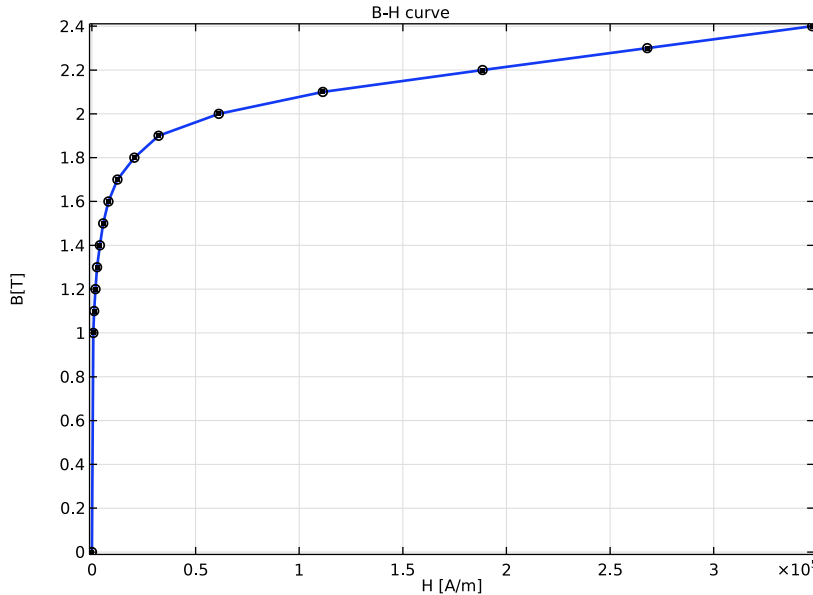

*Figure 2: The norm of the magnetic flux,  $|\mathbf{B}|$ , versus the norm of the magnetic field,  $|\mathbf{H}|$ , for the rotor and stator materials.*

The generated voltage is computed automatically with the use of the Coil feature. In this simplified example all coils are connected in series, making out a single stator winding. The series connection of coils is realized in COMSOL Multiphysics by adding coil domains to a Coil group. In this way, the output voltage is the sum of voltages generated by each coil even though they are not geometrically connected in the 2D model.

The resistive and iron losses are computed with the use of a Loss Calculation subfeature and a Time to Frequency Losses study. In this 2D model, the magnets are modeled by using the Coil feature, which allows for the calculation of induced currents and resistive losses. The settings impose a zero net perpendicular current in each of the magnets by activating the Coil group checkbox. For the iron part of the generator, the Bertotti loss model is selected to compute the cycle averaged loss power density. A surface integration is then made to compute the total loss power of the generator. The generated voltage and the losses are compared with the 3D counterpart of this model, that is, [Modeling of an Electric Generator in 3D](#).

## Results and Discussion

---

The generated voltage in the rotor winding is close to a sinusoidal signal. At a rotation speed of 60 rpm the voltage has an amplitude of 700 V in total; see [Figure 3](#).

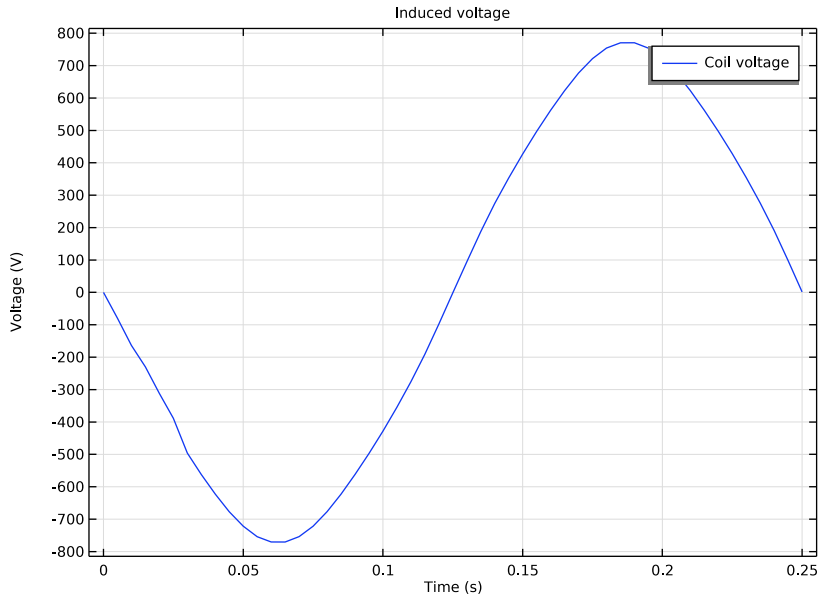

*Figure 3: The generated voltage over one quarter of a revolution. This simulation used a 100-turn winding.*

The norm of the magnetic flux density,  $|\mathbf{B}|$ , and the  $\mathbf{B}$  field lines are shown below in [Figure 4](#) at the time 0.20 s.

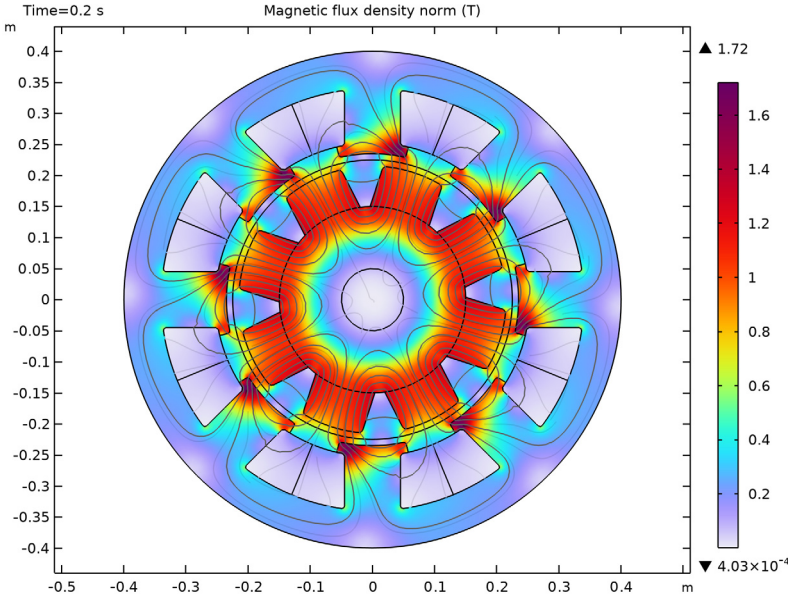

*Figure 4: The norm and the field lines of the magnetic flux density after 0.2 s of rotation. Note the darker regions, which indicate the position of the permanent magnets in the rotor.*

The cycle averaged losses power density is shown below in [Figure 5](#).

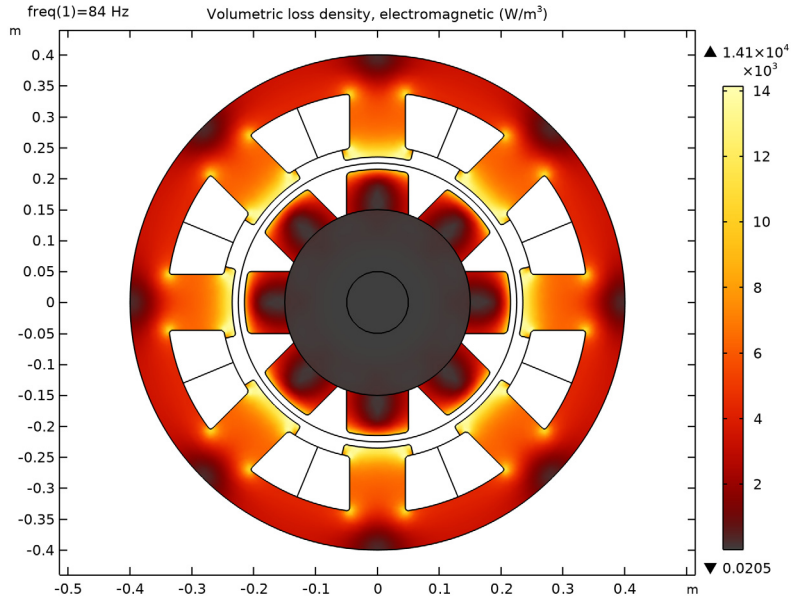

*Figure 5: The volumetric loss density of the generator.*

---

**Application Library path:** ACDC\_Module/Devices,\_Motors\_and\_Generators/  
generator\_2d

---

### *Modeling Instructions*

---

From the **File** menu, choose **New**.



#### **NEW**

In the **New** window, click  **Model Wizard**.

#### **MODEL WIZARD**

**1** In the **Model Wizard** window, click  **2D**.

**2** In the **Select Physics** tree, select **AC/DC > Electromagnetics and Mechanics > Rotating Machinery, Magnetic (rmm)**.

- 3 Click **Add**.
- 4 Click  **Study**.
- 5 In the **Select Study** tree, select **General Studies > Stationary**.
- 6 Click  **Done**.

## GLOBAL DEFINITIONS



### Parameters 1

- 1 In the **Model Builder** window, under **Global Definitions** click **Parameters 1**.
- 2 In the **Settings** window for **Parameters**, locate the **Parameters** section.
- 3 In the table, enter the following settings:



Name	Expression	Value	Description
L	0.4[m]	0.4 m	Length of generator
rpm	60[1/min]	1 l/s	Rotational speed of rotor
d_wire	3[mm]	0.003 m	Diameter of wire in the winding
N	100	100	Number of turns in the winding

Next, build the generator using rotor and stator parts from the geometry part library. Initialize the parts, and tick the selections that are predefined to make it convenient to assign material properties and magnetization direction.

## PART LIBRARIES

- 1 In the **Home** toolbar, click  **Windows** and choose **Part Libraries**.
- 2 In the **Part Libraries** window, select **AC/DC Module > Rotating Machinery 2D > Rotors > Internal > surface\_mounted\_magnet\_internal\_rotor\_2d** in the tree.
- 3 Click  **Add to Geometry**.

## PART LIBRARIES

- 1 In the **Home** toolbar, click  **Windows** and choose **Part Libraries**.
- 2 In the **Model Builder** window, under **Component 1 (comp1)** click **Geometry 1**.
- 3 In the **Part Libraries** window, select **AC/DC Module > Rotating Machinery 2D > Stators > External > slotted\_external\_stator\_2d** in the tree.
- 4 Click  **Add to Geometry**.

## GEOMETRY 1

- 1 In the **Home** toolbar, click  **Build All**.

2 Click the  **Zoom Extents** button in the **Graphics** toolbar.

3 In the **Model Builder** window, under **Component 1 (comp1)** click **Geometry 1**.

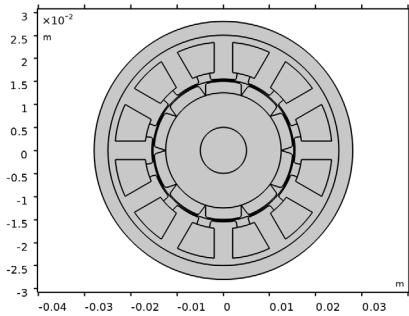

*Internal Rotor – Surface Mounted Magnets 1 (pi1)*

1 In the **Model Builder** window, under **Component 1 (comp1)** > **Geometry 1** click

**Internal Rotor – Surface Mounted Magnets 1 (pi1)**.

2 In the **Settings** window for **Part Instance**, locate the **Input Parameters** section.

3 In the table, enter the following settings:

Name	Expression	Value	Description
number_of_poles	8	8	Number of magnetic poles in rotor
number_of_modeled_poles	8	8	Number of magnetic poles included in the geometry
shaft_diam	10 [cm]	0.1 m	Diameter of the shaft
rotor_diam	30 [cm]+2*6.5 [cm]	0.43 m	Diameter of the rotor
cont_diam	0.45 [m]	0.45 m	Diameter of the stator-rotor continuity interface
magnet_h	6.5 [cm]	0.065 m	Height of the magnets
magnet_w	10 [cm]	0.1 m	Width of the magnets (set to 0 to use all available space)
magnet_fillet_size	0.6 [cm]	0.006 m	Radius of magnet fillet

4 Click to expand the **Domain Selections** section. In the table, enter the following settings:

Name	Keep	Physics	Contribute to
Shaft	√	√	None
Rotor iron	√	√	None
Odd magnets	√	√	None
Even magnets	√	√	None
Rotor magnets	√	√	None
Rotor solid domains	√	√	None
Rotor air	√	√	None
All	√	√	None

*External Stator – Slotted I (pi2)*

1 In the **Model Builder** window, click **External Stator – Slotted I (pi2)**.

2 In the **Settings** window for **Part Instance**, locate the **Input Parameters** section.

3 In the table, enter the following settings:

Name	Expression	Value	Description
number_of_slots	8	8	Number of slots in stator
number_of_modeled_slots	8	8	Number of slots included in the geometry
backiron_th	6 [cm]	0.06 m	Thickness of back-iron
stator_diam	80 [cm]	0.8 m	Diameter of the stator
external_air_size	0 [cm]	0 m	Size of air external to stator
cont_diam	45 [cm]	0.45 m	Diameter of the stator-rotor continuity interface
shoe_h	1.75 [cm]	0.0175 m	Height of the shoe
shoe_w	11.5 [cm]	0.115 m	Width of the shoe
tooth_h	10.5 [cm]	0.105 m	Height of the tooth
tooth_w	9 [cm]	0.09 m	Width of the tooth
shoe_fillet_size	0.4 [cm]	0.004 m	Radius of the shoe fillet
slot_outer_fillet_size	0.4 [cm]	0.004 m	Radius of the outer slot fillet



Name	Expression	Value	Description
slot_inner_fillet_size	0.4 [cm]	0.004 m	Radius of the inner slot fillet
slot_winding_type	2	2	Slot winding type: 1-No partition, 2-Radial partition, 3-Azimuthal partition, 4-Radial and azimuthal partition.

4 Locate the **Domain Selections** section. In the table, enter the following settings:



Name	Keep	Physics	Contribute to
Stator iron	√	√	None
Stator slots	√	√	None
Stator air	√	√	None
All	√	√	None

## DEFINITIONS

### *Iron*

- 1 In the **Definitions** toolbar, click  **Union**.
- 2 In the **Settings** window for **Union**, locate the **Input Entities** section.
- 3 Under **Selections to add**, click  **Add**.
- 4 In the **Add** dialog, in the **Selections to add** list, choose **Shaft (Internal Rotor – Surface Mounted Magnets I)**, **Rotor iron (Internal Rotor – Surface Mounted Magnets I)**, and **Stator iron (External Stator – Slotted I)**.
- 5 Click **OK**.
- 6 In the **Settings** window for **Union**, type **Iron** in the **Label** text field.



### *Iron and Magnets*

- 1 In the **Definitions** toolbar, click  **Union**.
- 2 In the **Settings** window for **Union**, locate the **Input Entities** section.
- 3 Under **Selections to add**, click  **Add**.
- 4 In the **Add** dialog, in the **Selections to add** list, choose **Iron** and **Rotor Magnets (Internal Rotor – Surface Mounted Magnets I)**.
- 5 Click **OK**.
- 6 In the **Settings** window for **Union**, type **Iron** and **Magnets** in the **Label** text field.

Create an assembly from the two geometry objects, connected by a pair boundary.



## GEOMETRY I

### *Form Union (fin)*

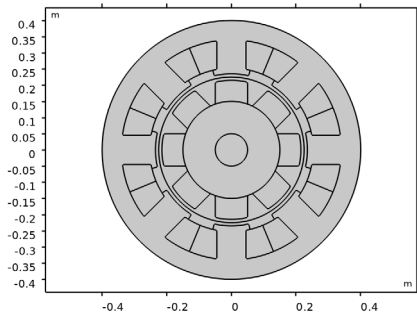
- 1 In the **Model Builder** window, under **Component 1 (comp1) > Geometry 1** click **Form Union (fin)**.
- 2 In the **Settings** window for **Form Union/Assembly**, locate the **Form Union/Assembly** section.
- 3 From the **Action** list, choose **Form an assembly**.
- 4 In the **Geometry** toolbar, click  **Build All**.
- 5 Click the  **Zoom Extents** button in the **Graphics** toolbar.
- 6 In the **Model Builder** window, click **Geometry 1**.



## ADD MATERIAL

- 1 In the **Materials** toolbar, click  **Add Material** to open the **Add Material** window.
- 2 Go to the **Add Material** window.
- 3 In the tree, select **Built-in > Air**.
- 4 Click the **Add to Component** button in the window toolbar.
- 5 In the tree, select **AC/DC > Soft Iron (Without Losses)**.
- 6 Click the **Add to Component** button in the window toolbar.
- 7 In the tree, select **AC/DC > Hard Magnetic Materials > Sintered NdFeB Grades (Chinese Standard) > N50 (Sintered NdFeB)**.
- 8 Click the **Add to Component** button in the window toolbar.
- 9 In the **Materials** toolbar, click  **Add Material** to close the **Add Material** window.

## MATERIALS

### *Soft Iron (Without Losses) (mat2)*

- 1 In the **Settings** window for **Material**, locate the **Geometric Entity Selection** section.

2 From the **Selection** list, choose **Iron**.

*N50 (Sintered NdFeB) (mat3)*

1 In the **Model Builder** window, click **N50 (Sintered NdFeB) (mat3)**.

2 In the **Settings** window for **Material**, locate the **Geometric Entity Selection** section.

3 From the **Selection** list, choose **Rotor Magnets (Internal Rotor – Surface Mounted Magnets 1)**.

#### **ROTATING MACHINERY, MAGNETIC (RMM)**

1 In the **Model Builder** window, under **Component 1 (comp1)** click **Rotating Machinery, Magnetic (rmm)**.

2 In the **Settings** window for **Rotating Machinery, Magnetic**, locate the **Thickness** section.

3 In the *d* text field, type L.

Next, use a Rotating Domain feature to specify the rotor's rotational velocity.

#### **COMPONENT 1 (COMP1)**

*Rotating Domain 1*

1 In the **Physics** toolbar, click  **Moving Mesh** and choose **Rotating Domain**.

2 In the **Settings** window for **Rotating Domain**, locate the **Domain Selection** section.

3 From the **Selection** list, choose **All domains (Internal Rotor – Surface Mounted Magnets 1)**.

4 Locate the **Rotation** section. From the **Rotation type** list, choose **Specified rotational velocity**.

5 From the **Rotational velocity expression** list, choose **Constant revolutions per time**.

6 In the *f* text field, type rpm.

To define the remanent flux direction of all magnets, use the Conducting Magnet feature.

#### **ROTATING MACHINERY, MAGNETIC (RMM)**

*Conducting Magnet 1*

1 In the **Physics** toolbar, click  **Domains** and choose **Conducting Magnet**.

2 In the **Settings** window for **Conducting Magnet**, locate the **Domain Selection** section.

3 From the **Selection** list, choose **Rotor Magnets (Internal Rotor – Surface Mounted Magnets 1)**.

4 Locate the **Magnet** section. From the **Pattern type** list, choose **Circular pattern**.

5 From the **Type of periodicity** list, choose **Alternating**.

### *North I*

- 1 In the **Model Builder** window, click **North I**.
- 2 Select Boundary 212 only.

### *South I*

- 1 In the **Model Builder** window, click **South I**.
- 2 Select Boundary 218 only.

### *Conducting Magnet I*

In the **Model Builder** window, click **Conducting Magnet I**.

### *Loss Calculation I*

In the **Physics** toolbar, click  **Attributes** and choose **Loss Calculation**.

### *Iron*

- 1 In the **Physics** toolbar, click  **Domains** and choose **Ampère's Law**.
- 2 In the **Settings** window for **Ampère's Law**, locate the **Constitutive Relation B-H** section.
- 3 From the **Magnetization model** list, choose **B-H curve**.
- 4 Locate the **Domain Selection** section. From the **Selection** list, choose **Iron**.
- 5 In the **Label** text field, type Iron.

Add the **Loss Calculation** subfeature to compute iron losses.

### *Loss Calculation I*

1 In the **Physics** toolbar, click  **Attributes** and choose **Loss Calculation**.

Set loss model to **Bertotti**.

- 2 In the **Settings** window for **Loss Calculation**, locate the **Loss Model** section.
- 3 From the **Loss model** list, choose **Bertotti**.

### *Domain Coil I*

- 1 In the **Physics** toolbar, click  **Domains** and choose **Domain Coil**.
- 2 In the **Settings** window for **Domain Coil**, locate the **Domain Selection** section.
- 3 From the **Selection** list, choose **Stator slots (External Stator – Slotted I)**.
- 4 Locate the **Coil** section. From the **Conductor model** list, choose **Homogenized multiturn**.
- 5 In the  $I_{\text{coil}}$  text field, type 0[A].
- 6 Locate the **Homogenized Conductor** section. In the  $N$  text field, type N.
- 7 From the **Coil wire cross-section area** list, choose **From diameter**.
- 8 In the  $d$  text field, type d\_wire.

- 9 Locate the **Coil** section. Select the **Coil group** checkbox.

#### *Reversed Current Direction*

- 1 In the **Physics** toolbar, click  **Attributes** and choose **Reversed Current Direction**.
- 2 Select Domains 1, 4, 8, 10, 11, 13, 16, and 18 only.

### **STUDY 1**



#### *Step 2: Time Dependent*

- 1 In the **Study** toolbar, click  **Time Dependent**.
- 2 In the **Settings** window for **Time Dependent**, locate the **Study Settings** section.
- 3 In the **Output times** text field, type range (0, 0.005, 0.25).



Before solving refine the mesh on boundaries associated with the **Continuity** condition for more accurate results.

### **DEFINITIONS**

#### *Identity Boundary Pair 1 (ap1)*

- 1 In the **Model Builder** window, under **Component 1 (comp1) > Definitions** click **Identity Boundary Pair 1 (ap1)**.
- 2 In the **Settings** window for **Pair**, locate the **Source Boundaries** section.
- 3 Click  **Create Selection**.
- 4 In the **Create Selection** dialog, type source in the **Selection name** text field.
- 5 Click **OK**.
- 6 In the **Settings** window for **Pair**, locate the **Destination Boundaries** section.
- 7 Click  **Create Selection**.
- 8 In the **Create Selection** dialog, type destination in the **Selection name** text field.
- 9 Click **OK**.

#### *Airgap Boundaries*

- 1 In the **Definitions** toolbar, click  **Union**.
- 2 In the **Settings** window for **Union**, type Airgap Boundaries in the **Label** text field.
- 3 Locate the **Geometric Entity Level** section. From the **Level** list, choose **Boundary**.
- 4 Locate the **Input Entities** section. Under **Selections to add**, click  **Add**.
- 5 In the **Add** dialog, in the **Selections to add** list, choose **source** and **destination**.
- 6 Click **OK**.

## MESH I

### *Free Triangular I*

In the **Mesh** toolbar, click  **Free Triangular**.

### *Size*

- 1 In the **Model Builder** window, click **Size**.
- 2 In the **Settings** window for **Size**, locate the **Element Size** section.
- 3 From the **Predefined** list, choose **Coarser**.
- 4 Click the **Custom** button.
- 5 Locate the **Element Size Parameters** section. In the **Maximum element size** text field, type 0.015.

### *Size I*

- 1 In the **Model Builder** window, right-click **Free Triangular I** and choose **Size**.
- 2 In the **Settings** window for **Size**, locate the **Geometric Entity Selection** section.
- 3 From the **Geometric entity level** list, choose **Boundary**.
- 4 From the **Selection** list, choose **Airgap Boundaries**.
- 5 Locate the **Element Size** section. From the **Predefined** list, choose **Extremely fine**.
- 6 Click  **Build All**.

## STUDY I

In the **Study** toolbar, click  **Compute**.

### *Postprocessing the Results*

---

Now, plot the solution in the spatial frame (the stator's fixed frame) at the time  $t = 0.2$  s.

- 1 In the **Settings** window for **2D Plot Group**, locate the **Data** section.
- 2 From the **Time (s)** list, choose **0.2**.
- 3 In the **Magnetic Flux Density (rmm)** toolbar, click  **Plot**.

[Figure 4](#) shows the rotor position at  $t = 0.2$  s, as well as the magnetic flux density norm and magnetic flux density lines. Next, plot the induced EMF in a quarter of the cycle.

### *Induced Coil Voltage*

- 1 In the **Results** toolbar, click  **ID Plot Group**.
- 2 In the **Settings** window for **ID Plot Group**, type Induced Coil Voltage in the **Label** text field.

- 3 Click to expand the **Title** section. From the **Title type** list, choose **Manual**.
- 4 In the **Title** text area, type Induced voltage.
- 5 Locate the **Plot Settings** section.
- 6 Select the **x-axis label** checkbox. In the associated text field, type Time (s).
- 7 Select the **y-axis label** checkbox. In the associated text field, type Voltage (V).

#### *Global 1*



- 1 Right-click **Induced Coil Voltage** and choose **Global**.
- 2 In the **Settings** window for **Global**, click **Replace Expression** in the upper-right corner of the **y-Axis Data** section. From the menu, choose **Component 1 (comp1) > Rotating Machinery, Magnetic (Magnetic Fields) > Coil parameters > rmm.VCoil\_I - Coil voltage - V**.

- 3 In the **Induced Coil Voltage** toolbar, click  **Plot**.

The resulting plot is [Figure 3](#).

Next, add the **Time to Frequency Losses** study to compute the iron loss.

#### **ADD STUDY**

- 1 In the **Home** toolbar, click  **Add Study** to open the **Add Study** window.
- 2 Go to the **Add Study** window.
- 3 Find the **Studies** subsection. In the **Select Study** tree, select **Preset Studies for Selected Physics Interfaces > Time-to-Frequency Losses**.
- 4 Click the **Add Study** button in the window toolbar.
- 5 In the **Home** toolbar, click  **Add Study** to close the **Add Study** window.

#### **STUDY 2**

##### *Step 1: Time-to-Frequency Losses*

- 1 In the **Settings** window for **Time-to-Frequency Losses**, locate the **Study Settings** section.
- 2 From the **Input study** list, choose **Study 1, Time Dependent**.
- 3 In the **Electrical period** text field, type 0.25.
- 4 In the **Study** toolbar, click  **Compute**.

#### **RESULTS**

##### *Cycle Averaged Losses (rmm)*

The resulting plot is [Figure 5](#).

Finally, compute the total iron loss power.

*Surface Integration I*

- 1 In the **Results** toolbar, click  **More Derived Values** and choose **Integration > Surface Integration**.
- 2 In the **Settings** window for **Surface Integration**, locate the **Data** section.
- 3 From the **Dataset** list, choose **Study 2/Solution 3 (sol3)**.
- 4 Locate the **Selection** section. From the **Selection** list, choose **Iron and Magnets**.
- 5 Click **Replace Expression** in the upper-right corner of the **Expressions** section. From the menu, choose **Component I (comp1) > Rotating Machinery, Magnetic (Magnetic Fields, No Currents) > Heating and losses > rmm.Qh - Volumetric loss density, electromagnetic - W/m³**.
- 6 Locate the **Expressions** section. In the table, enter the following settings:

Expression	Unit	Description
rmm.Qh*L	W	Total loss power

- 7 Click  **Evaluate**.

The computed total loss power is about 455 W.