



Model created in COMSOL Multiphysics 6.4

Dielectric Shielding Comparison

Introduction

The dielectric shielding boundary condition is meant to approximate a thin layer of material with high relative permittivity compared to its surroundings, and is available for electrostatic field modeling. This example compares the dielectric shielding boundary condition to a full-fidelity model and discusses the range of applicability of this boundary condition.

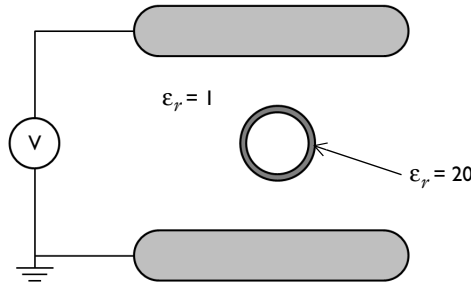

Figure 1: A two-dimensional parallel plate capacitor in free space. A thin-walled circular inclusion between the plates distorts the electric field.

Model Definition

The situation being modeled is shown in [Figure 1](#). Two parallel plates in free space (relative permittivity $\epsilon_r = 1$) have a voltage difference applied to them, forming a capacitor. Between these plates there is a circular inclusion with an outer diameter of 1 cm and a wall thickness of 1 mm. The walls are made of a high dielectric ($\epsilon_r = 20$) material.

The walls of this inclusion are modeled in two ways. First, by using a full fidelity model that includes the thickness of the walls. Then, by using the dielectric shielding boundary condition instead. The inside of the inclusion has the same properties as free space. The two models are separate, but are being modeled simultaneously for comparison.

The location of the dielectric shielding condition is at the centerline, midway between the inner and outer radii of the full fidelity model. Note that, when using the dielectric shielding condition, the total volume of the surrounding material is slightly larger, since the thickness of the wall is not being explicitly modeled.

Results and Discussion

The electric field and isolines of the voltage are plotted in [Figure 2](#). The field lines can be observed to deform toward the inclusion. It can be seen that the solution for the electric shielding model agrees well with that of the full fidelity model.

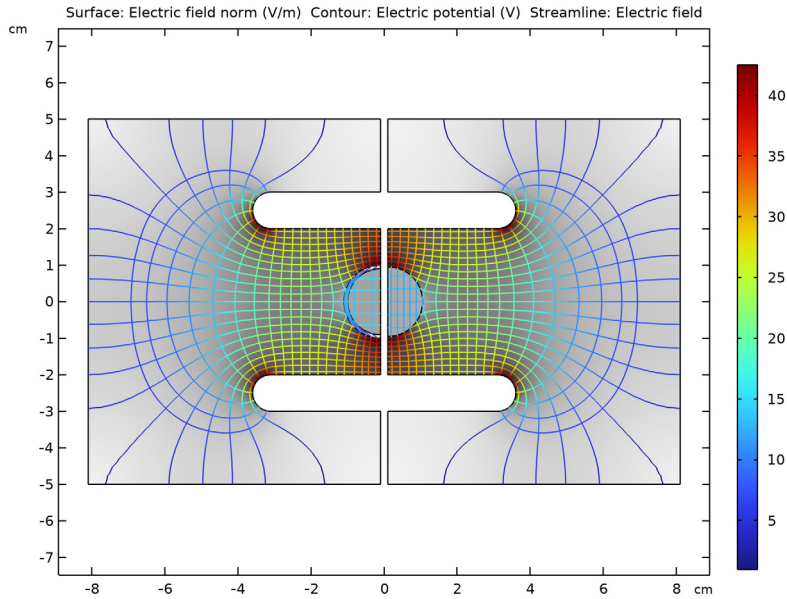

Figure 2: Isolines of the voltage field and streamlines of the electric field are plotted. The lines are colored according to the strength of the electric field, and the background gray-scale plot is of the electric field norm. The full fidelity (left) and dielectric shielding (right) solutions are almost identical.

The dielectric shielding boundary condition can be used in cases where the thickness of the boundary being approximated is much smaller than the characteristic size of the model domain, and when the relative permittivity of the layer is greater than the surrounding medium. When this boundary condition can be used, the resulting mesh size is much smaller, saving solution time and memory.

Application Library path: ACDC_Module/Introductory_Electrostatics/
dielectric_shielding_comparison



Modeling Instructions

From the **File** menu, choose **New**.

NEW

In the **New** window, click  **Model Wizard**.

MODEL WIZARD

- 1 In the **Model Wizard** window, click  **2D**.
- 2 In the **Select Physics** tree, select **AC/DC** > **Electric Fields and Currents** > **Electrostatics (es)**.
- 3 Click **Add**.
- 4 Click  **Study**.
- 5 In the **Select Study** tree, select **General Studies** > **Stationary**.
- 6 Click  **Done**.

GEOMETRY I

- 1 In the **Model Builder** window, under **Component 1 (comp1)** click **Geometry 1**.
- 2 In the **Settings** window for **Geometry**, locate the **Units** section.
- 3 From the **Length unit** list, choose **cm**.

GLOBAL DEFINITIONS

Parameters 1

- 1 In the **Model Builder** window, under **Global Definitions** click **Parameters 1**.
- 2 In the **Settings** window for **Parameters**, locate the **Parameters** section.
- 3 In the table, enter the following settings:

Name	Expression	Value	Description
er_b	20	20	Relative permittivity, dielectric
V0	1[V]	1 V	Applied voltage

GEOMETRY I

Rectangle 1 (r1)

- 1 In the **Geometry** toolbar, click  **Rectangle**.
- 2 In the **Settings** window for **Rectangle**, locate the **Size and Shape** section.
- 3 In the **Width** text field, type 8.

- 4 In the **Height** text field, type 10.
- 5 Locate the **Position** section. In the **x** text field, type 0.1.
- 6 In the **y** text field, type -5.

Rectangle 2 (r2)

- 1 In the **Geometry** toolbar, click  **Rectangle**.
- 2 In the **Settings** window for **Rectangle**, locate the **Size and Shape** section.
- 3 In the **Width** text field, type 3.5.
- 4 Locate the **Position** section. In the **x** text field, type 0.1.
- 5 In the **y** text field, type 2.

Fillet 1 (fil1)

- 1 In the **Geometry** toolbar, click  **Fillet**.
- 2 On the object **r2**, select Points 2 and 3 only.

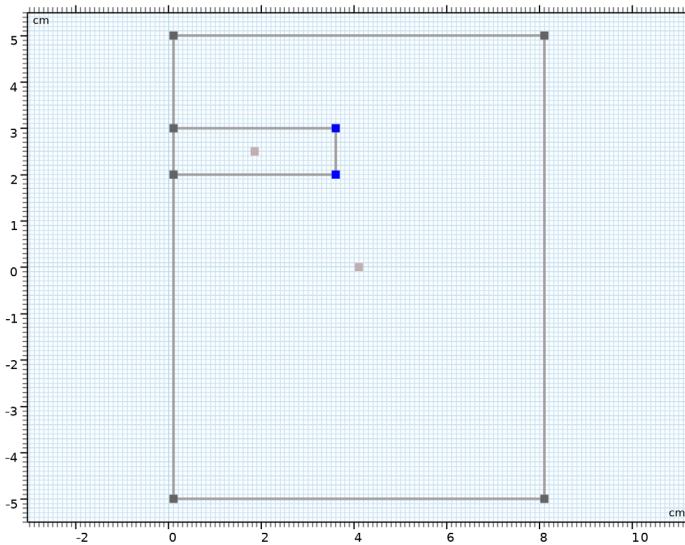



- 3 In the **Settings** window for **Fillet**, locate the **Radius** section.
- 4 In the **Radius** text field, type 0.5.

Copy 1 (copy1)

- 1 In the **Geometry** toolbar, click  **Transforms** and choose **Copy**.
- 2 Select the object **fill** only.
- 3 In the **Settings** window for **Copy**, locate the **Displacement** section.

4 In the **y** text field, type -5.

Mirror 1 (mir1)

- 1 In the **Geometry** toolbar, click  **Transforms** and choose **Mirror**.
- 2 Click in the **Graphics** window and then press Ctrl+A to select all objects.
- 3 In the **Settings** window for **Mirror**, locate the **Input** section.
- 4 Select the **Keep input objects** checkbox.
- 5 Click  **Build Selected**.
- 6 Click the  **Zoom Extents** button in the **Graphics** toolbar.

Circle 1 (c1)

- 1 In the **Geometry** toolbar, click  **Circle**.
- 2 In the **Settings** window for **Circle**, locate the **Size and Shape** section.
- 3 In the **Radius** text field, type 0.95.
- 4 In the **Sector angle** text field, type 180.
- 5 Locate the **Position** section. In the **x** text field, type 0.1.
- 6 Locate the **Rotation Angle** section. In the **Rotation** text field, type -90.

Circle 2 (c2)

- 1 In the **Geometry** toolbar, click  **Circle**.
- 2 In the **Settings** window for **Circle**, locate the **Size and Shape** section.
- 3 In the **Sector angle** text field, type 180.
- 4 Locate the **Position** section. In the **x** text field, type -0.1.
- 5 Locate the **Rotation Angle** section. In the **Rotation** text field, type 90.
- 6 Click to expand the **Layers** section. In the table, enter the following settings:

Layer name	Thickness (cm)
Layer 1	1 [mm]

7 Click  **Build All Objects.**

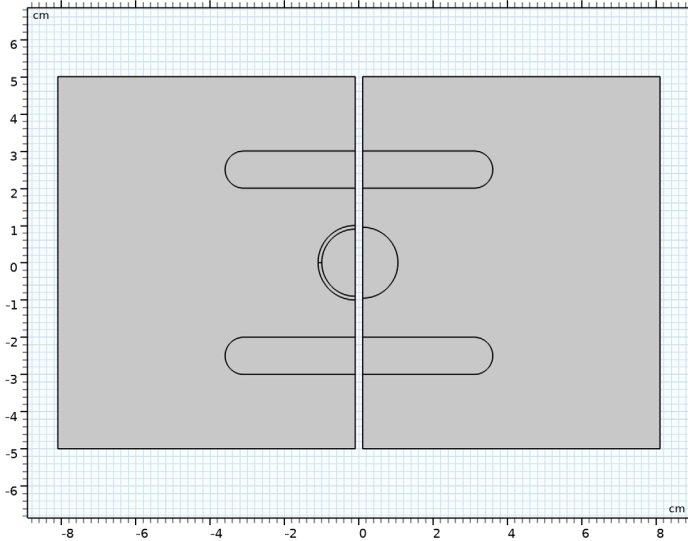

The geometry on the left side describes the full fidelity model. The geometry on the right side replaces the thin layer with a boundary in order to use the **Dielectric Shielding** feature.

DEFINITIONS

Create a set of selections to use when setting up the physics. First, create a selection for the wall of the inclusion in the full fidelity model.

Full fidelity

1 In the **Definitions** toolbar, click  **Explicit.**

2 Select Domains 4 and 5 only.

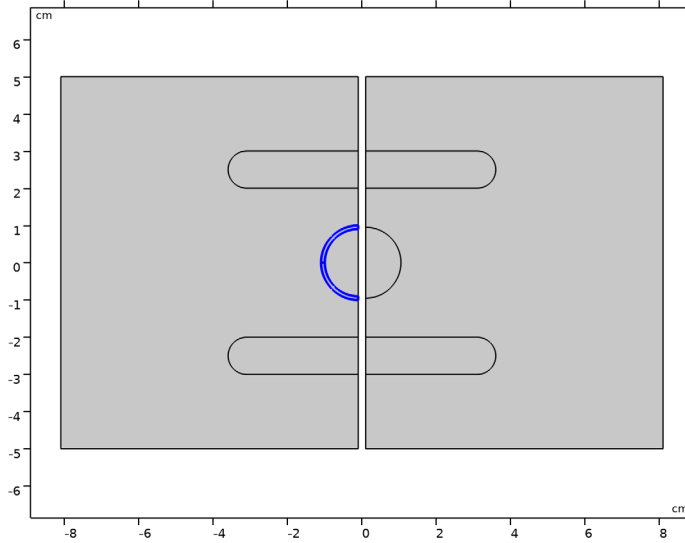

3 In the **Settings** window for **Explicit**, type Full fidelity in the **Label** text field. Add a selection for the dielectric shielding boundaries.

Dielectric shielding

- 1 In the **Definitions** toolbar, click  **Explicit**.
- 2 In the **Settings** window for **Explicit**, locate the **Input Entities** section.
- 3 From the **Geometric entity level** list, choose **Boundary**.

4 Select Boundaries 42 and 43 only.

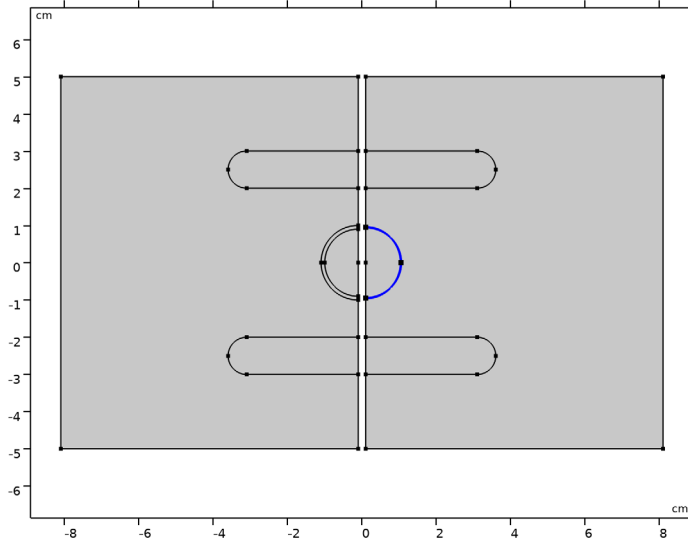

5 In the **Label** text field, type **Dielectric shielding**.

Add a selection for the bulk area. This is the modeling domain for the **Electrostatics** interface.

Model domain

1 In the **Definitions** toolbar, click  **Explicit**.

2 Select Domains 1, 4–7, and 9 only.

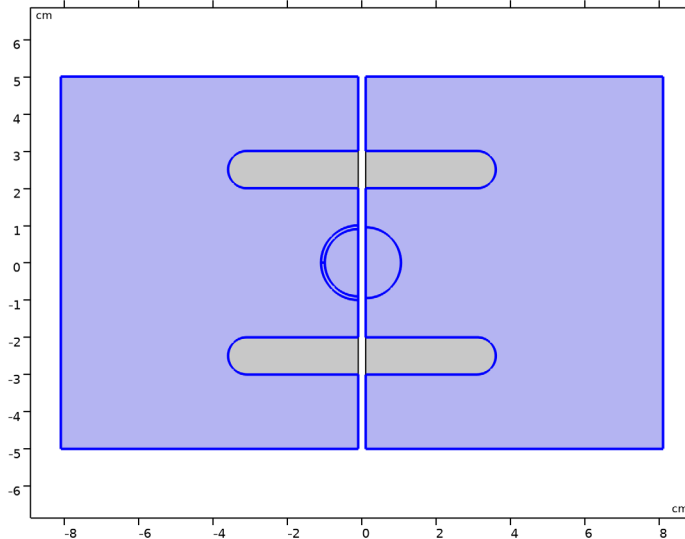

3 In the **Settings** window for **Explicit**, type Model domain in the **Label** text field. Now, add the physics features needed for the two sides of the model.

ELECTROSTATICS (ES)

Charge Conservation in Solids I

1 In the **Physics** toolbar, click  **Domains** and choose **Charge Conservation in Solids**.

2 Select Domains 4 and 5 only.

3 In the **Model Builder** window, click **Electrostatics (es)**.

4 In the **Settings** window for **Electrostatics**, locate the **Domain Selection** section.

5 From the **Selection** list, choose **Model domain**.

Ground I

1 In the **Physics** toolbar, click  **Boundaries** and choose **Ground**.

2 Select Boundaries 22, 24, 44, and 45 only.

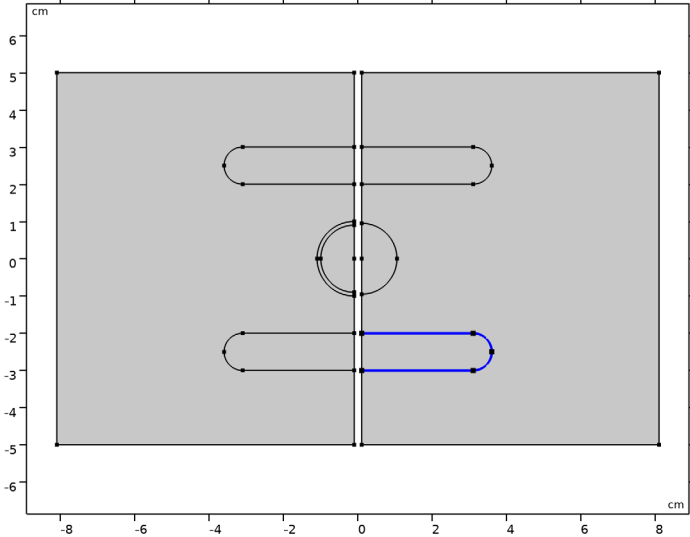

Ground 2

1 In the **Physics** toolbar, click  **Boundaries** and choose **Ground**.

2 Select Boundaries 4, 5, 34, and 35 only.

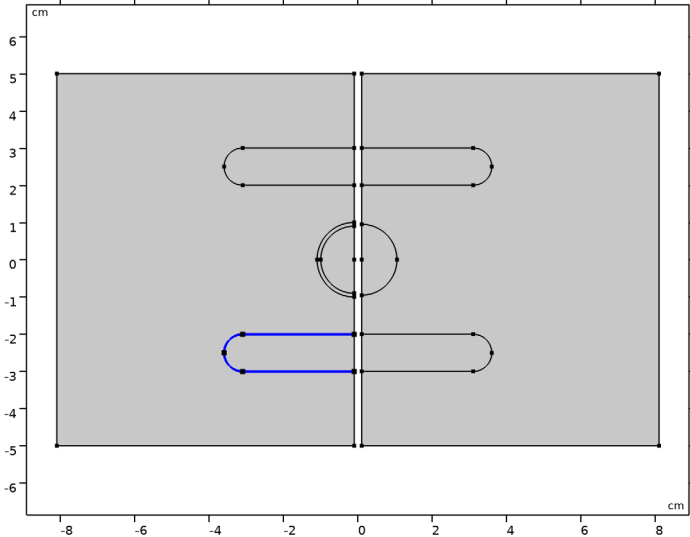

Boundary Terminal 1

- 1 In the **Physics** toolbar, click  **Boundaries** and choose **Boundary Terminal**.
- 2 Select Boundaries 29, 31, 46, and 47 only.

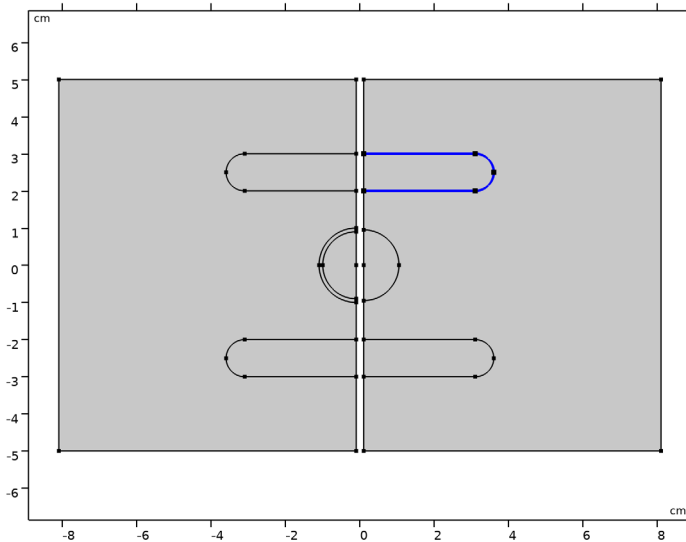

- 3 In the **Settings** window for **Boundary Terminal**, locate the **Terminal** section.
- 4 From the **Terminal type** list, choose **Voltage**.
- 5 In the V_0 text field, type V_0 .

Boundary Terminal 2

- 1 In the **Physics** toolbar, click  **Boundaries** and choose **Boundary Terminal**.

- 2 Select Boundaries 6, 7, 36, and 37 only.

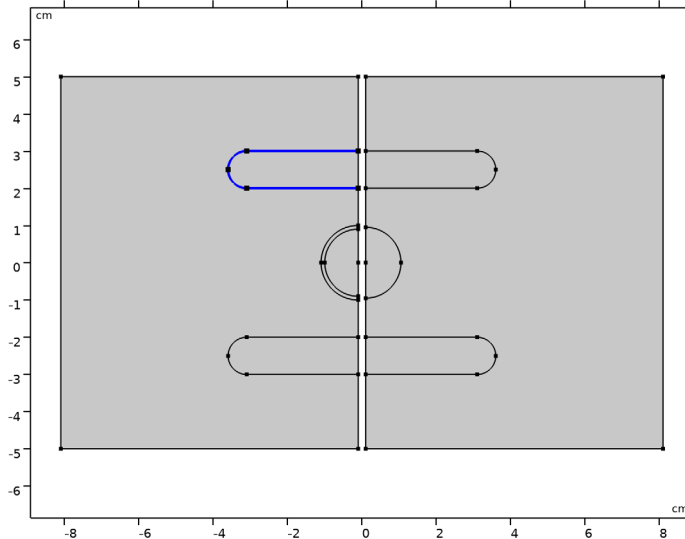

- 3 In the **Settings** window for **Boundary Terminal**, locate the **Terminal** section.
- 4 From the **Terminal type** list, choose **Voltage**.
- 5 In the V_0 text field, type V_0 .

Dielectric Shielding 1

- 1 In the **Physics** toolbar, click  **Boundaries** and choose **Dielectric Shielding**.
- 2 In the **Settings** window for **Dielectric Shielding**, locate the **Boundary Selection** section.
- 3 From the **Selection** list, choose **Dielectric shielding**.
- 4 Locate the **Electric Shielding** section. In the d_s text field, type 1 [mm].

Symmetry Plane 1

- 1 In the **Physics** toolbar, click  **Boundaries** and choose **Symmetry Plane**.
- 2 In the **Model Builder** window, click **Symmetry Plane 1**.
- 3 Select Boundaries 9, 11, 13, 14, 16, 18, 19, 23, 25–27, and 30 only.

MATERIALS

Material 1 (mat1)

- 1 In the **Model Builder** window, under **Component 1 (comp1)** right-click **Materials** and choose **Blank Material**.

- 2 In the **Settings** window for **Material**, locate the **Geometric Entity Selection** section.
- 3 From the **Selection** list, choose **Full fidelity**.
- 4 Locate the **Material Contents** section. In the table, enter the following settings:

Property	Variable	Value	Unit	Property group
Relative permittivity	epsilon _{nr_iso} ; epsilon _{nrii} = epsilon _{nr_iso} , epsilon _{nrij} = 0	er_b	l	Basic

Material 2 (mat2)

- 1 Right-click **Materials** and choose **Blank Material**.
- 2 In the **Settings** window for **Material**, locate the **Geometric Entity Selection** section.
- 3 From the **Geometric entity level** list, choose **Boundary**.
- 4 From the **Selection** list, choose **Dielectric shielding**.
- 5 Locate the **Material Contents** section. In the table, enter the following settings:

Property	Variable	Value	Unit	Property group
Relative permittivity	epsilon _{nr_iso} ; epsilon _{nrii} = epsilon _{nr_iso} , epsilon _{nrij} = 0	er_b	l	Basic

MESH I

In the **Model Builder** window, under **Component 1 (comp1)** right-click **Mesh 1** and choose **Build All**.

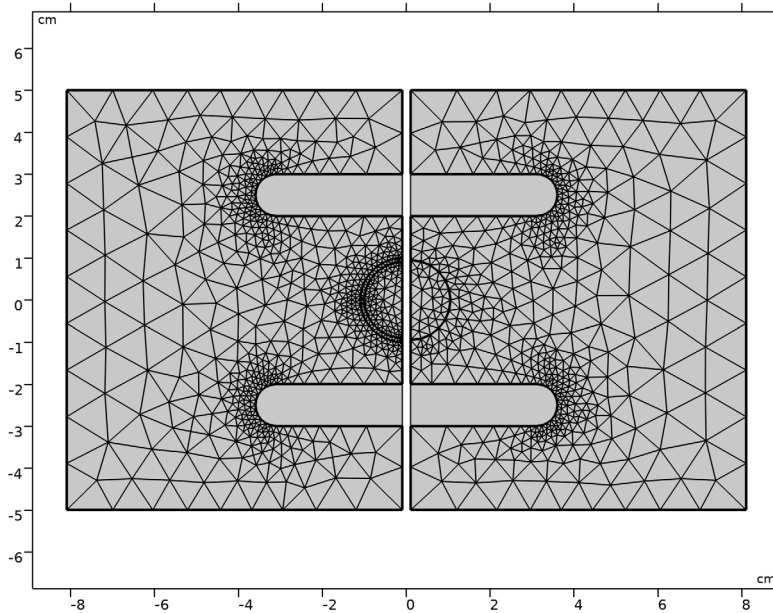

STUDY I

- 1 In the **Model Builder** window, click **Study 1**.
- 2 In the **Settings** window for **Study**, locate the **Study Settings** section.
- 3 Clear the **Generate default plots** checkbox.
- 4 In the **Study** toolbar, click **Compute**.

Create a custom plot to show the direction and norm of the electric field.

RESULTS

Electric Field (es)

- 1 In the **Results** toolbar, click **2D Plot Group**.
- 2 In the **Settings** window for **2D Plot Group**, type **Electric Field (es)** in the **Label** text field.

Surface 1

- 1 Right-click **Electric Field (es)** and choose **Surface**.

- 2 In the **Settings** window for **Surface**, click **Replace Expression** in the upper-right corner of the **Expression** section. From the menu, choose **Component 1 (comp1) > Electrostatics > Electric > es.normE - Electric field norm - V/m**.
- 3 Locate the **Coloring and Style** section. From the **Color table** list, choose **GrayPrint**.
- 4 Clear the **Color legend** checkbox.
- 5 From the **Color table transformation** list, choose **Reverse**.

Electric Field (es)

Next, add a contour plot showing the electric potential.

Contour 1

- 1 In the **Model Builder** window, right-click **Electric Field (es)** and choose **Contour**.
- 2 In the **Settings** window for **Contour**, locate the **Levels** section.
- 3 In the **Total levels** text field, type 21.

Color Expression 1

- 1 Right-click **Contour 1** and choose **Color Expression**.
- 2 In the **Settings** window for **Color Expression**, click **Replace Expression** in the upper-right corner of the **Expression** section. From the menu, choose **Component 1 (comp1) > Electrostatics > Electric > es.normE - Electric field norm - V/m**.

Electric Field (es)

Then, add a streamline plot of the electric field.

Streamline 1

- 1 In the **Model Builder** window, right-click **Electric Field (es)** and choose **Streamline**.

- 2 Select Boundaries 6, 29, 36, 37, 46, and 47 only.

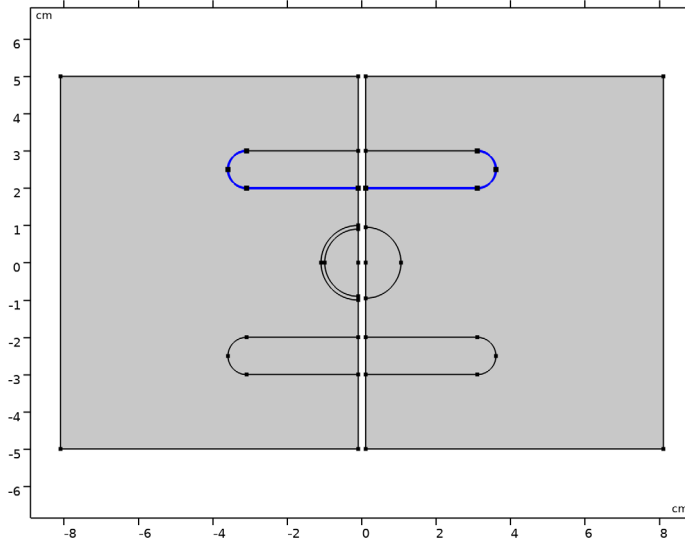

- 3 In the **Settings** window for **Streamline**, locate the **Streamline Positioning** section.
- 4 In the **Number** text field, type 40.

Color Expression 1

- 1 Right-click **Streamline 1** and choose **Color Expression**.
- 2 In the **Settings** window for **Color Expression**, click **Replace Expression** in the upper-right corner of the **Expression** section. From the menu, choose **Component 1 (comp1) > Electrostatics > Electric > es.normE - Electric field norm - V/m**.
- 3 Locate the **Coloring and Style** section. Clear the **Color legend** checkbox.
- 4 Click the  **Zoom Extents** button in the **Graphics** toolbar.
Compare the plot with [Figure 2](#).

Finish the result analysis by evaluating the capacitance of the system.

Global Evaluation 1

- 1 In the **Results** toolbar, click  **Global Evaluation**.
- 2 In the **Settings** window for **Global Evaluation**, locate the **Expressions** section.
- 3 In the table, enter the following settings:

Expression	Unit	Description
es.Q0_1/V0	F	

4 Click  **Evaluate**.



Global Evaluation 2

1 In the **Results** toolbar, click  **Global Evaluation**.

2 In the **Settings** window for **Global Evaluation**, locate the **Expressions** section.

3 In the table, enter the following settings:

Expression	Unit	Description
es.Q0_2/V0	F	

4 Click  next to  **Evaluate**, then choose **Table 1 - Global Evaluation 1**.

The capacitance should be about 13 pF in both cases.