



Model created in COMSOL Multiphysics 6.4

Tunable MEMS Capacitor

Introduction

In an electrostatically tunable parallel plate capacitor, the plate distance varies when the applied voltage changes. For tuning the distance between the plates, the capacitor includes a spring that attaches to one of the plates. If you know the spring characteristics and the voltage between the plates, you can compute the distance between the plates. This application shows an electrostatic simulation for a given distance. A postprocessing step then computes the capacitance.

The capacitor in this example is a typical component in various microelectromechanical systems (MEMS) for electromagnetic fields in the radio frequency range 300 MHz to 300 GHz.

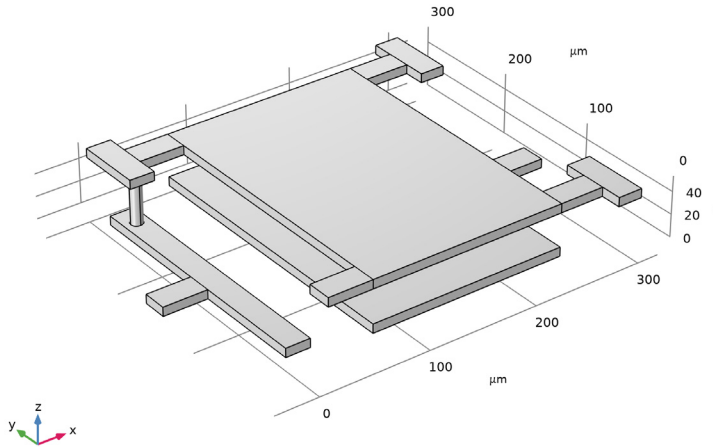

Figure 1: The tunable MEMS capacitor consists of two metal plates. The distance between the plates is tuned via a spring connected to one of the plates.

Model Definition

To solve the problem, use the 3D **Electrostatics, Boundary Elements** interface in the AC/DC Module. The capacitance is available directly as a variable for postprocessing.

The electric scalar potential, V , satisfies Poisson's equation,

$$-\nabla \cdot (\epsilon_0 \epsilon_r \nabla V) = \rho$$

where ϵ_0 is the permittivity of free space, ϵ_r is the relative permittivity, and ρ is the space charge density. The electric field and the displacement are obtained from the gradient of V :

$$\mathbf{E} = -\nabla V$$

$$\mathbf{D} = \epsilon_0 \epsilon_r \mathbf{E}$$

The capacitor plates and bars are assumed to be conductive and therefore have a uniform electric potential under electrostatic conditions.

In the **Electrostatics, Boundary Elements** interface, this phenomenon can be modeled by applying a **Terminal** condition to the external boundaries of the conductive regions. The boundaries will then behave like an equipotential. As the potential inside the conductors will have a uniform, predefined value, the model will only have to solve for the *Infinite void* surrounding the conductors.

Results and Discussion

Figure 2 shows the computed electric potential distribution near the capacitor plates. The potential on each capacitor plate is constant, as dictated by the applied conditions.

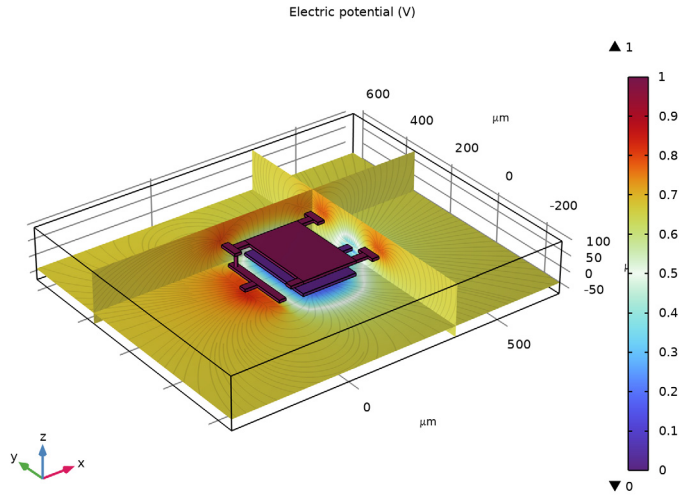

Figure 2: The electric potential distribution near the capacitor plates.

The capacitance, C , obtained from the simulation is approximately 0.1 pF.

Application Library path: ACDC_Module/Devices,_Capacitive/
capacitor_tunable



Modeling Instructions

From the **File** menu, choose **New**.

NEW



In the **New** window, click  **Model Wizard**.

MODEL WIZARD

- 1 In the **Model Wizard** window, click  **3D**.
- 2 In the **Select Physics** tree, select **AC/DC > Electric Fields and Currents > Electrostatics, Boundary Elements (esbe)**.
- 3 Click **Add**.
- 4 Click  **Study**.
- 5 In the **Select Study** tree, select **General Studies > Stationary**.
- 6 Click  **Done**.

GEOMETRY I

Insert the geometry sequence from the capacitor_tunable_geom_sequence.mph file.

- 1 In the **Geometry** toolbar, click **Insert Sequence** and choose **Insert Sequence**.
- 2 Browse to the model's Application Libraries folder and double-click the file capacitor_tunable_geom_sequence.mph.
- 3 In the **Geometry** toolbar, click  **Build All**.
- 4 Click the  **Go to Default View** button in the **Graphics** toolbar.

5 In the **Model Builder** window, under **Component 1 (comp1)** click **Geometry 1**.

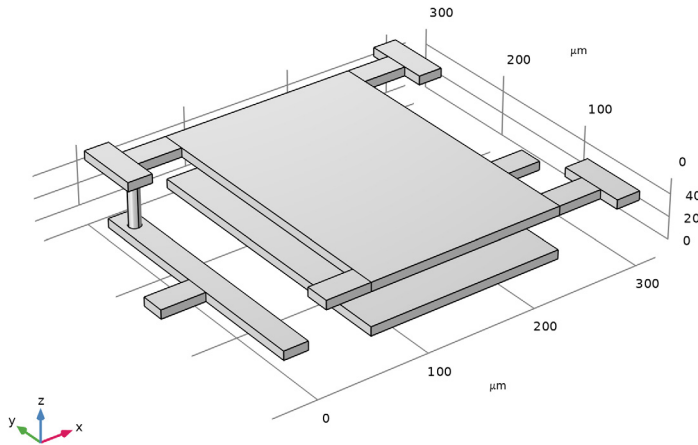

DEFINITIONS

Ground Plane

- 1 In the **Definitions** toolbar, click  **Explicit**.
- 2 In the **Settings** window for **Explicit**, type **Ground Plane** in the **Label** text field.
- 3 Select **Domain 2** only.

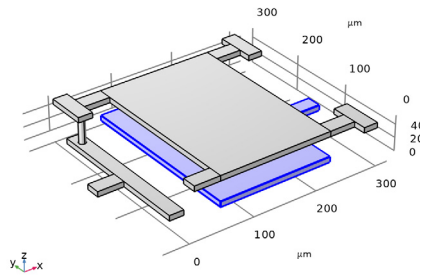

- 4 Locate the **Output Entities** section. From the **Output entities** list, choose **Adjacent boundaries**.

Terminal

- 1 In the **Definitions** toolbar, click  **Explicit**.

- 2 In the **Settings** window for **Explicit**, type Terminal in the **Label** text field.
- 3 Select Domain 1 only.

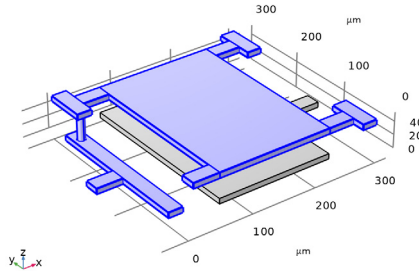

- 4 Locate the **Output Entities** section. From the **Output entities** list, choose **Adjacent boundaries**.

MATERIALS

Dielectric

- 1 In the **Model Builder** window, under **Component 1 (comp1)** right-click **Materials** and choose **Blank Material**.
- 2 In the **Settings** window for **Material**, type Dielectric in the **Label** text field.
- 3 Locate the **Geometric Entity Selection** section. From the **Selection** list, choose **All voids**.
- 4 Locate the **Material Contents** section. In the table, enter the following settings:

Property	Variable	Value	Unit	Property group
Relative permittivity	epsilon _{r_iso} ; epsilon _{r_ii} = epsilon _{r_iso} , epsilon _{r_ij} = 0	4.2	1	Basic

ELECTROSTATICS, BOUNDARY ELEMENTS (ESBE)

- 1 In the **Model Builder** window, under **Component 1 (comp1)** click **Electrostatics, Boundary Elements (esbe)**.
- 2 In the **Settings** window for **Electrostatics, Boundary Elements**, locate the **Domain Selection** section.
- 3 From the **Selection** list, choose **All voids**.

Ground 1

- 1 In the **Physics** toolbar, click  **Boundaries** and choose **Ground**.
- 2 In the **Settings** window for **Ground**, locate the **Boundary Selection** section.
- 3 From the **Selection** list, choose **Ground Plane**.

Boundary Terminal 1

The **Terminal** condition allows for feeding the system more easily. It automatically computes the lumped parameters of the system. In this model the capacitance is determined.

- 1 In the **Physics** toolbar, click  **Boundaries** and choose **Boundary Terminal**.
- 2 In the **Settings** window for **Boundary Terminal**, locate the **Boundary Selection** section.
- 3 From the **Selection** list, choose **Terminal**.
- 4 Locate the **Terminal** section. From the **Terminal type** list, choose **Voltage**.

MESH 1

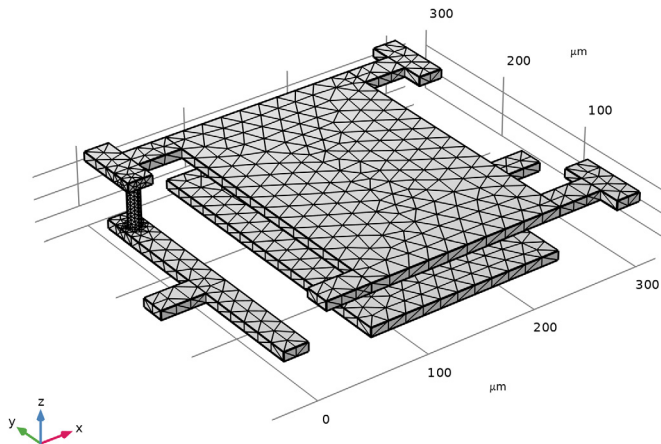

In the **Model Builder** window, under **Component 1 (comp1)** right-click **Mesh 1** and choose **Build All**.



STUDY 1

This particular model solves better when using the **Suggested Direct Solver**. Adjust the solver settings accordingly.

Solution 1 (sol1)

- 1 In the **Study** toolbar, click  **Show Default Solver**.
- 2 In the **Model Builder** window, expand the **Solution 1 (sol1)** node.
- 3 In the **Model Builder** window, expand the **Study 1 > Solver Configurations > Solution 1 (sol1) > Stationary Solver 1** node.
- 4 Right-click **Study 1 > Solver Configurations > Solution 1 (sol1) > Stationary Solver 1 > Suggested Direct Solver (esbe)** and choose **Enable**.
- 5 In the **Study** toolbar, click  **Compute**.

RESULTS

Electric Potential (esbe)

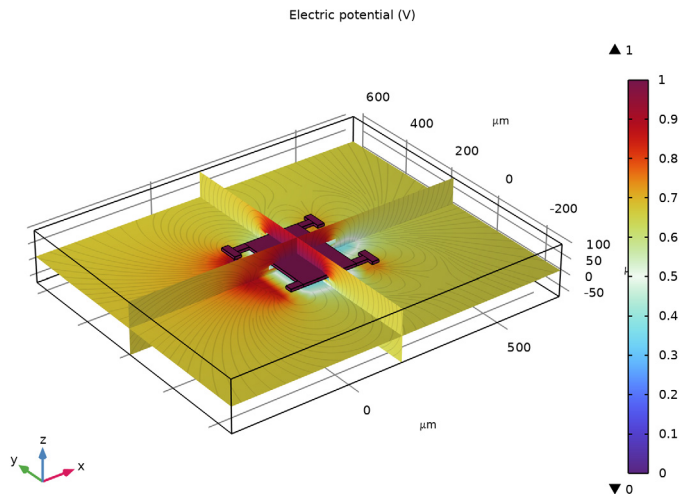

The first default plot shows the electric potential. Move the slices aside, to make the plot more insightful.

Multislice 1

- 1 In the **Model Builder** window, expand the **Electric Potential (esbe)** node, then click **Multislice 1**.
- 2 In the **Settings** window for **Multislice**, locate the **Multiplane Data** section.
- 3 Find the **x-planes** subsection. From the **Entry method** list, choose **Coordinates**.
- 4 In the **Coordinates** text field, type 320.

- 5 Find the **y-planes** subsection. From the **Entry method** list, choose **Coordinates**.
- 6 In the **Coordinates** text field, type 320.
- 7 Find the **z-planes** subsection. From the **Entry method** list, choose **Coordinates**.
- 8 In the **Coordinates** text field, type -20.

Streamline Multislice 1

- 1 In the **Model Builder** window, click **Streamline Multislice 1**.
- 2 In the **Settings** window for **Streamline Multislice**, locate the **Multiplane Data** section.
- 3 Find the **x-planes** subsection. From the **Entry method** list, choose **Coordinates**.
- 4 In the **Coordinates** text field, type 320.
- 5 Find the **y-planes** subsection. From the **Entry method** list, choose **Coordinates**.
- 6 In the **Coordinates** text field, type 320.
- 7 Find the **z-planes** subsection. From the **Entry method** list, choose **Coordinates**.
- 8 In the **Coordinates** text field, type -20.
- 9 In the **Electric Potential (esbe)** toolbar, click  **Plot**.

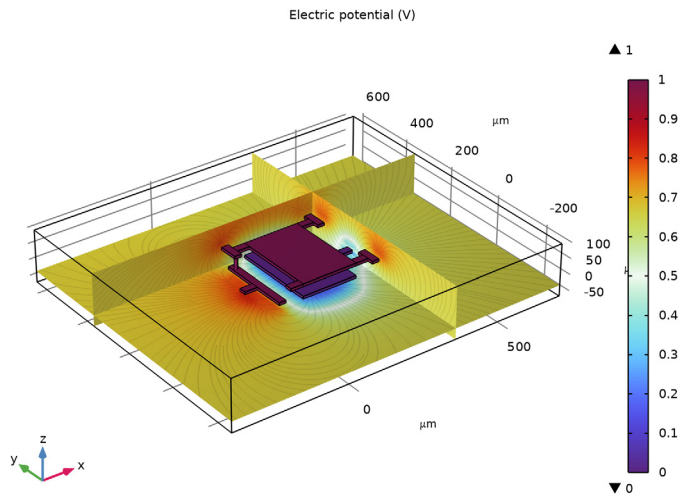



Multislice 1

- 1 In the **Model Builder** window, expand the **Results > Electric Field Norm (esbe)** node, then click **Multislice 1**.
- 2 In the **Settings** window for **Multislice**, locate the **Multiplane Data** section.

- 3 Find the **x-planes** subsection. From the **Entry method** list, choose **Coordinates**.
- 4 In the **Coordinates** text field, type 350.
- 5 Find the **y-planes** subsection. From the **Entry method** list, choose **Coordinates**.
- 6 In the **Coordinates** text field, type 350.

Streamline Multislice 1

- 1 In the **Model Builder** window, click **Streamline Multislice 1**.
- 2 In the **Settings** window for **Streamline Multislice**, locate the **Multiplane Data** section.
- 3 Find the **x-planes** subsection. From the **Entry method** list, choose **Coordinates**.
- 4 In the **Coordinates** text field, type 350.
- 5 Find the **y-planes** subsection. From the **Entry method** list, choose **Coordinates**.
- 6 In the **Coordinates** text field, type 350.
- 7 In the **Electric Field Norm (esbe)** toolbar, click  **Plot**.
- 8 Click the  **Zoom In** button in the **Graphics** toolbar.

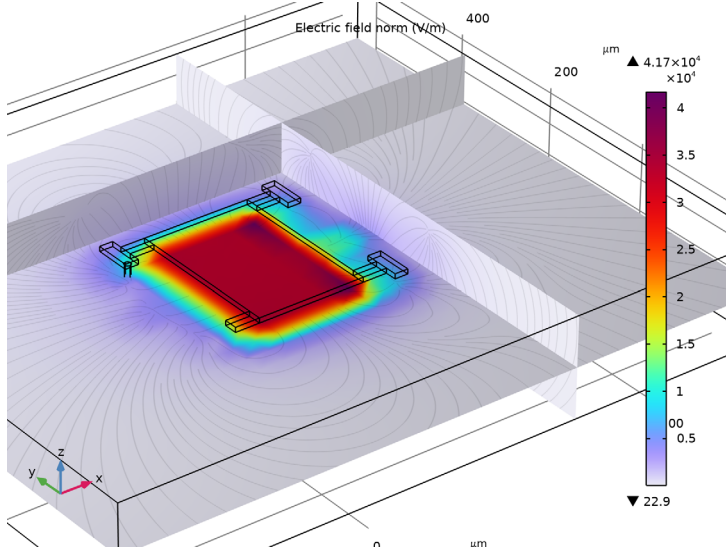

The second plot shows the electric field norm. The field is strongest in between the capacitor plates.

Global Evaluation 1

Having solved the model, you can now extract the capacitance.

- 1 In the **Results** toolbar, click  **Global Evaluation**.

- 2 In the **Settings** window for **Global Evaluation**, click **Replace Expression** in the upper-right corner of the **Expressions** section. From the menu, choose **Component 1 (compl) > Electrostatics, Boundary Elements > Terminals > esbe.Q0_1 - Terminal charge - C**.
- 3 Locate the **Expressions** section. In the table, enter the following settings:

Expression	Unit	Description
esbe.Q0_1/esbe.V0_1	pF	Maxwell capacitance

- 4 Click  **Evaluate**.

TABLE 1

- 1 Go to the **Table 1** window.

The capacitance evaluates to 0.1 pF.