



Model created in COMSOL Multiphysics 6.4

Frequency Domain Modeling of a Capacitor

Introduction

A capacitor with an applied sinusoidally time-varying voltage difference is modeled. A wide frequency range is considered and the impedance of the device is computed. Solver accuracy is addressed. The relationship between the frequency domain impedance and the steady-state capacitance and resistance of the device is discussed.

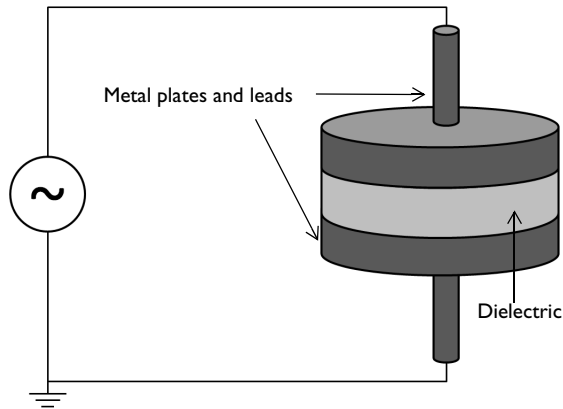

Figure 1: A simple capacitor composed of a disk of dielectric with metal plates on either side and lead wires. An AC signal is applied.

Model Definition

The capacitor being modeled is shown in [Figure 1](#), where two metal disks with leads are separated by a disk of quartz glass with relative permittivity $\epsilon_r = 4.2$ and a small electric conductivity $\sigma = 10^{-14}$ S/m. A region of surrounding air ($\epsilon_r = 1.0$, $\sigma = 0$ S/m) is also modeled to account for the fringing fields. A sinusoidally time-varying 10 kV source is connected to the leads and the resulting electric potential distribution is computed, along with the device admittance.

It is assumed that the capacitor plates are made of a highly conductive material, so that their total effective resistivity is much lower than that of the quartz. It is further assumed that the absolute magnitude of the current flow is small, which implies negligible magnetic fields and magnetically induced currents. Under these assumptions, the terminals can be assumed to be equipotential at any instant in time.

A separate electrostatic analysis can be used to compute the capacitance of the device, C . Similarly, a separate stationary Electric Currents analysis can be used to compute the conductance G of the cylinder of quartz. Under the previous assumptions, and for a device with no frequency-dependent material properties, the admittance can be computed from

$$Y(\omega) = G + j\omega C$$

where ω is the angular frequency of the excitation. It can be observed from this equation that as the frequency increases, the imaginary component of the admittance, the capacitive contribution, becomes many orders of magnitude larger than the real component, which is the conductive contribution.

In such cases, where the model is dominated by either conductive or capacitive effects, it can become necessary to change the default solver settings. The default solver for 3D electromagnetic problems uses an iterative approach, which means that the solution is found within a relative tolerance. The default relative tolerance for the iterative solver is 10^{-3} , but can be tightened up to 10^{-6} if needed. Beyond a relative tolerance of 10^{-6} it may become difficult for the iterative solver to converge. If even higher accuracy is needed, it is also possible to use a direct solver, although this does take more time and memory to solve. Both iterative and direct solvers are used and compared in this example.

Results and Discussion

The electric potential is plotted in [Figure 2](#). The admittance is computed and the real and imaginary components of the admittance are shown to be related to the steady state conductance and capacitance. When using the iterative solver, and as the capacitive effects begin to dominate the admittance, the conductive component of the admittance becomes less accurate. Once the real component of the admittance is less than six orders of magnitude smaller than the imaginary component, the results are below the tolerance threshold of the iterative solver, and the real component of the admittance is no longer accurate. Using the direct solver can improve this accuracy.

Irrespective of the solver used, and the tolerance specified, the dominant component of the admittance is computed correctly. This device is primarily capacitive, and such capacitive behavior is captured correctly even with the default solver settings. The total

resistive losses within the dielectric are also computed correctly, regardless of solver method.

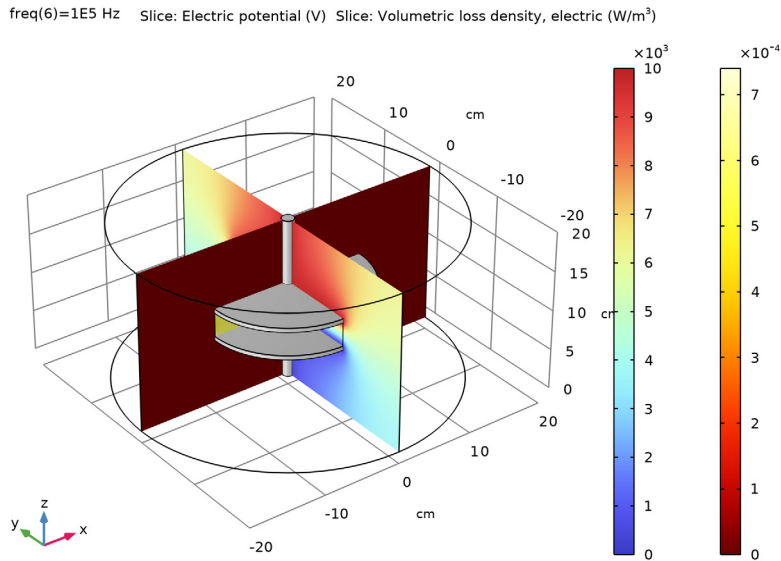



Figure 2: The electric potential and resistive losses in the dielectric and in the air domain surrounding the capacitor.

Application Library path: ACDC_Module/Introductory_Electric_Currents/capacitor_ac

Modeling Instructions



From the **File** menu, choose **New**.

NEW

In the **New** window, click  **Model Wizard**.

MODEL WIZARD

I In the **Model Wizard** window, click  **3D**.



- 2 In the **Select Physics** tree, select **AC/DC > Electric Fields and Currents > Electric Currents (ec)**.
- 3 Click **Add**.
- 4 Click  **Study**.
- 5 In the **Select Study** tree, select **General Studies > Frequency Domain**.
- 6 Click  **Done**.

GEOMETRY I

- 1 In the **Model Builder** window, under **Component I (comp1)** click **Geometry I**.
- 2 In the **Settings** window for **Geometry**, locate the **Units** section.
- 3 From the **Length unit** list, choose **cm**.

First, create a cylinder for the model domain.

Cylinder 1 (cyl1)

- 1 In the **Geometry** toolbar, click  **Cylinder**.
- 2 In the **Settings** window for **Cylinder**, locate the **Size and Shape** section.
- 3 In the **Radius** text field, type 20.
- 4 In the **Height** text field, type 20.
- 5 Click  **Build Selected**.

Choose wireframe rendering to get a better view of the interior parts.

- 6 Click the  **Wireframe Rendering** button in the **Graphics** toolbar.

Then, add a cylinder for the disc of dielectric with the two metal plates.

Cylinder 2 (cyl2)

- 1 In the **Geometry** toolbar, click  **Cylinder**.
- 2 In the **Settings** window for **Cylinder**, locate the **Size and Shape** section.
- 3 In the **Radius** text field, type 10.
- 4 In the **Height** text field, type 4.
- 5 Locate the **Position** section. In the **z** text field, type 8.
- 6 Click to expand the **Layers** section. In the table, enter the following settings:

Layer name	Thickness (cm)
Layer 1	5 [mm]

- 7 Clear the **Layers on side** checkbox.

8 Select the **Layers on bottom** checkbox.

9 Select the **Layers on top** checkbox.

Finish the geometry by adding two cylinders for the leads.

Cylinder 3 (cyl3)

1 In the **Geometry** toolbar, click  **Cylinder**.

2 In the **Settings** window for **Cylinder**, locate the **Size and Shape** section.

3 In the **Radius** text field, type 0.75.

4 In the **Height** text field, type 8.

5 Click  **Build Selected**.

Cylinder 4 (cyl4)

1 Right-click **Cylinder 3 (cyl3)** and choose **Duplicate**.

2 In the **Settings** window for **Cylinder**, locate the **Position** section.

3 In the **z** text field, type 12.

4 Click  **Build All Objects**.

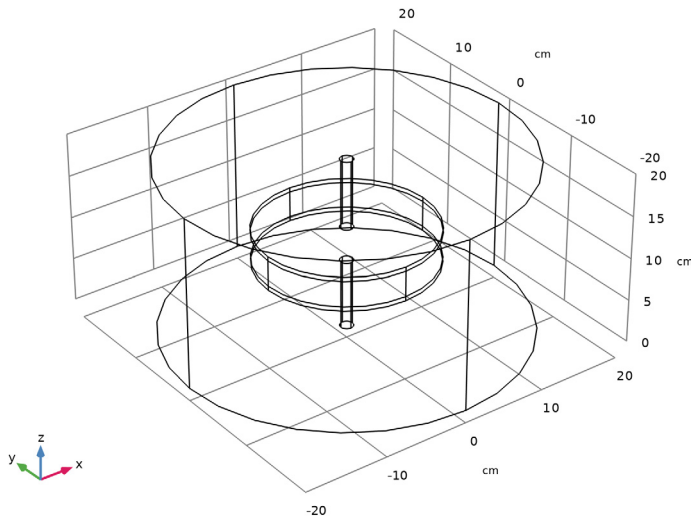

ELECTRIC CURRENTS (EC)

The model is composed of a disc of dielectric material with metal plates on either side and two lead wires. To get a better view, hide some of the boundaries. Begin by selecting the **Electric Currents** interface, then add a **Hide** node.

DEFINITIONS

Hide for Physics I

- 1 In the **Model Builder** window, expand the **Component 1 (comp1)** > **Definitions** node.
- 2 Right-click **View 1** and choose **Hide for Physics**.
- 3 In the **Settings** window for **Hide for Physics**, locate the **Geometric Entity Selection** section.
- 4 From the **Geometric entity level** list, choose **Boundary**.
- 5 Select Boundaries 1, 4, and 23 only.

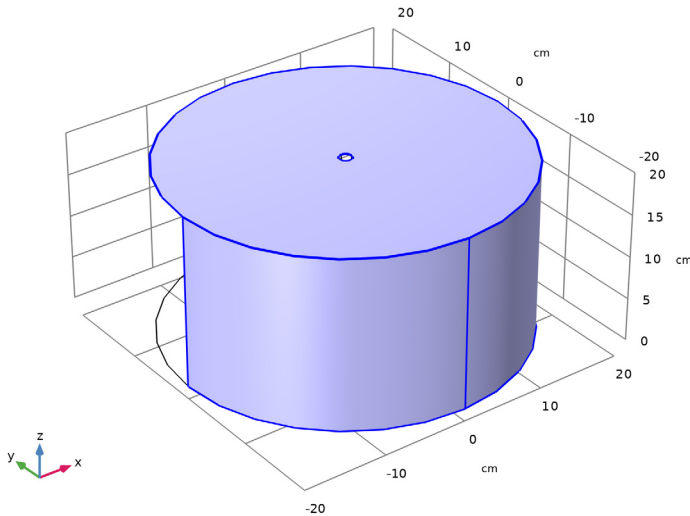

Even though not strictly necessary for a closed electrode, the domains inside the ground surfaces are disabled with the next instructions. This is the suggested model setup whenever the electrode is considered to be equipotential as this is excluding any possible numerical issue due to the large contrast in material properties.

ELECTRIC CURRENTS (EC)

- 1 In the **Model Builder** window, under **Component 1 (comp1)** click **Electric Currents (ec)**.
- 2 Select Domains 1, 3, 4, and 6 only.

Domain Terminal I

- 1 In the **Physics** toolbar, click  **Domains** and choose **Domain Terminal**.
- 2 Select Domains 4 and 6 only.
- 3 In the **Settings** window for **Domain Terminal**, locate the **Terminal** section.

- 4 From the **Terminal type** list, choose **Voltage**.
- 5 In the V_0 text field, type 10[kV].

DEFINITIONS

Explicit 1

- 1 In the **Definitions** toolbar, click  **Explicit**.
- 2 Select Domains 2 and 5 only.
- 3 In the **Settings** window for **Explicit**, locate the **Output Entities** section.
- 4 From the **Output entities** list, choose **Adjacent boundaries**.



ELECTRIC CURRENTS (EC)

Ground 1

- 1 In the **Physics** toolbar, click  **Boundaries** and choose **Ground**.
- 2 In the **Settings** window for **Ground**, locate the **Boundary Selection** section.
- 3 From the **Selection** list, choose **Explicit 1**.

Next, assign material properties to the model. Begin by specifying **Air** for all domains.

ADD MATERIAL

- 1 In the **Home** toolbar, click  **Add Material** to open the **Add Material** window.
- 2 Go to the **Add Material** window.
- 3 In the tree, select **Built-in > Air**.
- 4 Click the **Add to Component** button in the window toolbar.
Override the dielectric disc with glass (quartz).
- 5 In the tree, select **Built-in > Glass (quartz)**.
- 6 Click the **Add to Component** button in the window toolbar.
- 7 In the **Materials** toolbar, click  **Add Material** to close the **Add Material** window.

MATERIALS

Glass (quartz) (mat2)

Select Domain 3 only.

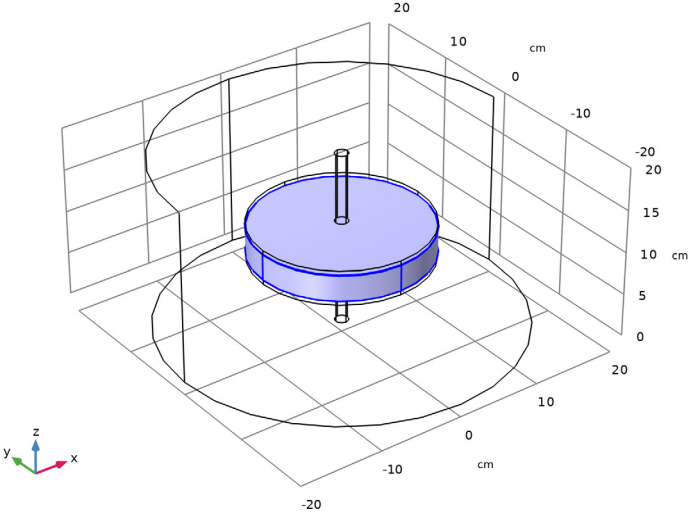

MESH I

In the **Model Builder** window, under **Component I (comp1)** right-click **Mesh I** and choose **Build All**.

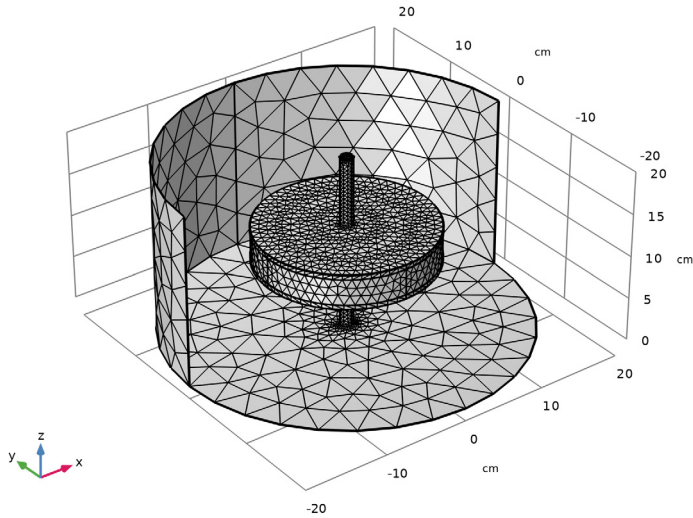

STUDY I

- 1 In the **Model Builder** window, click **Study I**.
- 2 In the **Settings** window for **Study**, locate the **Study Settings** section.
- 3 Clear the **Generate default plots** checkbox.

Step 1: Frequency Domain

- 1 In the **Model Builder** window, under **Study I** click **Step 1: Frequency Domain**.
- 2 In the **Settings** window for **Frequency Domain**, locate the **Study Settings** section.
- 3 In the **Frequencies** text field, type 1 10 100 1000 10000 100000.
- 4 From the **Tolerance** list, choose **User controlled**.
- 5 In the **Relative tolerance** text field, type $1e-6$.
- 6 In the **Study** toolbar, click **Compute**.

Add a **Selection** to the first solution. This selection will only include the air and the glass. Domains that are excluded from the selection will be hidden in the corresponding plots.

RESULTS

In the **Model Builder** window, expand the **Results** node.

Study 1/Solution 1 (sol1)

In the **Model Builder** window, expand the **Results > Datasets** node, then click **Study 1/Solution 1 (sol1)**.

Selection

- 1 In the **Results** toolbar, click  **Attributes** and choose **Selection**.
- 2 In the **Settings** window for **Selection**, locate the **Geometric Entity Selection** section.
- 3 From the **Geometric entity level** list, choose **Domain**.
- 4 Select Domains 1 and 3 only.

Add a duplicate solution and set a selection for the metal parts.

Study 1/Solution 1 (2) (sol1)

In the **Results** toolbar, click  **More Datasets** and choose **Solution**.

Selection

- 1 In the **Results** toolbar, click  **Attributes** and choose **Selection**.
- 2 In the **Settings** window for **Selection**, locate the **Geometric Entity Selection** section.
- 3 From the **Geometric entity level** list, choose **Domain**.
- 4 Select Domains 2 and 4–6 only.

3D Plot Group 1

In the **Results** toolbar, click  **3D Plot Group**.

The metal parts can be visualized by choosing **Uniform** for the coloring type. In this case the purpose of the plot is not to show a quantity, but to show a shape. The variable that the plot is based on is of no importance. Create a surface plot for this purpose.

Surface 1

- 1 Right-click **3D Plot Group 1** and choose **Surface**.
- 2 In the **Settings** window for **Surface**, locate the **Data** section.
- 3 From the **Dataset** list, choose **Study 1/Solution 1 (2) (sol1)**.
- 4 Click to expand the **Title** section. From the **Title type** list, choose **None**.
- 5 Locate the **Coloring and Style** section. From the **Coloring** list, choose **Uniform**.
- 6 From the **Color** list, choose **Gray**.

Add slice plots for the norm of the electric potential and resistive losses.

Slice 1

- 1 In the **Model Builder** window, right-click **3D Plot Group 1** and choose **Slice**.

- 2 In the **Settings** window for **Slice**, locate the **Plane Data** section.
- 3 In the **Planes** text field, type 1.
- 4 Locate the **Coloring and Style** section. From the **Color table** list, choose **RainbowLight**.

Slice 2

- 1 Right-click **3D Plot Group 1** and choose **Slice**.
- 2 In the **Settings** window for **Slice**, click **Replace Expression** in the upper-right corner of the **Expression** section. From the menu, choose **Component 1 (comp 1) > Electric Currents > Heating and losses > ec.Qrh - Volumetric loss density, electric - W/m³**.
- 3 Locate the **Plane Data** section. From the **Plane** list, choose **zx-planes**.
- 4 In the **Planes** text field, type 1.
- 5 Locate the **Coloring and Style** section. From the **Color table** list, choose **Thermal**.
- 6 In the **3D Plot Group 1** toolbar, click  **Plot**.
Compare the resulting plot with that in [Figure 2](#).

Global Evaluation 1

- 1 In the **Results** toolbar, click  **Global Evaluation**.
- 2 In the **Settings** window for **Global Evaluation**, locate the **Expressions** section.
- 3 In the table, enter the following settings:

Expression	Unit	Description
ec.Y11	S	Admittance, 11 component

- 4 Click  **Evaluate**.

Global Evaluation 2

- 1 In the **Results** toolbar, click  **Global Evaluation**.
- 2 In the **Settings** window for **Global Evaluation**, locate the **Expressions** section.
- 3 In the table, enter the following settings:

Expression	Unit	Description
imag(ec.Y11) / ec.omega	F	

- 4 Click  **Evaluate**.

Volume Integration 1

- 1 In the **Results** toolbar, click  **More Derived Values** and choose **Integration > Volume Integration**.

- 2 Select Domain 3 only.
- 3 In the **Settings** window for **Volume Integration**, locate the **Expressions** section.
- 4 In the table, enter the following settings:

Expression	Unit	Description
ec.Qrh	W	Volumetric loss density, electric

- 5 Click  **Evaluate**.

STUDY 1

Next, use the direct solver to improve the accuracy of the conductive component of the admittance.

Solution 1 (sol1)

- 1 In the **Model Builder** window, expand the **Study 1 > Solver Configurations** node.
- 2 In the **Model Builder** window, expand the **Solution 1 (sol1)** node.
- 3 In the **Model Builder** window, expand the **Study 1 > Solver Configurations > Solution 1 (sol1) > Stationary Solver 1** node.
- 4 Right-click **Direct** and choose **Enable**.
- 5 In the **Study** toolbar, click  **Compute**.

RESULTS

Global Evaluation 1

- 1 In the **Model Builder** window, under **Results > Derived Values** click **Global Evaluation 1**.
- 2 In the **Settings** window for **Global Evaluation**, click  **Evaluate**.

Global Evaluation 2

- 1 In the **Model Builder** window, click **Global Evaluation 2**.
- 2 In the **Settings** window for **Global Evaluation**, click  **Evaluate**.

Volume Integration 1

- 1 In the **Model Builder** window, click **Volume Integration 1**.
- 2 In the **Settings** window for **Volume Integration**, click  **Evaluate**.

3D Plot Group 1

Now, compare the values in **Table I**. Set the table to **Full Precision** using the buttons in the tables toolbar. The real part of the admittance should be much more consistent at higher

frequencies when using the direct solver. For the capacitance and the resistive losses, the difference is less prominent (see **Table 2** and **Table 3**).