



Model created in COMSOL Multiphysics 6.4

# Axisymmetric Approximation of 3D Inductor

## Introduction

---

When the frequency is high enough, capacitive effects can become important also for devices that are inductive and/or resistive at lower frequencies. Modeling this effect in an inductor requires accounting for electric field components both parallel and perpendicular to the wire. This easily leads to the conclusion that a 3D model is always necessary even if the coil is a low slant helix. This is not always the case, as shown in this tutorial.

Starting from the 3D inductor model described in the *Introduction to AC/DC Module* manual, a 2D axisymmetric model able to describe a self resonating inductor is created. In order to build an equivalent 2D axisymmetric model, an effective axisymmetric core is drawn and the RLC Coil Group feature is used.

The method shown here is particularly suitable for studying systems with thousands of turns, such as sensors or transformers, with limited computational power.

## Model Definition

---

The 3D solution of the power inductor of [Figure 1](#) is presented in the manual *Introduction to AC/DC Module*. We are considering the same system.

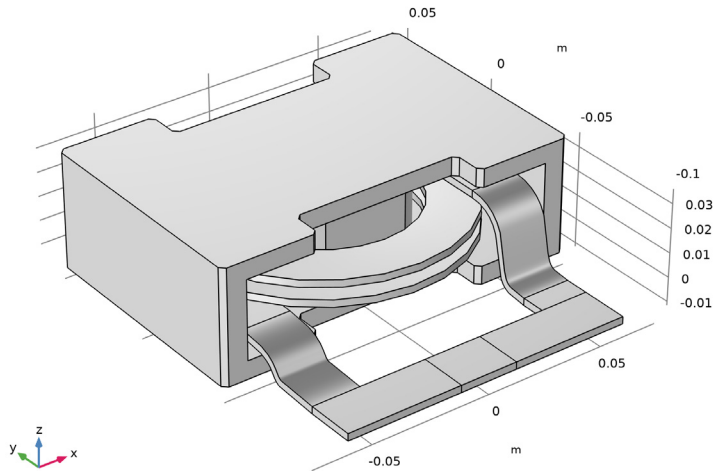

*Figure 1: The 3D geometry representation of the power inductor under study.*

In that device, the coil can be treated, to a reasonable level of approximation, as axisymmetric. Therefore, any of its cross-sections are suitable for performing a 2D axisymmetric analysis from a geometric point of view.

On the other hand, the core geometry shape indicates that a 3D analysis is required. However, in order to have a description that is correct from a magnetic point of view, the core does not have to be rotationally symmetric as long as

- it is not supporting 3D nonaxisymmetric eddy currents
- an equivalent axisymmetric geometry respecting the original core reluctance is used

Such a construction, that is, replacing the 3D core with a 2D axisymmetric representation that preserves the crucial area that influences the magnetic circuit, is shown in [Figure 2](#).

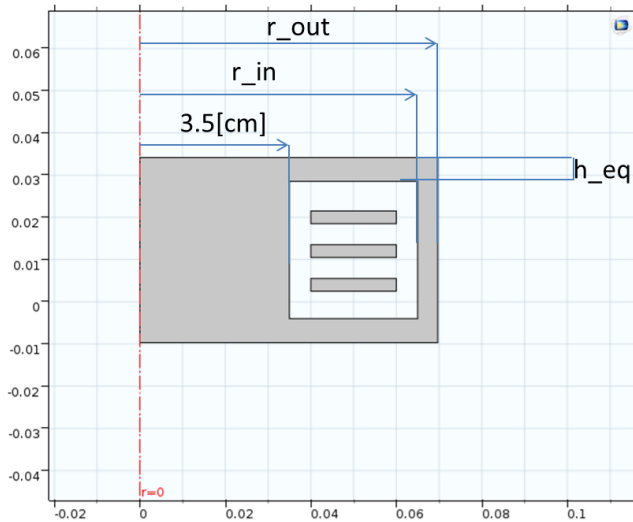

*Figure 2: The 2D axisymmetric geometry equivalent to the power inductor under study.*

The parameters are defined in [Table 1](#). The original external column area (as given by the *Outer column section area* variable in [Table 1](#)) is the area represented in [Figure 3](#). It is set exactly to  $\pi(r_{\text{out}}^2 - r_{\text{in}}^2)$  in the 2D axisymmetric geometry. Some parameters are directly measured from the original 3D geometry such as the *Outer column internal radius* and the *Upper magnetic circuit closure*.

The coil geometry representation in 2D axial symmetry is directly taken from the midplane cross section in the  $xz$ -plane in 3D. [Figure 4](#) shows the final 2D axisymmetric geometry.

TABLE I: QUOTA OF THE 3D AND THE 2D AXISYMMETRIC EQUIVALENT.

	3D	2D axial symmetry	2D axisymmetric variable name
Inner column radius	3.5 cm	3.5 cm	-
Outer column internal radius	6.5 cm	6.5 cm	$r_{in}$ (measured from 3D)
Outer column section area	19.92 cm <sup>2</sup>	Identical by construction	external_area
Outer column external radius	-	$\sqrt{\text{external\_area}/\pi+r_{in}^2}$	$r_{out}$
Upper magnetic circuit closure area	7.5 cm <sup>2</sup>	Identical by construction	upper_area (measured from 3D)
Upper magnetic circuit closure	-	upper_area/ $\pi/r_{in}$	$h_{eq}$

The main challenge of the 2D axisymmetric coil model is to account for the way that the electric currents will flow. The RLC Coil Group feature available in the Magnetic and Electric Fields interface automatically takes into account that the currents are balanced among

- 1 conduction currents and induced currents that are flowing in the azimuthal direction
- 2 displacement currents that flow in the  $rz$ -plane from one turn to the other

In the low-frequency limit, currents are all of the first type. In the high-frequency limit, the currents are all of the second type. At some intermediate frequency there is a resonant frequency where inductive and capacitive effects perfectly balance and the coil self-resonates. At this frequency the inductor is purely resistive and the total loss peaks as a function of frequency.

In this model the core is not grounded and there is no other external electric ground. Compared to a real system where the inductor often is mounted on or near a ground plane, this may cause a shift in the resonance frequency. This is easily added, for example by applying one or more electric boundary conditions to the core boundaries.

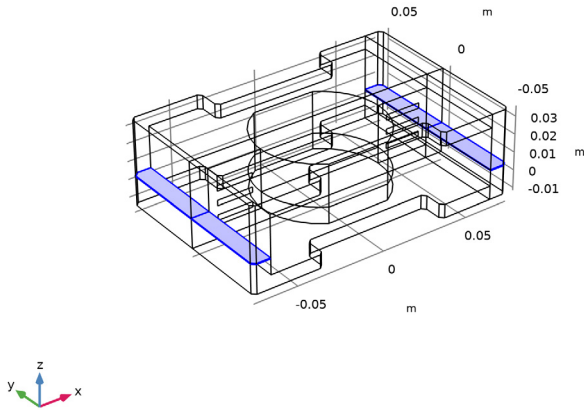

Figure 3: The 3D cross sectional area of the outer columns used to compute the 2D axisymmetric outer columns width.

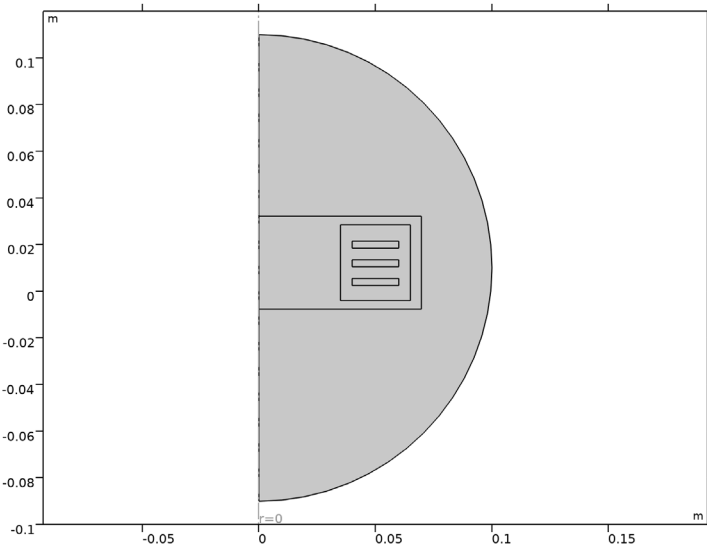

Figure 4: The 2D axisymmetric geometry including some surrounding air.

## Results and Discussion

The field and loss plots can be compared to the 3D model discussed in the *Introduction to AC/DC Module* manual.

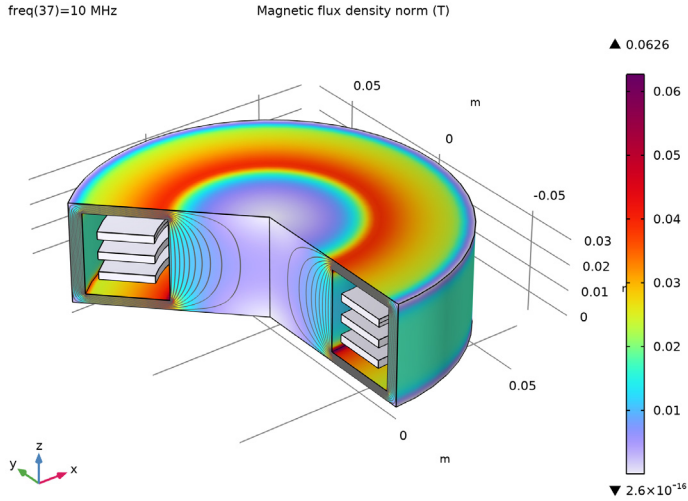

Figure 5: Magnetic flux density in the revolved 2D geometry.

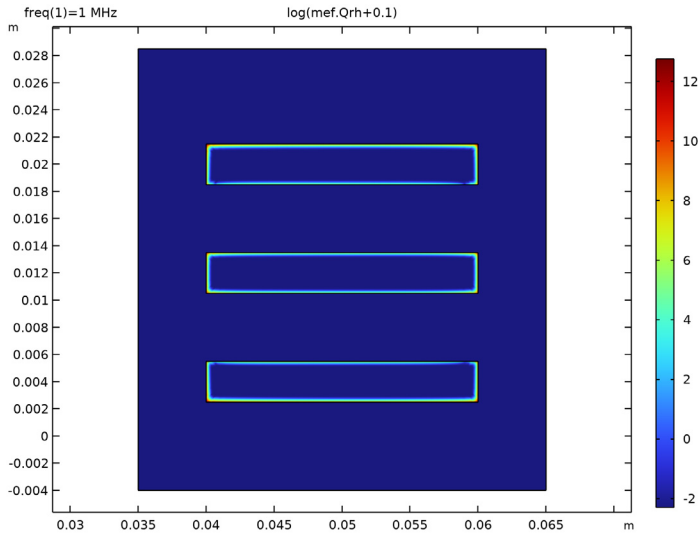
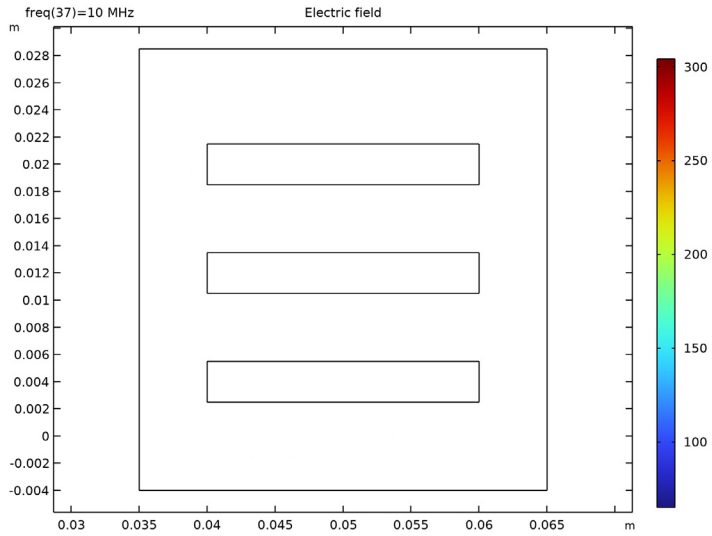
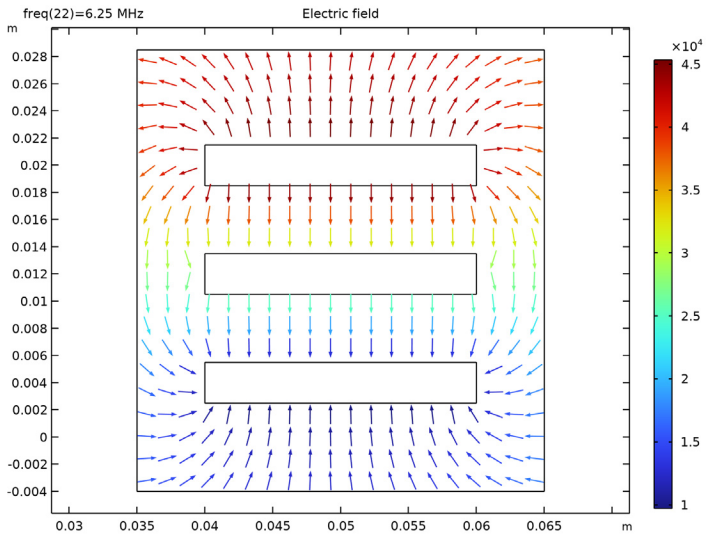

Figure 6: The eddy current losses are shown (log scale with zero offset).

The in-plane electric field magnitude strongly depends on the frequency, as is clearly shown from comparing [Figure 7](#) and [Figure 8](#).



*Figure 7: Electric field between turns far from the resonance frequency.*



*Figure 8: Electric field between turns at the resonance frequency.*

The most striking sign of the resonance is shown in Figure 9, where the real and imaginary parts of the coil impedance are shown. The resistance (blue curve) is shown in tens of  $k\Omega$  together with the reactance divided by the angular frequency (green curve). The green curve starts at low frequencies from the static inductance, grows, and then becomes negative. When the green curve becomes negative, it means that the coil behaves like a capacitor. The real part of the impedance accounts for losses, and peaks at the frequency where the capacitive and the inductive contributions to the overall system impedance balance out. The position and value of the peak featured by the 2D axisymmetric model also match the ones of the original 3D model in the *Introduction to AC/DC Module* manual fairly well.

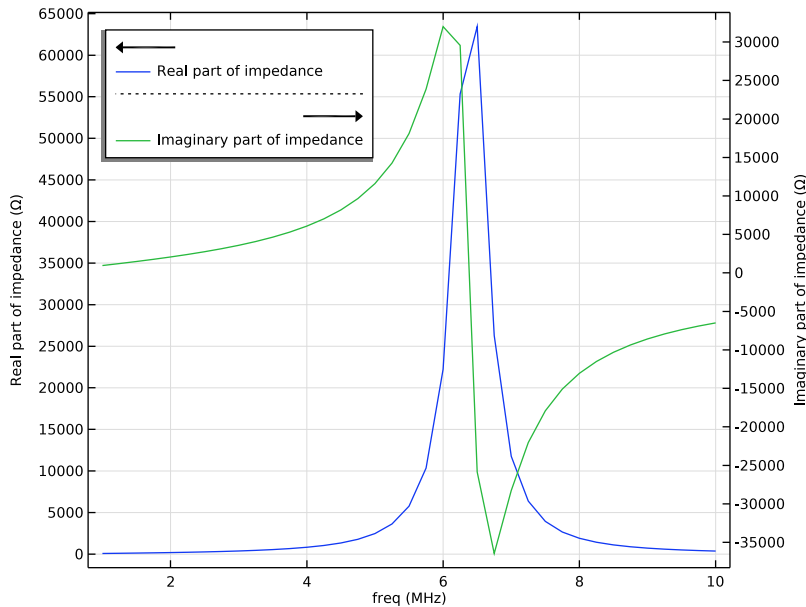

Figure 9: The inductor impedance as a function of frequency. Compare this plot to the corresponding plot of the 3D Inductor in the *Introduction to AC/DC Module* manual.

---

**Application Library path:** ACDC\_Module/Devices,\_Inductive/  
axisymmetric\_approximation\_of\_inductor\_3d

---

## Modeling Instructions



---

From the **File** menu, choose **New**.

### NEW

In the **New** window, click  **Model Wizard**.

### MODEL WIZARD



- 1 In the **Model Wizard** window, click  **2D Axisymmetric**.
- 2 In the **Select Physics** tree, select **AC/DC** > **Electromagnetic Fields** > **Vector Formulations** > **Magnetic and Electric Fields (mef)**.
- 3 Click **Add**.
- 4 In the **Added physics interfaces** tree, select **Magnetic and Electric Fields (mef)**.
- 5 Click  **Study**.
- 6 In the **Select Study** tree, select **General Studies** > **Frequency Domain**.
- 7 Click  **Done**.

First import the 3D geometry and take some measurements to generate the axisymmetric equivalent.

### PART I

In the **Model Builder** window, right-click **Global Definitions** and choose **Geometry Parts** > **3D Part**.



#### *Import 1 (impl)*

- 1 In the **Geometry** toolbar, click  **Import**.
- 2 In the **Settings** window for **Import**, locate the **Source** section.
- 3 Click  **Browse**.
- 4 Browse to the model's Application Libraries folder and double-click the file `inductor_3d.mphbin`.

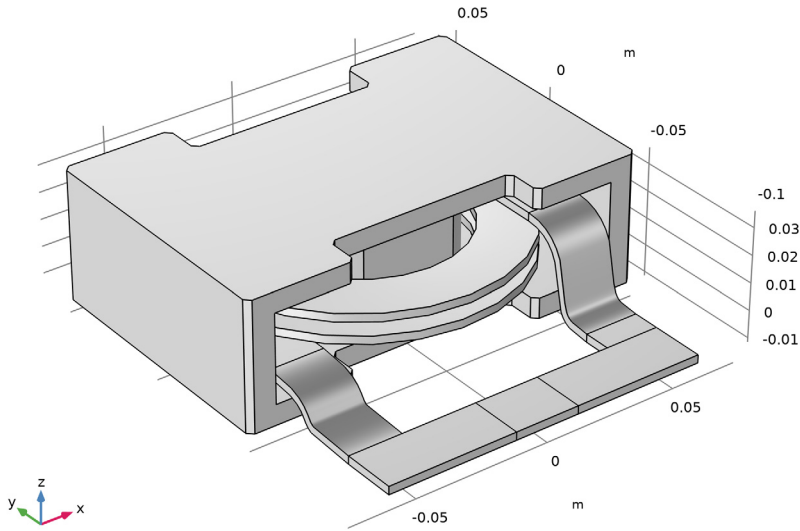
5 Click  **Import**.



#### *Work Plane 1 (wp1)*

- 1 In the **Geometry** toolbar, click  **Work Plane**.
- 2 In the **Settings** window for **Work Plane**, locate the **Plane Definition** section.
- 3 From the **Plane** list, choose **xz-plane**.
- 4 Click  **Go to Plane Geometry**.

#### *Work Plane 1 (wp1) > Cross Section 1 (cro1)*

- 1 In the **Work Plane** toolbar, click  **Cross Section**.
- 2 In the **Settings** window for **Cross Section**, click  **Build Selected**.

#### *Work Plane 1 (wp1)*

- 1 In the **Model Builder** window, under **Global Definitions > Geometry Parts > Part 1** click **Work Plane 1 (wp1)**.
- 2 In the **Settings** window for **Work Plane**, click  **Build Selected**.

#### *Delete Entities 1 (del1)*

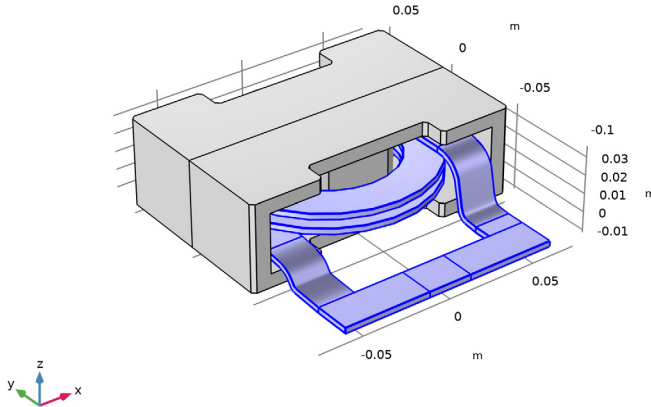

- 1 In the **Model Builder** window, right-click **Part 1** and choose **Delete Entities**.
- 2 In the **Settings** window for **Delete Entities**, locate the **Entities or Objects to Delete** section.

- 3 From the **Geometric entity level** list, choose **Domain**.
- 4 On the object **impl1**, select Domains 2–5 only.
- 5 Click the  **Zoom Extents** button in the **Graphics** toolbar.



- 6 Click  **Build Selected**.

*Work Plane 2 (wp2)*

- 1 In the **Geometry** toolbar, click  **Work Plane**.
- 2 In the **Settings** window for **Work Plane**, locate the **Plane Definition** section.
- 3 In the **z-coordinate** text field, type 5[mm].
- 4 Click  **Go to Plane Geometry**.

*Work Plane 2 (wp2) > Cross Section 1 (cro1)*

- 1 In the **Work Plane** toolbar, click  **Cross Section**.
- 2 In the **Settings** window for **Cross Section**, click  **Build Selected**.

*Work Plane 2 (wp2)*

- 1 In the **Model Builder** window, under **Global Definitions > Geometry Parts > Part 1** click **Work Plane 2 (wp2)**.
- 2 In the **Settings** window for **Work Plane**, click  **Build Selected**.

*Work Plane 3 (wp3)*

- 1 In the **Geometry** toolbar, click  **Work Plane**.

- 2 In the **Settings** window for **Work Plane**, locate the **Plane Definition** section.
- 3 From the **Plane type** list, choose **Face parallel**.
- 4 On the object **dell**, select Boundary 46 only.

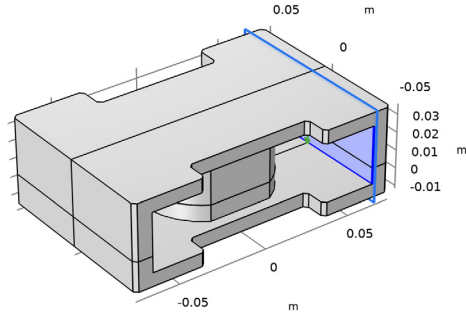

- 5 Click  **Go to Plane Geometry**.

*Work Plane 3 (wp3) > Cross Section 1 (cro1)*

- 1 In the **Work Plane** toolbar, click  **Cross Section**.
- 2 In the **Settings** window for **Cross Section**, click  **Build Selected**.

## GLOBAL DEFINITIONS

Add parameters for drawing the axisymmetric equivalent core.

*Parameters 1*

- 1 In the **Model Builder** window, under **Global Definitions** click **Parameters 1**.
- 2 In the **Settings** window for **Parameters**, locate the **Parameters** section.
- 3 In the table, enter the following settings:



Name	Expression	Value	Description
external_area	0.001992[m^2]	0.001992 m <sup>2</sup>	3D area of one of the two lateral columns

## GEOMETRY 1



### *Import 1 (imp1)*

- 1 In the **Model Builder** window, under **Component 1 (comp1)** right-click **Geometry 1** and choose **Import**.
- 2 In the **Settings** window for **Import**, locate the **Source** section.
- 3 From the **Source** list, choose **Geometry sequence**.
- 4 From the **Geometry** list, choose **Work Plane 3 (wp3), Part 1**.
- 5 Click **Import**.

### *Distance Measurement 1 (dm1)*



- 1 In the **Geometry** toolbar, click  **Measurements** and choose **Distance Measurement**.  
Next, make some measurements to use when creating the axisymmetric geometry.
- 2 On the object **imp1(2)**, select Point 7 only.
- 3 In the **Settings** window for **Distance Measurement**, locate the **Geometric Entity Selection** section.
- 4 Click to select the  **Activate Selection** toggle button for **Second entity**.
- 5 On the object **imp1(2)**, select Point 3 only.

### *Distance Measurement 2 (dm2)*

- 1 In the **Geometry** toolbar, click  **Measurements** and choose **Distance Measurement**.
- 2 On the object **imp1(2)**, select Point 7 only.
- 3 In the **Settings** window for **Distance Measurement**, locate the **Geometric Entity Selection** section.
- 4 Click to select the  **Activate Selection** toggle button for **Second entity**.
- 5 On the object **imp1(2)**, select Point 8 only.

Now that the measures have been stored, delete the part.

### *Delete Entities 1 (dell)*



- 1 In the **Model Builder** window, right-click **Geometry 1** and choose **Delete Entities**.
- 2 In the **Settings** window for **Delete Entities**, locate the **Entities or Objects to Delete** section.
- 3 Click to select the  **Activate Selection** toggle button for **Selection**.
- 4 From the **Geometric entity level** list, choose **Object**.
- 5 Click the  **Select All** button in the **Graphics** toolbar.
- 6 Click  **Build Selected**.

Next, repeat the same procedure for another measurement.



#### *Import 2 (imp2)*

- 1 In the **Geometry** toolbar, click  **Import**.
- 2 In the **Settings** window for **Import**, locate the **Source** section.
- 3 From the **Source** list, choose **Geometry sequence**.
- 4 From the **Geometry** list, choose **Work Plane 2 (wp2), Part 1**.
- 5 Click **Import**.

#### *Distance Measurement 3 (dm3)*

- 1 In the **Geometry** toolbar, click  **Measurements** and choose **Distance Measurement**.
- 2 On the object **imp2(2)**, select Point 13 only.
- 3 In the **Settings** window for **Distance Measurement**, locate the **Geometric Entity Selection** section.
- 4 Click to select the  **Activate Selection** toggle button for **Second entity**.
- 5 On the object **imp2(2)**, select Point 6 only.

#### *Delete Entities 2 (del2)*

- 1 Right-click **Geometry 1** and choose **Delete Entities**.
- 2 In the **Settings** window for **Delete Entities**, locate the **Entities or Objects to Delete** section.
- 3 Click to select the  **Activate Selection** toggle button for **Selection**.
- 4 From the **Geometric entity level** list, choose **Object**.
- 5 Click the  **Select All** button in the **Graphics** toolbar.
- 6 Click  **Build Selected**.

Now import the last part and use the stored measures to finalize the 2D axisymmetric geometry.



#### *Import 3 (imp3)*

- 1 In the **Geometry** toolbar, click  **Import**.
- 2 In the **Settings** window for **Import**, locate the **Source** section.
- 3 From the **Source** list, choose **Geometry sequence**.
- 4 From the **Geometry** list, choose **Work Plane 1 (wp1), Part 1**.
- 5 Click **Import**.

### Rectangle 1 (r1)

- 1 In the **Geometry** toolbar, click  **Rectangle**.
- 2 In the **Settings** window for **Rectangle**, locate the **Size and Shape** section.
- 3 In the **Width** text field, type  $\sqrt{\text{external\_area}/\pi+(\text{geom1.dm3}/2)^2}$ .
- 4 In the **Height** text field, type  $0.0325+2*(\text{geom1.dm1}*\text{geom1.dm2})/\pi/(\text{geom1.dm3}/2)$ .
- 5 Locate the **Position** section. In the **z** text field, type  $-0.004-(\text{geom1.dm1}*\text{geom1.dm2})/\pi/(\text{geom1.dm3}/2)$ .



### Intersection 1 (int1)

- 1 In the **Geometry** toolbar, click  **Booleans and Partitions** and choose **Intersection**.
- 2 Click in the **Graphics** window and then press Ctrl+A to select both objects.
- 3 In the **Settings** window for **Intersection**, click  **Build Selected**.

### Circle 1 (c1)

- 1 In the **Geometry** toolbar, click  **Circle**.
- 2 In the **Settings** window for **Circle**, locate the **Size and Shape** section.
- 3 In the **Radius** text field, type 0.1.
- 4 Locate the **Position** section. In the **z** text field, type 0.01.
- 5 Locate the **Size and Shape** section. In the **Sector angle** text field, type 180.
- 6 Locate the **Rotation Angle** section. In the **Rotation** text field, type -90.

### Form Union (fin)

- 1 In the **Geometry** toolbar, click  **Build All**.
- 2 Click the  **Zoom Extents** button in the **Graphics** toolbar.

**3** In the **Model Builder** window, click **Form Union (fin)**.

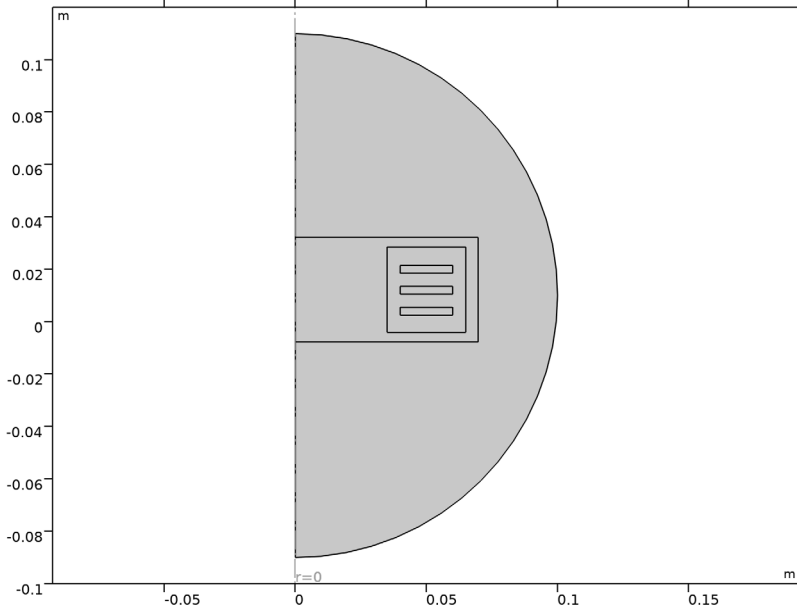

## MAGNETIC AND ELECTRIC FIELDS (MEF)

### *Ampère's Law and Current Conservation in Solids I*

- 1** In the **Physics** toolbar, click  **Domains** and choose **Ampère's Law and Current Conservation in Solids**.
- 2** Select Domain 2 only.
- 3** In the **Settings** window for **Ampère's Law and Current Conservation in Solids**, locate the **Constitutive Relation B-H** section.
- 4** From the **Magnetization model** list, choose **Magnetic losses**.

### *Magnetic Insulation I*

In the **Model Builder** window, click **Magnetic Insulation I**.

### *Electric Insulation I*

- 1** In the **Physics** toolbar, click  **Attributes** and choose **Electric Insulation**.
- 2** Click the  **Select All** button in the **Graphics** toolbar.

First add an Ampère's Law feature, which is necessary for adding the RLC Coil Group feature.

### *Ampère's Law 1*

- 1 In the **Physics** toolbar, click  **Domains** and choose **Ampère's Law**.
- 2 Select Domains 4–6 only.

Add the RLC Coil Group feature, which takes care of coupling the transverse currents inside the conductors to the capacitive current flowing perpendicularly to the windings.

### *RLC Coil Group 1*

- 1 In the **Physics** toolbar, click  **Domains** and choose **RLC Coil Group**.
- 2 Select Domains 4–6 only.

As the coils are connected from the bottom to the top and domain ordering is not the same, a manual ordering is necessary.

- 3 In the **Settings** window for **RLC Coil Group**, locate the **Geometry** section.
- 4 From the **Domain ordering** list, choose **Manual**.
- 5 Locate the **Domain Selection** section. In the list box, select **5**.
- 6 Locate the **Geometry** section. In the **Domain list** text field, type 5, 4, 6.

In order to improve variable scaling, set a ground voltage slightly different from zero.

- 7 Locate the **RLC Coil Group** section. In the  $V_0$  text field, type 1[mV].

## **MATERIALS**

Add material data for the copper windings and the lossy iron core.

### *Material 1 (mat1)*

- 1 In the **Model Builder** window, under **Component 1 (comp1)** right-click **Materials** and choose **Blank Material**.

2 Select Domain 2 only.

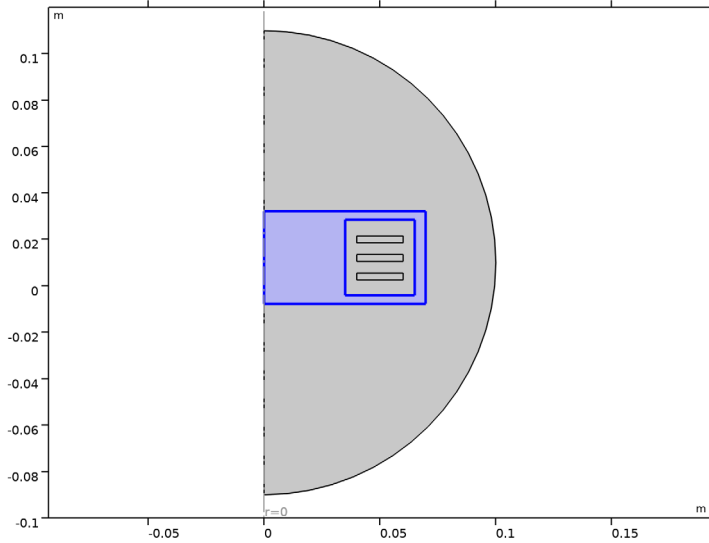

3 In the **Settings** window for **Material**, locate the **Material Contents** section.

4 In the table, enter the following settings:

Property	Variable	Value	Unit	Property group
Relative permeability (real part)	murPrim	1200		Magnetic losses
Relative permeability (imaginary part)	murBis	100		Magnetic losses
Electric conductivity	sigma_iso ; sigma_ii = sigma_iso, sigma_ij = 0	0	S/m	Basic
Relative permittivity	epsilon_r_iso ; epsilon_r_ii = epsilon_r_iso, epsilon_r_ij = 0	1		Basic

*Material 2 (mat2)*

1 Right-click **Materials** and choose **Blank Material**.

2 Select Domains 4–6 only.

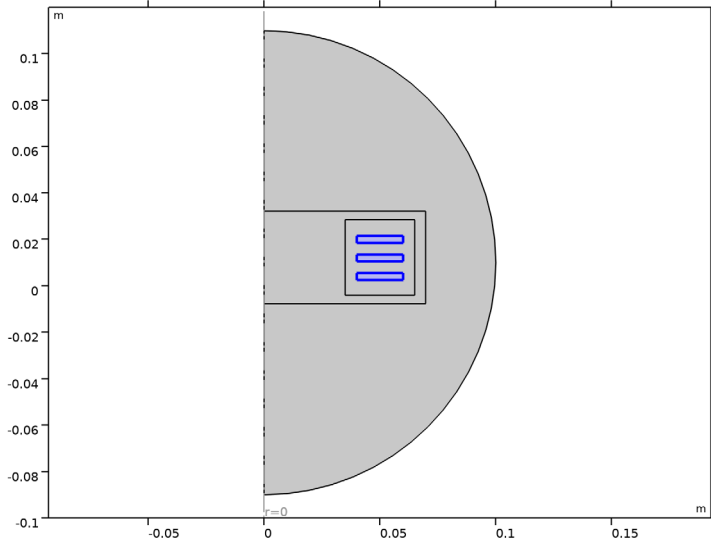

3 In the **Settings** window for **Material**, locate the **Material Contents** section.

4 In the table, enter the following settings:

Property	Variable	Value	Unit	Property group
Relative permeability	mur_iso ; murii = mur_iso, murij = 0	1		Basic
Electric conductivity	sigma_iso ; sigma_ii = sigma_iso, sigma_ij = 0	6e7	S/m	Basic
Relative permittivity	epsilon_r_iso ; epsilon_rii = epsilon_r_iso, epsilon_r_ij = 0	1		Basic

## MESH 1

*Free Triangular 1*

1 In the **Mesh** toolbar, click  **Free Triangular**.

2 In the **Settings** window for **Free Triangular**, locate the **Domain Selection** section.

- 3 From the **Geometric entity level** list, choose **Domain**.
- 4 Select Domains 2–6 only.

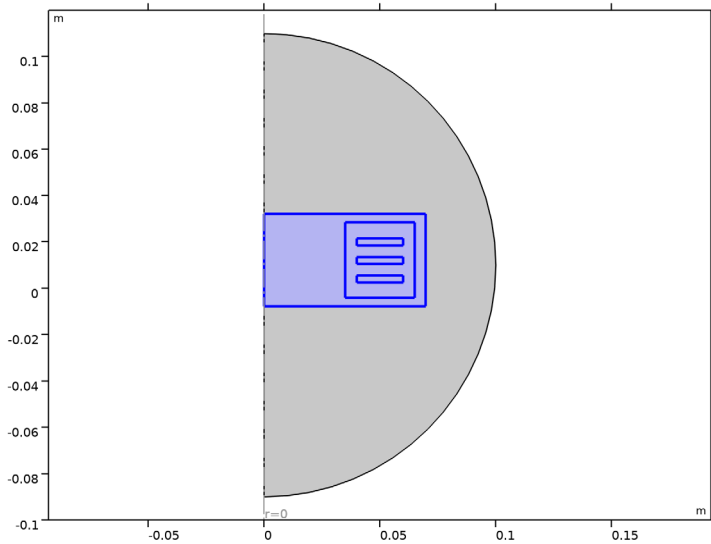

#### Size 1

- 1 Right-click **Free Triangular 1** and choose **Size**.
- 2 Select Domains 2 and 3 only.
- 3 In the **Settings** window for **Size**, locate the **Element Size** section.
- 4 Click the **Custom** button.
- 5 Locate the **Element Size Parameters** section.
- 6 Select the **Maximum element size** checkbox. In the associated text field, type  $2e-3$ .

#### Size 2

- 1 In the **Model Builder** window, right-click **Free Triangular 1** and choose **Size**.
- 2 In the **Settings** window for **Size**, locate the **Geometric Entity Selection** section.
- 3 Click  **Clear Selection**.
- 4 Select Domains 4–6 only.
- 5 Locate the **Element Size** section. Click the **Custom** button.
- 6 Locate the **Element Size Parameters** section.
- 7 Select the **Maximum element size** checkbox. In the associated text field, type  $5e-4$ .

### Free Triangular 2

- 1 In the **Mesh** toolbar, click  **Free Triangular**.
- 2 In the **Settings** window for **Free Triangular**, click  **Build Selected**.

### Boundary Layers 1

- 1 In the **Mesh** toolbar, click  **Boundary Layers**.
- 2 In the **Settings** window for **Boundary Layers**, locate the **Domain Selection** section.
- 3 From the **Geometric entity level** list, choose **Domain**.
- 4 Select Domains 4–6 only.

A boundary layer mesh is added in order to resolve the skin depth.

### Boundary Layer Properties

- 1 In the **Model Builder** window, click **Boundary Layer Properties**.
- 2 In the **Settings** window for **Boundary Layer Properties**, locate the **Boundary Selection** section.
- 3 From the **Selection** list, choose **All boundaries**.
- 4 Locate the **Layers** section. From the **Thickness specification** list, choose **First layer**.
- 5 In the **Number of layers** text field, type 12.
- 6 In the **Stretching factor** text field, type 1.3.
- 7 In the **Thickness** text field, type 10[um].
- 8 Click  **Build Selected**.

## STUDY 1

### Step 1: Frequency Domain

- 1 In the **Model Builder** window, under **Study 1** click **Step 1: Frequency Domain**.
- 2 In the **Settings** window for **Frequency Domain**, locate the **Study Settings** section.
- 3 From the **Frequency unit** list, choose **MHz**.
- 4 In the **Frequencies** text field, type range (1, 0.25, 10).
- 5 In the **Study** toolbar, click  **Compute**.

## RESULTS

### Magnetic Flux Density (mef)

Click the  **Zoom Extents** button in the **Graphics** toolbar.

*Study 1/Solution 1 (sol1)*

In the **Model Builder** window, expand the **Results** > **Datasets** node, then click **Study 1/Solution 1 (sol1)**.

*Selection*

- 1 In the **Results** toolbar, click  **Attributes** and choose **Selection**.
- 2 In the **Settings** window for **Selection**, locate the **Geometric Entity Selection** section.
- 3 From the **Geometric entity level** list, choose **Domain**.
- 4 Select Domains 2 and 4–6 only.

*Magnetic Flux Density, Revolved Geometry (mef)*

In the **Model Builder** window, under **Results** click **Magnetic Flux Density, Revolved Geometry (mef)**.

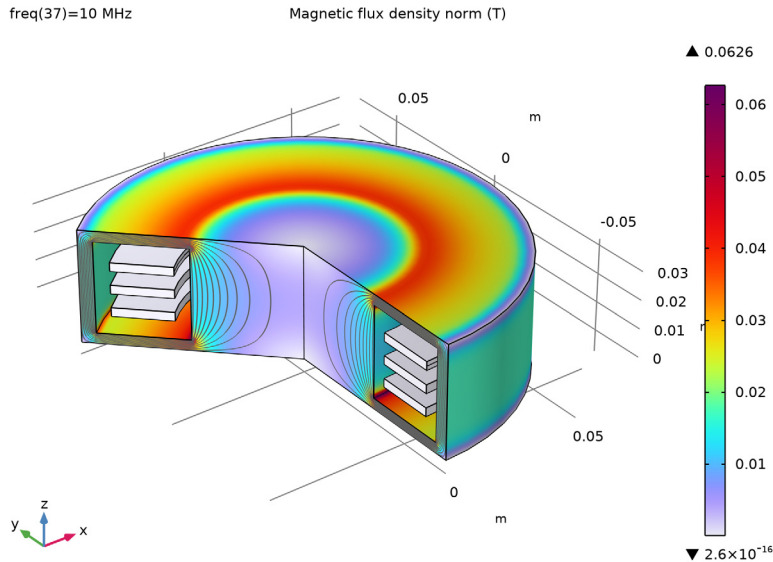

*Study 1/Solution 1 (2) (sol1)*

In the **Results** toolbar, click  **More Datasets** and choose **Solution**.

*Selection*



- 1 In the **Results** toolbar, click  **Attributes** and choose **Selection**.
- 2 In the **Settings** window for **Selection**, locate the **Geometric Entity Selection** section.
- 3 From the **Geometric entity level** list, choose **Domain**.

4 Select Domains 3–6 only.

#### Resistive Losses

- 1 In the **Results** toolbar, click  **2D Plot Group**.
- 2 In the **Settings** window for **2D Plot Group**, type Resistive Losses in the **Label** text field.
- 3 Locate the **Data** section. From the **Dataset** list, choose **Study 1/Solution 1 (2) (sol1)**.
- 4 From the **Parameter value (freq (MHz))** list, choose **1**.

#### Surface 1

- 1 Right-click **Resistive Losses** and choose **Surface**.
- 2 In the **Settings** window for **Surface**, locate the **Expression** section.
- 3 In the **Expression** text field, type  $\log(\text{mef}.\text{Qrh}+0.1)$ .
- 4 In the **Resistive Losses** toolbar, click  **Plot**.
- 5 Click the  **Zoom Extents** button in the **Graphics** toolbar.

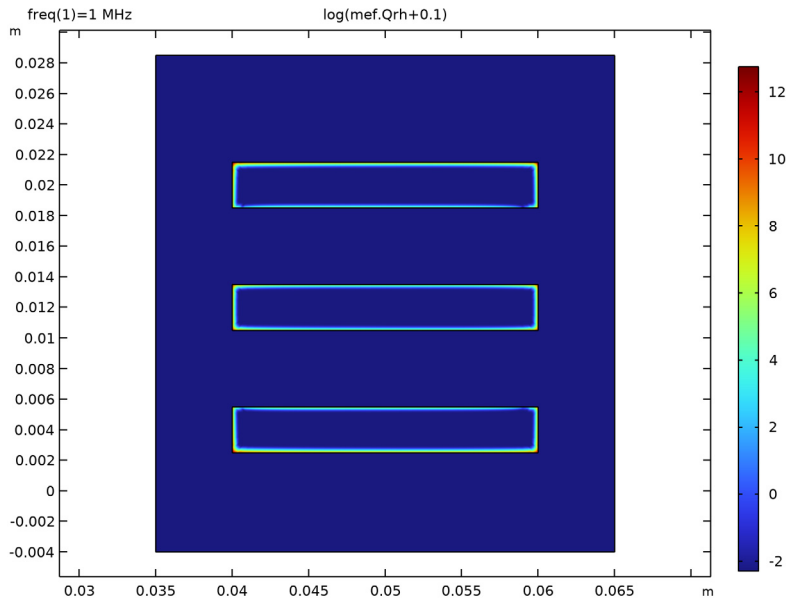



#### Electric Field

- 1 In the **Results** toolbar, click  **2D Plot Group**.
- 2 In the **Settings** window for **2D Plot Group**, type Electric Field in the **Label** text field.
- 3 Locate the **Data** section. From the **Dataset** list, choose **Study 1/Solution 1 (2) (sol1)**.

### *Arrow Surface 1*

- 1 Right-click **Electric Field** and choose **Arrow Surface**.
- 2 In the **Settings** window for **Arrow Surface**, locate the **Coloring and Style** section.
- 3 From the **Arrow length** list, choose **Normalized**.
- 4 From the **Arrow base** list, choose **Center**.
- 5 Set the slider value to **0.3**.
- 6 In the **Scale factor** text field, type  $3.0E-10$ .
- 7 Click the  **Zoom Extents** button in the **Graphics** toolbar.
- 8 Locate the **Arrow Positioning** section. Find the **r grid points** subsection. In the **Points** text field, type 20.
- 9 Find the **z grid points** subsection. In the **Points** text field, type 20.
- 10 Click **Replace Expression** in the upper-right corner of the **Expression** section. From the menu, choose **Component 1 (comp1) > Magnetic and Electric Fields > Electric > mef.Er, mef.Ez - Electric field**.

### *Color Expression 1*

- 1 Right-click **Arrow Surface 1** and choose **Color Expression**.
- 2 In the **Electric Field** toolbar, click  **Plot**.
- 3 Click the  **Zoom Extents** button in the **Graphics** toolbar.

4 In the **Model Builder** window, click **Color Expression 1**.

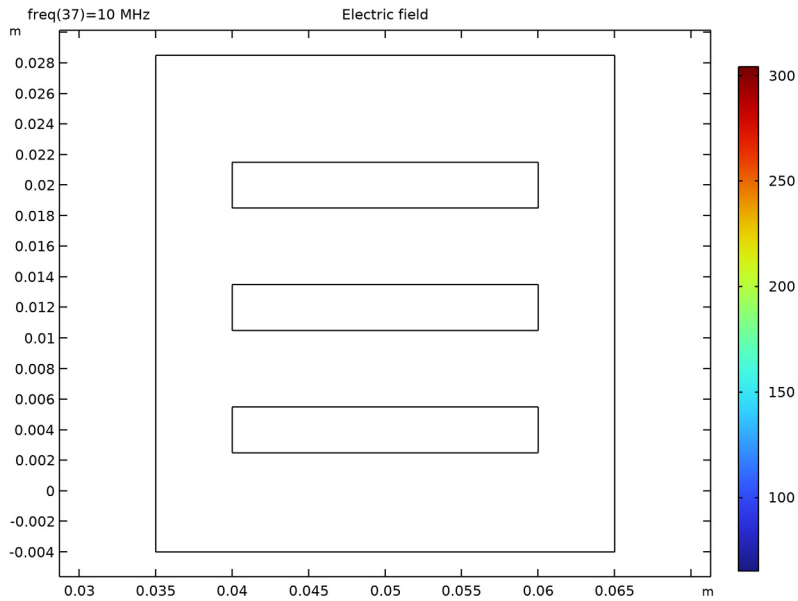

#### *Electric Field*

- 1 In the **Model Builder** window, under **Results** click **Electric Field**.
- 2 In the **Settings** window for **2D Plot Group**, locate the **Data** section.
- 3 From the **Parameter value (freq (MHz))** list, choose **6.25**.

4 In the **Electric Field** toolbar, click  **Plot**.

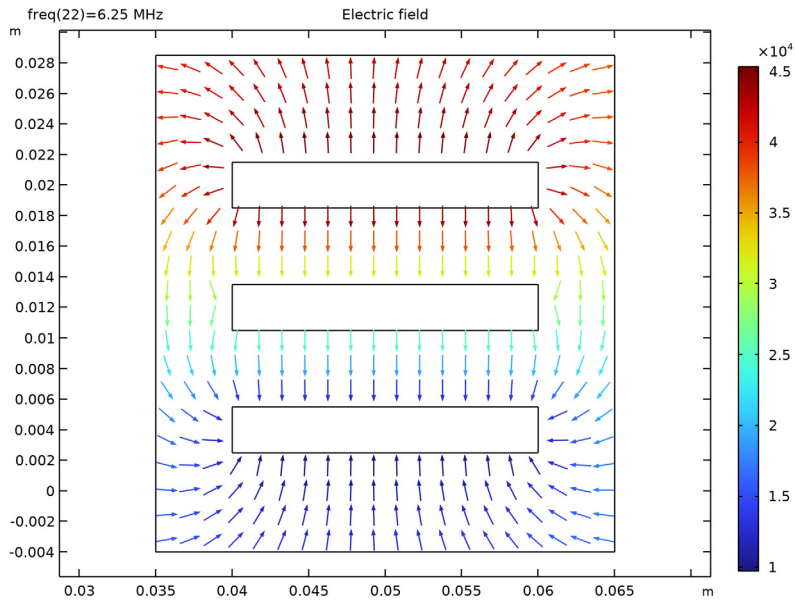

### Impedance

- 1 In the **Results** toolbar, click  **ID Plot Group**.
- 2 In the **Settings** window for **ID Plot Group**, type **Impedance** in the **Label** text field.
- 3 Click to expand the **Title** section. From the **Title type** list, choose **None**.
- 4 Locate the **Legend** section. From the **Position** list, choose **Upper left**.
- 5 Locate the **Plot Settings** section. Select the **Two y-axes** checkbox.

Generate a plot with the real and the imaginary part of the impedance, which can be read at low frequency as impedance and resistance. The resonant peak is clearly visible and compares well with the original 3D geometry.

### Global 1

Right-click **Impedance** and choose **Global**.

### Global 2

In the **Model Builder** window, right-click **Impedance** and choose **Global**.

### Global 1

1 In the **Settings** window for **Global**, locate the **y-Axis Data** section.



2 In the table, enter the following settings:

Expression	Unit	Description
mef.RCoil_1	$\Omega$	Real part of impedance

*Global 2*

- 1 In the **Model Builder** window, click **Global 2**.
- 2 In the **Settings** window for **Global**, locate the **y-Axis** section.
- 3 Select the **Plot on secondary y-axis** checkbox.
- 4 Locate the **y-Axis Data** section. In the table, enter the following settings:

Expression	Unit	Description
mef.XCoil_1	$\Omega$	Imaginary part of impedance

- 5 In the **Impedance** toolbar, click  **Plot**.
- 6 Click the  **Zoom Extents** button in the **Graphics** toolbar.

