

INTRODUCTION TO  
Microfluidics Module

# Introduction to the Microfluidics Module

© 1998–2025 COMSOL

Protected by patents listed on [www.comsol.com/patents](http://www.comsol.com/patents), or see Help > About COMSOL Multiphysics on the File menu in the COMSOL Desktop for less detailed lists of U.S. Patents that may apply. Patents pending.

This Documentation and the Programs described herein are furnished under the COMSOL Software License Agreement ([www.comsol.com/sla](http://www.comsol.com/sla)) and may be used or copied only under the terms of the license agreement.

COMSOL, the COMSOL logo, COMSOL Multiphysics, COMSOL Desktop, COMSOL Compiler, COMSOL Server, and LiveLink are either registered trademarks or trademarks of COMSOL AB. All other trademarks are the property of their respective owners, and COMSOL AB and its subsidiaries and products are not affiliated with, endorsed by, sponsored by, or supported by those trademark owners. For a list of such trademark owners, see [www.comsol.com/trademarks](http://www.comsol.com/trademarks).

Version: COMSOL 6.4

## Contact Information

Visit the Contact COMSOL page at [www.comsol.com/contact](http://www.comsol.com/contact) to submit general inquiries or search for an address and phone number. You can also visit the Worldwide Sales Offices page at [www.comsol.com/contact/offices](http://www.comsol.com/contact/offices) for address and contact information.

If you need to contact Support, an online request form is located on the COMSOL Access page at [www.comsol.com/support/case](http://www.comsol.com/support/case). Useful links:

- Support Center: [www.comsol.com/support](http://www.comsol.com/support)
- Product Download: [www.comsol.com/product-download](http://www.comsol.com/product-download)
- Product Updates: [www.comsol.com/product-update](http://www.comsol.com/product-update)
- COMSOL Blog: [www.comsol.com/blogs](http://www.comsol.com/blogs)
- Discussion Forum: [www.comsol.com/forum](http://www.comsol.com/forum)
- Events: [www.comsol.com/events](http://www.comsol.com/events)
- COMSOL Video Gallery: [www.comsol.com/videos](http://www.comsol.com/videos)
- Support Knowledge Base: [www.comsol.com/support/knowledgebase](http://www.comsol.com/support/knowledgebase)
- Learning Center: [www.comsol.com/support/learning-center](http://www.comsol.com/support/learning-center)

Part number: CM021902

# Contents

---

The Microfluidics Module . . . . .	5
Microfluidic Devices: Physics and Applications. . . . .	7
The Microfluidics Module Physics Interface Guide. . . . .	11
Physics Interface Guide by Space Dimension and Study Type . . .	16
Tutorial Model: A Controlled Diffusion Separator . . . . .	20



## The Microfluidics Module

---

The Microfluidics Module is used by engineers and scientists to understand, predict, and design microfluidic systems. The use of simulation tools in the design cycle is becoming more widespread as they can improve understanding, reduce prototyping costs, and speed up development. The Microfluidics Module allows users to quickly and accurately model single-phase flows, multiphase flows, flow through porous media, electrokinetic flows, and slightly rarefied gas flows.

The Microfluidics Module can solve stationary and time-dependent flows in two-dimensional and three-dimensional spaces. Formulations suitable for different types of flow are set up as predefined physics interfaces, referred to as Microfluidics physics interfaces. The Fluid Flow interfaces use physical quantities, such as pressure and flow rate, and physical properties, such as viscosity and density, to define a fluid-flow problem. Different physics interfaces are available to cover a range of microfluidic flows. Examples include: laminar flow, creeping flow, two-phase flow (phase field, level set, and moving mesh), three-phase flow (phase field), porous media flow (Darcy's Law, the Brinkman equations, Free and Porous Media Flow, Brinkman — which combines the Brinkman equations with laminar flow, or Free and Porous Media Flow, Darcy — which combines Darcy's Law with laminar flow) and slip flow. The transport of multiple species can also be treated with the Transport of Diluted Species interface. These physics interfaces can easily be coupled with, for example, the Electrostatics or Electric Currents interfaces in COMSOL Multiphysics to solve multiphysics problems such as electrokinetic flows.

For each of the Microfluidics physics interfaces, the underlying physical principles are expressed in the form of partial differential equations, together with corresponding initial and boundary conditions. COMSOL's design emphasizes the physics by providing users with the equations solved by each feature and offering the user full access to the underlying equation system. There is also tremendous flexibility to add user-defined equations and expressions to the system. For example, to model the transport of a species that significantly affects the viscosity of the fluid, simply type in a concentration-dependent viscosity — no scripting or coding is required (this is demonstrated in the [Tutorial Model: A Controlled Diffusion Separator](#)). When COMSOL Multiphysics compiles the equations, the complex couplings generated by these user-defined expressions are automatically included in the equation system. The equations are then solved using the finite element method and a range of industrial-strength solvers. Once a solution is obtained a vast range of postprocessing tools are available to interrogate the data, and predefined plots are automatically generated to show the device response. COMSOL Multiphysics offers the flexibility to evaluate a wide range of physical quantities including predefined quantities such as the pressure,

velocity, shear rate, or the vorticity (available through easy-to-use menus), as well as arbitrary user-defined expressions.

To model a microfluidic device, the geometry is first defined in the software. Then appropriate materials are selected and a suitable Microfluidics physics interface is added. Initial conditions and boundary conditions are set up within the physics interface. Next, the mesh is defined; in many cases the default mesh, which is produced from physics-dependent defaults, will be appropriate for the problem. A solver is selected, again with defaults appropriate for the relevant physics interface, and the problem is solved. Finally the results are visualized. All these steps are accessed from the COMSOL Desktop.

# Microfluidic Devices: Physics and Applications

---

Microfluidic flows occur on length scales that are orders of magnitude smaller than macroscopic flows. Manipulation of fluids at the microscale has a number of advantages; typically microfluidic systems are smaller, operate faster, and require less fluid than their macroscopic equivalents. Energy inputs and outputs are also easier to control (for example, heat generated in a chemical reaction) because the surface-to-area volume ratio of the system is much greater than that of a macroscopic system.

In general, as the length scale ( $L$ ) of the fluid flow is reduced, properties that scale with the surface area of the system become comparatively more important than those that scale with the volume of the flow. This is apparent in the fluid flow itself as the viscous forces, which are generated by shear over the isovelocity surfaces (scaling as  $L^2$ ), dominate over the inertial forces (which scale volumetrically as  $L^3$ ). The Reynolds number ( $Re$ ), which characterizes the ratio of these two forces, is typically low, so the flow is usually laminar ( $Re < 1000$ ). In many cases the creeping (Stokes) flow regime applies ( $Re \ll 1$ ). Laminar and creeping flows make mixing particularly difficult, so mass transport is often diffusion limited. The diffusion time scales as  $L^2$ , but even in microfluidic systems diffusion is often a slow process. This has implications for chemical transport within microfluidic systems. The figure below shows flow in a device designed to enhance the mixing of two fluids in a lamella flow. Pressure contours are shown on the walls of the mixer, and the velocity magnitude is shown at the inlets and outlets of the mixer as well as at the point where the two sets of channels (carrying different fluids) converge. Streamlines (in red) are also plotted. The inset shows the concentration of a diffusing species present in only one of the fluids. It is plotted along vertical lines located progressively further down the center of the mixer.

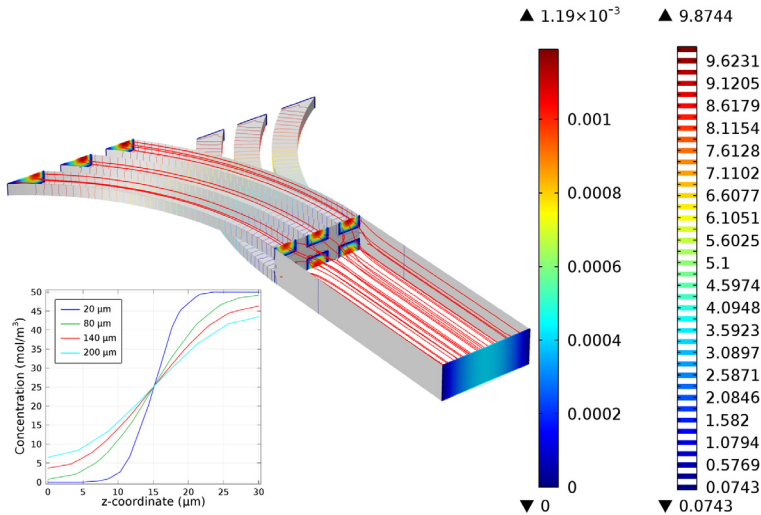

When multiple phases are present, surface tension effects become important relative to gravity and inertia at small length scales. The Laplace pressure (the pressure jump across a two phase boundary), capillary force, and Marangoni forces all scale as  $1/L$ . The figure below shows the break up of oil droplets to produce an emulsion as the oil flows into a channel carrying a second fluid. Velocity streamlines are shown and the fluid velocity is plotted on the symmetry plane. The two-phase boundary is shown in green.

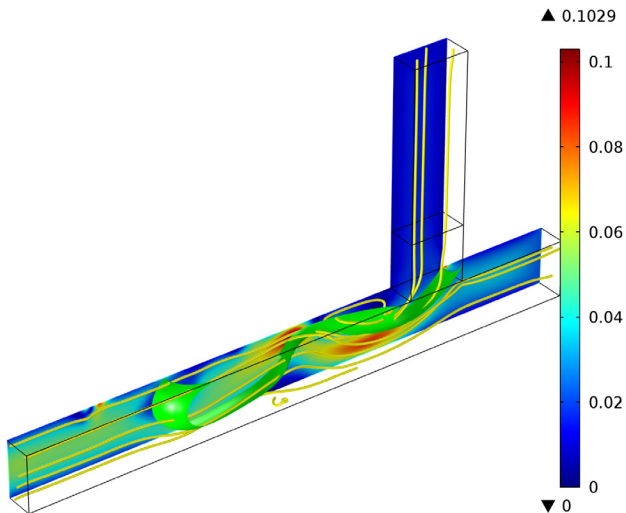

Flow through porous media can also occur on microscale geometries. Because the permeability of a porous media scales as  $L^2$  (where  $L$  is the average pore radius) the flow is often friction dominated when the pore size is in the micron range and Darcy's law can be used. For intermediate flows this module also provides a physics interface to model flows where the Brinkman equation is appropriate.

At the microscale, a range of electrohydrodynamic effects can be used to influence the fluid flow. The electric field strength for a given applied voltage scales as  $1/L$ , making it easier to apply relatively large fields to the fluid with moderate voltages. In electroosmosis the uncompensated ions in the charged electric double layer (EDL) present on the fluid surfaces are moved by an electric field, causing a net fluid flow. Electrophoretic and dielectrophoretic forces on charged or polarized particles in the fluid can be used to induce particle motion, as can diamagnetic forces in the case of magnetophoresis. The manipulation of contact angles by the electrowetting phenomena is also easy in microscale devices, a phenomenon that has been used as a basis for various new display technologies. The figure below shows an adjustable focus liquid lens, whose radius of curvature can be adjusted using the electrowetting effect. The colors show the fluid velocity magnitude in a lower, oil-filled part of the lens and the arrow plot shows the velocity in the liquid above the oil lens.

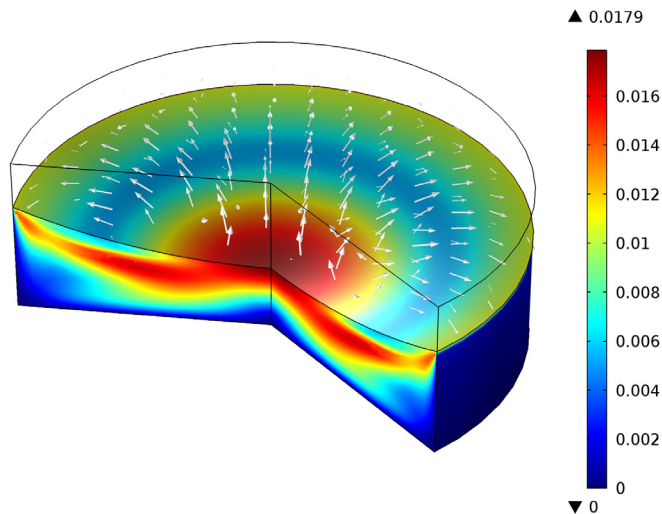

As the length scale of the flow becomes comparable to intermolecular length scale, more complex kinetic effects become important. For gases, the ratio of the molecular mean free path to the flow geometry size is given by the Knudsen number ( $Kn$ ). Clearly,  $Kn$  scales as  $1/L$ . For  $Kn < 0.01$ , fluid flow is usually well described by the Navier–Stokes equations with no-slip boundary conditions. In

the slip-flow regime ( $0.01 < \text{Kn} < 0.1$ ), appropriate slip boundary conditions can be used with the Navier–Stokes equations to describe the flow away from the boundary. The Microfluidics Module includes a physics interface to deal with these slightly rarefied gas flows: the Slip Flow interface. For more highly rarefied flows, the Molecular Flow Module should be used.

# The Microfluidics Module Physics Interface Guide

---

The Microfluidics physics interfaces are used to set up simulation problems. Each physics interface expresses the relevant physical phenomena in the form of sets of partial or ordinary differential equations, together with appropriate boundary and initial conditions. Each feature added to the physics interface represents a term or condition in the underlying equation set. These features are usually associated with a geometric entity within the model, such as a domain, boundary, edge (for 3D components), or point. [Figure 1](#) uses the Lamella Mixer model (found in the Microfluidics Module application library) to show the Model Builder and the Settings window for the selected Fluid Properties 1 feature node. This node adds the Navier–Stokes equations to the simulation within the domains selected. Under the Fluid Properties section the settings indicate that the fluid density and viscosity are inherited from the material properties assigned to the domain. The material properties can be set up as functions of dependent variables in the model, for example, temperature and pressure. The wall, inlet, symmetry, and outlet boundary conditions are also highlighted in the model tree. The Wall boundary condition is applied by default to all surfaces in the model and adds a no-slip constraint to the flow. The inlet and outlet features include a range of options to allow fluid to enter or leave the simulation domain.

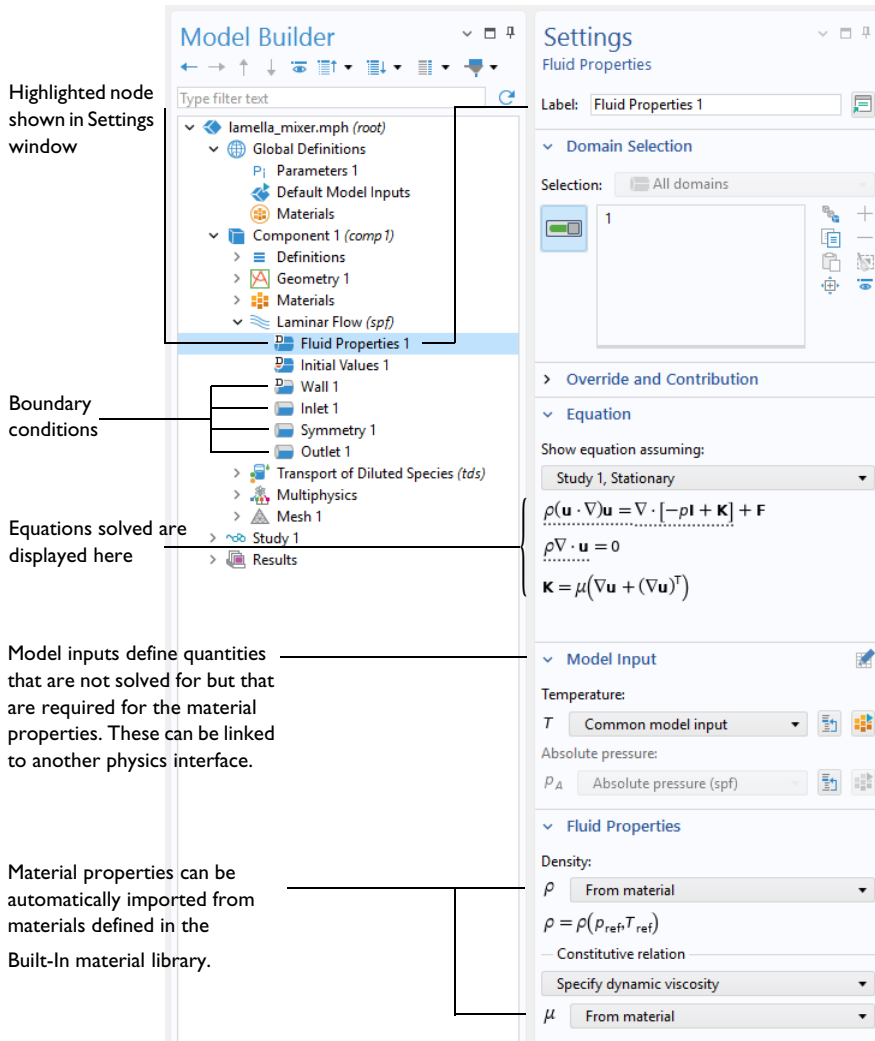

Figure 1: The Model Builder (to the left), and the Settings window for Fluid Properties I for the selected feature node (to the right). The Equation section in the Settings window shows the model equations. The terms added to the equation system by the feature are underlined with a dotted line.

The Microfluidics Module includes a number of physics interfaces for modeling different types of microfluidic devices. When a new model is started, these physics interfaces are selected from the Model Wizard. Figure 2 shows the Model Wizard with the physics interfaces included with the Microfluidics Module. Also see

Physics Interface Guide by Space Dimension and Study Type. Below, a brief overview of each of the Microfluidics Module physics interfaces is given.

- > AC/DC
- > Acoustics
- > Chemical Species Transport
    - Transport of Diluted Species (tds)
    - Transport of Diluted Species in Porous Media (tds)
  - > Reacting Flow
- > Fluid Flow
    - > Single-Phase Flow
      - Creeping Flow (spf)
      - Laminar Flow (spf)
      - Potential Flow
    - > Multiphase Flow
      - > Two-Phase Flow, Moving Mesh
      - > Two-Phase Flow, Level Set
      - > Two-Phase Flow, Phase Field
      - > Three-Phase Flow, Phase Field
    - > Porous Media and Subsurface Flow
      - Brinkman Equations (br)
      - Darcy's Law (dl)
      - Free and Porous Media Flow, Brinkman (fp)
      - Free and Porous Media Flow, Darcy
    - > Nonisothermal Flow
    - > Fluid-Structure Interaction
      - Fluid-Solid Interaction, Fixed Geometry
      - > Two-Phase Flow, Phase Field
    - > Rarefied Flow
      - Slip Flow (slpf)
  - > Heat Transfer
  - > Structural Mechanics
  - > Mathematics
    - > PDE Interfaces
    - > ODE and DAE Interfaces
    - > Optimization and Sensitivity
    - > Classical PDEs
    - > Moving Interface
      - Level Set (ls)
      - Level Set in Porous Media (ls)
      - Phase Field in Fluids (pf)
      - Ternary Phase Field (terpf)
    - > Deformed Mesh
    - > Wall Distance (wd)
    - > Curvilinear Coordinates (cc)

Figure 2: The Microfluidics Module physics interfaces as displayed in the Model Wizard. Note that this is for 3D components.

## SINGLE-PHASE FLOW

Microfluidic flows usually occur at low Reynolds numbers. The Reynolds number ( $Re$ ) is a measure of the ratio of the fluid viscous to the inertial forces acting on the fluid and is given by:  $Re = \rho UL/\mu$ , where  $\rho$  is the fluid density,  $U$  is a



characteristic velocity,  $L$  is a characteristic length scale, and  $\mu$  is the dynamic viscosity.

The Laminar Flow interface () applies when the Reynolds number is less than approximately 1000. The physics interface solves the Navier–Stokes equations, for incompressible, weakly compressible or compressible flows (for  $Ma < 0.3$ , where  $Ma = U/c$ , and  $c$  is the velocity of sound in the fluid). This Fluid Flow interface also allows for the simulation of non-Newtonian flows.

The Creeping Flow interface () approximates the Navier–Stokes equations for the case when the Reynolds number is significantly less than 1. This is often referred to as Stokes flow and is appropriate for use when viscous flow is dominant. It is usually applicable for microfluidic devices.

The Potential Flow interface () solves the equations for solenoidal and irrotational flow. Hydrostatic pressure is added as default in this module as this model will not account for losses. This physics interface can be used to get initial values for the Laminar Flow interface or for computing preliminary inviscid solutions.

## MULTIPHASE FLOW

The Two-Phase Flow, Level Set interface () , the Two-Phase Flow, Phase Field interface () , and the Two Phase Flow, Moving Mesh interface () are used to model two fluids separated by a fluid interface. The moving interface is tracked in detail using either the level set method, the phase field method, or by a moving mesh, respectively. The level set and phase field methods use a fixed mesh and solve additional equations to track the interface location. The moving mesh method solves the Navier–Stokes equations on a moving mesh with boundary conditions to represent the interface. In this case equations must be solved for the mesh deformation. Since a surface in the geometry is used to represent the interface between the two fluids in the Moving Mesh interface, the interface itself cannot break up into multiple disconnected surfaces. This means that the Moving Mesh interface cannot be applied to problems such as droplet formation in inkjet devices (in these applications the level set or phase field interfaces are appropriate). All three physics interfaces support both compressible (Mach number,  $Ma < 0.3$ ) and incompressible laminar flows, where one or both fluids can be non-Newtonian. Two-Phase Flow, Level Set also supports porous domains.

The Laminar Three-Phase Flow, Phase Field interface () models laminar flow of three incompressible phases which may be either Newtonian or non-Newtonian. The moving fluid–fluid interfaces between the three phases are tracked in detail using the phase–field method.

## POROUS MEDIA AND SUBSURFACE FLOW

The Brinkman Equations interface () models flow through a porous medium where shear stresses cannot be neglected. The physics interface supports both the Stokes-Brinkman formulation, suitable for very low flow velocities, and Forchheimer drag, which is used to account for effects at higher velocities. The fluid can be either incompressible or compressible, provided that the Mach number is less than 0.3.

The Darcy's Law interface () models relatively slow flows through porous media. Shear stresses perpendicular to the flow are neglected.

The Free and Porous Media Flow, Brinkman interface () models both porous media (using the Brinkman Equations) and laminar flow, automatically providing the coupling between them.

The Free and Porous Media Flow, Darcy interface () models both porous media (using Darcy's Law) and laminar flow, automatically providing the coupling between them.

These physics interfaces are appropriate for microfluidic porous media flow. Example applications include paper microfluidics and transport in biological tissue.

## FLUID-STRUCTURE INTERACTION

The Fluid-Structure Interaction interfaces () couple a Single-Phase Flow or Two-Phase Flow, Phase Field interface to a Solid Mechanics interface for studies of deformation induced by fluid forces.

## TRANSPORT OF DILUTED SPECIES

The Transport of Diluted Species interface () simulates chemical species transport through diffusion, convection (when coupled to fluid flow), and migration in electric fields for mixtures where one component, a solvent, is present in excess (90 mol% or greater). It is typically used to model the performance of mixers. For modeling chemical reactions in microfluidic devices the chemical reaction engineering module is recommended.

The Transport of Diluted Species in Porous Media interface () simulates chemical species transport in porous media.

The predefined multiphysics interface Laminar Flow, Diluted Species () under the Reacting Flow branch combines the functionality of the Laminar Flow and Transport of Diluted Species interfaces.

## RAREFIED GAS FLOWS

Rarefied gas flow occurs when the mean free path,  $\lambda$ , of the molecules becomes comparable with the length scale of the flow,  $L$ . The Knudsen number,  $\text{Kn} = \lambda/L$ , characterizes the importance of rarefaction effects on the flow. As the gas becomes rarefied (corresponding to increasing Knudsen number), the Knudsen layer, which is present within one mean free path of the wall, begins to have a significant effect on the flow. For Knudsen numbers below 0.01 rarefaction can be neglected, and the Navier Stokes equations can be solved with nonslip boundary conditions (the Laminar Flow (≡) or Creeping Flow (≡) interfaces can be used in this instance). For slightly rarefied gases ( $0.01 < \text{Kn} < 0.1$ ), the Knudsen layer can be modeled by appropriate boundary conditions at the walls together with the continuum Navier–Stokes equations in the domain. In this instance the Slip Flow interface (≡) is appropriate. To model higher Knudsen numbers the Molecular Flow Module is required. The figure below shows how high Knudsen numbers can be obtained either by reducing the size of the geometry, or by reducing the pressure or number density of the gas.

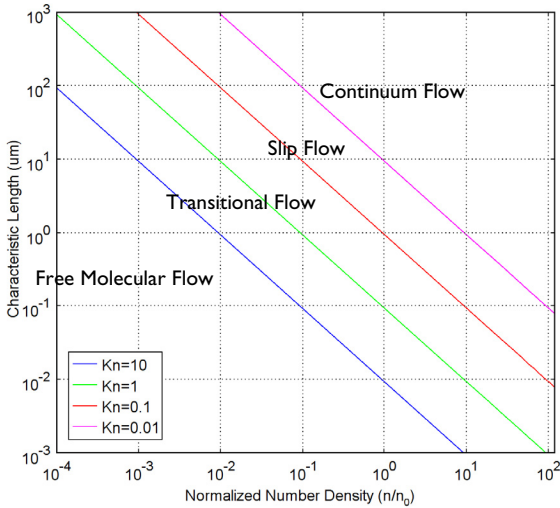





































Figure 3: Plot showing the main fluid flow regimes for rarefied gas flows. Different regimes are separated by lines of constant Knudsen number. The number density of the gas is normalized to the number density of an ideal gas at a pressure of 1 atmosphere and a temperature of 0° C ( $n_0$ ).

### Physics Interface Guide by Space Dimension and Study Type

The table below lists the physics interfaces available specifically with this module in addition to the COMSOL Multiphysics basic license.

PHYSICS INTERFACE	ICON	TAG	SPACE DIMENSION	AVAILABLE STUDY TYPE
 <b>Chemical Species Transport</b>				
Transport of Diluted Species <sup>1</sup>		tds	all dimensions	stationary; time dependent
Transport of Diluted Species in Porous Media		tds	all dimensions	stationary; time dependent
 <b>Reacting Flow</b>				
Laminar Flow, Diluted Species <sup>1</sup>		—	3D, 2D, 2D axisymmetric	stationary; time dependent
 <b>Fluid Flow</b>				
 <b>Single-Phase Flow</b>				
Creeping Flow		spf	3D, 2D, 2D axisymmetric	stationary; time dependent
Laminar Flow <sup>1</sup>		spf	3D, 2D, 2D axisymmetric	stationary; time dependent
 <b>Potential Flow</b>				
Incompressible Potential Flow		ipf	3D, 2D, 2D axisymmetric	stationary
 <b>Multiphase Flow</b>				
 <b>Two-Phase Flow, Moving Mesh</b>				
Laminar Two-Phase Flow, Moving Mesh		—	3D, 2D, 2D axisymmetric	time dependent
 <b>Two-Phase Flow, Level Set</b>				
Laminar Two-Phase Flow, Level Set		—	3D, 2D, 2D axisymmetric	time dependent with phase initialization

PHYSICS INTERFACE	ICON	TAG	SPACE DIMENSION	AVAILABLE STUDY TYPE
 <b>Two-Phase Flow, Phase Field</b>				
Laminar Two-Phase Flow, Phase Field		—	3D, 2D, 2D axisymmetric	time dependent with phase initialization
 <b>Three-Phase Flow, Phase Field</b>				
Laminar, Three-Phase Flow, Phase Field		—	3D, 2D, 2D axisymmetric	time dependent with phase initialization
 <b>Porous Media and Subsurface Flow</b>				
Brinkman Equations		br	3D, 2D, 2D axisymmetric	stationary; time dependent
Darcy's Law		dl	all dimensions	stationary; time dependent
Free and Porous Media Flow, Brinkman		fp	3D, 2D, 2D axisymmetric	stationary; time dependent
Free and Porous Media Flow, Darcy		—	3D, 2D, 2D axisymmetric	stationary; time dependent
 <b>Fluid-Structure Interaction</b>				
Fluid-Solid Interaction, Fixed Geometry <sup>2</sup>		—	3D, 2D, 2D axisymmetric	stationary; stationary, one way; time dependent; time dependent, one way
Fluid-Solid Interaction, Two-Phase Flow, Phase Field, Fixed Geometry <sup>2</sup>		—	3D, 2D, 2D axisymmetric	time dependent; time dependent with phase initialization
 <b>Rarefied Flow</b>				
Slip Flow		slpf	3D, 2D, 2D axisymmetric	stationary; time dependent

PHYSICS INTERFACE	ICON	TAG	SPACE DIMENSION	AVAILABLE STUDY TYPE
<b>Δu Mathematics</b>				
<b> Moving Interface</b>				
Level Set		ls	all dimensions	time dependent with phase initialization
Level Set in Porous Media		ls	all dimensions	time dependent with phase initialization
Phase Field in Fluids		pf	all dimensions	time dependent; time dependent with phase initialization
Ternary Phase Field		terpf	3D, 2D, 2D axisymmetric	time dependent
<sup>1</sup> This physics interface is included with the core COMSOL Multiphysics software but has added functionality for this module.				

# Tutorial Model: A Controlled Diffusion Separator<sup>1</sup>

---

This example treats an H-shaped microfluidic device for separation through diffusion. The device puts two different laminar streams in contact for a controlled period of time. The contact surface is well defined, and by controlling the flow rate it is possible to control the amount of species transported from one stream to the other through diffusion. The device concept is illustrated in Figure 4. The design aims to maintain a laminar flow field when the two streams, A and B, are united and thus prevent uncontrolled convective mixing. The transport of species between streams A and B should take place only by diffusion in order that species with low diffusion coefficients stay in their respective streams. In this way, light species with high diffusivity can be separated from heavy species with low diffusivity. Let us look at a mixture of light and heavy species entering through inlet A. If the separator is properly designed, the heavy species should exit almost exclusively through outlet A. The lighter species should exit through both outlet A and B in equal rates. In this way, outlet B contains only the lighter species.

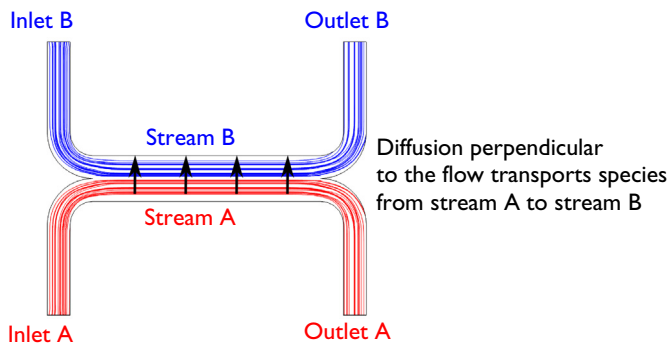

Figure 4: Device concept.

The flow rate at the inlet is approximately 0.1 mm/s. The Reynolds number, which is important for characterizing the flow, is given by:

$$Re = \frac{\rho UL}{\mu} = 0.001$$

---

1. This example was originally formulated by Albert Witarsa under Professor Bruce Finlayson's supervision at the University of Washington in Seattle. It was part of a graduate course in which the assignment consisted of using mathematical modeling to evaluate the potential of patents in the field of microfluidics.

where  $\rho$  is the fluid density ( $1000 \text{ kg/m}^3$ ),  $U$  is a characteristic velocity of the flow ( $0.1 \text{ mm/s}$ ),  $\mu$  is the fluid viscosity ( $1 \text{ mPa}\cdot\text{s}$ ), and  $L$  is a characteristic dimension of the device ( $10 \text{ }\mu\text{m}$ ). When the Reynolds number is significantly less than 1, as in this example, the Creeping Flow interface can be used. The problematic convective term in the Navier–Stokes equations can be dropped, leaving the incompressible Stokes equations:

$$\begin{aligned}\nabla \cdot (-p\mathbf{I} + \mu(\nabla\mathbf{u} + (\nabla\mathbf{u})^T)) &= 0 \\ \nabla \cdot \mathbf{u} &= 0\end{aligned}$$

where  $\mathbf{u}$  is the local velocity (m/s) and  $p$  is the pressure (Pa).

Mixing in the device involves species at relatively low concentrations compared to the solvent, in this case water. This means that the solute molecules interact only with water molecules, and Fick’s law can be used to describe the diffusive transport. The mass-balance equation for the solute is therefore:

$$-\nabla \cdot (-D\nabla c + c\mathbf{u}) = 0 \quad (1)$$

where  $D$  is the diffusion coefficient of the solute ( $\text{m}^2/\text{s}$ ) and  $c$  is its concentration ( $\text{mol}/\text{m}^3$ ). Diffusive flows can be characterized by another dimensionless number: the Peclet number, which is given by:

$$\text{Pe} = \frac{LU}{D}$$

In this example, the parametric solver is used to solve Equation 1 for three different species, each with different values of  $D$ :  $1 \times 10^{-11} \text{ m}^2/\text{s}$ ,  $5 \times 10^{-11} \text{ m}^2/\text{s}$ , and  $1 \times 10^{-10} \text{ m}^2/\text{s}$ . These values of  $D$  correspond to Peclet numbers of 100, 20, and 10, respectively. Since these Peclet numbers are all greater than 1, numerical stabilization is required when solving Fick’s equation. COMSOL Multiphysics includes the stabilization by default, so no explicit settings are required.

The example is solved with two versions:

- In the first version, it is assumed that a change in solute concentration does not influence the fluid’s density and viscosity. This implies that it is possible to first solve the Navier–Stokes equations and then solve the mass balance equation.
- In the second version, the viscosity depends quadratically on the concentration

$$\mu = \mu_0(1 + \alpha c^2)$$

Here  $\alpha$  is a constant of dimension  $\text{m}^6/(\text{mol})^2$  and  $\mu_0$  is the viscosity at zero concentration. Such a relationship between concentration and viscosity is usually observed in solutions of larger molecules.

The geometry of the device is shown in Figure 5. The device geometry is split in two because of symmetry.

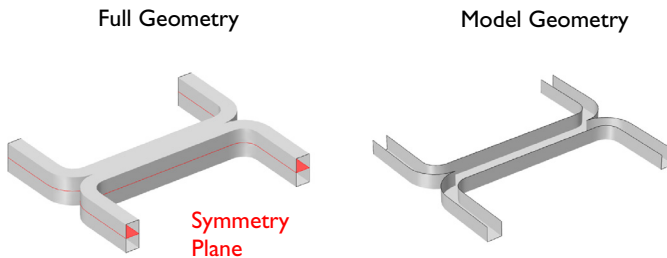



Figure 5: Left: Device geometry showing symmetry plane. Right: Model geometry. Only half of the device needs to be simulated, as the flow is symmetric about the midplane.

## Model Wizard









---

**Note:** These instructions are for the user interface on Windows but apply, with minor differences, also to Linux and Mac.

1 To start the software, double-click the COMSOL icon on the desktop. When the software opens, you can choose to use the Model Wizard to create a new COMSOL Multiphysics model or Blank Model to create one manually. For this tutorial, click the Model Wizard button.

If COMSOL Multiphysics is already open, you can start the Model Wizard by selecting New  from the File menu and then click Model Wizard .

The Model Wizard guides you through the first steps of setting up a model. The next window lets you select the dimension of the modeling space.

- 2 In the Select Space Dimension window, click the 3D button .
- 3 In the Select Physics tree, under Fluid Flow  > Single-Phase Flow  click Creeping Flow (spf) .
- 4 Click Add.
- 5 In the Select Physics tree, under Chemical Species Transport  click Transport of Diluted Species (tds) .
- 6 Click Add and then the Study button .
- 7 In the tree, under General Studies click Stationary .
- 8 Click Done .

## Geometry 1



---

For many microfluidic devices it is convenient to specify the geometry dimensions using micrometers. Since the device is symmetric, it is only necessary to model half of it.



- 1 In the Model Builder window, under Component 1 click Geometry 1 .
- 2 In the Settings window for Geometry, locate the Units section. From the Length unit list, choose  $\mu\text{m}$ .

The geometry can be constructed by extruding a 2D work plane. First draw a top down view of the structure in the work plane.



### Work Plane 1

- 1 In the Geometry toolbar, click Work Plane .
- 2 In the Settings window for Work Plane, click Go to Plane Geometry .
- 3 In the Model Builder window, click Plane Geometry .



### Rectangle 1



- 1 Right-click Plane Geometry  and choose Rectangle .
- 2 In the Settings window for Rectangle, locate the Size and Shape section.
  - In the Width text field, type 140.
  - In the Height text field, type 60.
- 3 Click the Build Selected button .

### Rectangle 2





- 1 Right-click Plane Geometry  and choose Rectangle .
- 2 In the Settings window for Rectangle locate the Size and Shape section.
  - In the Width text field, enter 120.
  - In the Height text field, enter 50.
- 3 Locate the Position section.
  - In the xw text field, enter 10.
  - In the yw text field, enter 10.
- 4 Click the Build Selected button .

### Difference 1



- 1 Right-click Plane Geometry  and choose Booleans and Partitions > Difference .
- 2 In the Settings window for Difference, locate the Difference section.

- 3 In Objects to add, select the object r1 only.
- 4 In the Settings window for Difference, locate the Difference section. Under Objects to subtract, toggle the Activate Selection button  .
- 5 Select the object r2 only.
- 6 Click the Build Selected button  .



#### Fillet 1

- 1 Right-click Plane Geometry  and choose Fillet  .
- 2 On the object dif1, select Points 3 and 5 only.  
It might be easier to select the correct points by using the Selection List window. To open this window, in the Home toolbar click Windows and choose Selection List. (If you are running the cross-platform desktop, you find Windows in the main menu). You can also click the Paste Selection button  and enter the information in the Selection text field. For more information about selecting geometric entities in the Graphics window, see the *COMSOL Multiphysics Reference Manual*.
- 3 In the Settings window for Fillet, locate the Radius section. In the Radius text field, type 10.
- 4 Click the Build Selected button  .





#### Fillet 2

- 1 Right-click Plane Geometry  and choose Fillet  .
- 2 On the object fil1, select Points 1 and 9 only.
- 3 In the Settings window for Fillet locate the Radius section. In the Radius text field, enter 20.
- 4 Click the Build Selected button  .

#### Mirror 1



- 1 Right-click Plane Geometry  and choose Transforms  > Mirror.
- 2 Select the object fil2 only.
- 3 In the Settings window for Mirror, locate the Input section. Select the Keep input objects checkbox.
- 4 Locate the Normal Vector to Line of Reflection section.
  - In the xw text field, type 0.
  - In the yw text field, type 1.
- 5 Click the Build Selected button  .

### Union 1



- 1 Right-click Plane Geometry  and choose Booleans and Partitions  > Union .
- 2 Click in the Graphics window and then press Ctrl+A to select both objects.
- 3 Click the Build Selected button .

### Extrude 1

Extrude the 2D geometry to create a 3D geometry.

- 1 Right-click Work Plane 1  and choose Extrude .
- 2 In the Settings window for Extrude, locate the Distances section.
- 3 In the table, enter the following settings:

DISTANCES ( $\mu\text{m}$ )
10

- 4 Click the Build Selected button .
- 5 Click the Zoom Extents button  in the Graphics toolbar.

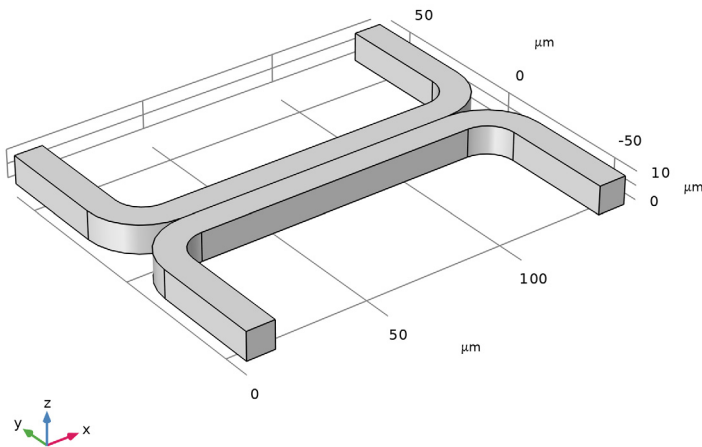

## Global Definitions

---

Create parameters to define the model.

## Parameters



- 1 In the model builder window, under Global Definitions, click Parameters 1 .
- 2 In the Settings window for Parameters, locate the Parameters section.
- 3 In the table, enter the following settings:

NAME	EXPRESSION	VALUE	DESCRIPTION
D	$5e-11[m^2/s]$	5E-11 m <sup>2</sup> /s	Diffusion constant
fr	15[p1/s]	1.5E-14 m <sup>3</sup> /s	Inlet flow rate
c0	1[mol/m <sup>3</sup> ]	1 mol/m <sup>3</sup>	Inlet concentration
alpha	$0.5[(m^3/mol)^2]$	0.5 m <sup>6</sup> /mol <sup>2</sup>	Viscosity c <sup>2</sup> -term prefactor

## Materials

Add material properties to the model.

### Material 1



- 1 In the Model Builder window, under Component 1(comp 1), right-click Materials  and choose Blank Material .
- 2 In the Settings window for Material, locate the Material Contents section.
- 3 In the table, enter the following settings:

PROPERTY	VARIABLE	VALUE	UNIT	PROPERTY GROUP
Density	rho	1000	kg/m <sup>3</sup>	Basic
Dynamic viscosity	mu	1e-3	Pa·s	Basic

## Multiphysics

Use the Reacting Flow, Diluted Species multiphysics coupling to couple the velocity.

### Reacting Flow, Diluted Species 1 (rfd1)

In the Physics toolbar, click Multiphysics  and choose Domain > Reacting Flow, Diluted Species .

## Creeping Flow

---

**Note:** There are several methods to select a geometric entity. To select, for example, a boundary, place the cursor over the boundary in the graphics window. If the required boundary is not highlighted in red then rotate the scroll wheel until it is highlighted, then left-click to select it (the up and down arrow keys can also be used instead of the scroll wheel). Alternatively, use the Selection list to display a list of the available boundary numbers (available from the Home > Windows menu if you are using windows, or from the Windows menu on other platforms). For more information about selecting geometric entities in the Graphics window, see the *COMSOL Multiphysics Reference Manual*.

1 In the Model Builder, under Component 1 click Creeping Flow .

**Note:** Several default nodes are added automatically to the model tree. The  'D' in the upper left corner of the node indicates these are default nodes.

### *Inlet 1*

Add a fully developed flow inlet boundary condition.

- 1 In the Physics toolbar, click Boundaries  and choose Inlet.
- 2 Select Boundary 2 and 10 only.
- 3 In the Settings window for Inlet, locate the Boundary Condition section. From the Boundary condition list, choose Fully developed flow.
- 4 Locate the Fully developed flow section. Click the Flow rate button.
  - In the  $V_0$  text field, type  $r/2$ .  
The flow rate is set to one half of the parameter value, since only half of the geometry is modeled.

### *Outlet 1*

Add an outlet with a pressure boundary condition.

- 1 In the Physics toolbar, click Boundaries  and choose Outlet.
- 2 Select Boundaries 23 and 25 only.  
The default pressure of 0 Pa is appropriate in this case.

### *Symmetry 1*

Add a symmetry boundary condition in the symmetry plane.

- 1 In the Physics toolbar, click Boundaries  and choose Symmetry.

2 Select Boundaries 4 and 9 only.

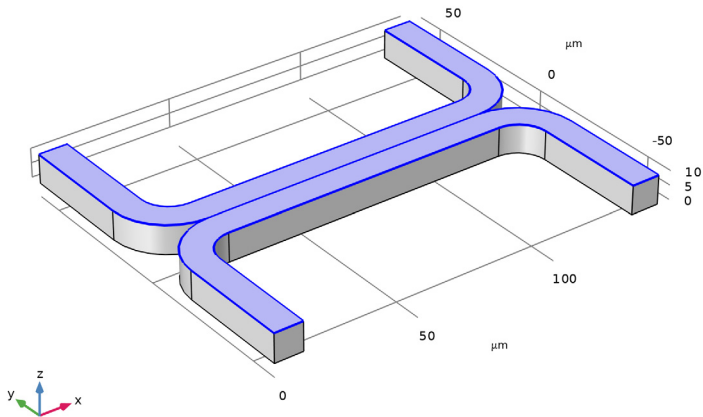

## Transport of Diluted Species

---

Now set up the mass transport physics features.

### *Transport of Diluted Species (tds)*

Start by raising the element order to quadratic in order to match the discretization for the velocity. The default discretization for Creeping Flow is P2+P1.

- 1 In the Model Builder, under Component 1 click Transport of Diluted Species (tds).
- 2 In the Settings window for Transport of Diluted Species, click to expand the Discretization section.
- 3 From the Concentration list, choose Quadratic.

### *Transport Properties 1*

The diffusion coefficient is set to use the parameter previously defined.

- 1 In the Model Builder, under Component 1 > Transport of Diluted Species (tds) node click Fluid 1.
- 2 Locate the Diffusion section. In the  $D_c$  text field, enter D.

Note that the velocity field for the species convection is controlled by the Reacting Flow, Diluted Species multiphysics coupling.

### *Concentration 1*

Specify the concentration at the two inlets.



- 1 In the Physics toolbar, click Boundaries  and choose Concentration.
- 2 Select Boundary 2 only.
- 3 In the Settings window for Concentration, locate the Concentration section. Select the Species c checkbox.
- 4 In the  $c_{0,c}$  text field, enter  $c_0$ .

### *Concentration 2*



- 1 In the Physics toolbar, click Boundaries  and choose Concentration.
- 2 Select Boundary 10 only.
- 3 In the Settings window for Concentration, locate the Concentration section. Select the Species c checkbox.  
In this case the concentration should take the default value of 0.

### *Outflow 1*

Use the outflow condition to allow species to leave the domain by convection. Since we will ultimately be interested in the weighted average concentration, add two Outflow features, each of which will provide its own value.

- 1 In the Physics toolbar click Boundaries  and choose Outflow.
- 2 In the Settings window for Outflow, locate the Boundary Selection section.
- 3 Click Paste Selection .
- 4 In the Paste Selection dialog, type 23 in the Selection text field.
- 5 Click OK.

### *Outflow 2*



- 1 In the Physics toolbar click Boundaries  and choose Outflow.
- 2 In the Settings window for Outflow, locate the Boundary Selection section.
- 3 Click Paste Selection .
- 4 In the Paste Selection dialog, type 25 in the Selection text field.
- 5 Click OK.

## Mesh 1

---

Set up the mesh. By default, COMSOL Multiphysics will create a mesh for the physics currently in the model. Often this is good enough, but in this case, we want to make some small edits to the default mesh sequence. By default, the fine mesh is not applied to interior boundaries. Typically this is wanted, since interior boundaries are transparent to the fluid flow. However, in this case, the mixing of the two streams occurs close to this interior boundary, so we can add boundary 16, in the middle of the channel, to the Size 1 selection and also to the Boundary Layer Properties 1 mesh feature.





### Size

- 1 In the Model Builder window, under Component 1 click Mesh 1 .
- 2 In the Settings window for Mesh, locate the Physics-Controlled Mesh section.
- 3 From the Element Size list, choose Coarse.
- 4 Right-click Mesh 1  and choose Edit Physics-Induced Sequence.

### Size 2

- 1 In the Model Builder window, under Component 1 (comp1) > Mesh 1 click Size 2.
- 2 In the Settings window for Size, locate the Geometric Entity Selection section.
- 3 Click Paste Selection .
- 4 In the Paste Selection dialog, type 16 in the Selection text field.
- 5 Click OK.

### Boundary Layer Properties 1

- 1 In the Model Builder window, expand the Component 1 (comp1) > Mesh 1 > Boundary Layers 1  node, then click Boundary Layer Properties 1 .
- 2 In the Settings window for Boundary Layer Properties, locate the Boundary Selection section.
- 3 Click Paste Selection .
- 4 In the Paste Selection dialog, type 16 in the Selection text field.
- 5 Click OK.
- 6 Right-click Component 1 (comp1) > Mesh 1 > Boundary Layers 1 > Boundary Layer Properties 1 and choose Build All .

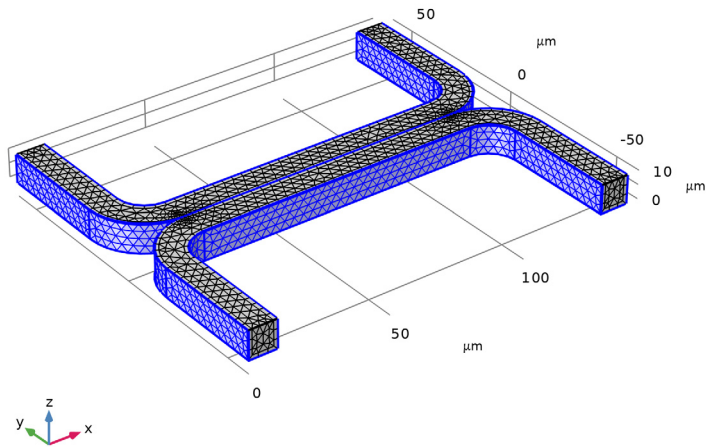

## Study 1

---

Now set up a study to solve the problem. Initially it is assumed that the fluid flow and diffusion problems are uncoupled. In this case it makes sense to solve the fluid flow problem first and then to use the velocity field as an input for the diffusion problem. This will save time and memory, particularly since the diffusion problem is solved for three parameters.

- 1 In the Model Builder window, click Study 1 .
- 2 In the Settings window for Study, locate the Study Settings section. Clear the Generate default plots checkbox.

Since the study automatically generates a large number of default plots, default plots are disabled.

For Step 1, solve only the creeping flow problem.



### *Step 1: Stationary*

- 1 In the Model Builder window, under Study 1 click Step 1: Stationary .
- 2 In the Settings window for Stationary, locate the Physics and Variables Selection section.

- In the table, clear the Solve for checkbox for Transport of Diluted Species row in the Physics interface column. Click to change the check mark  to , to remove the physics interface from Step 1: Stationary.

Add a second study step.

### Step 2: Stationary 2

- In the Study toolbar, click Study Steps  and choose Stationary > Stationary .
- Disable the solution of the creeping flow problem for this step.
- In the Settings window for Stationary, locate the Physics and Variables Selection section.
- In the table, clear the Solve for checkbox for Creeping Flow. Click to change the check mark  to , to remove the physics interface from Step 2: Stationary 2.
- Solve the diffusion problem for three values of the diffusion coefficient.
- In the Settings window for Stationary, click to expand the Study Extensions section. Select the Auxiliary Sweep checkbox.
- Click Add .
- In the table, enter the following settings:

PARAMETER NAME	PARAMETER VALUE LIST	PARAMETER UNIT
D (Diffusion constant)	1e-10 5e-11 1e-11	m <sup>2</sup> /s



- In the Home toolbar click Compute. .

## Results

---

### Datasets

Create a surface dataset to view the pressure on the channel walls.

- In the Results toolbar, click More Datasets  and choose Surface .
- In the Settings window for Surface, locate the Selection section. Click Paste Selection .
- In the Paste Selection dialog, type 1 3 5 6 7 8 11 12 13 14 15 17 18 19 20 21 22 24 26 27 in the Selection text field.
- Click OK.



### *Velocity (Uncoupled Flow)*

First plot the velocity of the flow within the channel.

- 1 In the Results toolbar, click 3D Plot Group .
- 2 In the Settings window for 3D Plot Group, type *Velocity (Uncoupled Flow)* in the Label text field.



### *Slice 1*

Use a slice plot to view the data on one or more slices through the geometry.

- 1 In the Model Builder window, right-click *Velocity (Uncoupled Flow)*  and choose *Slice* .
- 2 In the Settings window for *Slice*, locate the Expression section. From the Unit list, choose *mm/s*.

### *Slice 2*

Add additional slices in different directions.



- 1 Right-click *Velocity (Uncoupled Flow)*  and choose *Slice* .
- 2 In the Settings window for *Slice*, locate the Expression section. From the Unit list, choose *mm/s*.
- 3 Locate the Plane Data section.
  - From the Plane list, choose *xy-planes*.
  - In the Planes text field, type *1*.

The extra slices should use the same scale and colors for the velocity plot as the existing slice.

- 4 Click to expand the *Inherit Style* section. From the Plot list choose *Slice 1*. To avoid duplicate titles, turn off the title for additional slices.
- 5 Click to expand the *Title* section. From the Title type list, choose *None*.

### *Slice 3*

Add slices in a third plane.

- 1 Under *Velocity (Uncoupled Flow)* , right-click *Slice 2*  and choose *Duplicate* .
- 2 In the Settings window for *Slice*, locate the Plane Data section.
  - From the Plane list, choose *zx-planes*.
  - In the Planes text field, enter *2*.

### *Arrow Volume 1*

Use the arrow volume plot to visualize the flow direction.

- 1 Right-click *Velocity (Uncoupled Flow)*  and choose *Arrow Volume*.

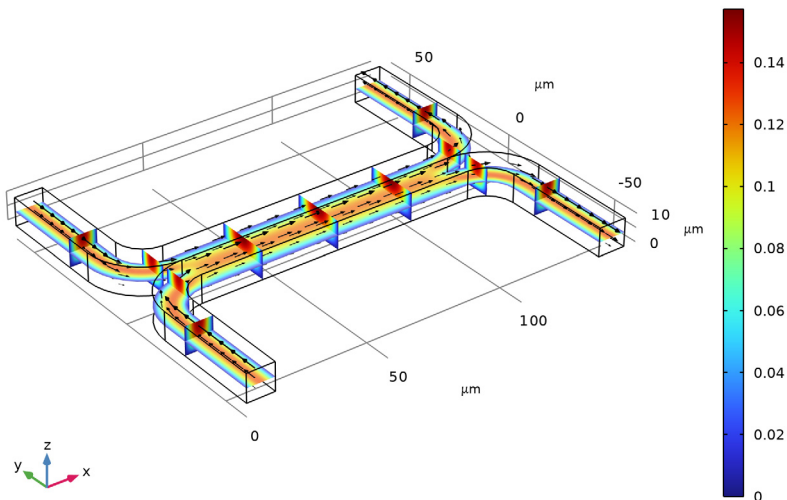

- 2 In the Settings window for Arrow Volume, locate the Arrow Positioning section.
  - Find the x grid points subsection. In the Points text field, type 14.
  - Find the y grid points subsection. In the Points text field, type 21.
  - Find the z grid points subsection. In the Points text field, type 3.
- 3 Locate the Coloring and Style section. From the Color list, choose Black.
- 4 In the Velocity (Uncoupled Flow) toolbar, click Plot .

D(3)=1E-11 m<sup>2</sup>/s    Slice: Velocity magnitude (mm/s)    Arrow Volume: Velocity field



Next add a pressure plot, using the dataset created previously.

### Pressure (Uncoupled Flow)

- 1 In the Home toolbar, click Add Plot Group  and choose 3D Plot Group .
- 2 In the Settings window for 3D Plot Group, type Pressure (Uncoupled Flow) in the Label text field.
- 3 Locate the Data section. From the Dataset list, choose Surface 1.

### Surface 1





Add a uniformly colored surface to highlight the channel walls.

- 1 Right-click Pressure (Uncoupled Flow)  and choose Surface .

- 2 In the Settings window for Surface, locate the Expression section. In the Expression text field, type 1.
- 3 Locate the Coloring and Style section.
  - From the Coloring list, choose Uniform.
  - From the Color list, choose Gray.

### Contour 1

Next use contours to visualize the pressure.

- 1 Right-click Pressure (Uncoupled Flow)  and choose Contour .
- 2 In the Settings window for Contour, click Replace Expression  in the upper-right corner of the Expression section. From the menu, choose Component 1 (comp1) > Creeping Flow > Velocity and pressure > p – Pressure – Pa.
- 3 In the Pressure (Uncoupled Flow) toolbar, click Plot .

D(3)=1E-11 m<sup>2</sup>/s

Surface: 1 (1) Contour: Pressure (Pa)

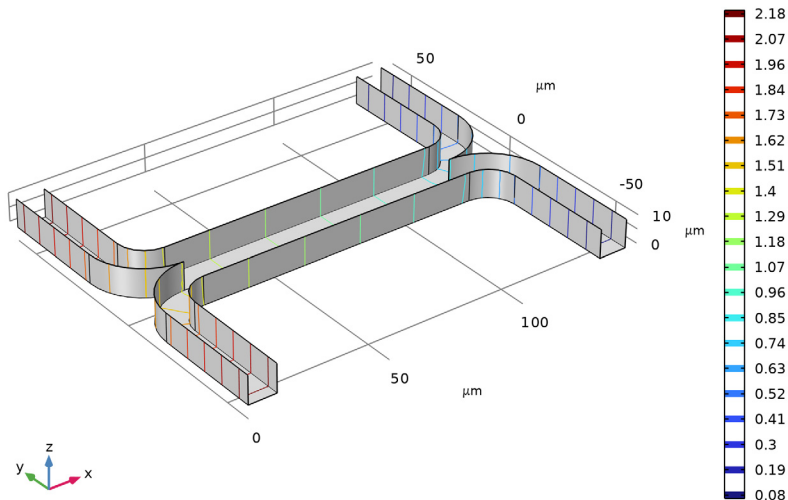

Next create a slice plot to visualize the concentration in the device. Use the existing velocity slice plot as a basis for this plot.



### Concentration (Uncoupled Flow)

- 1 In the Model Builder window, under Results right-click Velocity (Uncoupled Flow)  and choose Duplicate .



2 In the Label text field, type Concentration (Uncoupled Flow).

For each of the slice subnodes, change the plotted quantity to concentration.



### Slice 1

- 1 In the Model Builder window, expand the Results > Concentration (Uncoupled Flow) node, then click Slice 1 .
- 2 In the Settings window for Slice, click Replace Expression  in the upper-right corner of the Expression section. From the menu, choose Component 1 (comp1) > Transport of Diluted Species > Species c > c – Molar concentration, c – mol/m<sup>3</sup>.

### Slice 2



- 1 In the Model Builder window, click Slice 2 .
- 2 In the Settings window for Slice, click Replace Expression  in the upper-right corner of the Expression section. From the menu, choose c – Molar concentration, c – mol/m<sup>3</sup>.

### Slice 3

- 1 Repeat steps 1 and 2 in Slice 2 for Slice 3 .  
Disable the arrow volume plot.
- 2 Right-click Arrow Volume 1  and choose Disable .

### Concentration (Uncoupled Flow)

Look at the plot for each of the three diffusion coefficient levels.

- 1 Click Concentration (uncoupled flow) .
- 2 In the Settings window for 3D Plot Group locate the Data section. From the Parameter value (D) list, choose each of the values: 1e-11, 5e-11, and 1e-10, clicking the Plot button  after each selection.

The plots on the next page show the results for each of the diffusion coefficients solved for. For the heaviest species, which has the smallest diffusivity, there is

limited mixing between streams A and B. For the lightest species, which has the largest diffusion coefficient, the mixing is almost perfect.

$D(3)=1E-11 \text{ m}^2/\text{s}$

Molar concentration,  $c \text{ (mol/m}^3\text{)}$

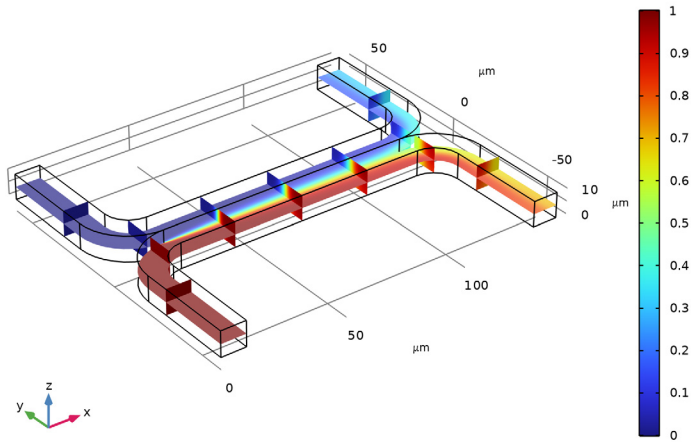

$D(2)=5E-11 \text{ m}^2/\text{s}$

Molar concentration,  $c \text{ (mol/m}^3\text{)}$

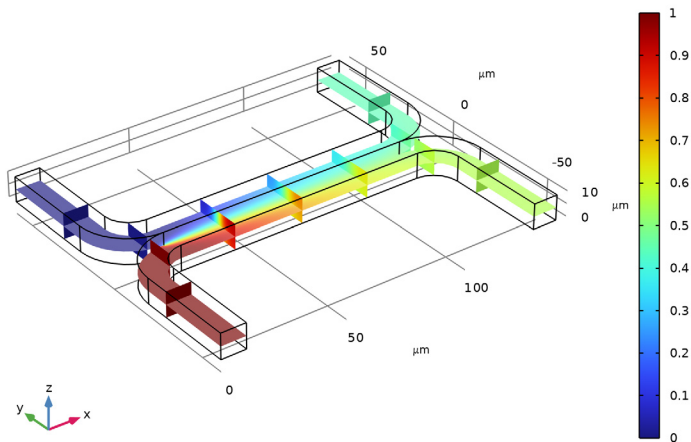



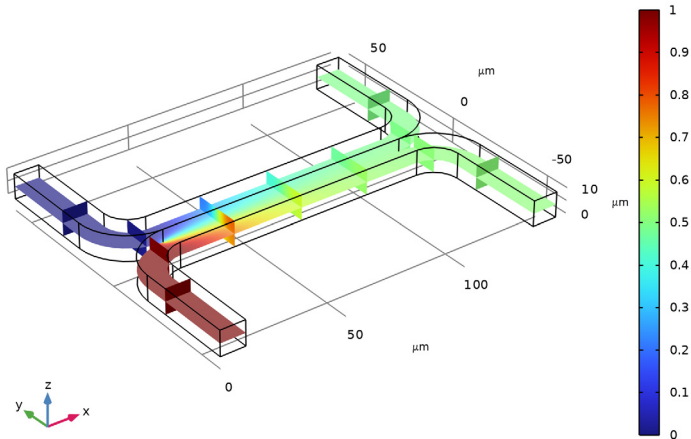

$D(1)=1E-10 \text{ m}^2/\text{s}$

Molar concentration,  $c \text{ (mol/m}^3\text{)}$



Add a global plot to show how the concentration at the output differs with diffusion coefficient.

### *Output Concentration (Uncoupled Flow)*

- 1 In the Home toolbar, click Add Plot Group  and choose 1D Plot Group .
- 2 In the Settings window for 1D Plot Group, type Output Concentration (Uncoupled Flow) in the Label text field.
- 3 Right-click Output Concentration (Uncoupled Flow) and choose Global .  
Use the built in variable to compute the average concentration at the device output.
- 4 In the Settings window for Global, click Replace Expression  in the upper-right corner of the y-Axis Data section. From the menu, choose Component 1 > Transport of Diluted Species > Outflow 2 > tds.out2.c0\_avg\_c - Average concentration - mol/m<sup>3</sup>.
- 5 Locate the x-Axis Data section. From the Parameter list, choose Expression. In the Expression text field, type D.
- 6 Click to expand the Legends section. Clear the Show legends checkbox (no legend is necessary for this plot, as only one quantity is plotted).  
Add a marker in the computed data points.

7 Click to expand the Coloring and Style section. Find the Line markers subsection.

- From the Marker list, choose Point.

Change the axis titles.

**Note:** HTML tags and a range of mathematical symbols and Greek letters can be entered in the axes and plot titles. See “Using Special Formats and Symbols in Texts” in the “Results Evaluation and Visualization” chapter of the *COMSOL Multiphysics Reference Manual* for more information.

8 In the Model Builder window, click Output Concentration (Uncoupled Flow) .

9 In the Settings window for 1D Plot Group, click to expand the Title section. From the Title type list, choose None.

10 In the Settings window for 1D Plot Group, locate the Plot Settings section.

- Select the x-axis label checkbox. In the associated text field, enter Diffusion Coefficient ( $\text{m}^2/\text{s}$ ).
- Select the y-axis label checkbox. In the associated text field, enter Concentration at Stream B Outlet ( $\text{mol}/\text{m}^3$ ).

Change the axis limits for the plot.

11 Locate the Axis section. Select the Manual axis limits checkbox.

- In the y minimum text field, enter 0.
- In the y maximum text field, enter 0.5.

## 12 Click Plot .

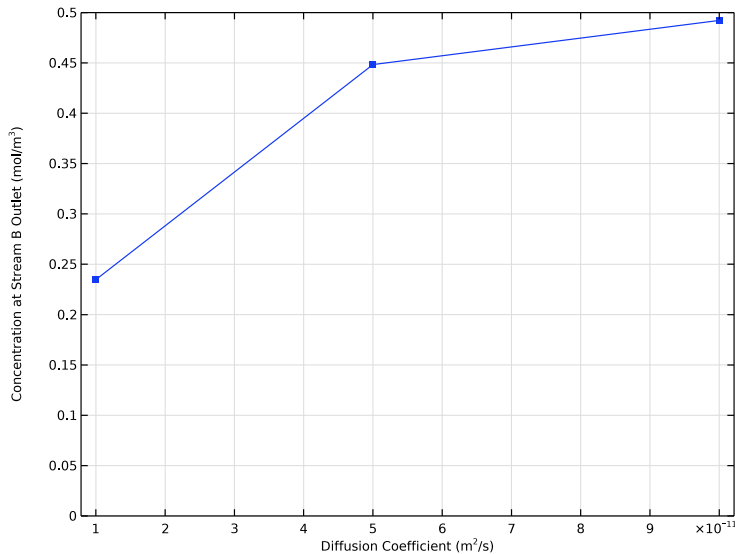

This plot shows that the concentration of the species at the output is strongly dependent on the diffusion coefficient of the molecule. Thus the device could be used to separate species with different diffusion coefficients, particularly if multiple stages of the device were arranged in series.

In some cases, particularly if the solution consists of large macromolecules, the dissolved species has a large influence on the liquid's viscosity. In such situations, the Navier–Stokes and the convection–diffusion equations become coupled, and so they must be solved simultaneously.

## Creeping Flow

---

Now set up the fully coupled problem. Add a new Fluid Properties node that will be used to set up the fully coupled problem. To make the viscosity a function of the species concentration simply enter an expression into the dynamic viscosity setting of the fluid properties node.

### *Fluid Properties: Uncoupled*

1 In the Model Builder window, under Creeping Flow click Fluid Properties 1



- 2 In the Settings window for Fluid Properties, type Fluid Properties: Uncoupled in the Label text field.

### *Fluid Properties: Coupled*

- 1 Right click Fluid Properties: Uncoupled and choose Duplicate .
- 2 In the Settings window for Fluid Properties, type Fluid Properties: Coupled in the Label text field.
- 3 In the Settings window for Fluid Properties, locate the Fluid Properties section.
- 4 From the  $\mu$  list, choose User defined. In the associated text field, type  $1e-3[\text{Pa}\cdot\text{s}]*(1+\alpha\text{1pha}\cdot\text{c}^2)$ .

Deactivate the Fluid Properties: Coupled node in Study 1 to be able to reproduce the uncoupled results in the future. Then, add a new study to solve the fully coupled problem.





### *Step 1: Stationary*

- 1 In the Model Builder window, under Study 1 click Step 1: Stationary.
- 2 In the Settings window for Stationary, locate the Physics and Variables Selection section.
- 3 Select the Modify model configuration for study step checkbox. Click to change the check mark  to .
- 4 In the tree, select Component 1 (comp 1) >Creeping Flow (spf) > Fluid Properties: Coupled. Right click and choose Disable .

## **Study 2**

---

Add a study to solve the fully coupled problem. In this instance only a single diffusion coefficient will be solved for, so no parametric sweep will be required. The model will default to the parameter entered on the parameters node for the diffusion constant:  $5\times 10^{-11} \text{ m}^2/\text{s}$ .

- 1 In the Home toolbar, click Add Study  to open the Add Study window.
- 2 In the Add Study window, find the Studies subsection. In the Select Study tree, under General Studies click Stationary .
- 3 In the Add study window click Add Study .
- 4 In the Home toolbar, click Add Study  again to close the Add Study window. Next, turn off the default plot groups again.
- 5 In the Model Builder window, click Study 2 .



- 6 In the Settings window for Study, locate the Study Settings section. Clear the Generate default plots checkbox.
- 7 In the Home toolbar, click Compute  .

## Results

---



Add another surface dataset that points to the new solution.

### *Datasets*

- 1 In the Model Builder window, under Results > Datasets right-click Surface 1  and choose Duplicate .
- 2 In the Settings window for Surface, locate the Data section. From the Dataset list, choose Study 2/Solution 3 (sol3).

### *Velocity (Coupled Flow)*

Recreate the velocity, pressure, and concentration plots for the fully coupled problem.

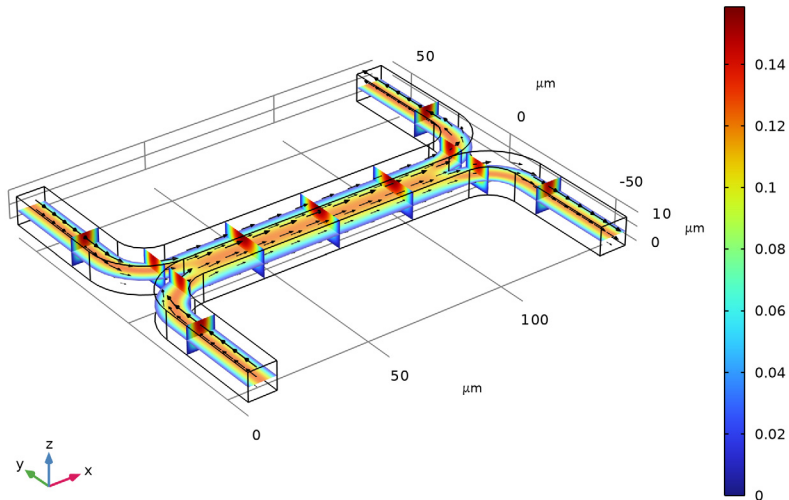

- 1 In the Model Builder under Results, right-click Velocity (Uncoupled Flow)  and choose Duplicate .
- 2 In the Settings window for 3D Plot Group, type Velocity (Coupled Flow) in the Label text field.
- 3 Locate the Data section. From the Dataset list, choose Study 2/Solution 3 (sol3).
- 4 In the Velocity (Coupled Flow) toolbar, click Plot .

Slice: Velocity magnitude (mm/s) Arrow Volume: Velocity field



There are significant differences in the flow pattern, although these are hard to see when comparing this plot with the similar one generated previously. The flow through a slice of the channel will be investigated in more detail later to better highlight these differences.

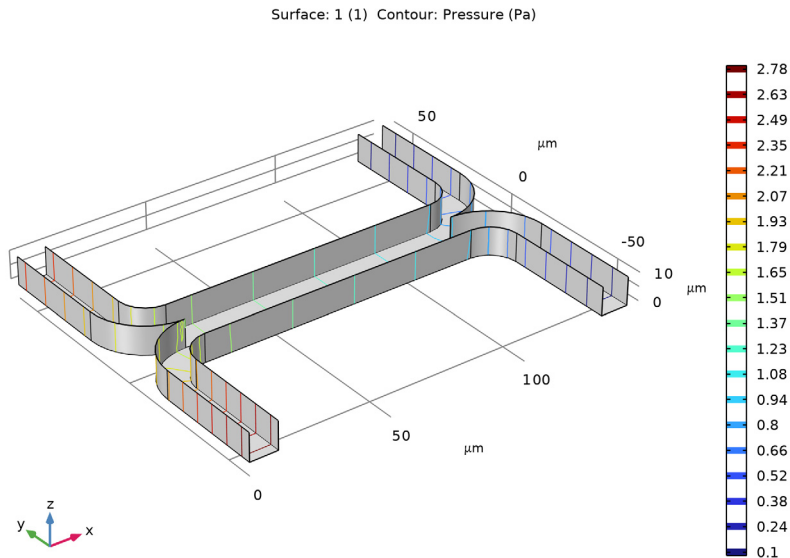

### *Pressure (Coupled Flow)*

- 1 In the Model Builder window, under Results right-click Pressure (Uncoupled Flow)  and choose Duplicate .
- 2 In the Settings window for 3D Plot Group, type Pressure (Coupled Flow) in the Label text field.
- 3 Locate the Data section. From the Dataset list, choose Surface 2.
- 4 In the 3D plot group toolbar, click Plot .



The pressure distribution in the channel has changed significantly as a result of the increased viscosity of the fluid that contains the added species. Thus the two inlets must be maintained at different pressures. This may be possible for a single stage, but it would significantly complicate the design of a multiple stage device.

### Concentration (Coupled Flow)

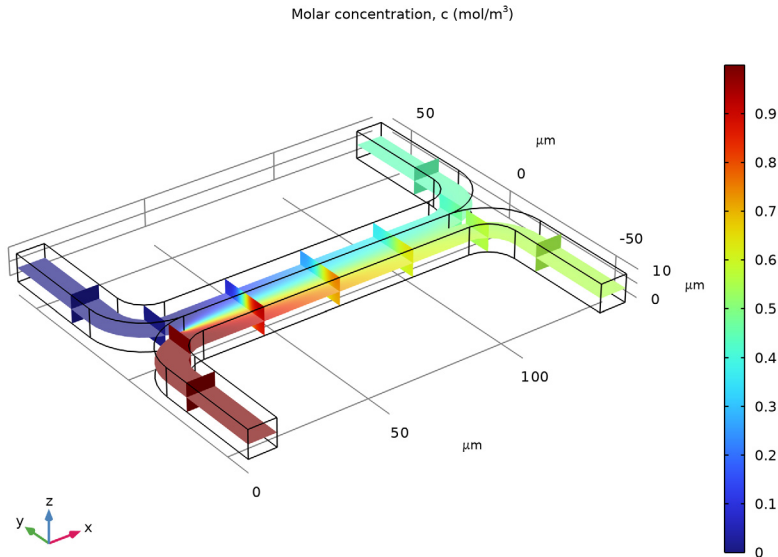

- 1 In the Model Builder window, under Results right-click Concentration (Uncoupled Flow)  and choose Duplicate .
- 2 In the Settings window for 3D Plot Group, type Concentration (Coupled Flow) in the Label text field.
- 3 Locate the Data section. From the Dataset list, choose Study 2/Solution 3 (sol 3).
- 4 In the Concentration (Coupled Flow) toolbar, click Plot .



The concentration distribution is affected only slightly by the coupling between the flow and the concentration.

Next add a cut plane dataset in the center of the channel, for both the uncoupled and fully coupled solutions. These will be used to visualize the change in the flow profile induced by the coupling.

### Datasets

- 1 In the Results toolbar, click Cut Plane .
- 2 In the Settings window for Cut Plane, locate the Plane Data section. In the x-coordinates text field, type 70.
- 3 Under Datasets, right-click Cut Plane 1  and choose Duplicate .
- 4 In the Settings window for Cut Plane, locate the Data section. From the Dataset list, choose Study 2/Solution 3 (sol 3).



### Velocity Comparison

Add a 2D contour plot of the velocity magnitude.

- 1 In the Results toolbar, click 2D Plot Group .
- 2 In the Settings window for 2D Plot Group, type Velocity Comparison in the Label text field.



**3** Locate the Data section.

- From the Dataset list, choose Cut Plane 1.
- From the Parameter value (D (m<sup>2</sup>/s)) list, choose 5e-11.

**4** Right-click Velocity Comparison  and choose Contour .

**5** In the Settings window for Contour, locate the Levels section. In the Total levels text field, type 5.

Create a duplicate contour plot, using the same colors and scales, but showing the coupled data.

**6** Under Velocity Comparison , right click Contour 1  and choose Duplicate .

**7** In the Settings window for Contour, locate the Data section. From the Dataset list, choose Cut Plane 2.

**8** Click to expand the Title section. From the Title type list, choose None.

**9** Locate the Coloring and Style section. Clear the Color legend checkbox.

**10** Click to expand the Inherit Style section. From the Plot list, choose Contour 1.

**11** In the Velocity Comparison toolbar, click Plot .

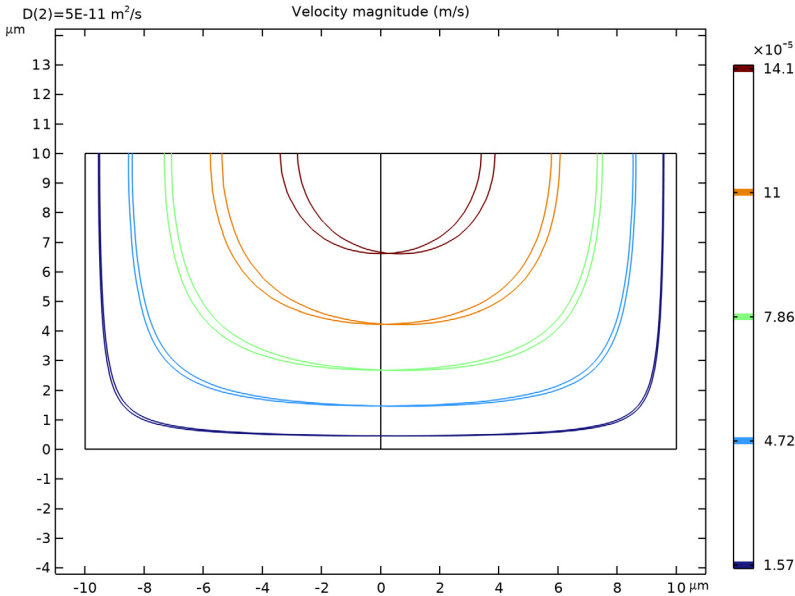

**12** Click the Zoom Extents button  in the Graphics toolbar





Now it is possible to compare the velocity distributions more carefully. It is clear that the coupling has introduced an asymmetry into the flow pattern as a result of the higher viscosity in the fluid containing the dissolved species.

Finally compare the output concentration between the two solutions.

### *Global Evaluation 1*

- 1 In the Results toolbar, click  Global Evaluation.
- 2 In the Settings window for Global Evaluation, click Replace Expression  in the upper-right corner of the Expressions section. From the menu, choose Component 1 (comp 1) > Transport of Diluted Species > Outflow 2 > tds.out2.c0\_avg\_c - Average concentration - mol/m<sup>3</sup>.
- 3 Click the Evaluate button  .  
When the diffusion coefficient is  $5 \times 10^{-11} \text{ m}^2/\text{s}$  the mean concentration at the outlet is  $0.448 \text{ mol/m}^2$ .

### *Global Evaluation 2*

- 1 Under Derived Values, right-click Global Evaluation 1  and choose Duplicate .
- 2 In the Settings window for Global Evaluation, locate the Data section. From the Dataset list, choose Study 2/Solution 3 (sol3).
- 3 Right-click Global Evaluation 2  and choose Evaluate > New Table.

Only a small difference occurs in the output concentration as a result of the coupling between the problems. However, the coupling would make adding multiple stages of the device together much more difficult, as different pressures are required at the two inlets to obtain the same flow velocity in the two streams.

