



INTRODUCTION TO Heat Transfer Module

Introduction to the Heat Transfer Module

© 1998–2025 COMSOL

Protected by patents listed on www.comsol.com/patents, or see Help > About COMSOL Multiphysics on the File menu in the COMSOL Desktop for less detailed lists of U.S. Patents that may apply. Patents pending.

This Documentation and the Programs described herein are furnished under the COMSOL Software License Agreement (www.comsol.com/sla) and may be used or copied only under the terms of the license agreement.

COMSOL, the COMSOL logo, COMSOL Multiphysics, COMSOL Desktop, COMSOL Compiler, COMSOL Server, and LiveLink are either registered trademarks or trademarks of COMSOL AB. All other trademarks are the property of their respective owners, and COMSOL AB and its subsidiaries and products are not affiliated with, endorsed by, sponsored by, or supported by those trademark owners. For a list of such trademark owners, see www.comsol.com/trademarks.

Version: COMSOL 6.4

Contact Information

Visit the Contact COMSOL page at www.comsol.com/contact to submit general inquiries or search for an address and phone number. You can also visit the Worldwide Sales Offices page at www.comsol.com/contact/offices for address and contact information.

If you need to contact Support, an online request form is located on the COMSOL Access page at www.comsol.com/support/case. Useful links:

- Support Center: www.comsol.com/support
- Product Download: www.comsol.com/product-download
- Product Updates: www.comsol.com/product-update
- COMSOL Blog: www.comsol.com/blogs
- Discussion Forum: www.comsol.com/forum
- Events: www.comsol.com/events
- COMSOL Video Gallery: www.comsol.com/videos
- Support Knowledge Base: www.comsol.com/support/knowledgebase
- Learning Center: www.comsol.com/support/learning-center

Part number: CM020804

Contents

Introduction	5
Basic Concepts Described in the Heat Transfer Module.	6
The Applications	8
The Heat Transfer Module Physics Interfaces	15
Physics Interface Guide by Space Dimension and Study Type	22
Tutorial Model — Electronic Chip Cooling	34
Model Definition.	34
Results with Convective Cooling Boundary Condition	35
Results with Nonisothermal Flow in the Channel.	38
Laminar Flow	60

Introduction

The Heat Transfer Module is used by product designers, developers, and scientists who use detailed geometric models to study the influence of heating and cooling in devices and processes. It contains modeling tools for the simulation of all mechanisms of heat transfer including conduction, convection, and radiation. Simulations can be run for transient and steady conditions in 1D, 1D axisymmetric, 2D, 2D axisymmetric, and 3D coordinate systems.

The high level of detail provided by these simulations allows for the optimization of design and operational conditions in devices and processes influenced by heat transfer.

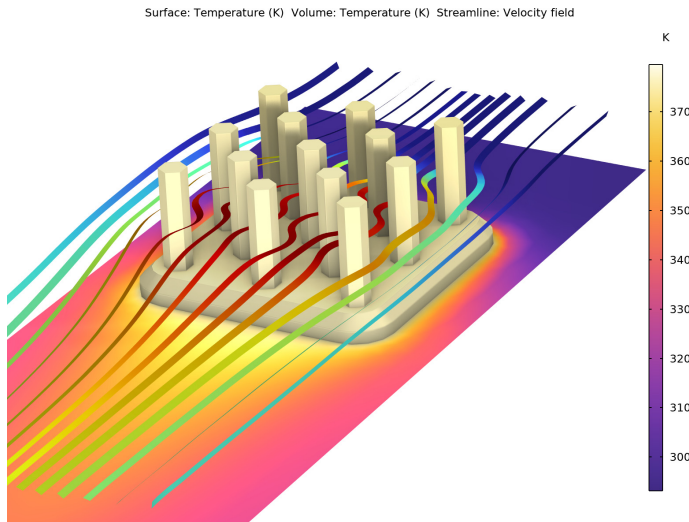

Figure 1: The temperature and flow field in an aluminum heat sink and in cooling air that is pumped over the heat sink. The temperature and flow field are solved using detailed geometry and a description of the physics.

The Application Libraries window contains tutorials as well as industrial equipment and device benchmark applications for verification and validation.

This introduction fine-tunes your COMSOL Multiphysics® modeling skills for heat transfer simulations. The model tutorial solves a conjugate heat transfer problem from the field of electronic cooling, but the principles are applicable to any field involving heat transfer in solids and fluids.

Basic Concepts Described in the Heat Transfer Module

Heat is one form of energy that, like work, is in transit inside a system or from one system to another. This energy may be stored as kinetic or potential energy in the atoms and molecules of a system.

Conduction is a form of heat transfer that can be described as proportional to the temperature gradients in a system. This is formulated mathematically by Fourier's law. The Heat Transfer Module describes conduction in systems where thermal conductivity is constant or is a function of temperature or any other model variable, for example, chemical composition.

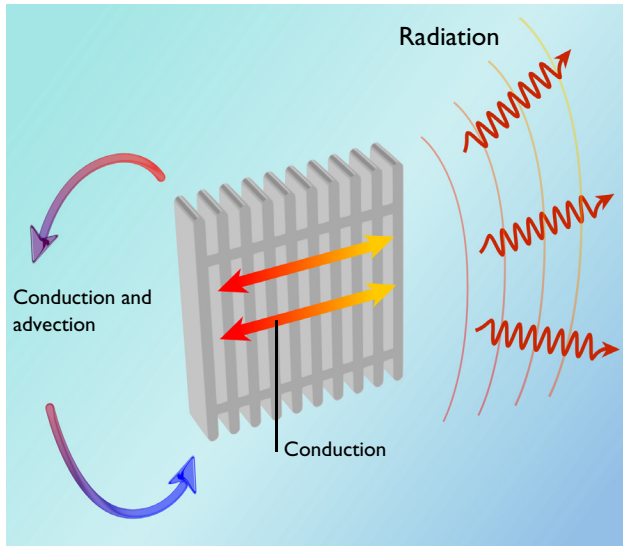

Figure 2: Heat transfer in a system containing a solid surrounded by a fluid (conjugate heat transfer). In the fluid, heat transfer can take place through conduction and advection, while in a solid, conduction is the main heat transfer mechanism. Heat transfer by radiation can occur between surfaces or between surfaces and their surroundings.

In the case of a moving fluid, the energy transported by the fluid has to be modeled in combination with fluid flow. This is referred to as *convection of heat* and must be accounted for in forced and free convection (conduction and advection). This module includes descriptions for heat transfer in fluids and conjugate heat transfer (heat transfer in solids and fluids in the same system), for both laminar and turbulent flows. In the case of turbulent flow, the module offers two algebraic turbulence models, the *Algebraic γ Plus* and *L-VEL* models, as well as the standard k - ϵ model for high-Reynolds numbers, the low Reynolds number k - ϵ model, and the SST (shear stress transport) model to accurately describe conjugate heat transfer. The Gravity feature defines buoyancy forces induced by density differences, in particular due to temperature dependency of the density.

Radiation is the third mechanism for heat transfer that is included in the module. The associated features handle surface-to-ambient radiation, surface-to-surface radiation, and external radiation sources (for example, the sun). The surface-to-surface radiation capabilities support mixed diffuse-specular reflection as well as transmission through semitransparent layers. Surface properties may be a function of several parameters, in particular of the position, the temperature, the wavelength or the incident angle. The Heat Transfer Module also contains functionality for radiation in participating and absorbing media. This radiation model accounts for the absorption, emission, and scattering of radiation by the material present between radiating surfaces. The module offers three models for participating and absorbing media simulations: the discrete ordinates method (DOM), the P1 method, and the Rosseland approximation. Finally the Radiative Beam in Absorbing Media interface provides features to define the absorbing media properties, as well as options for multiple incident beams.

The basis of the Heat Transfer Module is the study of the balance of energy in a system. The contributions to this energy balance originate from conduction, convection, and radiation, as well as from latent heat, Joule heating, heat sources, and heat sinks. In the case of moving solids, translational terms may also be included in the heat transfer models, such as for solids in rotating machinery. The effects of solid deformations on thermal properties can also be modeled. Physical properties and heat sources (or sinks) can be described as arbitrary expressions containing the dependent variables in a model (for example, temperature and electric field). The heat transfer equations are defined automatically by the dedicated physics interfaces for heat transfer and fluid flow. The formulations of these equations can be visualized in detail for validation and verification purposes.

Physical properties such as thermal conductivity, heat capacity, density, and emissivity can be obtained from the built-in material library for solids and fluids and from the Material Library add-on in COMSOL Multiphysics. In addition, the Heat Transfer Module contains relations for the calculation of heat transfer coefficients for different types of convective heat transfer from a surface. For turbulent heat transfer, it also features relations used to calculate the thermal conductivity in turbulent flow, using the eddy diffusivity from turbulence models (sometimes referred to as turbulent conductivity).

The modeling workflow is straightforward and is defined by the following steps: define the geometry, select the material to be modeled, select the type of heat transfer, define the boundary and initial conditions, define the finite element mesh, select a solver, and visualize the results. All of these steps are accessed from the COMSOL Desktop. The mesh and solver steps are often automatically included with the default settings, which are tailored to each type of heat transfer interface.

The Applications

Heat generation and transfer are present in most physical processes and phenomena, either as side effects or as desired effects. The Heat Transfer Module can be effectively used to study a variety of processes (for example, building ventilation effects), to account for turbulent free convection and heat transfer; to analyze the impact of heat generation and cooling in electronic microdevices; and to study phase change effects.

The Application Library in the Heat Transfer Module contains tutorial and benchmark models from different engineering applications.

The Applications section in the Application Library contains ready-made applications that can be run using a dedicated interface. These applications are designed to solve a particular class of problems in a simplified user interface that makes it easy to use, even for non-COMSOL Multiphysics users.

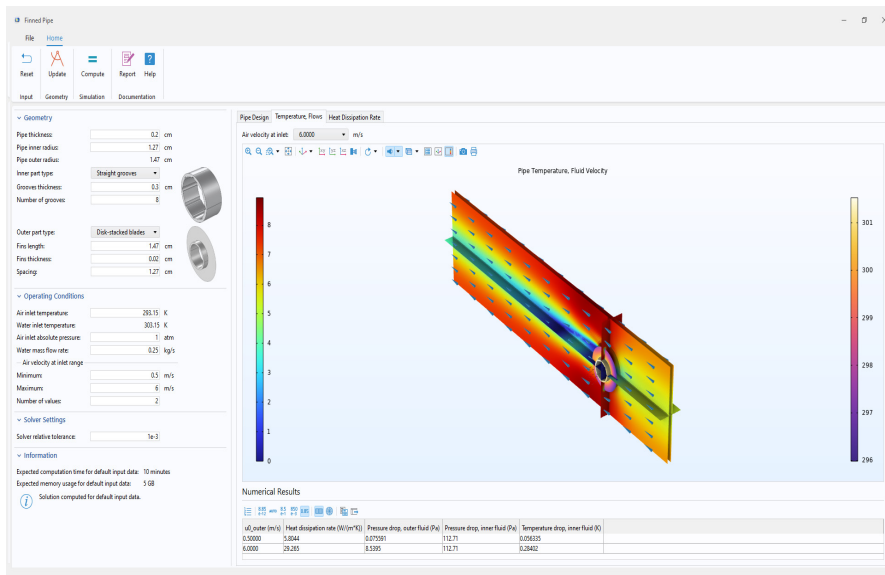

Figure 3: Snapshot of an application dedicated to finned pipe characterization. The application computes finned pipe properties such as the pressure drop and the temperature drop in the pipe. The finned pipe design and the operating conditions are customizable via a dedicated user interface.

The *Building and Constructions* section in the Application Library includes files that are related to energy efficiency and dissipation in buildings. Most of these use convective heat flux to account for heat exchange between a structure and its surroundings. Simulation provides accurate depictions of the heat and energy fluxes that inform energy management in buildings and construction.

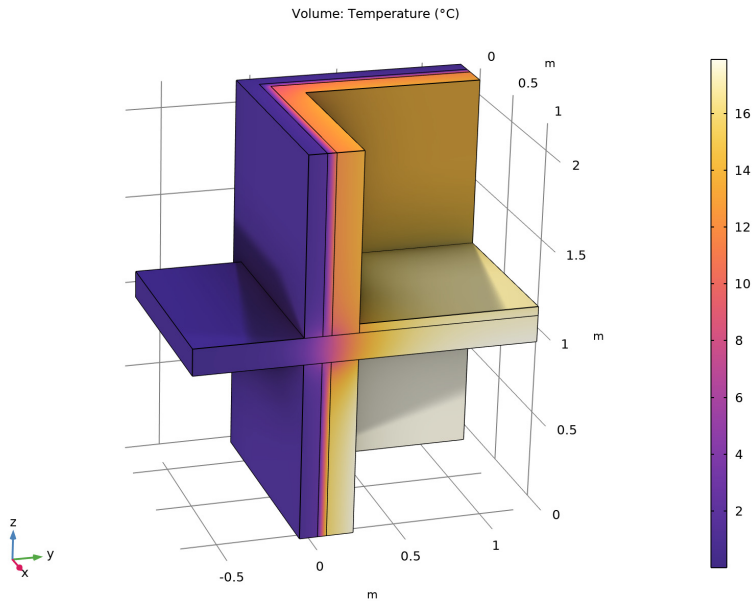

Figure 4: Temperature field in a building wall exposed to a cold environment. This plot is from the model *Thermal Bridge 3D — Two Floors*.

The *Heat Exchangers* section in the Application Library presents several heat exchangers of different sizes, flow arrangements, and flow regimes. They benefit from the predefined Conjugate Heat Transfer interface that provides ready-to-use features for couplings between solids, shells, and laminar or turbulent flows. The simulation results show properties of the heat exchangers, such as their efficiency, pressure loss, or compactness.

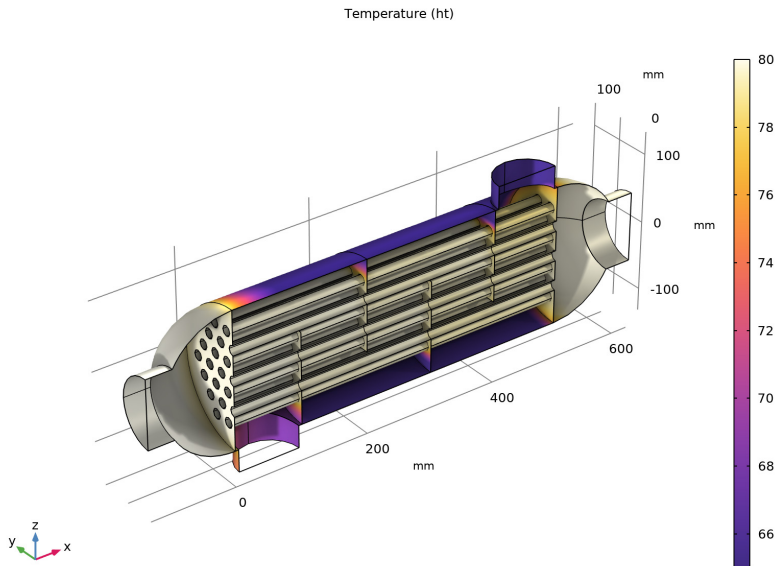

Figure 5: Wall temperature in a shell-and-tube heat exchanger resulting from heat exchange between a cold and a hot fluids separated by a thin wall. This plot is from the Shell-and-Tube Heat Exchanger model.

The *Medical Technology* section in the Application Library introduces the concept of bioheating. Here, the influences of various processes in living tissue are accounted for as contributions to heat flux and as sources and sinks in the heat balance relations. Bioheating applications that can be modeled include the microwave heating of tumors (such as hyperthermia cancer therapy) and the interaction between microwave antennas and living tissue (such as the influence of a diagnostic probe or cellphone use on the temperature of tissue close to the ear). The benefit of using the bioheat equation is that it has been validated for different types of living tissue, using empirical data for the different properties, sources, and sinks. In addition, damage-integral features are provided to model tissue necrosis due to hyperthermia or hypothermia. The models and simulations available in this physics interface provide excellent complements to experimental and clinical trials; the results may be used for many purposes, for example, to develop new methods for dose planning.

The *Orbital Thermal Loads* section in the Application Library presents applications related to spacecraft thermal analysis. All the applications include the definition of the planet, orbit, and spacecraft properties. From this information the position and orientation of the spacecraft, but also the direct solar radiation,

albedo, and planet radiative flux as well as the radiative heat transfer between the different spacecraft parts are computed. It is possible to analyze further the heat transfer in the spacecraft by including a heat transfer physics interface in the model to account for the energy balance including the heat conduction in solid parts.



Figure 6: Orbit of a satellite around the Earth. The track color indicates whether the satellite is in eclipse or not. The spacecraft surface color represents the magnitude of the incident solar irradiation.

The *Phase Change* section in the Application Library presents applications such as metal melting, evaporation, and food cooking. A common characteristic of these models is that the temperature field defines the material phase, which has a significant impact on the material properties. Equations representing the highly nonlinear behavior of the material properties as a function of temperature are automatically generated by the Phase Change Material subfeature or the Phase Change Interface boundary condition. The phase change model provides information to control material transformation.

The *Power Electronics and Electronic Cooling* section in the Application Library includes examples that often involve heat generation, heat transfer in solids, and conjugate heat transfer (where cooling is described in greater detail). The examples in these applications are often used to design cooling systems and to control the operating conditions of electronic devices and power systems. The

module provides the tools needed to understand and optimize flow and heat transfer mechanisms in these systems when the model results are interpreted.

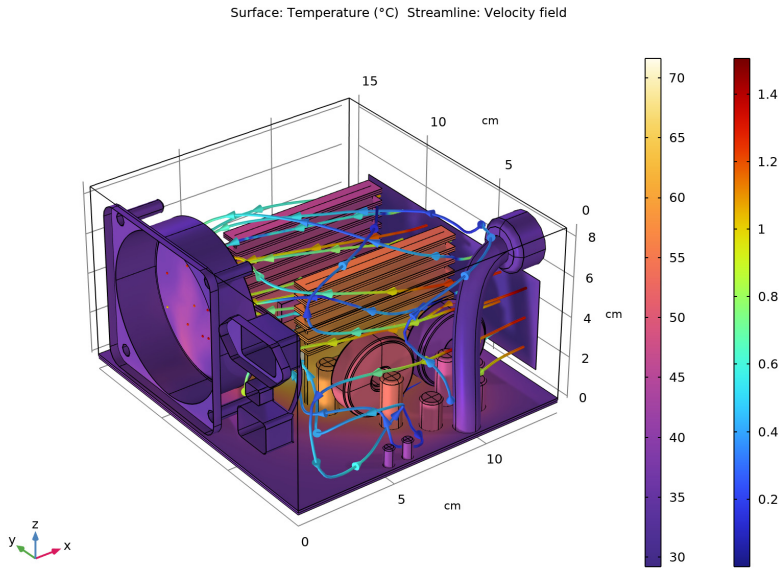

Figure 7: Temperature field and flow streamlines as a result of conjugate heat transfer in computer power supply unit (PSU). This plot is from the *Electronic Enclosure Cooling* tutorial model.

The *Thermal Contact and Friction* section in the Application Library contains examples where thermal cooling is dependent on a thermal contact or where the heat source is due to friction. The thermal contact properties can be coupled with structural mechanics that provide the contact pressure at the interface. It is also possible to combine thermal contact and electrical contact in the same model.

The *Thermal Processing* section in the Application Library contains examples that include thermal processes, such as continuous casting. A common characteristic of most of these examples is that the temperature field and the temperature variations have a significant impact on the material properties or the physical behavior (thermal expansion, thermophoresis, and so forth) of the modeled process or

device. Since these couplings make the processes very complicated, modeling and simulation often provide a useful shortcut to a complex understanding.

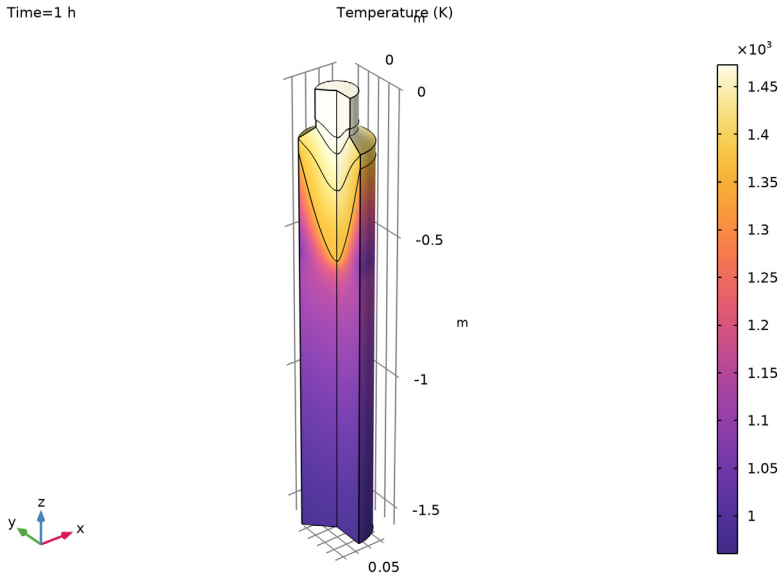

Figure 8: Temperature field plot from the Continuous Casting — Arbitrary Lagrangian-Eulerian Method model. A sharp temperature gradient is found across the mushy layer, where the liquid metal solidifies.

The *Thermal Radiation* section in the Application Library contains applications where heat transfer by radiation must be considered in order to describe the heat flux accurately. A common feature of these examples is that they contain devices where high radiative heat transfer is observed due to high temperature, high surface emissivity, or external radiation like solar radiation. These applications account for the nonlinearity that results from the radiative heat transfer and geometric effects such as shielding between two radiating objects. The geometry or the radiation source may be moving or deformed during the simulation.

The *Thermal Stress* section in the Application Library presents examples where the temperature field causes thermal expansion. Thermal stress can result from heat exchanges between cold and hot devices or from processes like Joule heating. These require the Structural Mechanics Module or the MEMS Module for the portions where structural mechanics are simulated.

The *Tutorials* section in the Application Library contains examples that demonstrate the implementation of a particular phenomenon or the use of some features. Reproducing these applications is an effective method to discover the capabilities of the Heat Transfer Module and to get more experience using it.

The *Verification Examples* section in the Application Library provides examples that reproduce a case with a known solution and compare it with COMSOL Multiphysics results.

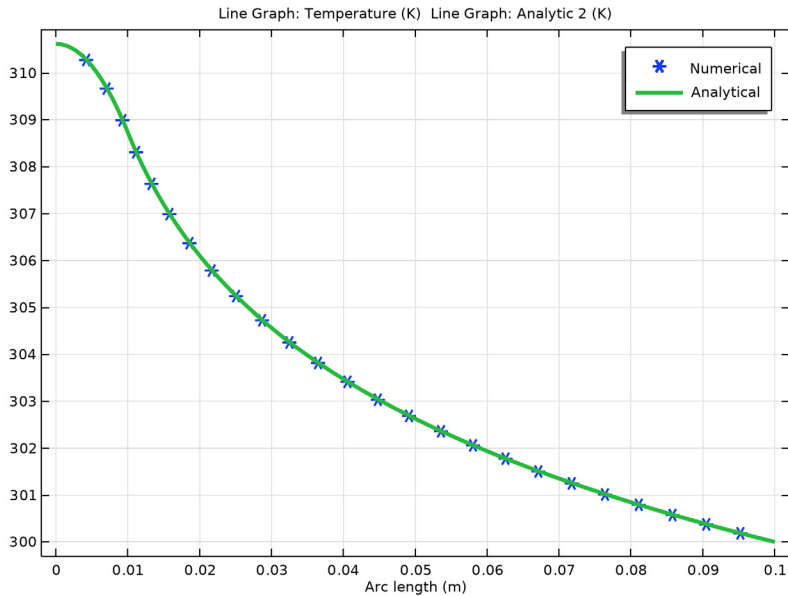







Figure 9: Comparison of the temperature obtained by COMSOL Multiphysics and an analytical solution (green line).

The next section describes the available physics interfaces in this module.

HEAT TRANSFER



By default, the Heat Transfer in Solids interface () describes heat transfer by conduction. It can also account for heat flux due to translation in solids (for example, the rotation of a disk or the linear translation of a shaft) as well as for solid deformation, including volume or surface changes. In the case of irreversible thermally induced transformation, it accounts for the enthalpy and material properties changes.

The Heat Transfer in Fluids interface () accounts for conduction and convection in gases and liquids as the default heat transfer mechanisms. The coupling to the flow field in the convection term is automatically set when the Nonisothermal Flow multiphysics coupling is used. Otherwise, it may be entered manually in the physics interface, or it may be selected from a list that couples heat transfer to an existing fluid flow interface. The Heat Transfer in Fluids interface can be used when the flow field has already been calculated and the heat transfer problem is added afterward, typically for simulations of forced convection.

The Heat Transfer in Solids and Fluids interface () contains solids and fluids domains by default. It is aimed to simplify the setup of models where capabilities of Heat Transfer in Solids interface () and Heat Transfer in Fluids interface () are used, in particular in conjugate heat transfer applications.

The Lumped Thermal System interface () extends the heat transfer modeling possibility to the discrete thermal systems. The external terminal feature connects a lumped thermal system to a finite element model in any dimension. This is particularly helpful to reduce dramatically the models complexity, for example to describe thermal interaction between parts in large assemblies. Several classical devices like conductive or radiative thermal resistor are predefined. In addition advanced devices, heat pipe and thermoelectric module, and user's defined subsystems are available.





The Bioheat Transfer interface () is a dedicated interface for heat transfer in living tissue. In addition to data such as thermal conductivity, heat capacity, and density, tabulated data is available for blood perfusion rates and metabolic heat sources. Tissue damage integral models based on a temperature threshold or an energy absorption model can also be included.

With the Pipe Flow Module the Heat Transfer in Pipes interface () is available. It computes the energy balance in pipe systems but receives the flow field as a value or as a known solved field. Wall heat transfer to the surroundings is included. The Pipe Flow Module also provides the Nonisothermal Pipe Flow interface () solves the flow, pressure, and temperature simultaneously and fully coupled.

The Thermoelectric Effect interface () combines the Electric Currents and the Heat Transfer in Solids interfaces with capabilities for modeling thermoelectric effects (Peltier-Seebeck-Thomson effects) as well as Joule heating (resistive

heating). This multiphysics coupling accounts for Peltier heat source or sink and resistive losses in the Heat Transfer interfaces as well as for the current induced by the Seebeck effect and for the temperature dependency of material properties in the Electric Currents interface. This physics interface is automatically paired with the AC/DC module capabilities for advanced modeling of electric effects.

CONJUGATE HEAT TRANSFER

The Conjugate Heat Transfer interfaces () combine all features from the Heat Transfer and Single-Phase Flow interfaces to describe heat transfer in solids and fluids and nonisothermal flow in fluids. The heat transfer process is tightly coupled with the fluid flow problem via a predefined multiphysics coupling. These interfaces are available for laminar and turbulent nonisothermal flow and flow in porous media (Brinkman equation). For highly accurate simulations of heat transfer between a solid and a fluid in the turbulent flow regime, low-Reynolds turbulence models resolve the temperature field in the fluid all the way to the solid wall. This model is available in the Turbulent Flow, Low-Re k - ϵ interface () as well as in the Turbulent Flow, SST interface (). The SST interface is suitable for many external flow cases and internal flows with sudden expansions. The standard k - ϵ turbulence model in the Turbulent Flow, k - ϵ interface () is computationally inexpensive compared to the other transport two-equation turbulence models but usually less accurate. The Algebraic y Plus and L-VEL interfaces are adapted for internal flows.

With the use of the CFD Module, additional turbulence models are available. The Realizable k - ϵ model is similar to the standard k - ϵ model but has built-in realizability constraints, resulting in improved performance for certain flows, such as turbulent jets. The k - ω model is an alternative to the standard k - ϵ model and often gives more accurate results, especially in recirculation regions and close to solid walls. However, the k - ω model is also less robust than the standard k - ϵ model. The Spalart–Allmaras interface is a dedicated physics interface for conjugate heat transfer in aerodynamics, for example, in the simulation of wing profiles. The $v2$ - f model includes near-wall turbulence anisotropy and is giving highly accurate results.

RADIATION

The heat transfer interfaces for radiation essentially belong to two different groups of radiation modeling: surface-to-surface radiation and radiation in participating or absorbing media.

The Heat Transfer with Surface-to-Surface Radiation multiphysics interface () combines the Heat Transfer in Solids interface with the Surface-to-Surface Radiation interface. It includes all functionality to model heat transfer in fluids or solids, including conduction and convection with surface-to-surface radiation.

The surface-to-surface radiation model also accounts for the dependency of surface properties on the spectral bands. For example, to model the greenhouse effect, it is necessary to solve separately for ambient radiation (large wavelengths) and the sun's radiation (small wavelengths). In addition, specular reflection can be considered instead of diffuse reflection. This is of particular interest for glossy surfaces made of polished aluminum or silver for example. Finally semitransparent layers can be modeled for configuration where a fraction of the radiation is going through a layer while the rest is reflected.



The Heat Transfer with Orbital Thermal Loads multiphysics interface () combines the Heat Transfer in Solids interface with the Orbital Thermal Loads interface. It is designed to model heat transfer including radiative loads on spacecraft, in particular radiation from the Sun and the Earth for satellites orbiting around Earth.

The Heat Transfer with Radiation in Participating Media multiphysics interface () combines the Heat Transfer in Solids interface with the Radiation in Participating Media interface. It includes all functionality to model conduction and convection in solids and fluids with radiation where absorption, emission, and scattering of radiation is accounted for by the radiation model.

For media that can be considered as nonemitting, the Heat Transfer with Radiation in Absorbing–Scattering Media multiphysics interface () combines the Heat Transfer in Solids interface with the Radiation in Absorbing–Scattering Media interface. For example, emission may be neglected when considering light diffusion.

For the modeling of collimated radiative beam propagating with no refraction, no reflection, and no scattering in a semitransparent medium that is supposed not to emit in the wavelength of the incident light, the Heat Transfer with Radiative Beam in Absorbing Media multiphysics interface () combines the Heat Transfer in Solids interface with the Radiative Beam in Absorbing Media interface. In cases where the temperature is an input of the model, more interfaces are available to compute only the radiative effects.

The Surface-to-Surface Radiation interface () describes systems where only radiation is computed, typically to estimate radiation between surfaces in space applications where the surface temperature is known.

The Radiation in Participating Media interface (), Radiation in Absorbing–Scattering Media interface (), and Radiative Beam in Absorbing Media interface () compute the radiation, with the possibility to include absorption, emission, and scattering effects, in a medium where the temperature is known.

ELECTROMAGNETIC HEATING

The Joule Heating interface () can combine the Electric Currents and Heat Transfer in Solids interfaces with capabilities for modeling Joule heating (resistive heating). This multiphysics coupling accounts for electromagnetic losses in the Heat Transfer interfaces as well as for the temperature dependency of material properties in the Electric Currents interface.

THIN STRUCTURES

The Thin Structures interfaces () provide efficient models defined at the boundaries level but that represent thin three-dimensional domains. Three different interfaces come with different default features.

The Heat Transfer in Shells interface () contains descriptions for heat transfer in shell structures where large temperature variations may be present. Thin conductive shells correspond to the simplest model, where the shell is represented as homogeneous and the temperature differences across the thickness of the structure material are neglected. Thin layered shells can represent a multilayered structure with heterogeneous material properties and compute the temperature variation across the shell sides. Typical examples of these structures are tanks, pipes, heat exchangers, airplane fuselages, and so forth. This physics interface can be combined with other Heat Transfer interfaces. For example, the Heat Transfer in Shells interface may be used to model the walls of a tank, while the Heat Transfer in Fluids interface may be used to model the fluid inside the tank. In many cases, using the Thin Layer boundary condition, found in the Heat Transfer interfaces, produces the easiest solution.

The Heat Transfer in Films interface () implements a model to describe the temperature field in films. The simplest model for thermally thin films assumes that the temperature changes through the film thickness can be neglected. This computationally effective model is sufficient in many cases. The general model computes the temperature variation across the film. Typical applications include when the sides of the film are exposed to different temperature or when heat is dissipated in the film.

The Heat Transfer in Fractures interface () describes heat transfer in a thin porous media. The simplest model assumes that the temperature changes through the fracture thickness can be neglected, while the general model computes the temperature variation across the fracture.

HEAT AND MOISTURE TRANSPORT

The Moist Air interface () combines the Heat Transfer in Moist Air interface with the Moisture Transport in Air interface. It is used to simulate the coupling

between heat transfer and vapor transport in air and the evaporation and condensation on walls.

The Moist Porous Media interface () combines the Heat Transfer in Moist Porous Media and Equilibrium Moisture Transport in Porous Media interfaces. It is used to simulate the coupling between heat transfer and moisture transport in liquid and gas phases in the pores of the medium.

The Building Materials interface () combines the Heat Transfer in Building interface with the Moisture Transport in Building Materials interface. It can be used to model different moisture variations phenomena in building components such as drying of initial construction moisture, condensation due to migration of moisture from outside to inside, or moisture accumulation by interstitial condensation due to diffusion.

HEAT AND MOISTURE FLOW

The Moisture Flow interfaces () combine all features from the Heat Transfer in Moist Air, Moisture Transport in Air and Single-Phase Flow interfaces. Three multiphysics couplings, Heat and Moisture Flow, Nonisothermal Flow, and Moisture Flow, are also automatically added.

The Moisture Flow interfaces () are used to compute the temperature and relative humidity distribution in air along with the velocity and pressure fields. This multiphysics coupling is available for the different turbulent flow models.

MOISTURE TRANSPORT

The Moisture Transport in Air interface () is used to compute the relative humidity distribution in air. It simulates moisture transport by vapor convection and diffusion in moist air and the evaporation or condensation on walls.

The Equilibrium Moisture Transport in Porous Media interface () is used to compute the relative humidity field in porous media. It simulates moisture transport by vapor convection and diffusion in the gas phase, liquid water transport by convection and capillarity in the pores of the media. A Hygroscopic Porous Medium feature with an equilibrium formulation is active by default on all domains.

The Nonequilibrium Moisture Transport in Porous Media interface () is used to compute the relative humidity and liquid water saturation fields in porous media. It simulates moisture transport by vapor convection and diffusion in the gas phase, liquid water transport by convection and capillarity in the pores of the media. A Hygroscopic Porous Medium feature with a nonequilibrium formulation is active by default on all domains.

The Moisture Transport in Building Materials interface () is used to compute the relative humidity field in building materials. It simulates moisture transport by

taking into account moisture storage, liquid transport by capillary suction forces, and convective transport of vapor.

The Moisture Transport in Free and Porous Media interface () is used to compute the relative humidity field in all domains, and additionally the liquid water saturation in porous media. It simulates moisture transport by vapor convection and diffusion in the gas phase, liquid water transport by convection and capillarity in the pores of the media. A Moist Air feature is active by default on all domains, and a Hygroscopic porous Medium is added by default with no selection. This interface handles all types of interface between free and porous media, and between two porous media.

The Moisture Transport in Solids interface () is used to compute the relative humidity and moist air pressure in porous media. It simulates moisture transport by vapor convection and diffusion in the gas phase and liquid water transport by convection and capillarity in the pores of the medium.

MOISTURE FLOW

The Moisture Flow interfaces () combine all features from the Moisture Transport in Air and Single-Phase Flow interfaces. The Moisture Flow multiphysics coupling is automatically added. It couples the moisture transfer and fluid flow interfaces. The fluid properties may depend on vapor concentration. Models can also include moisture transport in building materials. The physics interface supports low Mach numbers (typically less than 0.3). Similarly to Conjugate Heat Transfer coupling, the moisture transport interface can be coupled with one of the turbulent flow interface.

If a module providing the Brinkman Equations interface is available, the Porous Media Flow coupling is also available. It couples moisture transport in porous media and fluid flow by the Brinkman equations.

POROUS MEDIA

The Heat Transfer in Porous Media interface () combines conduction in a porous matrix and in the fluid contained in the pore structure with the convection of heat generated by the flow of the fluid. This physics interface uses the provided power law or a user-defined expression for the effective heat transfer properties, and a predefined expression for dispersion in porous media. Dispersion is caused by the tortuous path of the liquid in the porous media. (This would be absent if the mean convective term was accounted for.) This physics interface may be used for a wide range of porous materials, from porous structures in the pulp and paper industry to the simulation of heat transfer in soil and rocks.







The Local Thermal Nonequilibrium (LTNE) interface () implements a macroscale model designed to simulate heat transfer in porous media where the









temperatures in the porous matrix and the fluid are not in equilibrium. It differs from simpler macroscale models for heat transfer in porous media where the temperature difference between the solid and fluid is neglected. The absence of thermal equilibrium can result from fast transient changes, but it can also be observed in stationary cases. Typical applications are rapid heating of a porous media using a hot fluid or internal heat generation in one of the phases (due to inductive or microwave heating, exothermic reactions, and so on). This is observed in nuclear devices, electronics systems, or fuel cells for example.

The Heat Transfer in Packed Beds interface () provides a multiscale model for heat transfer in a porous medium where the local thermal equilibrium is not assumed between the pellets of a packed bed and the fluid phase, and where the temperature variation inside the pellets is taken into account. A temperature field is defined for each phase, pellets and fluid of the porous medium, and the heat transfer between them is accounted for. The microscale pellets temperature field depends on the radial coordinate of each pellet.















Physics Interface Guide by Space Dimension and Study Type











The table lists additional physics interfaces that become available upon adding the Heat Transfer Module to the COMSOL Multiphysics simulation platform.

PHYSICS INTERFACE	ICON	TAG	SPACE DIMENSION	AVAILABLE STUDY TYPE
 Chemical Species Transport				
Transport of Diluted Species ¹		tds	all dimensions	stationary; time dependent
 Moisture Transport				
Moisture Transport in Air		mt	all dimensions	stationary; time dependent
Equilibrium Moisture Transport in Porous Media		mt	all dimensions	stationary; time dependent
Nonequilibrium Moisture Transport in Porous Media		mt	all dimensions	stationary; time dependent
Moisture Transport in Building Materials		mt	all dimensions	stationary; time dependent











PHYSICS INTERFACE	ICON	TAG	SPACE DIMENSION	AVAILABLE STUDY TYPE
Moisture Transport in Free and Porous Media		mt	all dimensions	stationary; time dependent
Moisture Transport in Solids		mts	all dimensions	stationary; time dependent
 Moisture Flow				
Laminar Flow ⁽²⁾		—	3D, 2D, 2D axisymmetric	stationary; time dependent; stationary, one-way Moisture Flow; time dependent, one-way Moisture Flow
 Turbulent Flow				
Turbulent Flow, Algebraic γ Plus ⁽²⁾		—	3D, 2D, 2D axisymmetric	stationary with initialization; time dependent with initialization; stationary with initialization, one-way Moisture Flow; time dependent with initialization, one-way Moisture Flow
Turbulent Flow, L-VEL ⁽²⁾		—	3D, 2D, 2D axisymmetric	stationary with initialization; time dependent with initialization; stationary with initialization, one-way Moisture Flow; time dependent with initialization, one-way Moisture Flow
Turbulent Flow, $k-\epsilon$ ⁽²⁾		—	3D, 2D, 2D axisymmetric	stationary; time dependent; stationary, one-way Moisture Flow; time dependent, one-way Moisture Flow
Turbulent Flow, Realizable $k-\epsilon$ ^(2,3)		—	3D, 2D, 2D axisymmetric	stationary; time dependent; stationary, one-way Moisture Flow; time dependent, one-way Moisture Flow













PHYSICS INTERFACE	ICON	TAG	SPACE DIMENSION	AVAILABLE STUDY TYPE
Turbulent Flow, $k-\omega$ ^(2,3)		—	3D, 2D, 2D axisymmetric	stationary with initialization; time dependent with initialization; stationary with initialization, one-way Moisture Flow; time dependent with initialization, one-way Moisture Flow
Turbulent Flow, SST ⁽²⁾		—	3D, 2D, 2D axisymmetric	stationary with initialization; time dependent with initialization; stationary with initialization, one-way Moisture Flow; time dependent with initialization, one-way Moisture Flow
Turbulent Flow, Low Re $k-\epsilon$ ⁽²⁾		—	3D, 2D, 2D axisymmetric	stationary with initialization; time dependent with initialization; stationary with initialization, one-way Moisture Flow; time dependent with initialization, one-way Moisture Flow
Turbulent Flow, Spalart–Allmaras ^(2,3)		—	3D, 2D, 2D axisymmetric	stationary with initialization; time dependent with initialization; stationary with initialization, one-way Moisture Flow; time dependent with initialization, one-way Moisture Flow
Turbulent Flow, v_2-f ^(2,3)		—	3D, 2D, 2D axisymmetric	stationary with initialization; time dependent with initialization; stationary with initialization, one-way Moisture Flow; time dependent with initialization, one-way Moisture Flow
Porous Media Flow ^(2,3)		—	3D, 2D, 2D axisymmetric	stationary; time dependent; stationary, one-way Moisture Flow; time dependent, one-way Moisture Flow











PHYSICS INTERFACE	ICON	TAG	SPACE DIMENSION	AVAILABLE STUDY TYPE
 Reacting Flow				
Laminar Flow, Diluted Species ¹		—	3D, 2D, 2D axisymmetric	stationary; time dependent
 Turbulent Flow, Diluted Species				
Turbulent Flow, k-ε		—	3D, 2D, 2D axisymmetric	stationary; time dependent
Turbulent Flow, k-ω ⁽³⁾		—	3D, 2D, 2D axisymmetric	stationary; time dependent
Turbulent Flow, SST		—	3D, 2D, 2D axisymmetric	stationary with initialization; time dependent with initialization
Turbulent Flow, Low Re k-ε		—	3D, 2D, 2D axisymmetric	stationary with initialization; time dependent with initialization
 Fluid Flow				
 Single-Phase Flow				
Laminar Flow ¹		spf	3D, 2D, 2D axisymmetric	stationary; time dependent
 Turbulent Flow				
Turbulent Flow, Algebraic γPlus		spf	3D, 2D, 2D axisymmetric	stationary with initialization; time dependent with initialization
Turbulent Flow, L-VEL		spf	3D, 2D, 2D axisymmetric	stationary with initialization; time dependent with initialization
Turbulent Flow, k-ε		spf	3D, 2D, 2D axisymmetric	stationary; time dependent
Turbulent Flow, SST		spf	3D, 2D, 2D axisymmetric	stationary with initialization; time dependent with initialization

PHYSICS INTERFACE	ICON	TAG	SPACE DIMENSION	AVAILABLE STUDY TYPE
Turbulent Flow, Low Re k- ϵ		spf	3D, 2D, 2D axisymmetric	stationary with initialization; time dependent with initialization
 Nonisothermal Flow				
Laminar Flow ^(1,2)		—	3D, 2D, 2D axisymmetric	stationary; time dependent; Stationary, one-way NITF; time dependent, one-way NITF
 Turbulent Flow				
Turbulent Flow, Algebraic γ Plus ⁽²⁾		—	3D, 2D, 2D axisymmetric	stationary with initialization; time dependent with initialization; Stationary, one-way NITF; time dependent, one-way NITF
Turbulent Flow, L-VEL ⁽²⁾		—	3D, 2D, 2D axisymmetric	stationary with initialization; time dependent with initialization; Stationary, one-way NITF; time dependent, one-way NITF
Turbulent Flow, k- ϵ ⁽²⁾		—	3D, 2D, 2D axisymmetric	stationary; time dependent; Stationary, one-way NITF; time dependent, one-way NITF
Turbulent Flow, Realizable k- ϵ ^(2,3)		—	3D, 2D, 2D axisymmetric	stationary; time dependent; Stationary, one-way NITF; time dependent, one-way NITF
Turbulent Flow, k- ω ^(2,3)		—	3D, 2D, 2D axisymmetric	stationary; time dependent; Stationary, one-way NITF; time dependent, one-way NITF
Turbulent Flow, SST ⁽²⁾		—	3D, 2D, 2D axisymmetric	stationary with initialization; time dependent with initialization; Stationary, one-way NITF; time dependent, one-way NITF



PHYSICS INTERFACE	ICON	TAG	SPACE DIMENSION	AVAILABLE STUDY TYPE
Turbulent Flow, Low Re $k-\epsilon^{(2)}$		—	3D, 2D, 2D axisymmetric	stationary with initialization; time dependent with initialization; Stationary, one-way NITF; time dependent, one-way NITF
Turbulent Flow, Spalart–Allmaras ^(2,3)		—	3D, 2D, 2D axisymmetric	stationary with initialization; time dependent with initialization; Stationary, one-way NITF; time dependent, one-way NITF
Turbulent Flow, $\nu_2-f^{(2,3)}$		—	3D, 2D, 2D axisymmetric	stationary with initialization; time dependent with initialization; Stationary, one-way NITF; time dependent, one-way NITF
Turbulent Flow, Wilcox $R-\omega^{(2,3)}$		—	3D, 2D, 2D axisymmetric	stationary; time dependent; Stationary, one-way NITF; time dependent, one-way NITF
Turbulent Flow, SSG-LRR ^(2,3)		—	3D, 2D, 2D axisymmetric	stationary; time dependent; Stationary, one-way NITF; time dependent, one-way NITF
Turbulent Flow, Elliptic Blending $R-\epsilon^{(2,3)}$		—	3D, 2D, 2D axisymmetric	stationary; time dependent; Stationary, one-way NITF; time dependent, one-way NITF
 Heat Transfer				
Heat Transfer in Solids ¹		ht	all dimensions	stationary; time dependent; thermal perturbation, frequency domain; thermal perturbation, eigenfrequency
Heat Transfer in Fluids ¹		ht	all dimensions	stationary; time dependent; thermal perturbation, frequency domain; thermal perturbation, eigenfrequency







PHYSICS INTERFACE	ICON	TAG	SPACE DIMENSION	AVAILABLE STUDY TYPE
Heat Transfer in Solids and Fluids ¹		ht	all dimensions	stationary; time dependent; thermal perturbation, frequency domain; thermal perturbation, eigenfrequency
 Conjugate Heat Transfer				
Laminar Flow ^(1,2)		—	3D, 2D, 2D axisymmetric	stationary; time dependent; Stationary, one-way NITF; time dependent, one-way NITF
 Turbulent Flow				
Turbulent Flow, Algebraic γ Plus ⁽²⁾		—	3D, 2D, 2D axisymmetric	stationary with initialization; time dependent with initialization; Stationary, one-way NITF; time dependent, one-way NITF
Turbulent Flow, L-VEL ⁽²⁾		—	3D, 2D, 2D axisymmetric	stationary with initialization; time dependent with initialization; Stationary, one-way NITF; time dependent, one-way NITF
Turbulent Flow, $k-\epsilon$ ⁽²⁾		—	3D, 2D, 2D axisymmetric	stationary; time dependent; Stationary, one-way NITF; time dependent, one-way NITF
Turbulent Flow, Realizable $k-\epsilon$ ^(2,3)		—	3D, 2D, 2D axisymmetric	stationary; time dependent; Stationary, one-way NITF; time dependent, one-way NITF
Turbulent Flow, $k-\omega$ ^(2,3)		—	3D, 2D, 2D axisymmetric	stationary; time dependent; Stationary, one-way NITF; time dependent, one-way NITF
Turbulent Flow, SST ⁽²⁾		—	3D, 2D, 2D axisymmetric	stationary with initialization; time dependent with initialization; Stationary, one-way NITF; time dependent, one-way NITF

PHYSICS INTERFACE	ICON	TAG	SPACE DIMENSION	AVAILABLE STUDY TYPE
Turbulent Flow, Low Re $k-\epsilon^{(2)}$		—	3D, 2D, 2D axisymmetric	stationary with initialization; time dependent with initialization; Stationary, one-way NITF; time dependent, one-way NITF
Turbulent Flow, Spalart–Allmaras ^(2,3)		—	3D, 2D, 2D axisymmetric	stationary with initialization; time dependent with initialization; Stationary, one-way NITF; time dependent, one-way NITF
Turbulent Flow, $v2-f^{(2,3)}$		—	3D, 2D, 2D axisymmetric	stationary with initialization; time dependent with initialization; Stationary, one-way NITF; time dependent, one-way NITF
 Radiation				
Heat Transfer with Surface-to-Surface Radiation		—	all dimensions	stationary; time dependent; thermal perturbation, frequency domain
Heat Transfer with Orbital Thermal Loads		—	3D	time dependent
Heat Transfer with Radiation in Participating Media		—	3D, 2D, 2D axisymmetric	stationary; time dependent; thermal perturbation, frequency domain
Heat Transfer with Radiation in Absorbing–Scattering Media		—	3D, 2D, 2D axisymmetric	stationary; time dependent; thermal perturbation, frequency domain
Heat Transfer with Radiative Beam in Absorbing Media		—	3D, 2D, 2D axisymmetric	stationary; time dependent; thermal perturbation, frequency domain
Surface-to-Surface Radiation		rad	all dimensions	stationary; time dependent
Orbital Thermal Loads		otl	3D	time dependent
Radiation in Participating Media		rpm	3D, 2D, 2D axisymmetric	stationary; time dependent

PHYSICS INTERFACE	ICON	TAG	SPACE DIMENSION	AVAILABLE STUDY TYPE
Radiation in Absorbing–Scattering Media		rasm	3D, 2D, 2D axisymmetric	stationary; time dependent
Radiative Beam in Absorbing Media		rbam	3D, 2D, 2D axisymmetric	stationary; time dependent
 Electromagnetic Heating				
Joule Heating ^{1,2}		—	all dimensions	stationary; time dependent; thermal perturbation, frequency domain; thermal perturbation, eigenfrequency
Lumped Thermal System		lts	all dimensions	stationary; time dependent
 Thin Structures				
Heat Transfer in Shells		htlsh	3D, 2D, 2D axisymmetric	stationary; time dependent; thermal perturbation, frequency domain; thermal perturbation, eigenfrequency
Heat Transfer in Films		htlsh	3D, 2D, 2D axisymmetric	stationary; time dependent; thermal perturbation, frequency domain; thermal perturbation, eigenfrequency
Heat Transfer in Fractures		htlsh	3D, 2D, 2D axisymmetric	stationary; time dependent; thermal perturbation, frequency domain; thermal perturbation, eigenfrequency
 Heat and Moisture Transport				
Moist Air ⁽²⁾		—	all dimensions	stationary; time dependent; thermal perturbation, frequency domain; thermal perturbation, eigenfrequency

PHYSICS INTERFACE	ICON	TAG	SPACE DIMENSION	AVAILABLE STUDY TYPE
Moist Porous Media ⁽²⁾		—	all dimensions	stationary; time dependent; thermal perturbation, frequency domain; thermal perturbation, eigenfrequency
Building Materials ⁽²⁾		—	all dimensions	stationary; time dependent; thermal perturbation, frequency domain; thermal perturbation, eigenfrequency
 Heat and Moisture Flow				
Laminar Flow ⁽²⁾		—	3D, 2D, 2D axisymmetric	stationary; time dependent; stationary, one-way Moisture Flow; time dependent, one-way Moisture Flow
 Turbulent Flow				
Turbulent Flow, Algebraic γ Plus ⁽²⁾		—	3D, 2D, 2D axisymmetric	stationary with initialization; time dependent with initialization; stationary with initialization, one-way Moisture Flow; time dependent with initialization, one-way Moisture Flow
Turbulent Flow, L-VEL ⁽²⁾		—	3D, 2D, 2D axisymmetric	stationary with initialization; time dependent with initialization; stationary with initialization, one-way Moisture Flow; time dependent with initialization, one-way Moisture Flow
Turbulent Flow, $k-\epsilon$ ⁽²⁾		—	3D, 2D, 2D axisymmetric	stationary; time dependent; stationary, one-way Moisture Flow; time dependent, one-way Moisture Flow

PHYSICS INTERFACE	ICON	TAG	SPACE DIMENSION	AVAILABLE STUDY TYPE
Turbulent Flow, Realizable $k-\epsilon$ ^(2,3)		—	3D, 2D, 2D axisymmetric	stationary; time dependent; stationary, one-way Moisture Flow; time dependent, one-way Moisture Flow
Turbulent Flow, $k-\omega$ ^(2,3)		—	3D, 2D, 2D axisymmetric	stationary with initialization; time dependent with initialization; stationary with initialization, one-way Moisture Flow; time dependent with initialization, one-way Moisture Flow
Turbulent Flow, SST ⁽²⁾		—	3D, 2D, 2D axisymmetric	stationary with initialization; time dependent with initialization; stationary with initialization, one-way Moisture Flow; time dependent with initialization, one-way Moisture Flow
Turbulent Flow, Low Re $k-\epsilon$ ⁽²⁾		—	3D, 2D, 2D axisymmetric	stationary with initialization; time dependent with initialization; stationary with initialization, one-way Moisture Flow; time dependent with initialization, one-way Moisture Flow
Turbulent Flow, Spalart–Allmaras ^(2,3)		—	3D, 2D, 2D axisymmetric	stationary with initialization; time dependent with initialization; stationary with initialization, one-way Moisture Flow; time dependent with initialization, one-way Moisture Flow
Turbulent Flow, v_2-f ^(2,3)		—	3D, 2D, 2D axisymmetric	stationary with initialization; time dependent with initialization; stationary with initialization, one-way Moisture Flow; time dependent with initialization, one-way Moisture Flow

PHYSICS INTERFACE	ICON	TAG	SPACE DIMENSION	AVAILABLE STUDY TYPE
Porous Media Flow ^(2,3)		—	3D, 2D, 2D axisymmetric	stationary; time dependent; stationary, one-way Moisture Flow; time dependent, one-way Moisture Flow
 Porous Media				
Heat Transfer in Porous Media		ht	all dimensions	stationary; time dependent; thermal perturbation, frequency domain; thermal perturbation, eigenfrequency
Local Thermal Nonequilibrium		ht	all dimensions	stationary; time dependent; thermal perturbation, frequency domain; thermal perturbation, eigenfrequency
Heat Transfer in Packed Beds		ht	all dimensions	stationary; time dependent; thermal perturbation, frequency domain; thermal perturbation, eigenfrequency
Bioheat Transfer		ht	all dimensions	stationary; time dependent; thermal perturbation, frequency domain; thermal perturbation, eigenfrequency
Thermoelectric Effect ²		—	all dimensions	stationary; time dependent; thermal perturbation, frequency domain; thermal perturbation, eigenfrequency

¹ This physics interface is included with the core COMSOL package but has added functionality for this module.

² This physics interface is a predefined multiphysics coupling that automatically adds all the physics interfaces and coupling features required.

³ Requires the addition of the CFD Module.

Tutorial Model — Electronic Chip Cooling

This model is an introduction to simulations of device cooling. A device (here a chip associated to a heat sink) is cooled by a surrounding fluid, air in this case. This tutorial demonstrates the following important steps:

- Defining a heat rate on a domain using automatic volume computation.
- Modeling the temperature difference between two surfaces when a thermally thick layer is present.
- Including the radiative heat transfer between surfaces in a model.

In addition, this tutorial compares two approaches for modeling the air cooling. First, only the solid is represented and a convective cooling heat flux boundary condition is used to account for the heat transfer between the solid and the fluid. In a second step, the air domain is included in the model and a nonisothermal flow model is defined.

Model Definition

The modeled system describes an aluminum heat sink used for the cooling of an electronic chip, as shown in [Figure 10](#).

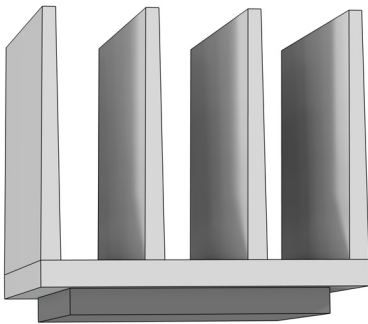

Figure 10: Heat sink and electronic chip geometry.

The heat sink represented in gray in [Figure 10](#) is mounted inside a channel with a rectangular cross section. Such a setup is used to measure the cooling capacity of heat sinks. Air enters the channel at the inlet and exits the channel at the outlet. Thermal grease is used to improve the thermal contact between the base of the heat sink and the top surface of the electronic component. All other external faces are thermally insulated. The heat dissipated by the electronic component is equal to 10 W and is distributed through the chip volume.

The cooling capacity of the heat sink can be determined by monitoring the temperature in the electronic component.

The model solves a thermal balance for the electronic component, heat sink, and air flowing in the rectangular channel. Thermal energy is transferred by conduction in the electronic component and the aluminum heat sink. Thermal energy is transported by conduction and advection in the cooling air. Unless an efficient thermal grease is used to improve the thermal contact between the electronic component and the heat sink, the temperature field varies significantly there. The temperature is set at the inlet of the channel. The transport of thermal energy at the outlet is dominated by convection.

Initially, heat transfer by radiation between surfaces is neglected. This assumption is valid as the surfaces have low emissivity (close to 0), which is usually the case for polished metals. In a case where the surface emissivity is large (close to 1), the surface-to-surface radiation should be considered. This is done later in this tutorial, where the model is modified to account for surface-to-surface radiation at the channel walls and heat sink boundaries. Assuming that the surfaces have been treated with black paint, the surface emissivity is close to 1 in this second case.

The flow field is obtained by solving one momentum balance relation for each space coordinate (x , y , and z) and a mass balance equation. The inlet velocity is defined by a parabolic velocity profile for fully developed laminar flow. At the outlet, the normal stress is equal to the outlet pressure and the tangential stress is canceled. At all solid surfaces, the velocity is set to zero in all three spatial directions.

The thermal conductivity of air, heat capacity of air, and air density are all temperature-dependent material properties. You can find all of the settings in the physics interface for Conjugate Heat Transfer in COMSOL Multiphysics. The material properties, including their temperature dependence, are available in the Material Browser.

Results with Convective Cooling Boundary Condition

In this part of the model, only the solid domains are represented. Instead of computing the flow velocity, pressure, and temperature in the air channel, a convective cooling boundary condition is used at the heat sink boundaries. The approach enables very quick computations, but its accuracy relies on the heat transfer coefficient that is used to define the convective cooling condition. In this configuration, an empirical value, $10 \text{ W}/(\text{m}^2\cdot\text{K})$, is used.

Next, to model the thermal contact between the heat sink and the chip three hypotheses are considered. In a first simulation an ideal contact is assumed.

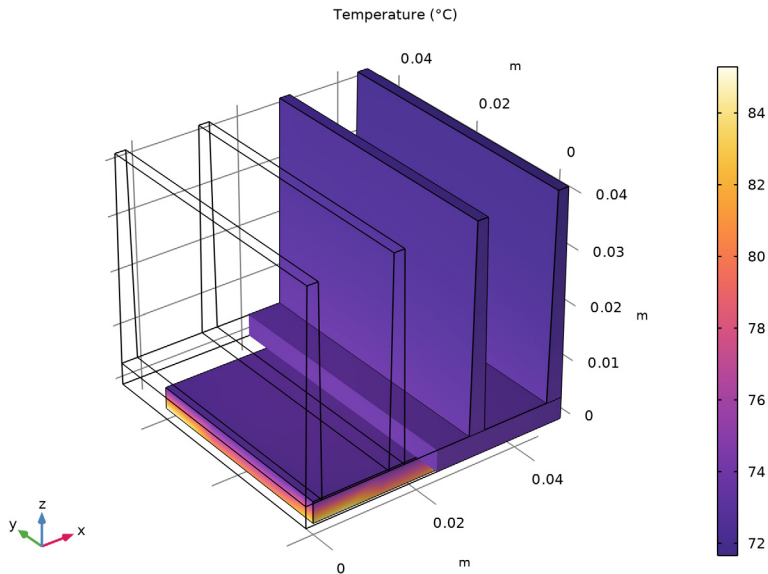

Figure 11: Temperature on half of heat sink surface and on the chip surface assuming perfect thermal contact.

Under ideal conditions, the maximum temperature in the chip is about 85°C.

In the second simulation, a 50- μm -thick layer of air between the heat sink and the chip is assumed to create a thermal resistance.

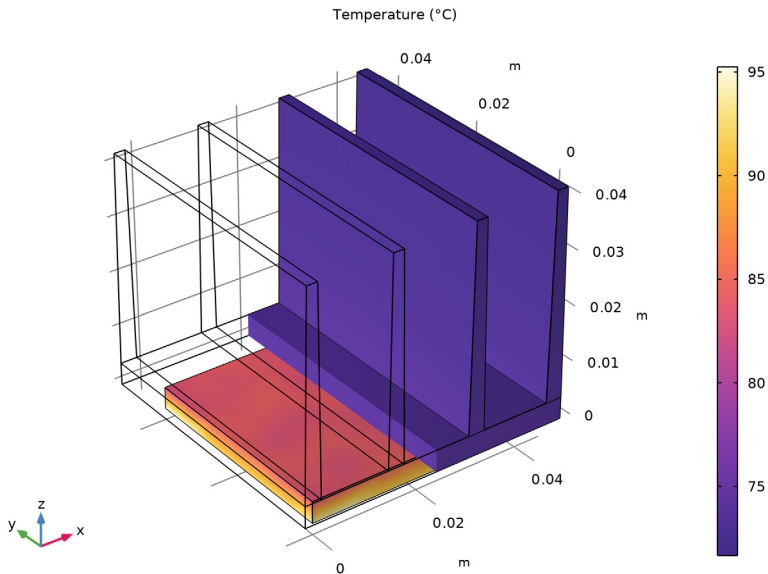

Figure 12: The surface plot shows the temperature on half of heat sink surface and on the chip surface accounting for a thin air layer between the heat sink and the chip.

The thermal resistance decreases the performance of the heat sink and the maximum temperature is close to 95°C.

Finally, a third configuration is tested where the thin layer contains thermal grease instead of air.

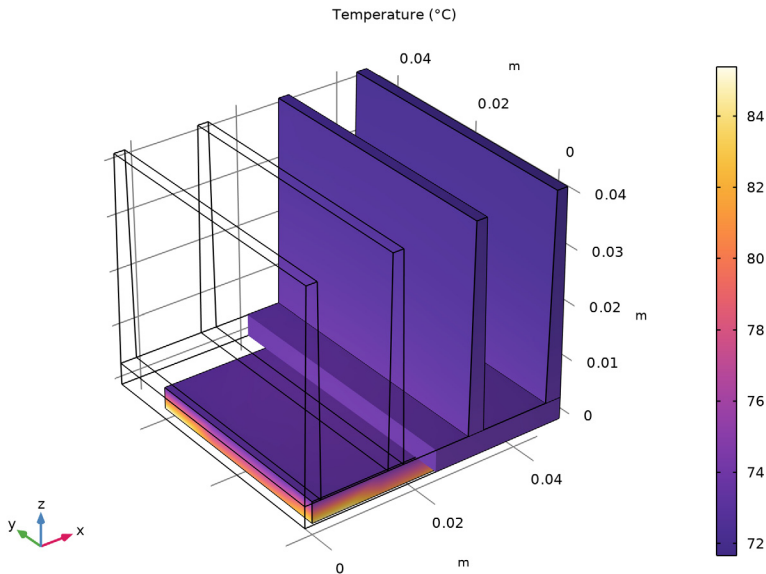

Figure 13: The surface plot shows the temperature on half of heat sink surface and on the chip surface accounting for a thin thermal grease layer between the heat sink and the chip.

The maximum temperature is close to the one observed in the first configuration with an ideal thermal contact. This means that the effect of the thermal resistance is greatly reduced by the thermal grease, which has a higher thermal conductivity than air.

Results with Nonisothermal Flow in the Channel

Since the heat transfer coefficient is in general unknown, an alternative approach is suitable. In this part, a domain corresponding to the air channel is added to the geometry in order to compute the flow and the temperature field in the air. This leads to more computationally expensive simulations, but the approach is more general.

In [Figure 14](#), the hot wake behind the heat sink is a sign of the convective cooling effects. The maximum temperature, reached in the electronic component, is about 85°C.

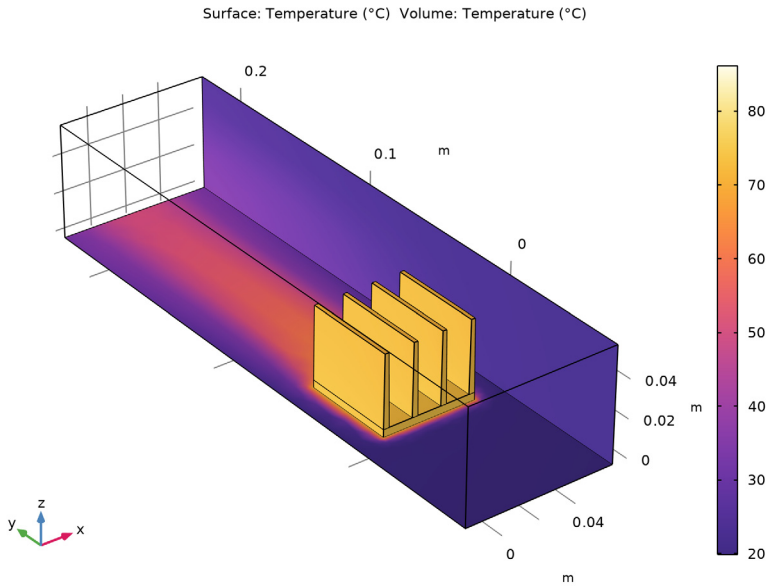

Figure 14: The surface plot shows the temperature field on the channel walls and the heat sink surface.

Compared with the first approach (without the air domain), the results are different. This shows that using a heat transfer coefficient that is not known with accuracy, as in the first approach, provides good orders of magnitude but can still be approximate.

In the second step, the temperature and velocity fields are obtained when surface-to-surface radiation is included and the surface emissivities are large.

[Figure 15](#) shows that the maximum temperature, about 75°C, is decreased by

about 10 °C when compared to the first case in [Figure 14](#). This confirms that radiative heat transfer is not negligible when the surface emissivity is close to 1.

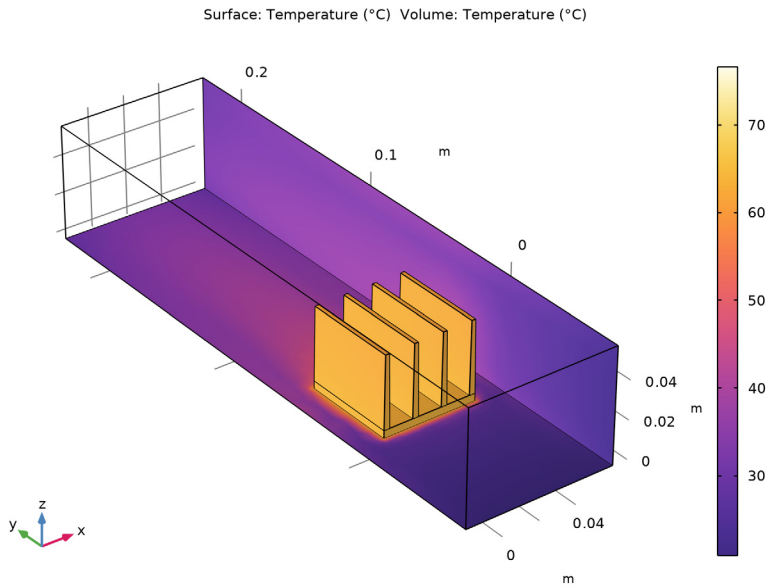



Figure 15: The effects of surface-to-surface radiation on temperature. The surface plot shows the temperature field on the channel walls and the heat sink surface.



Model Wizard

Note: These instructions are for the user interface on Windows[®] but also apply, with minor differences, to Linux[®] and macOS.

- 1 To start the software, double-click the COMSOL icon on the desktop. When the software opens, you can choose to use the Model Wizard to create a new COMSOL Multiphysics model or a Blank Model to create one manually. For this tutorial, click the Model Wizard button.

If COMSOL Multiphysics is already open, you can start the Model Wizard by selecting New  from the File menu and then click Model Wizard .

The Model Wizard guides you through the first steps of setting up a model. The next window lets you select the dimension of the modeling space.

- 2 In the Select Space Dimension window click 3D .
- 3 In the Select Physics tree, under Heat Transfer click Heat Transfer in Solids and Fluids .

In the first part of this tutorial heat transfer is modeled only in the solid part, hence the predefined node for the fluid domains remains with an empty selection. The fluid node is used for the fluid domains in the second part of this tutorial when the air domain is added.

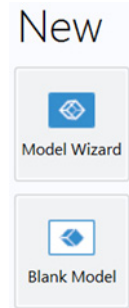

4 Click Add and then  Study to continue.

Select Physics

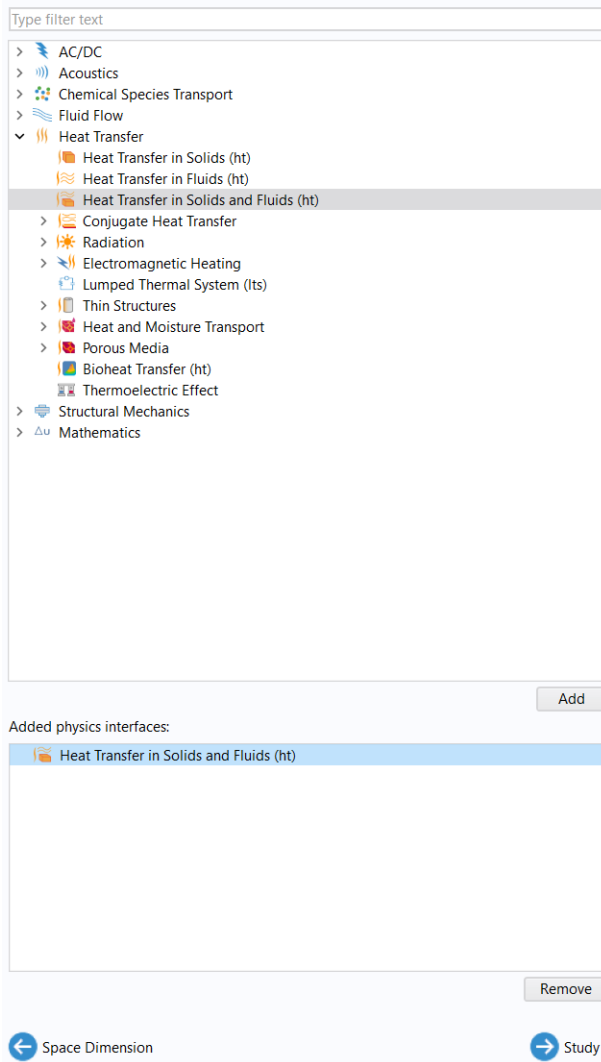

Type filter text



- > AC/DC
- > Acoustics
- > Chemical Species Transport
- > Fluid Flow
- ▼ Heat Transfer
 - Heat Transfer in Solids (ht)
 - Heat Transfer in Fluids (ht)
 - Heat Transfer in Solids and Fluids (ht)
- > Conjugate Heat Transfer
- > Radiation
- > Electromagnetic Heating
- Lumped Thermal System (Its)
- > Thin Structures
- > Heat and Moisture Transport
- > Porous Media
- Bioheat Transfer (ht)
- Thermoelectric Effect
- > Structural Mechanics
- > Δu Mathematics

Add

Added physics interfaces:

- Heat Transfer in Solids and Fluids (ht)

Remove

 Space Dimension  Study

5 Under General Studies click Stationary .

6 Click Done .





Preset Studies have solver and equation settings adapted to the selected physics interface (in this example, Heat Transfer in Solids). A Stationary study is used in this case—there is no time-varying heat source or cooling condition.

Geometry I

First import parameters that will be used in the model set up.

Note: The exact location of the files used in this exercise may vary based on the installation. For example, if the installation is on your hard drive, the file path might be similar to

C:\Program Files\COMSOL\COMSOL64\Multiphysics\applications\Heat_Transfer_Module\Tutorials,_Forced_and_Natural_Convection\

- 1 In the Home toolbar, click Parameters  and select Parameters 1.
- 2 In the Settings window for Parameters, locate the Parameters section.
- 3 Click Load from File .
- 4 Browse to the model's Application Libraries folder and double-click the file chip_cooling.txt.
- 5 In the Geometry toolbar, click Block .
- 6 In the Settings window for Block, locate the Size and Shape section.
- 7 In the Width text field, type L_chip.
- 8 In the Depth text field, type L_chip.
- 9 In the Height text field, type H_chip.
- 10 Locate the Position section. In the z text field, type -H_chip.
- 11 Click Build Selected .
- 12 In the Geometry toolbar, click Part Libraries .

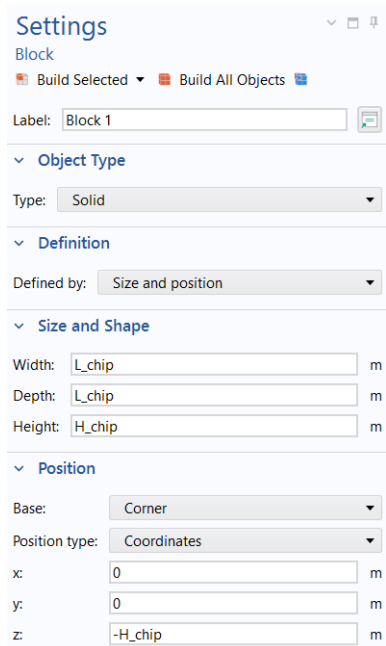

- 13 In the Part Libraries window, select Heat Transfer Module > Heat Sinks > heat sink straight fins in the tree.

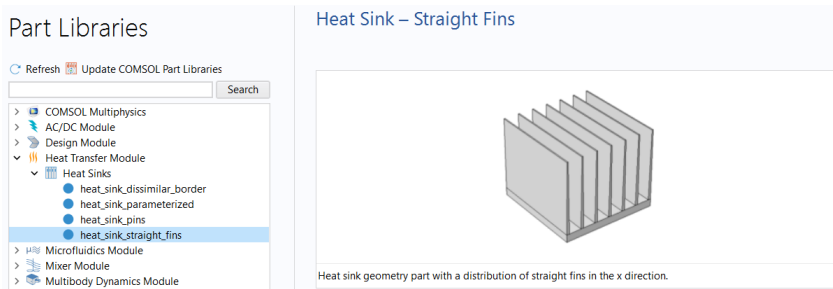

- 14 Click Add to Geometry .

- 15 In the Model Builder window, under Component 1 (comp1) > Geometry 1 click Heat Sink - Straight Fins 1 (pi1).

- 16 In the Settings window for Part Instance, locate the row for the parameter `n_fins_x` in the Input Parameters section and enter `n_fins` as value expression. Then define `X_fins_bottom` and `X_fins_top` to `3[mm]` and `2[mm]` respectively.

Input Parameters

Name	Expression	Value	Description
X_base	50[mm]	0.05 m	Base dimension in x direction
Y_base	50[mm]	0.05 m	Base dimension in y direction
Z_base	4[mm]	0.004 m	Base dimension in z direction
n_fins_x	n_fins	4	Amount of fins in x direction
X_fins_bottom	3[mm]	0.003 m	Fin dimension in x direction, bottom
X_fins_top	2[mm]	0.002 m	Fin dimension in x direction, top
Z_fins	38[mm]	0.038 m	Fin height
o_x	0[mm]	0 m	Border offset in x direction
o_y	0[mm]	0 m	Border offset in y direction
fillet_top	0	0	Fillet on top: 1-Enabled, 0-Disabled
fillet_bottom	0	0	Fillet on bottom: 1-Enabled, 0-Disab...

- 17 Locate the Position and Orientation of Output section. Find the Coordinate system in part subsection. From the Work plane in part list, choose Work plane for heat sink base (wp11).

18 In the Displacement subsection, type -5 [mm] in the xw and yw text fields.

Position and Orientation of Output

Coordinate system in part

Work plane in part: Work plane for heat sink base (wp11)

Coordinate system to match

Take work plane from: This sequence

Work plane: xy-plane

Displacement

xwi: -5[mm] m

ywi: -5[mm] m

zwi: 0 m

19 Click to expand the Domain Selections section. For row number 4 labeled A1.1 in the table, click to select the Keep checkbox to make the domain selection available in the physics interfaces. This selection corresponds to all the geometrical domains of the heat sink.

Domain Selections

Name	Keep	Physics	Contribute to
Heat sink base	<input type="checkbox"/>	<input checked="" type="checkbox"/>	None
Step domain	<input type="checkbox"/>	<input checked="" type="checkbox"/>	None
Array of fins	<input type="checkbox"/>	<input checked="" type="checkbox"/>	None
All	<input checked="" type="checkbox"/>	<input checked="" type="checkbox"/>	None

New Cumulative Selection

20 Click to collapse the Domain Selections section.

21 Click to expand the Boundary Selections section. For row number 3 labeled Exterior boundaries without heat sink base in the table, click to select the Keep checkbox.

Boundary Selections

Name	Keep	Physics	Contribute to
Bottom boundary	<input type="checkbox"/>	<input checked="" type="checkbox"/>	None
Exterior	<input type="checkbox"/>	<input checked="" type="checkbox"/>	None
Exterior boundaries without heat sink...	<input checked="" type="checkbox"/>	<input checked="" type="checkbox"/>	None
All	<input type="checkbox"/>	<input checked="" type="checkbox"/>	None

New Cumulative Selection

22 Click to collapse the Boundary Selections section.

23 In the Geometry toolbar, click Build All .

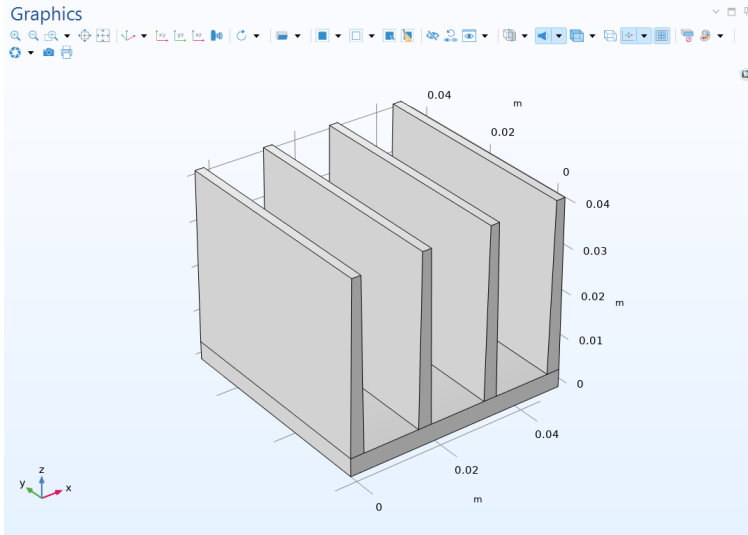

24 In the Graphics toolbar, click the Zoom Extents button .



Materials



Now define the materials that will be used in the first study.

Aluminum

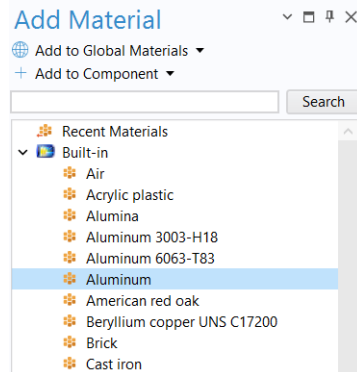
- 1 In the Home toolbar, click Add Material .
- 2 Go to the Add Material window.
- 3 In the tree, select Built-In > Aluminum.
- 4 Click Add to Component .



Silica Glass

- 1 Select now Built-In > Silica glass and click Add to Component .
- 2 In the Home toolbar, click again Add Material  to close the material panel.

To facilitate face selection in the next steps, use the Wireframe Rendering option by clicking the Wireframe Rendering button  in the Graphics toolbar.

- 3 In the Model Builder window, under Component 1 (comp1) > Materials click Silica glass (mat2).
- 4 Select Domain 3 corresponding to the electronic chip.

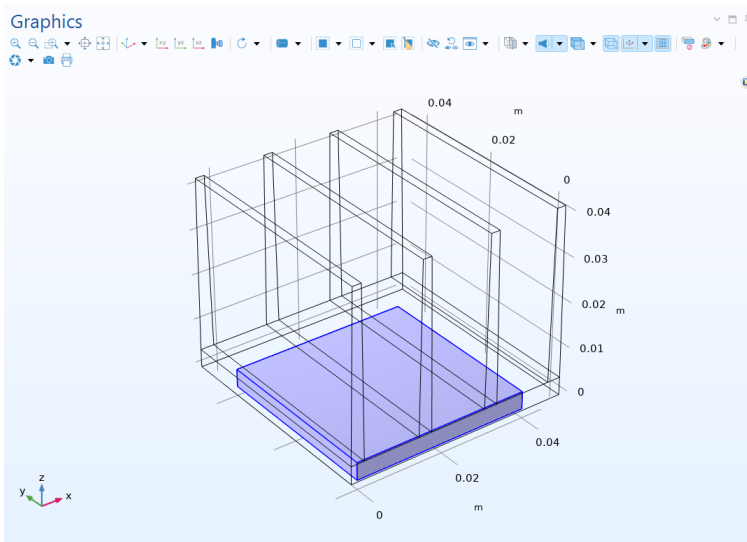



Note: There are many ways to select geometric entities. To select a domain that is underneath or inside another domain, first position the mouse over the desired domain. This will highlight the outer domain. You can select the desired domain from this position using the scroll wheel of a mouse or the arrow keys and then clicking when the correct domain is highlighted. This adds the domain to the Selection list. For more information about selecting geometric entities in the Graphics window, see the *COMSOL Multiphysics Reference Manual*.

In order to easily reuse the selection of the domain corresponding to the chip, create a dedicated selection for it.

- 5 In the Geometric Entity Selection section, click Create Selection .
- 6 In the Create Selection dialog, type Chip in the Selection name text field and click OK.



Definition

- 1 In the Physics toolbar click Ambient Properties  under Shared Properties  to create a node that defines the ambient properties. While default settings are kept for this model it is possible to modify user defined settings or to import

ambient properties from existing climate databases. The Ambient Properties node defines ambient quantities like temperature, pressure, or relative humidity that can be used in the model features, in particular to define boundary condition settings.

Heat Transfer in Solids (ht)

Heat Source 1

- In the Physics toolbar click Domains  and choose Heat Source .

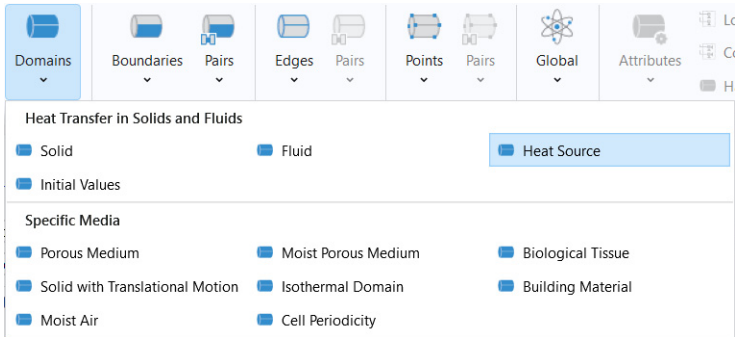

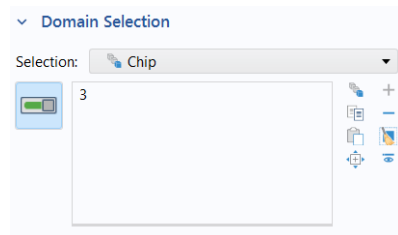

- In the Settings window for Heat Source, locate the Domain Selection section.
- From the Selection list, choose Chip. You can verify that domain 3 is then selected.

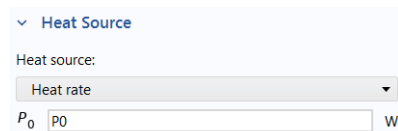

- Locate the Heat Source section, in the Heat Source list choose Heat rate.
- In the P_0 text field, type P_0 . P_0 is one of the parameters imported from a text file previously.



Heat Flux 1

- 1 In the Physics toolbar click Boundaries  and choose Heat Flux .

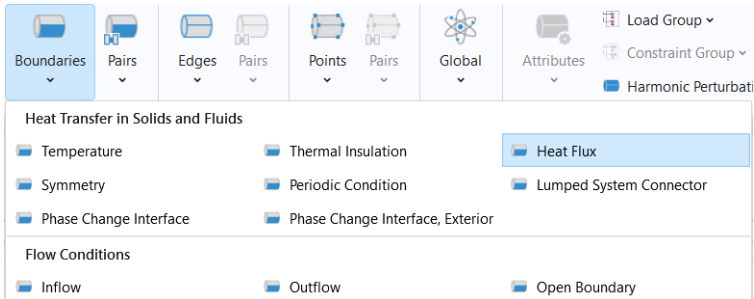

- 2 In the Settings window for Heat Flux, locate the Boundary Selection section.
- 3 From the Selection list, choose Exterior boundaries without heat sink base (Heat Sink - Straight Fins 1).

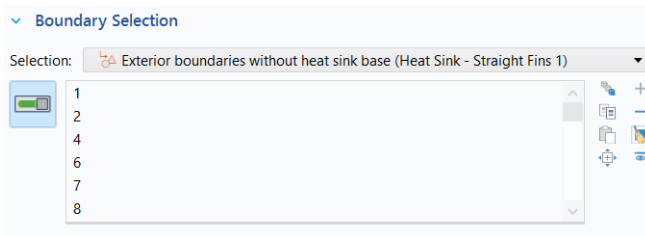

- 4 Locate the Heat Flux section.
- 5 In the Flux type list, choose Convective heat flux.
First enter the heat transfer coefficient defined from a parameter.

- 6 In the h text field, type h_0 .
Then the external temperature is set to the ambient temperature defined in the heat transfer interface (default value is 293.15 K).

- 7 From the T_{ext} list, choose Ambient temperature (ampr1).

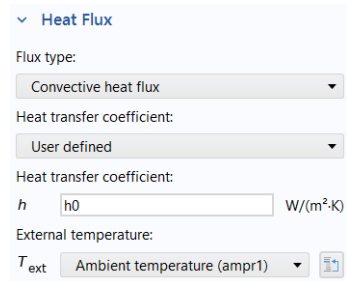

Study I

Step 1: Stationary

1 In the Home toolbar click Compute .

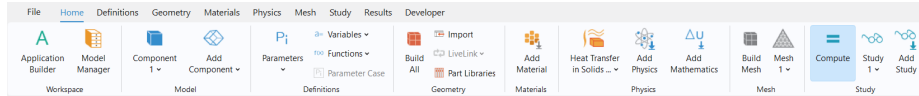

The computation takes a few seconds.

Results

The automatically generated default plot shows the temperature in the domain. Modify this plot to display the temperature at the interface between the chip and the heat sink.

In order to display the temperature plots under the Results branch in °C, you can add a Preferred Units node.

1 In the Results toolbar, click Configurations  and choose Preferred Units .



2 Click Add Physical Quantity  and, in the Physical Quantity dialog, select General > Temperature (K) in the tree. Click OK.

3 Choose °C as the Preferred unit for the Temperature.

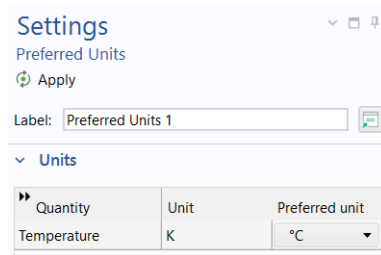

4 Click Apply .



Selection 1



- 1 Right-click Volume 1  and choose Selection .
- 2 In the Selection list, choose Chip.

Volume 2

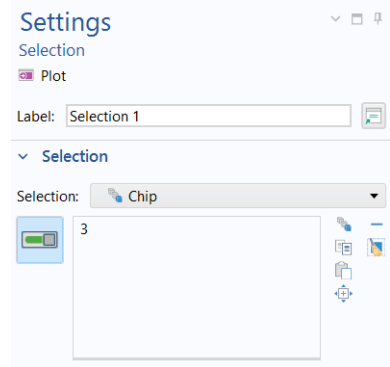
- 1 Right-click Volume 1  and choose Duplicate .
- 2 In the Settings window for Volume 2, expand the Title section and set the Title type to None.
- 3 Expand the Inherit Style section and from the Plot list select Volume 1.





Selection 1

- 1 Expand the Volume 2  node and click Selection 1 .
- 2 In the Selection list, choose All (Heat Sink - Straights Fins 1)

Filter 1

Add a filter to display only half of the heat sink and enable seeing the chip surface.

- 1 Right-click Volume 2  and choose Filter .
- 2 In the Settings window for Filter, locate the Element Selection section
- 3 In the Logical expression for inclusion text field, type $x > 0.02$.

4 In the Temperature (ht) toolbar, click the Plot  button.

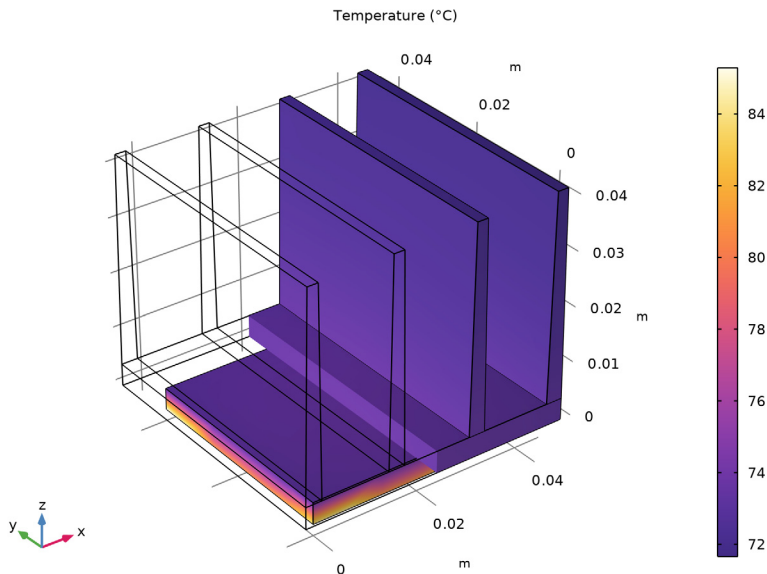



Compare with temperature plot above.

Heat Transfer in Solids (ht)

Now update the model to evaluate the effect of the thermal contact between the chip and the heat sink. First assume a poor thermal contact due to a thin film of air between the chip and the heat sink.

Thermal Contact I

- 1 In the Physics toolbar, click Boundaries  and choose Thermal Contact .

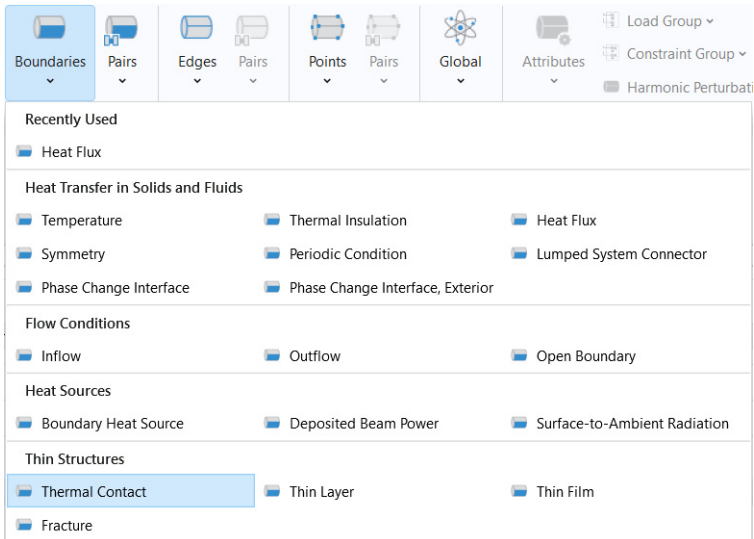

- 2 Select the interface between the electronics packaging and the heat sink, boundary 15. Verify that it appears in the Settings window for Thermal Contact in the Boundary Selection section.

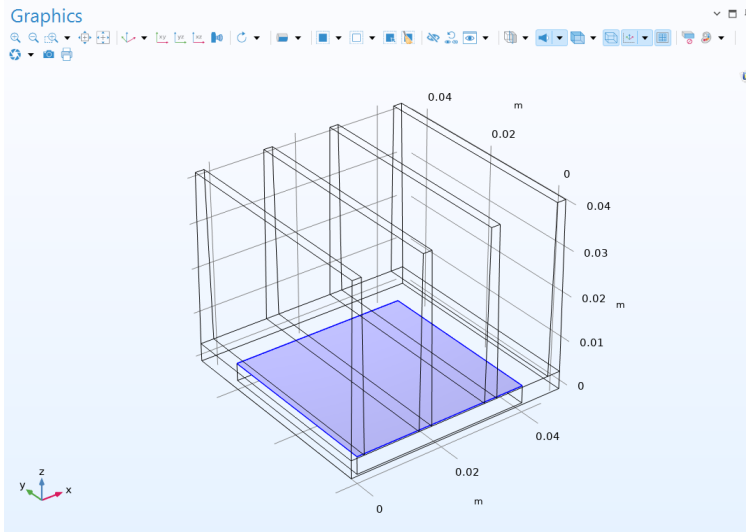

To facilitate the selection of this boundary in the following steps, create a dedicated selection for it.

- 3 Locate the Selection section; click Create Selection ; and, in the Create Selection dialog, type Chip/Heat Sink Interface in the Selection name text field.
- 4 Click OK.
- 5 Locate the Thermal Contact section and from the Contact model list, choose Equivalent thin resistive layer.
- 6 In the Specify list, select Layer thermal conductivity and thickness.
- 7 Keep the default value, From material, for the Layer thermal conductivity and in the d_s text field, enter 50[um].

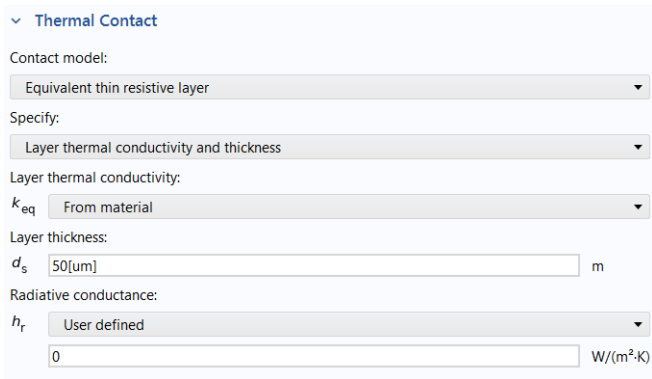

▼ Thermal Contact

Contact model:
Equivalent thin resistive layer

Specify:
Layer thermal conductivity and thickness

Layer thermal conductivity:
 k_{eq} From material





Layer thickness:
 d_s 50[um] m

Radiative conductance:
 h_r User defined
0 W/(m².K)

Materials

Define the material (air) present at the interface between the chip and the heat sink.

Air

- 1 In the Home toolbar click Add Material .
- 2 In the Add Material window under Built-In, click Air .
- 3 Click Add to Component .
- 4 Click Add Material  In the Home toolbar to close the material tab.
- 5 In the Model Builder window, select Component 1 (comp1) > Materials > Air (mat3).

- 6 In the Geometric Entity Selection section, choose Boundary from the Geometric entity level list.
- 7 From the Selection list, choose Chip/Heat Sink Interface.
- 8 In the Home toolbar, click Compute .

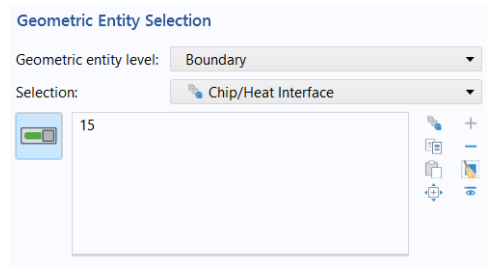

Results



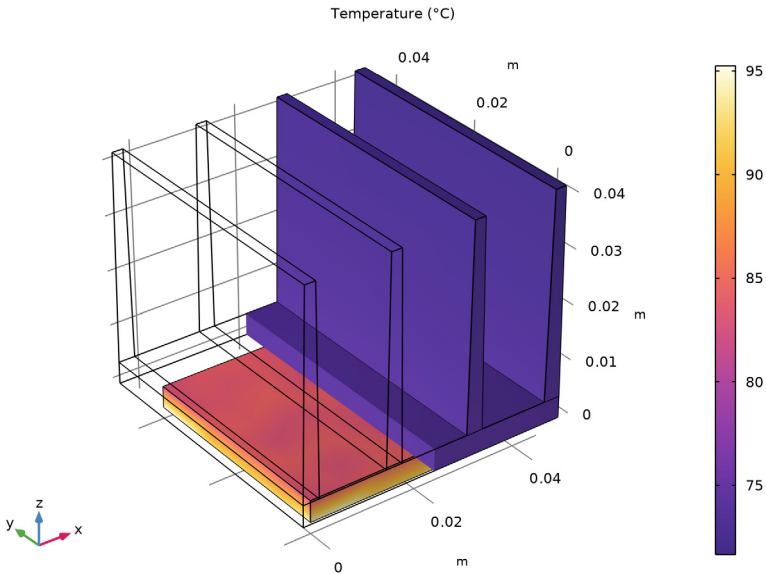

The temperature plot is updated after the computation. Note that the presence of the thin layer of air between the chip and the heat sink induced about 10°C increase of the maximum temperature.



Materials

Now assume that thermal grease is used to avoid an air layer at the interface between the chip and the heat sink. Update the model in order to check how the cooling is improved by this change.

Thermal Grease

- 1 In the Home toolbar click Add Material .
- 2 In the Add Material window under Built-In, click Thermal grease .
- 1 Click Add to Component .
- 2 Click again Add Material  In the Home toolbar to close the material tab.
- 3 In the Model Builder window, select Component 1 (comp1) > Materials > Thermal grease (mat4).
- 4 In the Geometric Entity Selection section, choose Boundary from the Geometric entity level list.
- 5 From the Selection list, choose Chip/Heat Sink Interface.
The red triangle on the Air material icon indicates that it is overridden by the Thermal grease material.
- 6 In the Home toolbar, click Compute .

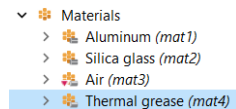

Results

The temperature plot is updated and shows the temperature distribution when thermal grease is used.

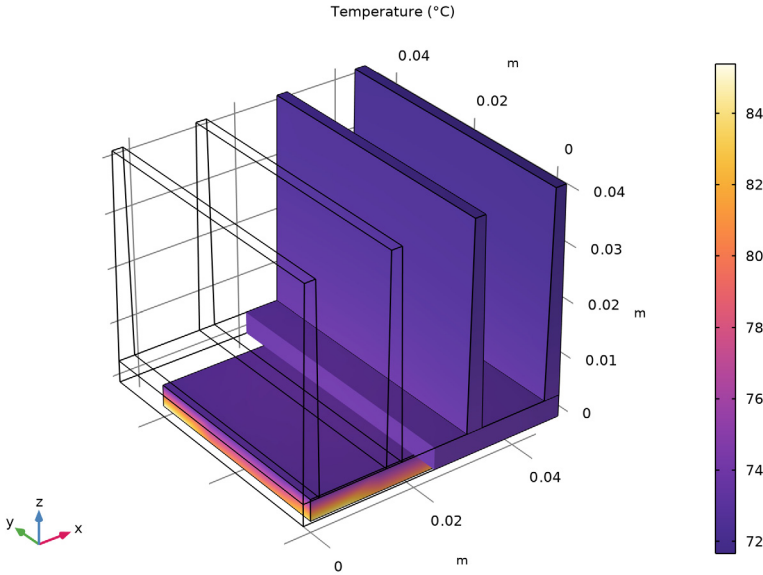



At this point, we can evaluate the effect of the quality of the thermal contact. In the first computation, the thermal contact was assumed to be ideal and the maximum temperature was around 85°C. When accounting for a 50- μm -wide air layer, the maximum temperature was close to 95°C. Using thermal grease to enhance the thermal contact seems efficient here as the maximum temperature is only slightly higher than the initial case of ideal thermal contact.

Geometry I

In the first part, we have been using a convective cooling boundary condition to account for the airflow cooling. While there are a number of geometrical configurations for which the heat transfer coefficient is known with very good accuracy, that is not the case for this particular heat sink geometry.

Modify the model to include the air channel in the geometry and to compute the air velocity. Then, you can accurately model the flow cooling without relying on any approximation of the heat transfer coefficient.

Block 2 (blk2)

- 1 In the Geometry toolbar, click Block .
- 2 In the Settings window for Block, locate the Size and Shape section.
- 3 In the Width text field, type W_{channel} .
- 4 In the Depth text field, type D_{channel} .
- 5 In the Height text field, type H_{channel} .
- 6 Locate the Position section and type $-(W_{\text{channel}}-40[\text{mm}])/2$ in the x text field.
- 7 In the y text field, type $-80[\text{mm}]$.
- 8 In the Geometry toolbar, click Build All .
- 9 In the Graphics toolbar, click the Zoom Extents button .

Size and Shape

Width: m

Depth: m

Height: m

Position

Base:

Position type:

x: m

y: m

z: m

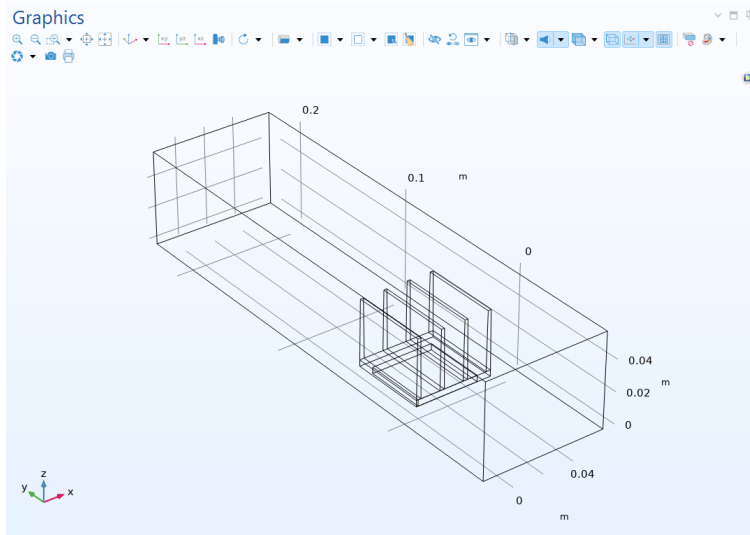

Materials

Define the material properties in the newly created channel domain.

Air I (mat5)

- 1 In the Model Builder window, right-click Air (mat3) under Component 1 (comp1) > Materials and choose Duplicate .

This creates a new instance of the Air material that will be applied to the domain selection corresponding to the channel.

- 2 In the Settings window for Material, locate the Geometric Entity Selection section and select Domain in the Geometric entity level list.

- 3 Select Domain 1 only.

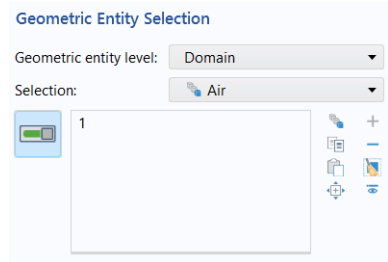

- 4 Click Create Selection  and, in the Create Selection dialog, type Air in the Selection name text field. Click OK.



Laminar Flow

In the Home toolbar, click the Add Physics button .



Add Physics

- 1 In the Add Physics window select Fluid Flow > Single-Phase Flow > Laminar Flow (spf).
- 2 Click Add to Component 1 .
- 3 Click Add Physics button  again to close the Add Physics panel.

Laminar Flow (spf)

- 1 In the Model Builder window, under Component 1 (comp1) click Laminar Flow (spf) .
Specify that the flow interface is active only in the air channel.
- 2 In the Settings window for Laminar Flow, locate the Domain Selection section.
- 3 From the Selection list, choose Air.

Inlet 1

- 1 In the Physics toolbar click Boundaries  and choose Inlet .
- 2 Select Boundary 2, then click Create Selection .

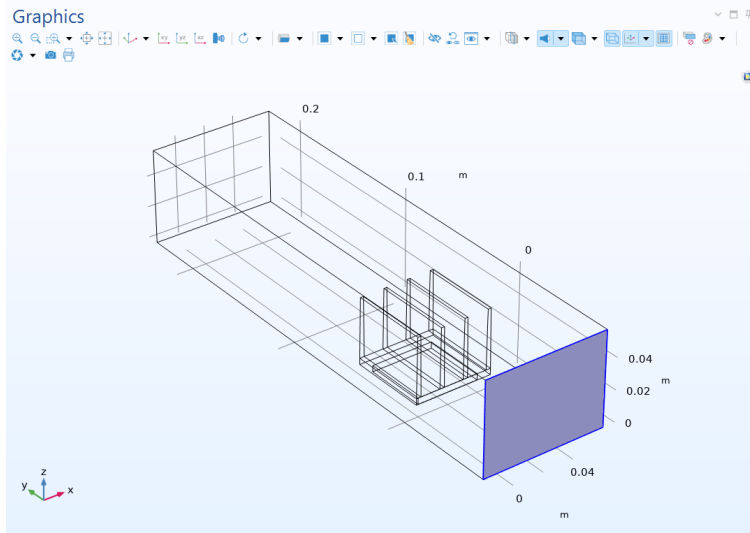

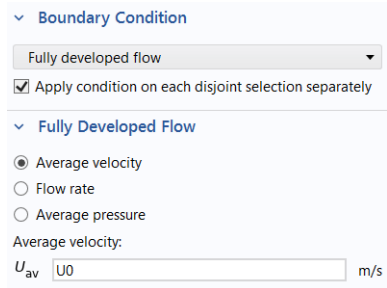

- 3 In the Create Selection dialog, type `Inlet` in the Selection name text field.
Click OK.

- 4 In the Settings window for Inlet, locate the Boundary Condition section.
- 5 Select Fully developed flow.
- 6 In the Fully Developed Flow section, in the U_{av} text field, type $U0$.



Outlet 1

- 1 In the Physics toolbar click Boundaries  and choose Outlet .
- 2 Select Boundary 5, then click Create Selection .

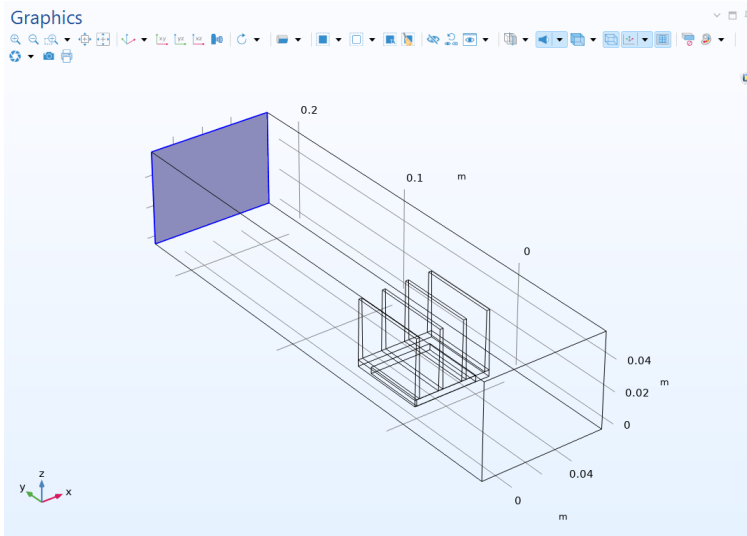

- 3 In the Create Selection dialog, type `Outlet` in the Selection name text field. Click OK.



Heat Transfer in Solids and Fluids (ht)

The boundaries where the heat flux condition was applied are no longer exterior boundaries, so the heat flux condition cannot be applied. Instead, a continuity condition is applied by default between the solid and the fluid domains.



Fluid 1

- 1 In the Model Builder windows, under Component 1 > Heat Transfer in Solids and Fluids select Fluid 1 node.
- 2 In the Settings window for Fluid, locate the Domain Selection section.
- 3 From the Selection list, choose Air.

Inflow 1



- 1 In the Physics toolbar click Boundaries  and choose Inflow .
- 2 In the Settings window for Inflow, locate the Boundary Selection section.
- 3 From the Selection list, choose Inlet.
- 4 In the Upstream Properties section, from the T_{ustr} list, select Ambient temperature (ampr1).

Outflow 1

- 1 In the Physics toolbar click Boundaries  and choose Outflow .
- 2 In the Settings window for Outflow, locate the Boundary Selection section.
- 3 From the Selection list, choose Outlet.

Multiphysics

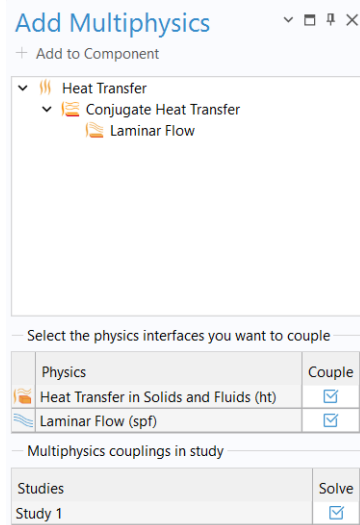

Now add the Nonisothermal Flow multiphysics feature to couple the Heat Transfer in Solids and Fluids and Laminar Flow interfaces. By doing this, you ensure in particular that the velocity field computed by the Laminar Flow interface is used by the Fluid 1 feature in the Heat Transfer interface. In addition, the temperature dependence of the material properties in the flow interface is then defined from the temperature field computed by the Heat Transfer interface.

- 1 In the Model Builder window, right-click on Component 1 (comp1) and select Add Multiphysics .
- 2 Go to the Add Multiphysics window. In the tree, select Heat Transfer > Conjugate Heat Transfer > Laminar Flow.
- 3 Click Add to Component . Close the Add Multiphysics window.



Mesh 1

As this tutorial is intended to explore the heat transfer modeling capabilities, define a coarse mesh to speed up the computation. Note however that for accurate results, a finer mesh is needed.

- 1 In the Model Builder window, select Mesh 1  and, in the Physics-Controlled Mesh section, choose Extremely coarse in the Element size list.
- 2 In the table, clear the Use checkbox for Geometric Analysis Detail Size.
- 3 In the Home toolbar, click Compute .

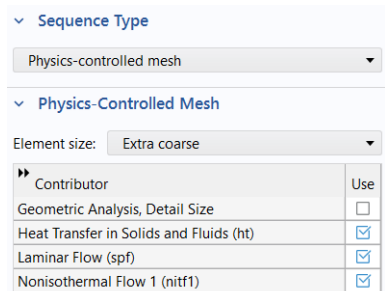



Results

The computation for this model takes about 30 seconds and about 3 GB of memory. The longer computational time is due to the extra degrees of freedom corresponding to the velocity, pressure, and temperature in the air domain.



Add a predefined plot as a result template showing temperature and velocity field and hide some walls from the display to visualize the temperature in the heat sink and on the channel walls together with the flow structure.

Temperature and flow in the channel

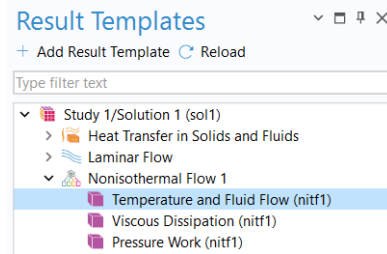
- 1 In the Home toolbar, click  Result Templates.
- 2 Go to the Result Templates window and select Study 1/Solution 1 (sol1) > Nonisothermal Flow 1 > Temperature and Fluid Flow (nitf1).
- 3 Click Add Result Template  and close the Result Templates window.



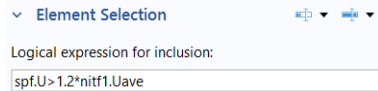

Filter 1

- 1 In the Temperature and Fluid Flow (nitf1) 3D Plot Group, expand the Fluid Flow  and select Filter 1 .
- 2 Locate the Element Selection section and, in the associated text field, type $spf.U > 1.2 * nitf1.U_{ave}$.



Geometry 1

- 1 In the Model Builder window, under Component 1 (comp1) click Geometry 1 .
- 2 In the Graphics toolbar, click the Click and Hide button . Then, click the Select Boundaries button .

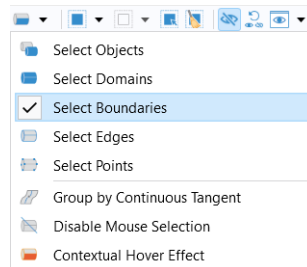

- 3 In the Graphics window, select the boundaries corresponding to the inlet, the outlet, the upper boundary of the channel and the left boundary.

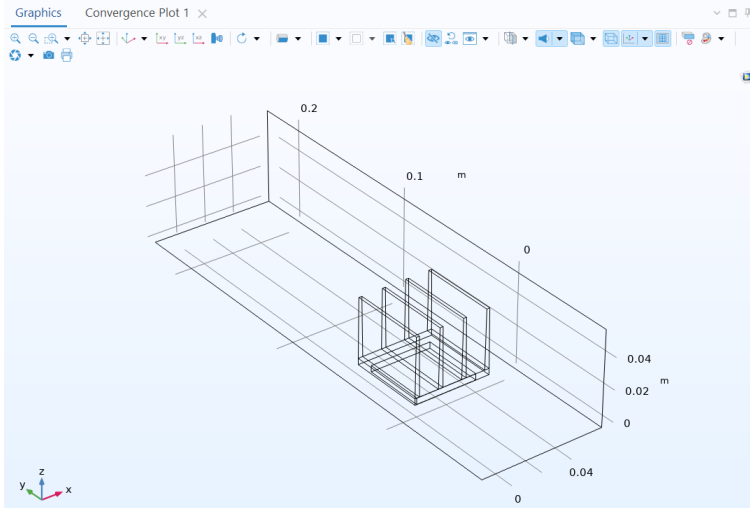

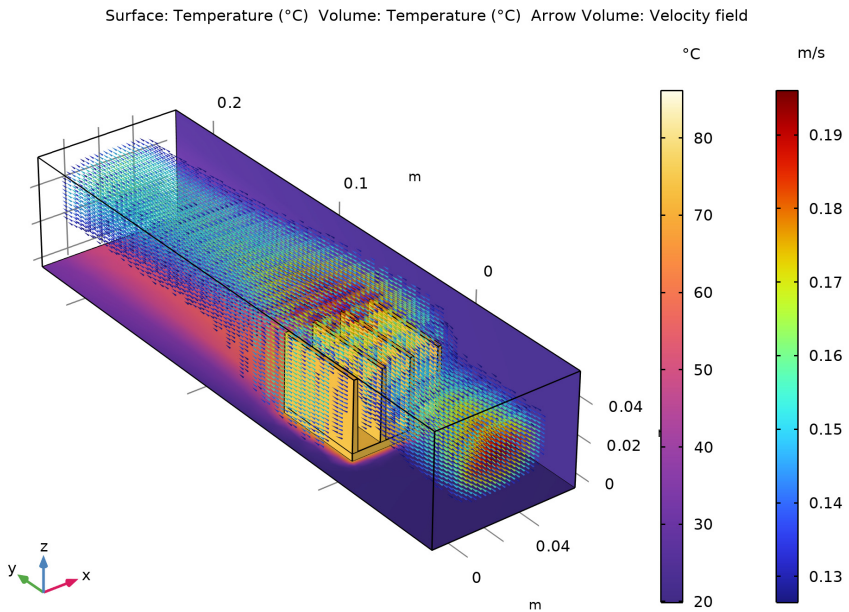

- 4 In the Model Builder window, select the Temperature and Fluid Flow (nitfl) node to display the temperature field as well as the fluid flow.



Duplicate this plot and keep only temperature subnodes to focus on the temperature distribution.

Temperature of the channel walls and heat sink

- 1 In the Model Builder window, right-click Temperature and Fluid Flow (nitf1) and choose Duplicate .
- 2 In the Settings window for 3D Plot Group, type Temperature of the channel walls and heat sink in the Label text field.
- 3 Expand Temperature and Fluid Flow (nitf1), right-click Fluid Flow  and choose Delete . Click Delete to confirm.
- 4 Select the Temperature and Fluid Flow (nitf1) node. In the Settings window for 3D Plot Group, locate the Color Legend section and clear the Show units checkbox.

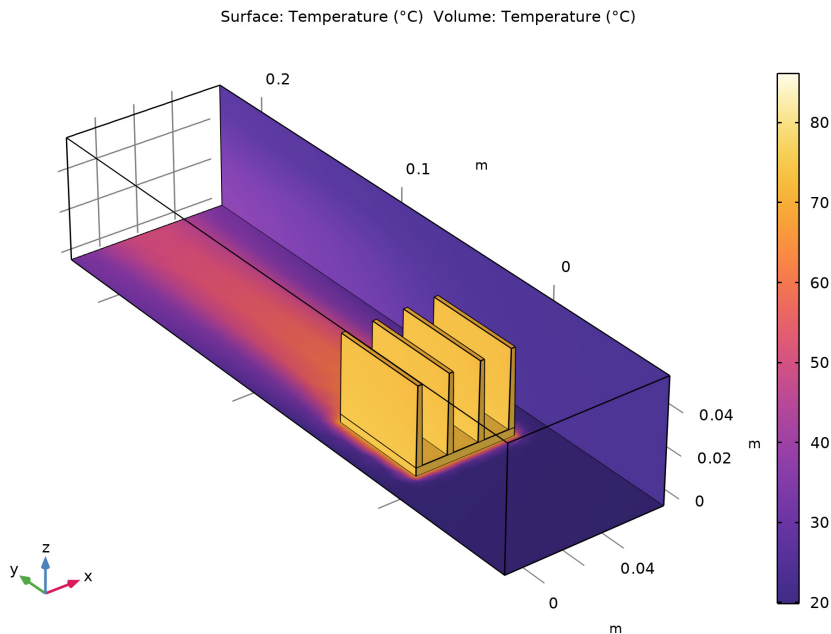



Adding Surface-to-Surface Radiation Effects

Now modify the model to include surface-to-surface radiation effects. First, add the surface-to-surface radiation physics interface to the model. Then, study the effects of surface-to-surface radiation between the heat sink and the channel walls.

Surface-to-Surface Radiation (rad)

In the Home toolbar, click the Add Physics button .

Add Physics

- 1 In the Add Physics window select Heat Transfer > Radiation > Surface-to-Surface Radiation (rad). .
- 2 Click Add to Component 1 .
- 3 Click Add Physics button  again to close the Add Physics panel.

Surface-to-Surface Radiation (rad)

- 1 In the Model Builder window, under Component 1 (comp1), click Surface-to-Surface Radiation (rad) .

Specify that the radiation interface is active only on the heat sink and channel walls.



- 2 In the Settings window for Surface-to-Surface Radiation, locate the Boundary Selection section.
- 3 From the Selection list, choose Exterior boundaries without heat sink base (Heat Sink - Straight Fins 1).
- 4 To add the channel walls, click the Paste Selection button  and type 1 3 4 44 (note that boundaries 1 and 4 have been hidden previously and are not visible in the graphics window).

The interface selection now contains boundaries 1, 3, 4, 6, 7, 9, 11–16, 22, 24–29, 31–35, 37, and 39–44.

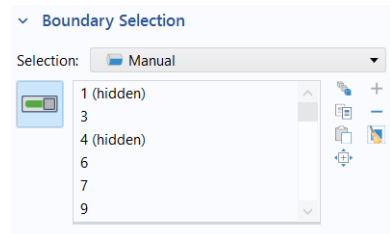
By default the radiation direction is controlled by the opacity of the domains. The solid parts are automatically defined as opaque while the fluid parts are transparent. You can change this setting by using the Opacity feature in the Surface-to-surface Radiation interface. When the Diffuse Surface boundary condition defines the Emitted radiation direction as opacity controlled (the default setting), the selected boundaries should be located between an opaque and a transparent domain. The exterior is defined as transparent by default. Change the default setting to make the exterior opaque and have the radiation direction automatically defined on the channel walls.



Opacity 1

- 1 In the Physics toolbar click Domains  and choose Opacity .
- 2 In the Settings window for Opacity, locate the Domain Selection section.
- 3 From the Selection list, choose All voids which corresponds to the geometry exterior.

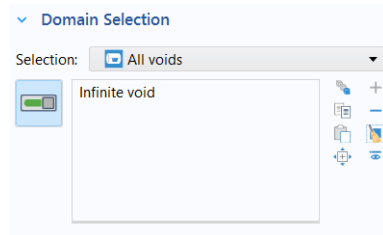

Heat Transfer with Surface-to-Surface Radiation

- 1 In the Model Builder window, right-click on Component 1 (comp1) and select Add Multiphysics .
- 2 Go to the Add Multiphysics window.
- 3 Modify the physics interface selection so that only Heat Transfer in Solids and Fluids (ht) and Surface-to-surface Radiation (rad) interfaces are selected.
- 4 In the tree, select Heat Transfer > Radiation > Heat Transfer with Surface-to-Surface Radiation.
- 5 Click Add to Component in the window toolbar and close the Add Multiphysics window.

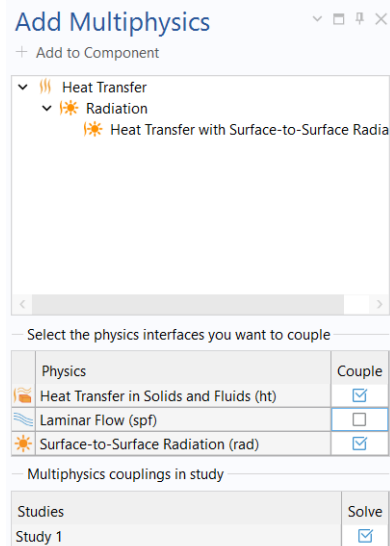

Materials

Heat Sink Walls

- 1 In the Material toolbar, click Blank Material .
- 2 In the Settings window for Material, type Heat sink walls in the Label text field.
- 3 Locate the Geometric Entity Selection section. From the Geometric entity level list and choose Boundary.

- From the Selection list, choose Exterior boundaries without heat sink base (Heat Sink - Straight Fins 1).

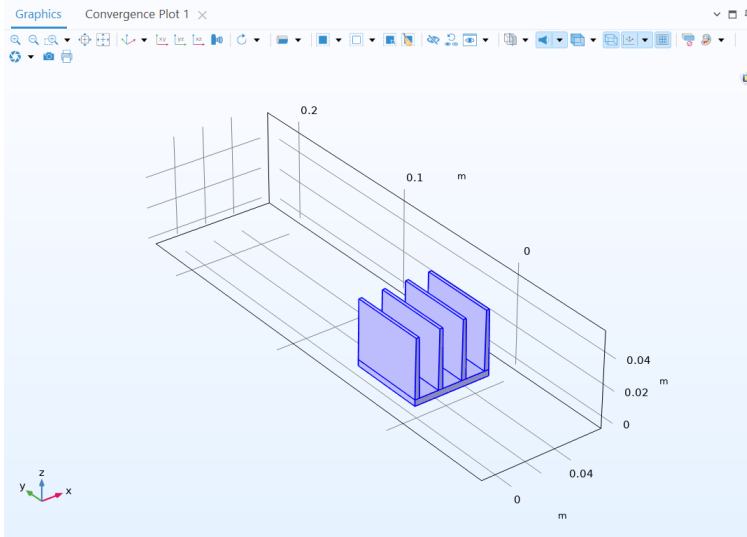

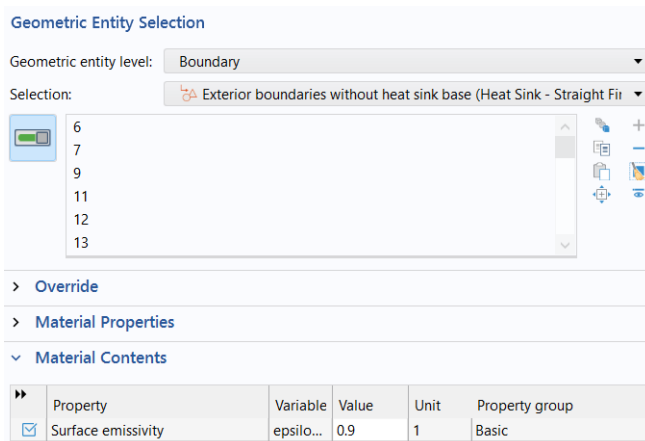

- Locate the Material Contents section. In the table, define the Surface Emissivity equal to 0.9.





Channel Walls

- In the Material toolbar click Blank Material .
- In the Settings window for Material, type Channel walls in the Label text field.

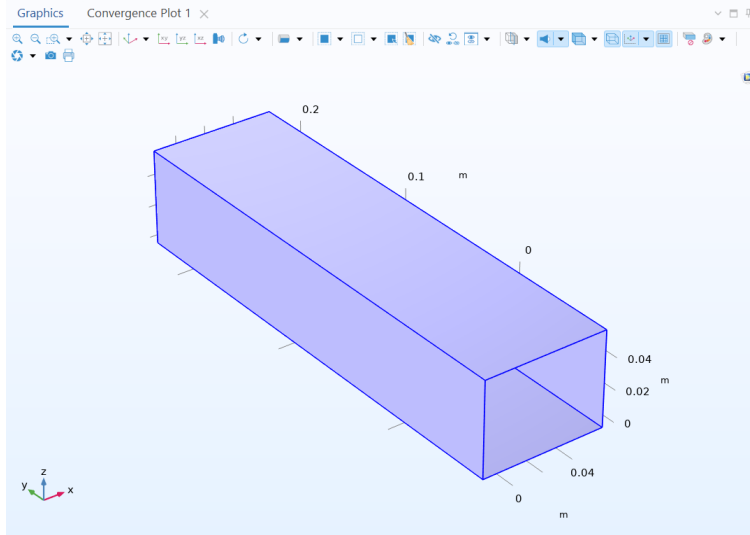
- 3 Locate the Geometric Entity Selection section. From the Geometric entity level list, choose Boundary.
- 4 In the Graphics toolbar, click  next to the View Unhidden  button, then choose View all .
- 5 Select Boundaries 1, 3, 4, and 44, which correspond to the channel walls.



- 6 In the Graphics toolbar, click  next to the View all  button and select View Unhidden .
- 7 In the table that defines the Surface emissivity enter 0.85.

▼ Material Contents

Property	Variable	Value	Unit	Property group
<input checked="" type="checkbox"/> Surface emissivity	epsilo...	0.85	1	Basic

Study 2

In order to keep the previous solution and to be able to compare it with this version of the model, rename the first study for clarity and add a second stationary study.





- 1 In the Model Builder window, select Study 1 node and, in the Settings window, rename it Study 1 Without Radiation.

- 2 In the Model Builder window, under Study 1 Without Radiation click Step 1: Stationary.
- 3 In the Settings window for Stationary, locate the Physics and Variables Selection section.
- 4 In the table, clear the Solve for checkbox for Surface-to-Surface Radiation (rad).
- 5 In the table, clear the Solve for checkbox for Heat Transfer with Surface-to-Surface Radiation 1 (htrad1).

Physics and Variables Selection

Modify model configuration for study step

Node	Solve for	Equation form
Component 1 (comp1)	<input checked="" type="checkbox"/>	Automatic
Heat Transfer in Solids and Fluids (ht)	<input checked="" type="checkbox"/>	Automatic (Stationary)
Laminar Flow (spf)	<input checked="" type="checkbox"/>	Automatic (Stationary)
Surface-to-Surface Radiation (rad)	<input type="checkbox"/>	Automatic (Stationary)
Multiphysics		
Nonisothermal Flow 1 (nitf1)	<input checked="" type="checkbox"/>	Automatic (Stationary)
Heat Transfer with Surface-to-Surfac...	<input type="checkbox"/>	Automatic (Stationary)

- 6 In the Home toolbar, click Add Study .
- 7 In the Add Study window, select General Studies > Stationary .
- 8 Click Add Study .
- 9 Click Add Study button  again to close the Add Study panel.
- 10 Select Study 2 node and, in the Settings window, rename it Study 2 With Radiation.
- 11 In the Home toolbar, click Compute .

Results

Five default plots are generated automatically. The first four represent respectively the temperature field in both the solid and fluid domain, the velocity magnitude of the fluid flow, the pressure profile on the boundaries and the surface radiosity on the boundaries. The last default plot is identical to the predefined plot previously added and shows the temperature in the heat sink and on the channel walls together with the flow structure.

- 1 In the Model Builder window, right-click Temperature and Fluid Flow (nitf1) 1 and choose Duplicate .
- 2 In the Settings window for 3D Plot Group, type Temperature of the channel walls and heat sink, with radiation in the Label text field.
- 3 Locate the Color Legend section and clear the Show units checkbox.

- 4 In the Model Builder window, expand the Temperature of the channel walls and heat sink, with radiation node.
- 5 Right click Fluid Flow and choose Delete  .

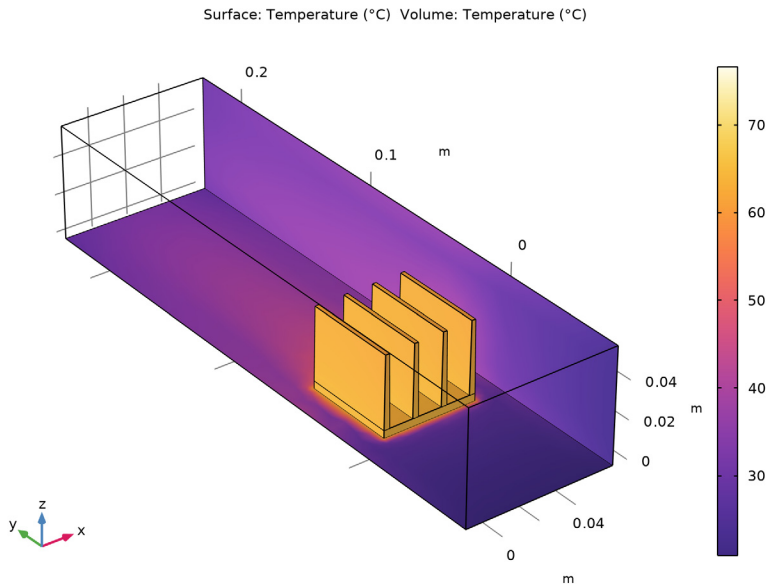

By comparing this plot with the previous temperature plot we observe that the heat transfer by radiation induces a significant cooling and that the maximum temperature is about 10°C lower when thermal radiation is accounted for.

In order to visualize the temperature on each side of the thermal contact, follow the next steps.

Contact Temperature (ht)

- 1 In the Home toolbar, click  Result Templates.
- 2 Go to the Result Templates window and select Study 2 With Radiation/ Solution 2 (sol2) > Heat Transfer in Solids and Fluids > Contact Temperature (ht).

3 Click Add Plot + and close the Result Templates window.

