

INTRODUCTION TO  
Fuel Cell &  
Electrolyzer Module

# Introduction to the Fuel Cell & Electrolyzer Module

© 1998–2025 COMSOL

Protected by patents listed on [www.comsol.com/patents](http://www.comsol.com/patents), and U.S. Patents 7,519,518; 7,596,474; 7,623,991; 8,457,932; 8,954,302; 9,098,106; 9,146,652; 9,323,503; 9,372,673; 9,454,625; 10,019,544; 10,650,177; and 10,776,541. Patents pending.

This Documentation and the Programs described herein are furnished under the COMSOL Software License Agreement ([www.comsol.com/comsol-license-agreement](http://www.comsol.com/comsol-license-agreement)) and may be used or copied only under the terms of the license agreement.

COMSOL, the COMSOL logo, COMSOL Multiphysics, COMSOL Desktop, COMSOL Compiler, COMSOL Server, and LiveLink are either registered trademarks or trademarks of COMSOL AB. All other trademarks are the property of their respective owners, and COMSOL AB and its subsidiaries and products are not affiliated with, endorsed by, sponsored by, or supported by those trademark owners. For a list of such trademark owners, see [www.comsol.com/trademarks](http://www.comsol.com/trademarks).

Version: COMSOL 6.4

## Contact Information

Visit the Contact COMSOL page at [www.comsol.com/contact](http://www.comsol.com/contact) to submit general inquiries or search for an address and phone number. You can also visit the Worldwide Sales Offices page at [www.comsol.com/contact/offices](http://www.comsol.com/contact/offices) for address and contact information.

If you need to contact Support, an online request form is located on the COMSOL Access page at [www.comsol.com/support/case](http://www.comsol.com/support/case). Useful links:

- Support Center: [www.comsol.com/support](http://www.comsol.com/support)
- Product Download: [www.comsol.com/product-download](http://www.comsol.com/product-download)
- Product Updates: [www.comsol.com/product-update](http://www.comsol.com/product-update)
- COMSOL Blog: [www.comsol.com/blogs](http://www.comsol.com/blogs)
- Discussion Forum: [www.comsol.com/forum](http://www.comsol.com/forum)
- Events: [www.comsol.com/events](http://www.comsol.com/events)
- COMSOL Video Gallery: [www.comsol.com/videos](http://www.comsol.com/videos)
- Support Knowledge Base: [www.comsol.com/support/knowledgebase](http://www.comsol.com/support/knowledgebase)
- Learning Center: [www.comsol.com/support/learning-center](http://www.comsol.com/support/learning-center)

Part number: CM025102

# Contents

---

Introduction .....	5
Fuel Cell and Electrolyzer Modeling .....	6
The Fuel Cell & Electrolyzer Module Physics Interfaces .....	9
Physics Interface Guide by Space Dimension and Study Type ...	11
Model Definition .....	16
Results and Discussion .....	19



## Introduction

---

The Fuel Cell & Electrolyzer Module simulates the fundamental processes in the electrodes and electrolytes of fuel cells and electrolyzers. These simulations can involve the transport of charged and neutral species, current conduction, fluid flow, heat transfer, and electrochemical reactions in porous electrodes.

You can use this module to investigate the performance of fuel and electrolyzer cells for different electrode configurations, membranes, separators and diaphragms, current collectors and feeders, materials, and chemistry. The description of the involved processes and phenomena is rather detailed, and you can therefore apply different hypotheses to gain an understanding of the investigated systems. You can study the influence of different electrocatalysts, pore distribution, electrolyte composition, and other fundamental parameters directly in the physics interfaces.

You can also couple the electrochemistry to other physics such as heat transfer, fluid flow, structural mechanics, and chemical species transport in order to study phenomena like thermal effects and stress-strain relationships.

# Fuel Cell and Electrolyzer Modeling

This module includes functionality to model fuel cell and electrolyzer unit cells that consist of:

- Current collectors and current feeders
- Gas channels usually formed by grooves in the current collectors and feeders
- Porous gas diffusion electrodes (GDEs)
- Porous gas diffusion layers (GDLs)
- The electrolyte that separates the anode and cathode, typically residing in a separator/diaphragm or a membrane.

Figure 1 shows a schematic drawing of a fuel cell unit cell and the structure of one of the GDEs. It represents a fuel cell unit cell and a magnified section of the cathode GDE and its contact with the electrolyte.

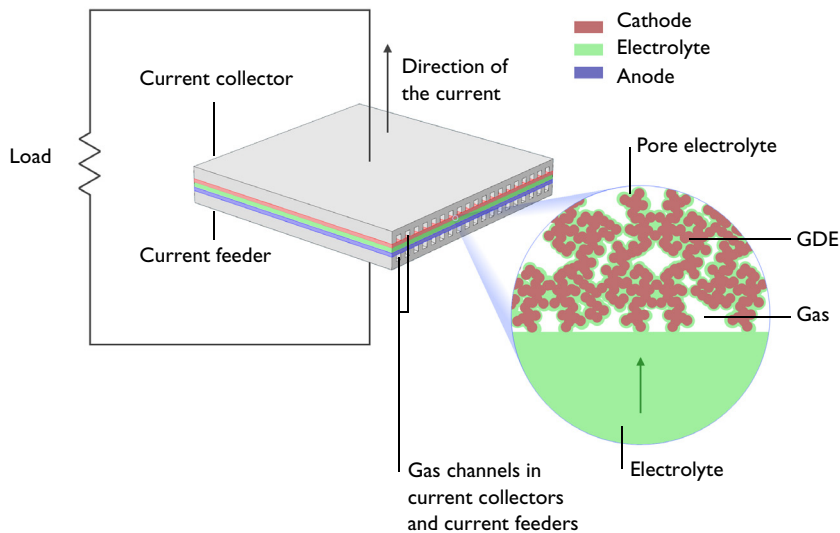

Figure 1: Fuel cell unit cell and a magnified section of the cathode GDE and its contact with the electrolyte.

Oxygen and hydrogen are supplied to the cell through the gas channels in the current collector and current feeder, respectively. The current collector and the current feeder are made of electrically conductive materials and are equipped with grooves that form the gas channels. These grooves are open channels with the open side facing the surface of the GDEs.

The current collectors and feeders also conduct the current to the wires connected to the load. They can also supply cooling required during operation and heating required during startup of the cell.

The GDE magnified in [Figure 1](#) is an oxygen-reducing cathode in a fuel cell with an acidic polymer electrolyte (ionomer), for example, the proton exchange membrane fuel cell (PEMFC). In the PEMFC, the active GDE is confined to a thin active layer supported by a pure gas diffusion layer (GDL).

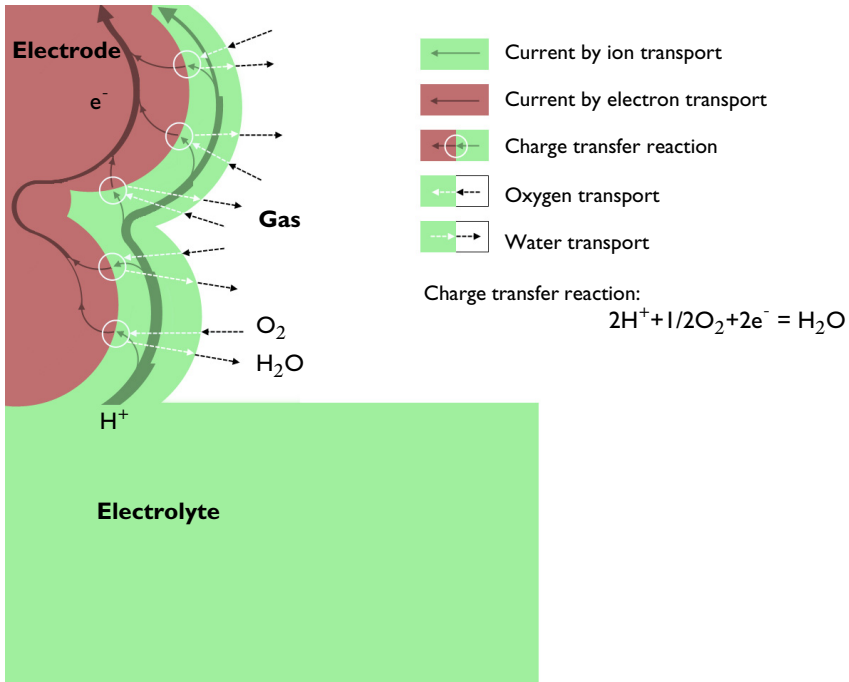

Figure 2: Transport of oxygen, water, protons, and electrons to and from the reaction site in an oxygen reducing GDE.

[Figure 2](#) shows the principle of the oxygen reduction process in the electrode. From the bulk electrolyte, current enters the electrolyte contained in the GDE (also called pore electrolyte) as protons and is transferred to electron current in the charge transfer reaction at the reaction sites. These reaction sites are situated at the interface between the electrocatalyst in the electrode material and the pore electrolyte.

[Figure 2](#) also describes the schematic path of the current in the electrode. The current in the pore electrolyte decreases as a function of the distance from the bulk

electrolyte when it is transferred to electron current in the electrode. The direction of the current in the electrode is opposite to that of the electrons, by definition.

The supply of oxygen takes place in conjunction with the charge transfer reaction and can be subject to mass transport resistance both in the gas phase and in the thin layer of pore electrolyte that covers the reaction site.

The water balance in the electrode is maintained through evaporation and transport through the gas pores.

The pore electrolyte has to form a continuous path from the bulk electrolyte, between the anode and the cathode, to the reaction site. Also, the electrode material and the gas pores must each form a continuous path to the reaction site or to the pore electrolyte covering the reaction site.

The processes described above include fluid flow, chemical species transport, heat transfer, current conduction in the collectors, feeders, electrodes, and electrolytes, and the electrochemical reactions. These are all coupled together and determine the characteristics of a unit cell.

Several important design parameters, for varied operation conditions, can be investigated by modeling these processes. Among these parameters are:

- Porosity, active surface area, and pore electrolyte content of the GDEs
- Geometry of the GDEs (active layer and GDL for the PEMFC) and electrolyte in relation to the gas channels, the current collectors, and feeders
- Geometry of the grooves that form the gas channels and dimensions of the current collectors and feeders

# The Fuel Cell & Electrolyzer Module Physics Interfaces

Figure 3 below shows the Fuel Cell & Electrolyzer Module interfaces, in the Electrochemistry branch, as displayed in the Model Wizard for a 3D model.









































- >  Chemical Species Transport
- ▼  Electrochemistry
  - ▼  Primary and Secondary Current Distribution
    -  Primary Current Distribution (cd)
    -  Secondary Current Distribution (cd)
  - ▼  Tertiary Current Distribution, Nernst-Planck
    -  Tertiary, Electroneutrality (tcd)
    -  Tertiary, Water-Based with Electroneutrality (tcd)
    -  Tertiary, Supporting Electrolyte (tcd)
    -  Tertiary, Poisson (tcd)
  -  Electroanalysis (tcd)
  -  Concentrated Electrolyte Transport (cet)
  -  Electrode, Shell (els)
  - ▼  Hydrogen Fuel Cells
    -  Proton Exchange Membrane (fc)
    -  Hydroxide Exchange Membrane (fc)
    -  Alkaline (fc)
    -  Molten Carbonate (fc)
    -  Solid Oxide (fc)
    -  Generic (fc)
  - ▼  Water Electrolyzers
    -  Proton Exchange Membrane (we)
    -  Hydroxide Exchange Membrane (we)
    -  Alkaline (we)
    -  Molten Carbonate (we)
    -  Solid Oxide (we)
    -  Generic (we)
- >  Fluid Flow
- >  Heat Transfer
- >  Structural Mechanics
- >  Mathematics





Figure 3: The 3D physics interfaces for the Fuel Cell & Electrolyzer Module, as shown in the Model Wizard, with the Electrochemistry branch fully expanded.

The Electrochemistry () interfaces are based on the conservation of current, charge, chemical species, and energy. The Hydrogen Fuel Cell () interfaces and Water Electrolyzer () interfaces are tailor-made interfaces for these cell types. These interfaces combine electrolyte and electrode charge transport with charge transfer reactions, and, optionally, gas phase mass transport and momentum transport by Darcy's law. Alternatively, the fluid flow in the gas channels and in the GDEs can be modeled by any of the Fluid Flow interfaces — such as Laminar

Flow () , Free and Porous Media Flow, Brinkman () and coupled to the hydrogen fuel cell or water electrolyzer interface.

For other types of fuel cells and electrolyzers (for instance a chlorine electrolyzer), the current transport by ions in the bulk electrolyte and in the pore electrolyte, the current transport by electrons, and the charge transfer reactions may be defined by the generic Primary Current Distribution () , Secondary Current Distribution () , and the Tertiary Current Distribution, Nernst–Planck () interfaces. The Primary Current Distribution interface neglects the variations in composition in the electrolyte and the activation losses for the charge transfer reactions. It should typically be used for electrolytes with fixed charge carriers or well-mixed electrolytes, and in the cases where the activation losses are substantially smaller than the conductivity losses. In the Secondary Current Distribution interface, the variations in composition in the electrolyte are also neglected, while the activation losses for the charge transfer reactions are taken into account. In the Tertiary Current Distribution, Nernst-Planck interface, also the contribution of diffusion to the transport of ions, and thus the bulk electrolyte contribution to the current in the electrolyte, is taken into account.

The Concentrated Electrolyte Transport interface () is a generic interface for defining electrolyte transport. The electrolyte transport model is based on concentrated solution theory and can be applied to any type of electrochemical cell for an arbitrary number of electrolyte species. In contrast to the Tertiary Current Distribution, Nernst-Planck interfaces, the Concentrated Electrolyte Transport interface does not assume the presence of a neutral solvent, or a supporting electrolyte, of constant concentration. The interface may for instance be used to model the electrolyte transport of a molten carbonate fuel cell or electrolyzer cell.

When modeling charge transport with a generic current distribution interface, the transport of gaseous species and other mass transport phenomena can be modeled using any of the Chemical Species Transport interfaces () , which all have nodes that couple the transport in the gas phase to the electrochemical reactions. The Chemical Species Transport interfaces are also coupled to the Fluid Flow interfaces () through the gas density, which is influenced by the gas composition. A convenient way of coupling chemical species transport to fluid flow is by using one of the Reacting Flow interfaces (Reacting Flow () or Reacting Flow in Porous Media () ), which contain predefined multiphysics couplings.











The Heat Transfer interfaces () handle the effects of Joule heating in the bulk electrolyte, in the pore electrolyte, and in the electrodes. They include the contribution to the thermal balance from the electrochemical reactions due to the activation overpotential and the net change of entropy.













The Electrode, Shell interface () models electric current conduction in the tangential direction on a boundary. The physics interface is suitable to use for thin electrodes where the potential variation in the normal direction to the electrode is

negligible. This assumption allows for the thin electrode domain to be replaced by a partial differential equation on the boundary. In this way the problem size can be reduced, and potential problems with mesh anisotropy in the thin layer can be avoided.















### ***Physics Interface Guide by Space Dimension and Study Type***

The table lists the physics interfaces available in the Fuel Cell & Electrolyzer Module in addition to those included with the COMSOL basic license.

PHYSICS INTERFACE	ICON	TAG	SPACE DIMENSION	AVAILABLE STUDY TYPE
 <b>Chemical Species Transport</b>				
Transport of Diluted Species		tds	all dimensions	stationary; time dependent
Transport of Concentrated Species		tcs	all dimensions	stationary; time dependent
Chemistry		chem	all dimensions	stationary; time dependent
Nernst–Planck–Poisson Equations		tds+es	all dimensions	stationary; time dependent; stationary source sweep; small-signal analysis, frequency domain
Electrophoretic Transport		el	all dimensions	stationary; stationary with initialization; time dependent; time dependent with initialization
Transport of Diluted Species in Porous Media		tds	all dimensions	stationary; time dependent
Transport of Concentrated Species in Porous Media		tcs	all dimensions	stationary; time dependent
Surface Reactions		sr	all dimensions	stationary (3D, 2D, and 2D axisymmetric models only); time dependent
Transport of Diluted Species in Fractures		dsf	3D, 2D, 2D axisymmetric	stationary; time dependent

PHYSICS INTERFACE	ICON	TAG	SPACE DIMENSION	AVAILABLE STUDY TYPE
 <b>Reacting Flow</b>				
Laminar Flow, Diluted Species		—	3D, 2D, 2D axisymmetric	stationary; time dependent
Laminar Flow, Concentrated Species		—	3D, 2D, 2D axisymmetric	stationary; time dependent
 <b>Reacting Flow in Porous Media</b>				
Transport of Diluted Species		—	3D, 2D, 2D axisymmetric	stationary; time dependent
Transport of Concentrated Species		—	3D, 2D, 2D axisymmetric	stationary; time dependent
 <b>Nonisothermal Reacting Flow</b>				
Brinkman Equations		—	3D, 2D, 2D axisymmetric	stationary; time dependent
Laminar Flow		—	3D, 2D, 2D axisymmetric	stationary; time dependent
 <b>Electrochemistry</b>				
Primary Current Distribution		cd	all dimensions	stationary; stationary with initialization; time dependent; time dependent with initialization; AC impedance, initial values; AC impedance, stationary; AC impedance, time dependent
Secondary Current Distribution				
Tertiary Current Distribution, Nernst–Planck (Electroneutrality, Water-Based with Electroneutrality, Supporting Electrolyte, Poisson)		tcd	all dimensions	stationary; stationary with initialization; time dependent; time dependent with initialization; AC impedance, initial values; AC impedance, stationary; AC impedance, time dependent

PHYSICS INTERFACE	ICON	TAG	SPACE DIMENSION	AVAILABLE STUDY TYPE
Aqueous Electrolyte Transport		aqt	all dimensions	stationary; stationary with initialization; time dependent; time dependent with initialization
Concentrated Electrolyte Transport		cet	all dimensions	stationary; stationary with initialization; time dependent; time dependent with initialization;
Electroanalysis		tcd	all dimensions	stationary; time dependent; AC impedance, initial values; AC impedance, stationary; AC impedance, time dependent; cyclic voltammetry
Electrode, Shell		els	3D, 2D, 2D axisymmetric	stationary; time dependent
Hydrogen Fuel Cell Interfaces		fc	all dimensions	stationary; time dependent; frequency domain
Water Electrolyzer Interfaces		fc	all dimensions	stationary; time dependent; frequency domain
<b>Fluid Flow</b>				
<b>Multiphase Flow</b>				
<b>Bubbly Flow</b>				
Laminar Bubbly Flow		bf	3D, 2D, 2D axisymmetric	stationary; time dependent
<b>Mixture Model</b>				
Mixture Model, Laminar Flow		mm	3D, 2D, 2D axisymmetric	stationary; time dependent
<b>Euler-Euler Model</b>				
Euler-Euler Model, Laminar Flow		ee	3D, 2D, 2D axisymmetric	stationary; time dependent

PHYSICS INTERFACE	ICON	TAG	SPACE DIMENSION	AVAILABLE STUDY TYPE
 <b>Phase Transport Mixture Model</b>				
Phase Transport, Mixture Model, Laminar Flow		—	3D, 2D, 2D axisymmetric	stationary; time dependent
 <b>Phase Transport</b>				
Phase Transport		phtr	all dimensions	stationary; time dependent
Phase Transport in Porous Media		phtr	all dimensions	stationary; time dependent
Phase Transport in Free and Porous Media Flow		phtr	all dimensions	stationary; time dependent
 <b>Porous Media and Subsurface Flow</b>				
Brinkman Equations		br	3D, 2D, 2D axisymmetric	stationary; time dependent
Darcy's Law		dl	all dimensions	stationary; time dependent
Multiphase Flow in Porous Media		—	all dimensions	stationary; time dependent
Multiphase Free and Porous Media Flow		—	3D, 2D, 2D axisymmetric	stationary; time dependent
Free and Porous Media Flow, Brinkman		fp	3D, 2D, 2D axisymmetric	stationary; time dependent
Free and Porous Media Flow, Darcy		—	3D, 2D, 2D axisymmetric	stationary; time dependent
 <b>Nonisothermal Flow</b>				
Brinkman Equations		—	3D, 2D, 2D axisymmetric	stationary; time dependent; stationary, one-way NITF; time dependent, one-way NITF

PHYSICS INTERFACE	ICON	TAG	SPACE DIMENSION	AVAILABLE STUDY TYPE
<b>Heat Transfer</b>				
Heat Transfer in Porous Media		ht	all dimensions	stationary; time dependent

### Tutorial of a Fuel Cell Cathode

One of the important aspects of fuel cell modeling is the mass transport through the gas diffusion and reactive layers. Gas concentration gradients may often be quite large and are strongly coupled to the reactions that take place.

Figure 4 shows an example 3D geometry of a cathode from a fuel cell with perforated current collectors. This geometry configuration can be used for self-breathing cathodes or in small experimental cells. Due to the perforation layout, a 3D model is needed in the study of the mass transport, current, and reaction distributions.

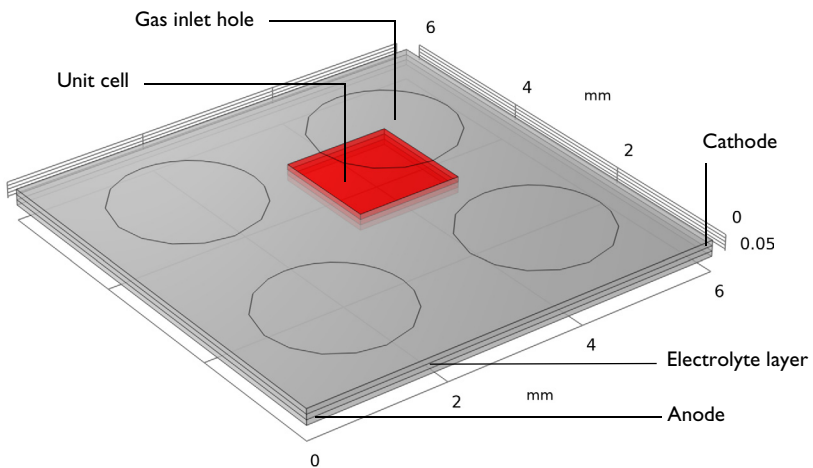
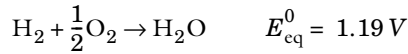

Figure 4: A fuel cell cathode with a perforated current collector.

The model couples this mass transport to a concentration-dependent Butler–Volmer electrochemical kinetic expression in a porous gas diffusion electrode (the cathode). Darcy’s law is used to define the convective velocity in the porous gas diffusion electrode, whereas diffusion is modeled using the Maxwell–Stefan equations. A note here is that the molar fractions of the reactants and products

(that is, oxygen and water vapor) are typically large (>10%), which makes Fickian diffusion an inappropriate assumption for modeling the diffusive mass transport. The electrochemical reaction for a PEM fuel cell to produce electrical energy is given by:



where  $E_{\text{eq}}^0$  denotes the standard equilibrium potential of the cell reaction, assuming all reactants reacting in the gas phase at atmospheric pressure.

At the anode Hydrogen Oxidation Reaction (HOR) yield protons:

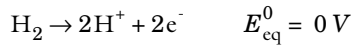

whereas on the cathode, water is produced via Oxygen Reduction Reaction (ORR):

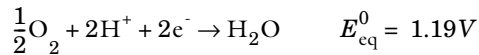

### ***Model Definition***

Figure 5 shows details for a unit cell, cut out from Figure 4. (In this case, the combination of a circular orifice and square unit cell eliminates the possibility to approximate the geometry with a rotationally symmetric model.) The circular hole in the collector acts as an inlet where the gas enters the modeling domain, and at this boundary the gas mixture composition and pressure is known. The upper and lower rectangular domains are the reaction-zone gas diffusion electrodes. They consist of a three-phase porous structure that contains the feed-gas mixture, an electronically conducting material covered with an electrocatalyst, and an ionically conducting electrolyte.

The middle domain corresponds to a solid electrolyte membrane, ionically interconnecting the two electrodes of the fuel cell. No reaction takes place in this domain and the current is conducted ionically. In addition, there are no pores present to allow gas to flow, nor any material present for electronic current conduction.

The gas diffusion electrodes are 0.075 mm thick, as is the electrolyte layer. The unit cell is 1.5-by-1.5 mm in surface, and the gas inlet hole has a radius of 1.0 mm.

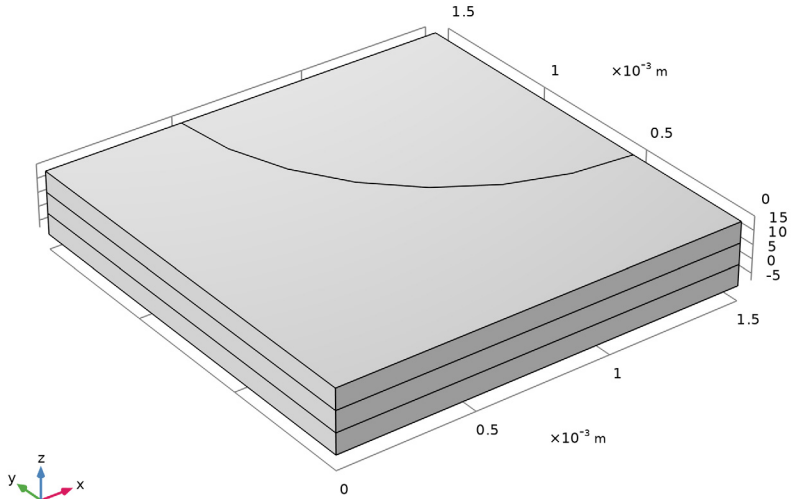

Figure 5: The modeled fuel cell unit cell. The quarter circle part of the top boundary is the surface of the cathode that is open to the feed gas inlet, while the rest of the top surface sits flush against a metal current collector. In the unit cell, the top domain is the porous cathode, the middle domain is the membrane, and the bottom domain is the porous anode.

The Hydrogen Fuel Cell interface models the electronic and ionic current balances and solves for the potentials  $\phi_s$  and  $\phi_l$  in the electrode and electrolyte phases, respectively. The anode side of the cell is grounded, whereas the current collector boundary at the cathode is set to a cell potential value.

The species (mass) transport is modeled by the Maxwell–Stefan equations for the mass fractions of oxygen, water, and nitrogen in the  $O_2$  gas phase. Mass transport is solved for in the cathode gas diffusion electrode domain only. Similarly, the pressure and the resulting velocity vector is solved for in the cathode gas diffusion electrode domain only using Darcy’s Law. (No mass transport effects are expected to occur at the hydrogen anode side). As boundary conditions, inlet molar fractions are set for the three gas species corresponding to a humidified air mixture at 90% relative humidity at atmospheric pressure.

The cell operates at 70°C. The reference equilibrium potentials for the higher temperature — the reference state — for each reaction are calculated from the standard free energies of formation and reaction entropies according to

$$E_{\text{eq, ref}}(T) = -\frac{(\Delta H - T\Delta S)}{nF}$$

where  $T$  denotes the temperature,  $n$  the number of electrons participating in the electrode reaction, and  $F$  Faraday's constant.

Generally, the equilibrium potentials of the electrode reactions will depend on the local partial pressures of the reacting species according to the Nernst Equation:

$$E_{\text{eq}} = E_{\text{eq, ref}}(T) - \frac{RT}{nF} \ln \prod_i \left( \frac{p_i}{p_{\text{ref}}} \right)^{\nu_i}$$

where  $\nu_i$  are the stoichiometric coefficients of the reacting species.

The cathode electrode kinetics of the cathode are defined using a Butler-Volmer type of expression according to

$$i_{\text{loc, O}_2} = i_{0, \text{ref, O}_2} \left( \left( \frac{p_{\text{H}_2\text{O}}}{p_{\text{ref}}} \right)^2 \exp\left( \frac{\alpha_{a, \text{O}_2} F \eta_{\text{ref, O}_2}}{RT} \right) - \frac{p_{\text{O}_2}}{p_{\text{ref}}} \exp\left( -\frac{\alpha_{c, \text{O}_2} F \eta_{\text{ref, O}_2}}{RT} \right) \right)$$

where  $p_i$  is the partial pressure of the reacting species,  $p_{\text{ref}} = 1 \text{ atm}$  is the reference pressure and  $\eta_{\text{ref}}$ , the overpotential with respect to the reference state, is defined as

$$\eta_{\text{ref, O}_2} = \phi_s - \phi_l - E_{\text{eq, ref, O}_2}$$

The local current density expression in the cathode is multiplied by a specific area of  $10^9 \text{ m}^2/\text{m}^3$  to create a volumetric current source term in the electrode domain. Assuming ideal kinetics according to the mass action law,  $\alpha_{a, \text{O}_2} + \alpha_{c, \text{O}_2} = n$ .

For the anode, the kinetics is assumed to be so fast that a linearized Butler-Volmer expression may be used on the anode boundary.

$$i_{\text{loc, H}_2} = i_{0, \text{ref, H}_2} \left( \frac{p_{\text{H}_2}}{p_{\text{ref}}} \exp\left( \frac{\alpha_{a, \text{H}_2} F \eta_{\text{ref, H}_2}}{RT} \right) - \exp\left( -\frac{\alpha_{c, \text{H}_2} F \eta_{\text{ref, H}_2}}{RT} \right) \right)$$

$$i_{\text{loc, H}_2} \approx i_{0, \text{ref, H}_2} \left( \frac{p_{\text{H}_2}}{p_{\text{ref}}} \right)^{\frac{\alpha_{c, \text{H}_2}}{n}} \left( \frac{nF\eta}{RT} \right)$$

assuming  $\alpha_{a, \text{H}_2} + \alpha_{c, \text{H}_2} = n$  and where, since the anode boundary is grounded, the overpotential is defined as

$$\eta = 0 - \phi_l - E_{\text{eq, H}_2}$$

The partial pressure of hydrogen is assumed to be constant on the anode boundary. No mass transport effects nor any current distribution along the depth of the anode electrode are hence considered.

In the first part of the model instruction below, a secondary (not concentration dependent) current distribution is modeled. In the second part, mass, and momentum transport is incorporated in the  $O_2$  gas phase mixture (cathode domain), using Maxwell–Stefan diffusion and Darcy’s Law, respectively. In both parts of the tutorial, the model is solved for a range of cell potential values (0.5 V to 1 V in steps of 0.1 V) by the use of an auxiliary sweep in the stationary solver.

## Results and Discussion

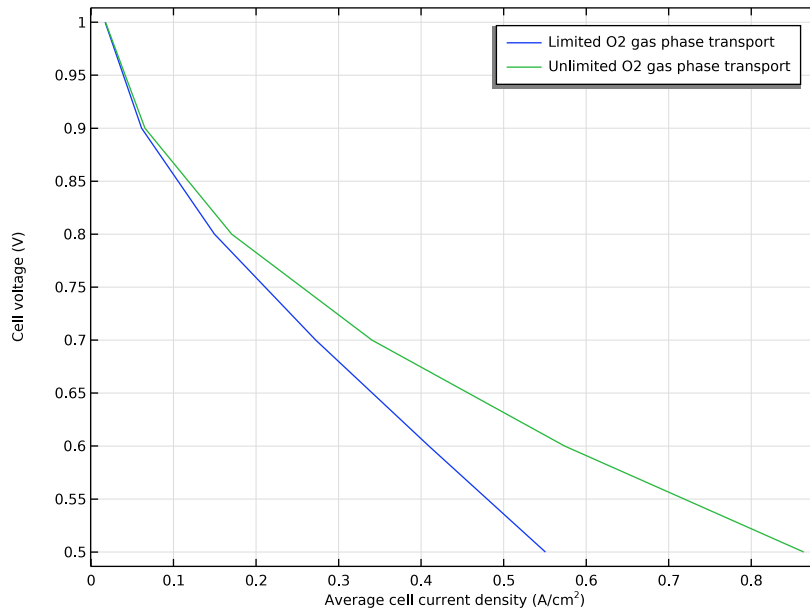

Figure 6: Polarization plot.

Figure 6 shows the polarization plot for the two scenarios investigated: limited and unlimited  $O_2$  gas phase transport. It can be seen that higher average cell current densities are achieved for the unlimited  $O_2$  gas phase transport scenario (that is, when no mass and momentum transport limitations are present).

Note that the plots and discussion in the rest of this section correspond to the limited  $O_2$  gas phase transport scenario, where diffusion and flow (in the cathode domain) have been considered, coupled to charge transport and the electrochemical reactions.

E\_cell(4)=0.7 V

Species O2: Mole fraction (1)

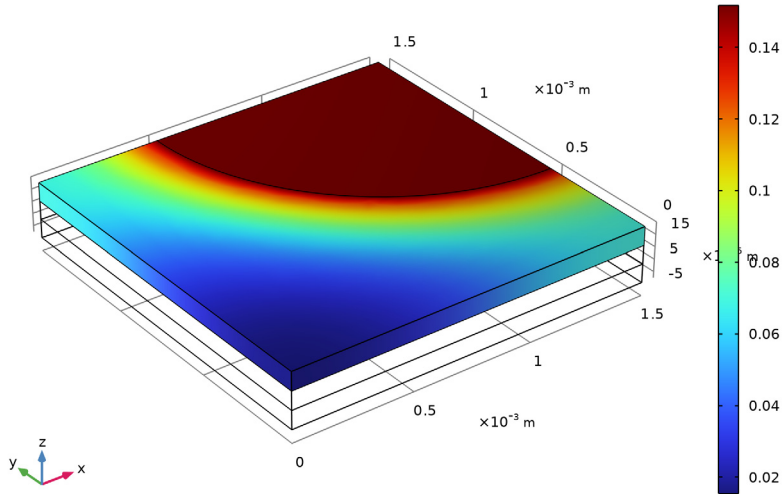

Figure 7: Mole fraction of oxygen at cell voltage of 0.7 V.

Figure 7 shows the oxygen mole fraction at cell voltage of 0.7 V. The figure shows that mole fraction variations are small along the thickness of the cathode, while they are substantially larger along the electrode's width.

E<sub>cell</sub>(4)=0.7 V

Multislice: Pressure (Pa) Streamline: Velocity field

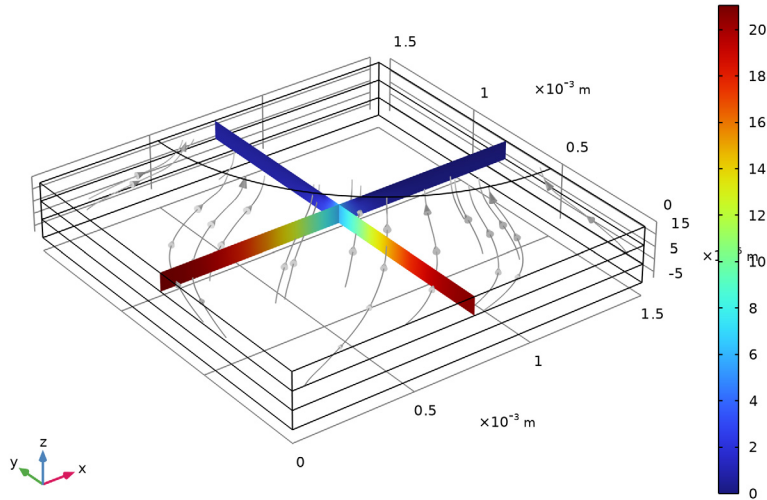

Figure 8: Pressure and velocity for the gas phase in the cathode's porous reactive layer at cell voltage of 0.7 V.

Figure 8 shows the pressure and gas velocity streamlines in the porous cathode at the same cell voltage. There is a significant velocity peak at the edge of the inlet orifice. This is caused by the contributions of the reactive layer underneath the current collector because in this region the convective flux dominates the mass transport. The gas flows from the interior of the cell toward the circular hole. The reason for this is the oxygen reduction reaction, with the creation of two water gas molecules, being transported out of the cell, per oxygen molecule entering the cell.

The electrochemical reaction rate, represented by the local current density, is related to both the local overpotential and oxygen concentration in the cathode domain. Figure 9 depicts the local overpotential (at cell voltage of 0.7 V), which gets more negative toward the electrolyte domain.

$E_{\text{cell}(4)}=0.7 \text{ V}$

Overpotential (V)

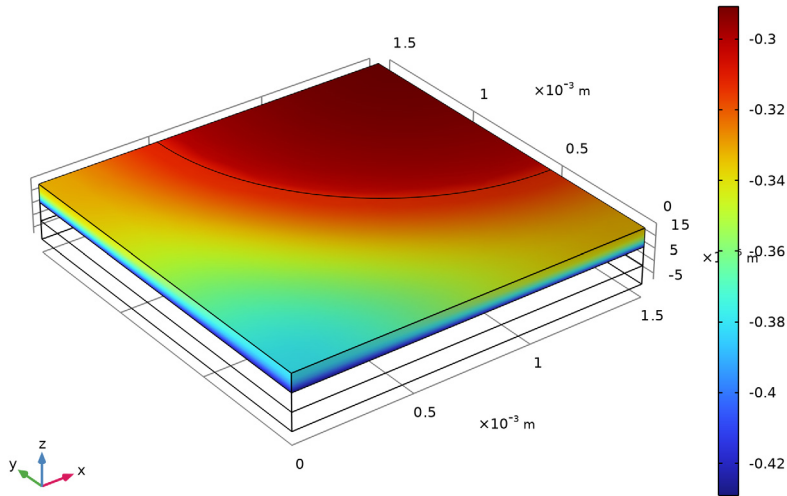

Figure 9: Local overpotential in the cathode reactive layer at cell voltage of 0.7 V.

The combination of the overpotential and oxygen concentration distributions will result in a highly uneven reaction rate in the reactive layer. One way to study the distribution of the reaction rate is to plot the ionic current density at the bottom boundary of the membrane layer. Figure 10 shows such a plot at cell voltage of 0.7 V.

The current-density distribution shows that the variations are rather large. The reaction rate and the current production are higher beneath the orifice and decrease as the distance to the gas inlet increases. This means that the mass transport of reactant dictates the electrode's efficiency for this design at these particular conditions.

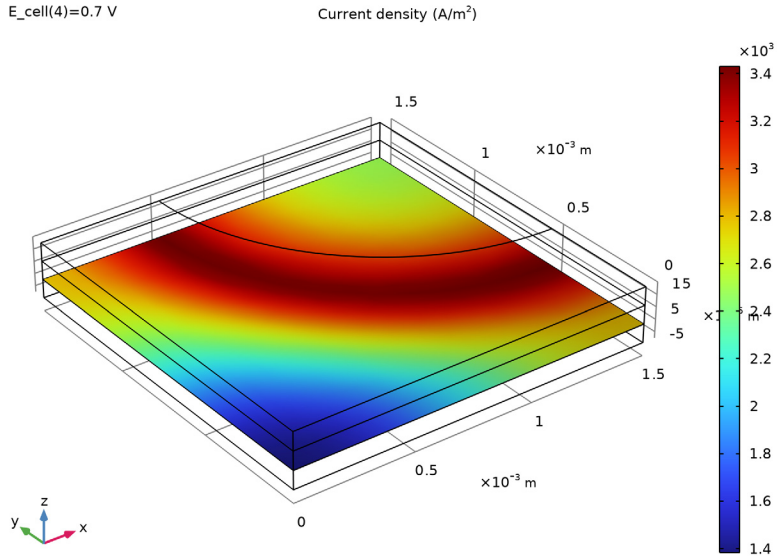

Figure 10: Current density perpendicular to the lower membrane boundary at cell voltage of 0.7 V.

Figure 11 shows a plot of the cell-integrated power losses associated with the different processes in the cell. For this cell, the power losses due to kinetic activation of the oxygen reduction reaction dominate the losses, followed by the electrolyte transport losses.

By dividing the loss in power by the cell current, we can also compute the corresponding cell overpotentials, as shown in Figure 12. The oxygen reduction overpotential is highly nonlinear with respect to the cell current density. This stems from the Butler-Volmer kinetics deployed in the model. The electrolyte transport overpotential has a more linear behavior with respect to the cell current density.

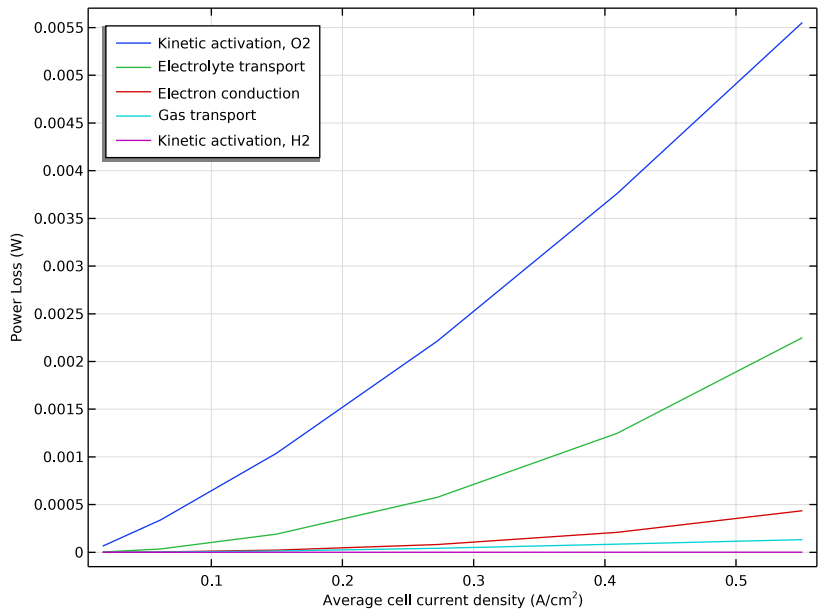

Figure 11: Cell-integrated power losses.

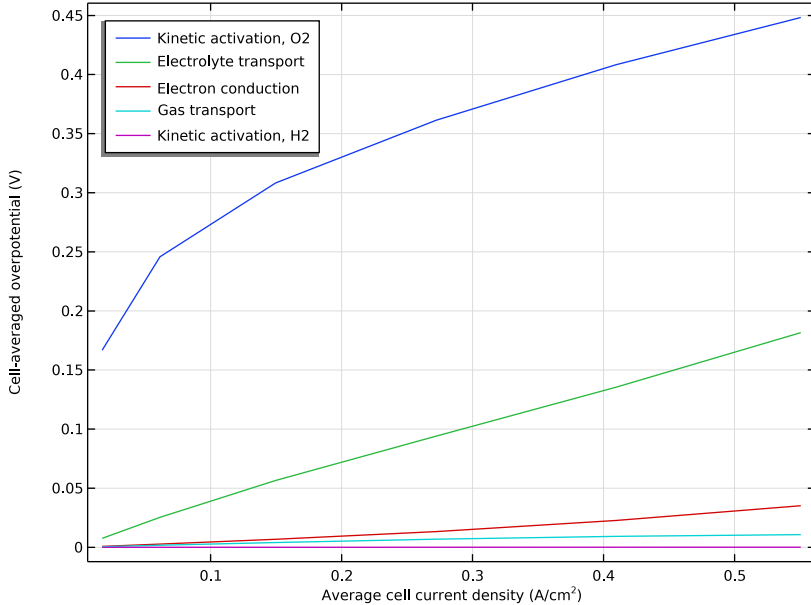





Figure 12: Cell overpotentials.



The following instructions show how to formulate, solve, and reproduce this model.

## Model Wizard

1 To start the software, double-click the COMSOL icon on the desktop or Start menu of the computer. When the software opens, you can choose to use the Model Wizard to create a new COMSOL model or Blank Model to create one manually. For this tutorial, click the Model Wizard button.

If COMSOL is already open, you can start the Model Wizard by selecting New  from the File menu and then click Model Wizard . The Model Wizard guides you through the first steps of setting up a model.

- 2 First you select the dimension of the modeling space. In the Model Wizard window, click  3D.
- 3 In the Select Physics tree, select Electrochemistry > Hydrogen Fuel Cells > Proton Exchange (fc).
- 4 Click Add.



- 5 Click  Study.
- 6 In the Select Study tree, select Preset Studies for Selected Physics Interfaces > Stationary with Initialization.
- 7 Click  Done.

## Global Definitions

---

Load the model parameters from a text file.

### Parameters

- 1 In the Home toolbar click Parameters  and select Parameters 1 .

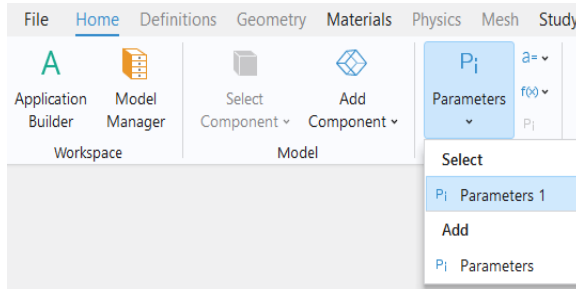

**Note:** On Linux and Mac, the Home toolbar refers to the specific set of controls near the top of the Desktop.

- 2 In the Settings window for Parameters locate the Parameters section. Click Load from File .

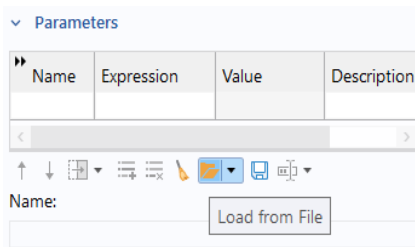

- 3 In the application library folder Fuel\_Cell\_and\_Electrolyzer\_Module\Fuel\_Cells on your computer, double-click the file `fue1_cell_cathode_parameters.txt` to import it to the Parameters table. Note that the location of the files used in this exercise may vary depending on the installation. For example, if the installation is on your hard drive, the file path might be similar to `C:\Program Files\COMSOL\COMSOL64\applications\`.

## Geometry I

---

Now draw the model geometry. Use blocks to define the electrolyte and the porous electrode domains. Then use a workplane to draw the inlet hole at the top of the porous electrode. Facilitate geometry selection later (when setting up the physics interfaces) by enabling Resulting objects selection and renaming the geometry objects.

Begin by setting the default length unit to millimeters.

- 1 In the Model Builder under Component 1, click Geometry 1 .
- 2 In the Settings window for Geometry locate the Units section. From the Length unit list, choose mm.

### Create the First Block

- 1 In the Geometry toolbar click Block .

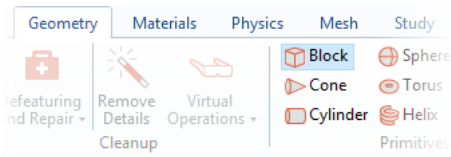

- 2 In the Model Builder under Geometry 1, click Block 1 .
- 3 In the Settings window for Block, type Membrane in the Label text field.
- 4 In the Settings window for Block locate the Size section.

- In the Width text field, type S.
- In the Depth text field, type S
- In the Height text field, type d.



- 5 Locate the Selections of Resulting Entities section. Enable the Resulting objects selections checkbox. By enabling Resulting objects selection here, the domain created by this rectangular block will also be available as a named domain option later on when setting up the physics.
- 6 Click the Build Selected button .

## Duplicate the Block and Change z Position

7 Right-click Membrane  and choose Duplicate .

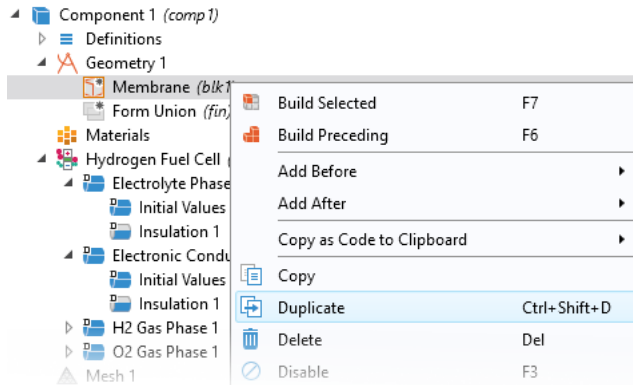

8 In the Label text field, type Cathode Gas Diffusion Electrode.

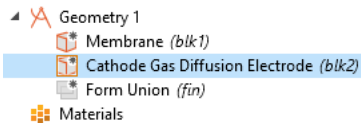

9 In the Settings window for Block locate the Position section. In the z text field, type d.

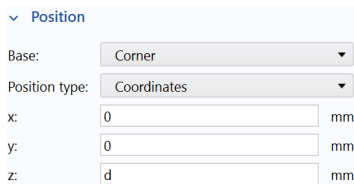

## Duplicate the Cathode Block to Draw the Anode

1 Right-click Cathode Gas Diffusion Electrode and choose Duplicate.

2 In the Settings window for Block, type Anode Gas Diffusion Electrode in the Label text field.

3 Locate the Position section. In the z text field, type -d.

4 Click  Build Selected. Your geometry should now look like this:

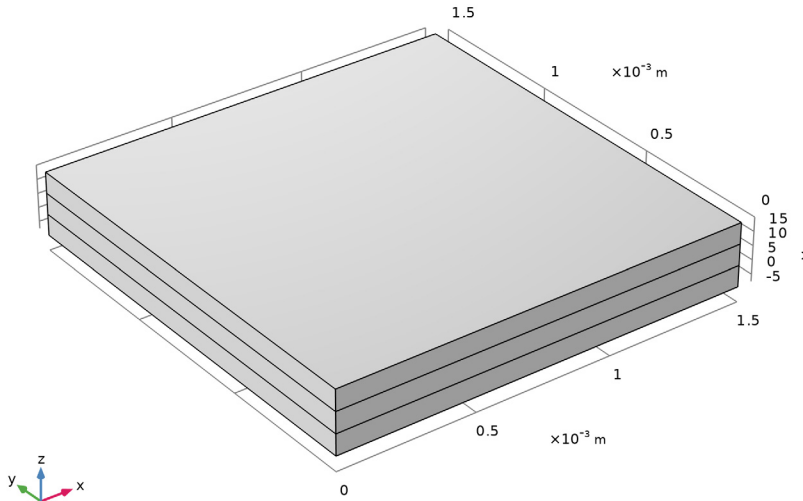

### Create a Work Plane for Drawing the Inlet Hole

Proceed to draw the inlet hole, placed at the top of the cathode gas diffusion electrode block.

1 In the Geometry toolbar click Work Plane .

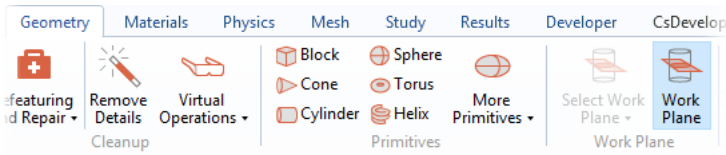

2 In the Label text field, type Inlet.

3 In the Settings window for Work Plane locate the Plane Definition section. In the z-coordinate field, type  $2*d$ .

4 Locate the Selections of Resulting Entities section. Enable the Resulting objects selections checkbox.

## Draw the Inlet Hole

- 1 In the Model Builder under Geometry 1 > Inlet, right-click Plane Geometry and choose Circle .

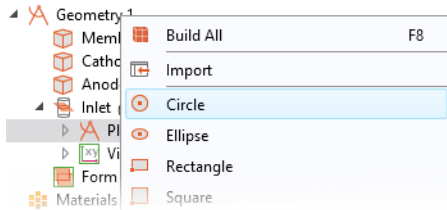

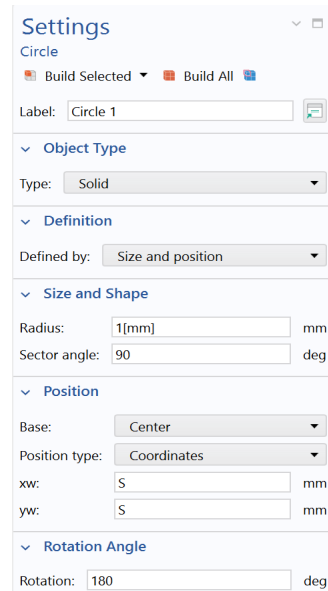

- 2 In the Settings window for Circle locate the Size and Shape section.
  - In the Radius text field, type 1.
  - In the Sector angle text field, type 90.
- 3 Locate the Position section.
  - In the xw text field, type S.
  - In the yw text field, type S.
- 4 Locate the Rotation Angle section. In the Rotation text field, type 180.

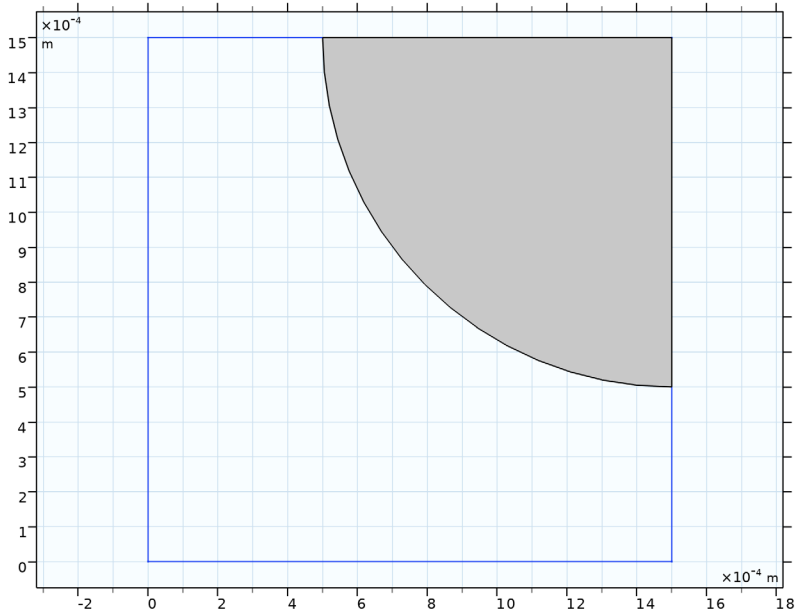

- 5 Click the Build Selected button . Your work plane 2D geometry should now contain a quarter of a circle, looking as follows:



*Form a Union to Finalize the Geometry*

- 1 In the Model Builder click the Form Union node  and then click the Build Selected button .

- 2 Click the Zoom Extents button  in the Graphics toolbar. The final 3D geometry should now look like this:

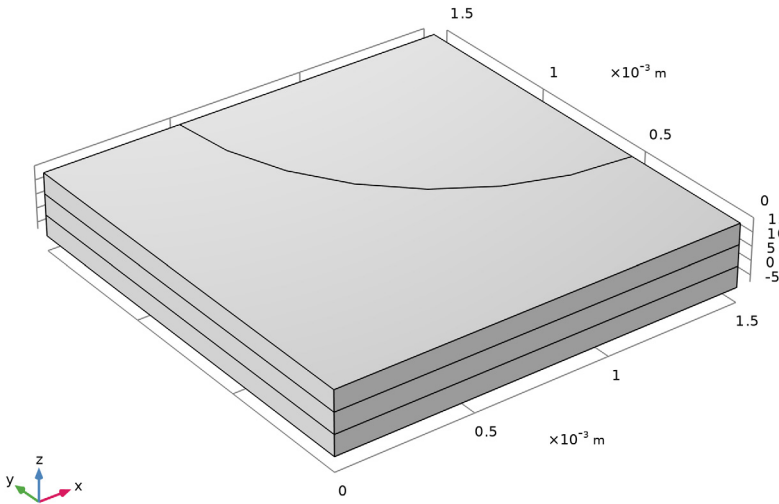

## Hydrogen Fuel Cell

---

In the first part of the tutorial, a secondary (not concentration dependent) current distribution is modeled. Diffusion is hence disabled in the H<sub>2</sub> and O<sub>2</sub> gas phase mixtures. The default gas species are hydrogen and water on the anode side, and oxygen, nitrogen, and water on the cathode side.

- 1 In the Model Builder window, under Component 1 (comp1) click Hydrogen Fuel Cell (fc).

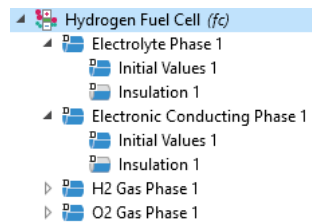

H2 Gas Mixture

Include species

H2O

N2

CO2

CO

CH4

Auxiliary species

— Transport mechanisms —

Include gas phase diffusion

Use Darcy's Law for momentum transport

— Reactions —

Include H2O(l) in reaction stoichiometry

---

O2 Gas Mixture

Include species

H2O

N2

CO2

CO

Auxiliary species

— Transport mechanisms —

Include gas phase diffusion

Use Darcy's Law for momentum transport

— Reactions —

Include H2O(l) in reaction stoichiometry

**2**In the Settings window for Hydrogen Fuel Cell, locate the H2 Gas Mixture section, and in the Transport mechanisms subsection, clear the Include gas phase diffusion checkbox.

**3**Similarly, locate the O2 Gas Mixture section and check the Use Darcy's Law for momentum transport checkbox here.

A number of domain nodes, defining the different phases present in the model were added by default. The active selection of these nodes are locked, but may be controlled by adding additional domain nodes (such as Membrane, and so on). Start by adding these additional nodes, and make the corresponding selections on the geometry.

## Membrane

- 1 In the Physics toolbar, click  Domains and choose Membrane.
- 2 In the Settings window for Membrane, locate the Domain Selection section.
- 3 From the Selection list, choose Membrane.

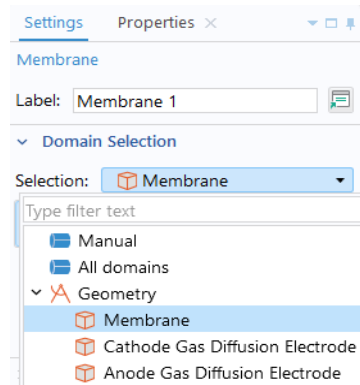

## H2 Gas Diffusion Electrode

- 1 In the Physics toolbar, click  Domains and choose H2 Gas Diffusion Electrode.
- 2 In the Settings window for H2 Gas Diffusion Electrode, locate the Domain Selection section.
- 3 From the Selection list, choose Anode Gas Diffusion Electrode.

## O2 Gas Diffusion Electrode

- 1 In the Physics toolbar, click  Domains and choose O2 Gas Diffusion Electrode.
- 2 In the Settings window for O2 Gas Diffusion Electrode, locate the Domain Selection section.
- 3 From the Selection list, choose Cathode Gas Diffusion Electrode.

## Electrolyte Phase

The Electrolyte Phase node should now be active on all three domains. Define the conductivity in the Electrolyte Phase node by using the Fuel Cell and Electrolyzer material library, which contains conductivity data for some common electrolytes.

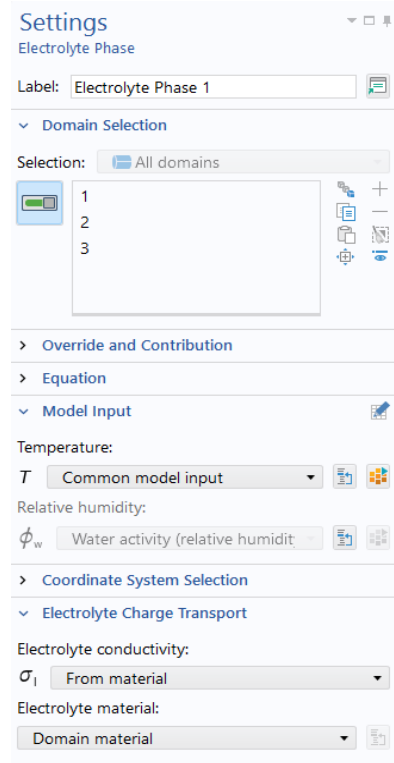

## Add Electrolyte Material

- 1 In the Home toolbar, click Add Material.
- 2 Go to the Add Material window. In the tree, select Fuel Cell and Electrolyzer > Polymer Electrolytes > Nafion, EW 1100, Vapor Equilibrated, Protonated, and choose Add to Component.
- 3 In the Home toolbar, click Add Material to close the Add Material window.

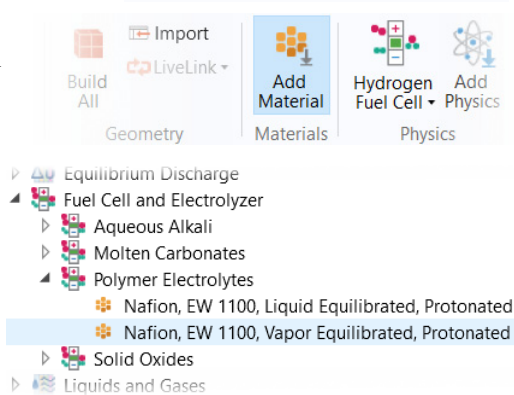

The polymer electrolyte conductivity depends on the temperature and the relative humidity. Specify the temperature globally in the Default Model Inputs node. The temperature defined in the Default Model Inputs node may be accessed by multiple physics nodes in the model (such as the Nernst and Butler-Volmer equations that will be set later).

### *Set Temperature in Default Model Inputs*

- 1 In the Model Builder window, under Global Definitions click Default Model Inputs.
- 2 In the Settings window for Default Model Inputs, locate the Browse Model Inputs section.
- 3 In the tree, select General > Temperature (K) - minput.T.
- 4 Find the Expression for remaining selection subsection. In the Temperature text field, type  $\tau$ .

### *Membrane*

Also specify the relative humidity for the membrane electrolyte in the Membrane node.

- 1 In the Model Builder window, under Component 1 > Hydrogen Fuel Cell, click Membrane 1.
- 2 In the Settings window for Membrane, locate the Electrolyte Water Activity for Material Model Input section.
- 3 In the  $a_w$  text field, type RH.

Note that the water activity in the polymer of the gas diffusion electrodes (GDEs) is approximated to be in equilibrium with the adjacent gas phase in the pores, and is hence automatically set equal to the relative humidity in the GDEs.

### *H2 Gas Phase*

The H2 Gas Phase node should be active in domain 1 only.

Set up the composition of the H2 gas phase mixture using the Humidified mixture option.

- 1 In the Model Builder window, click H2 Gas Phase 1.
- 2 In the Settings window for H2 Gas Phase, locate the Composition section.
- 3 From the Mixture specification list, choose Humidified mixture.
- 4 In the  $RH_{\text{hum}}$  text field, type RH.
- 5 In the  $T_{\text{hum}}$  text field, type  $\tau$ .

## O2 Gas Phase

The O2 Gas Phase node should be active in domain 3 only.

Similarly, set up the initial composition of the O2 gas phase mixture using the Humidified air option.

- 1 In the Model Builder window, click O2 Gas Phase 1.
- 2 In the Settings window for O2 Gas Phase, locate the Composition section.
- 3 From the Mixture specification list, choose Humidified air.
- 4 In the  $RH_{\text{hum}}$  text field, type RH.
- 5 In the  $T_{\text{hum}}$  text field, type T.

## H2 Gas Diffusion Electrode

Next set up the properties of the H2 Gas Diffusion Electrode node. Note that the electrolyte volume fraction is used to calculate the effective electrolyte conductivity in the porous gas diffusion electrode.

- 1 In the Model Builder window, click H2 Gas Diffusion Electrode 1.
- 2 In the Settings window for H2 Gas Diffusion Electrode, locate the Electrode Charge Transport section.
- 3 In the  $\sigma_s$  text field, type sigma\_s.
- 4 Locate the Effective Electrolyte Charge Transport section. In the  $\epsilon_l$  text field, type eps\_1.

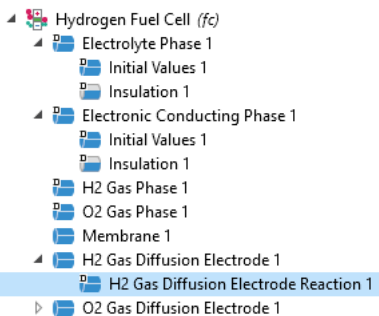

## H2 Gas Diffusion Electrode Reaction

The thermodynamics and kinetics of the hydrogen oxidation reaction are set in the child node that is added by default. Note that the reference equilibrium potential is calculated automatically when the default Built in option is used.

- 1 In the Model Builder window, click H2 Gas Diffusion Electrode Reaction 1.
- 2 In the Settings window for H2 Gas Diffusion Electrode Reaction, locate the Electrode Kinetics section.
- 3 From the Kinetics expression type list, choose Linearized Butler-Volmer.
- 4 In the  $i_{0,\text{ref}}(T)$  text field, type  $i_{0,\text{ref\_H2}}$ .
- 5 Locate the Active Specific Surface Area section. In the  $\alpha_v$  text field, type Av.

## O2 Gas Diffusion Electrode

Set up the properties of the O2 Gas Diffusion Electrode node in the same way.

- 1 In the Model Builder window, click O2 Gas Diffusion Electrode 1.
- 2 In the Settings window for O2 Gas Diffusion Electrode, locate the Electrode Charge Transport section.
- 3 In the  $\sigma_s$  text field, type `sigma_s`.

## O2 Gas Diffusion Electrode Reaction

The thermodynamics and kinetics of the oxygen reduction reaction are similarly set in the child node that is added by default. Note that the reference equilibrium potential is calculated automatically when the default Built in option is used.

- 1 In the Model Builder window, click O2 Gas Diffusion Electrode Reaction 1.
- 2 In the Settings window for O2 Gas Diffusion Electrode Reaction, locate the Electrode Kinetics section.
- 3 In the  $i_{0,\text{ref}}(T)$  text field, type `i0_ref_O2`.
- 4 Locate the Active Specific Surface Area section. In the  $a_v$  text field, type `Av`.

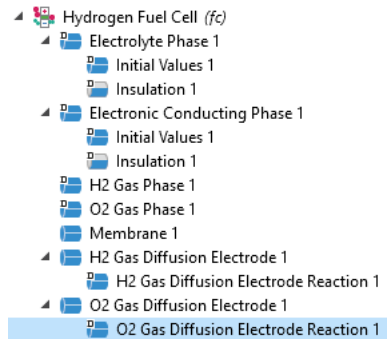

## Ground Boundary Condition on the Anode Side

Finalize the secondary current distribution model by setting up the boundary conditions for the potentials in the electronic conducting phase.

- 1 In the Model Builder window, click Electronic Conducting Phase 1.
- 2 In the Physics toolbar, click  Attributes and choose Electric Ground.
- 3 Select Boundary 3 only.

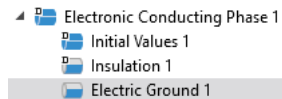

## Potential Boundary Condition on the Cathode Side

- 1 In the Model Builder window, click Electronic Conducting Phase 1.
- 2 In the Physics toolbar, click  Attributes and choose Electric Potential.

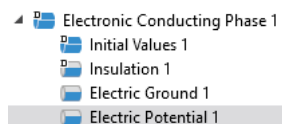

- 3 Select Boundary 10 only.
- 4 In the Settings window for Electric Potential, locate the Electric Potential section, and in the  $\phi_{s,bnd}$  text field, type E\_cell.

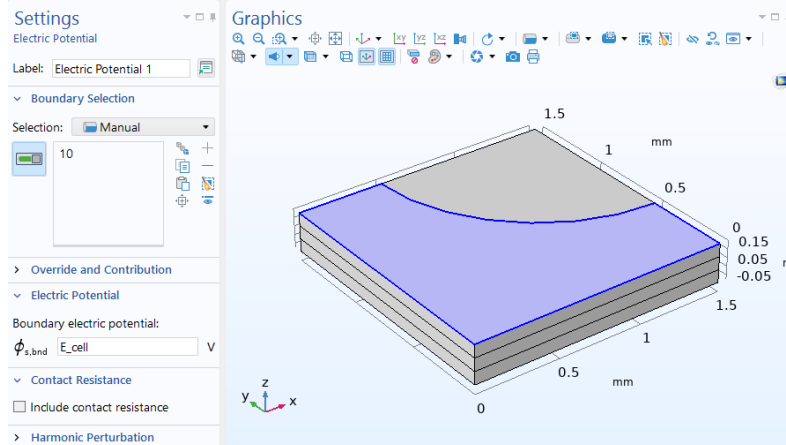

## Create the Mesh

The default mesh that will be used automatically is fairly coarse, featuring only one or two mesh elements in the  $z$  direction. To improve accuracy of the results, the mesh needs to be refined. For this geometry a swept mesh can be used to get accurate control of the number of elements in the  $z$  direction. Inspect the default mesh before refining it.

- 1 In the Model Builder window, under Component 1 (comp1) right-click Mesh 1 and choose Build All.

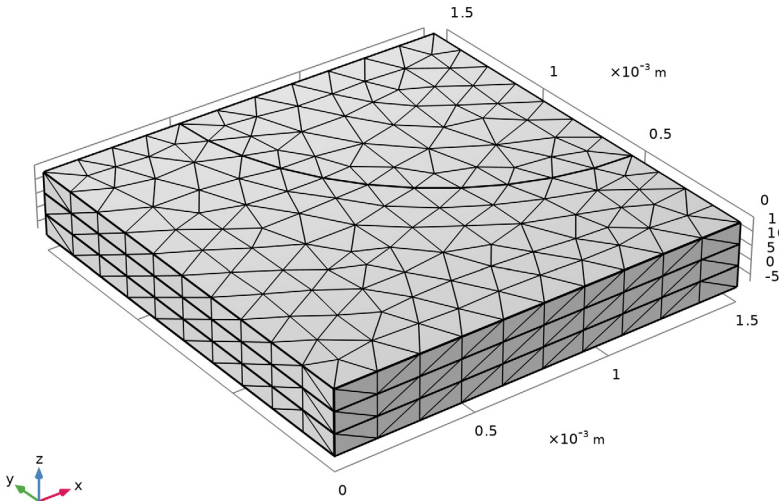

### *Modify the General Size Setting*

- 1 In the Settings window for Mesh, locate the Physics-Controlled Mesh section.
- 2 From the Element size list, choose Fine.

### *Add a Swept Mesh*

- 1 In the Mesh toolbar, and choose Swept.
- 2 In the Settings window for Swept, click to expand the Source Faces section.
- 3 Select Boundaries 10 and 14 only.

### *Add a Distribution for the Cathode*

- 1 Right-click Swept 1 and choose Distribution.
- 2 In the Settings window for Distribution, locate the Domain Selection section.
- 3 From the Selection list, choose Cathode Gas Diffusion Electrode.
- 4 Locate the Distribution section. From the Distribution type list, choose Predefined.

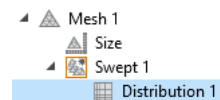

We will create a mesh with thinner elements in the cathode gas diffusion electrode domain toward the boundary facing the membrane domain.

- 5 In the Element ratio text field, type 5.
- 6 Select the Reverse direction checkbox.
- 7 Click  Build All.

The mesh should now look as follows:

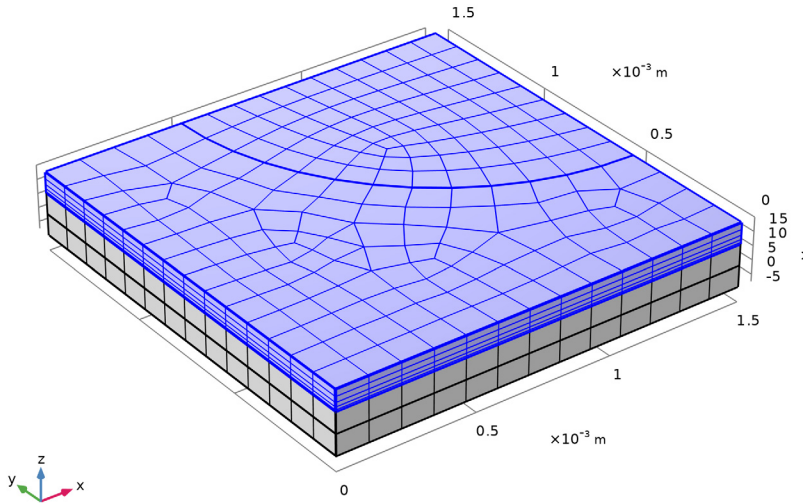

### *Swept 1*

To improve the resolution along the current collector-inlet hole edge, and the interior of the electrode, also add some Size nodes.

#### *Size 1*

- 1 Right-click Swept 1 and choose Size.
- 2 In the Settings window for Size, locate the Geometric Entity Selection section.
- 3 From the Geometric entity level list, choose Edge.
- 4 Select Edge 19 only.
- 5 Locate the Element Size section. From the Predefined list, choose Extra fine.

#### *Size 2*

- 1 Right-click Swept 1 and choose Size.
- 2 In the Settings window for Size, locate the Geometric Entity Selection section.
- 3 From the Geometric entity level list, choose Edge.

- 4 Select Edges 10 and 11 only.
- 5 Locate the Element Size section. From the Predefined list, choose Finer.

### Size 3

- 1 Right-click Swept 1 and choose Size.
- 2 In the Settings window for Size, locate the Geometric Entity Selection section.
- 3 From the Geometric entity level list, choose Point.
- 4 Select Point 4 only.
- 5 Locate the Element Size section. From the Predefined list, choose Extra fine.
- 6 Click  Build All.

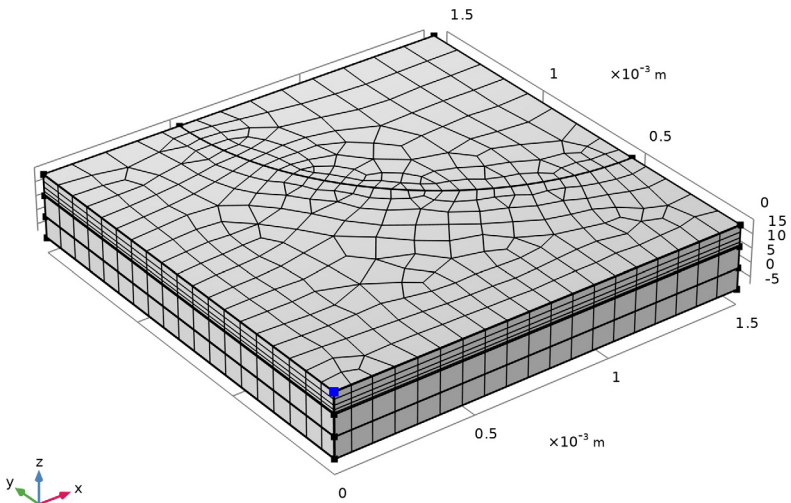
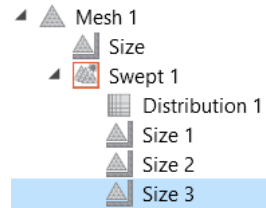

## Compute the Solution

The settings for the secondary current distribution model are now complete.

- 1 In the Home toolbar, click  Compute.

## Default Plots

Inspect the default plots.

In the Electrode Potential with Respect to Ground (fc) toolbar, click  Plot. The electrode potential plot should look as follows:

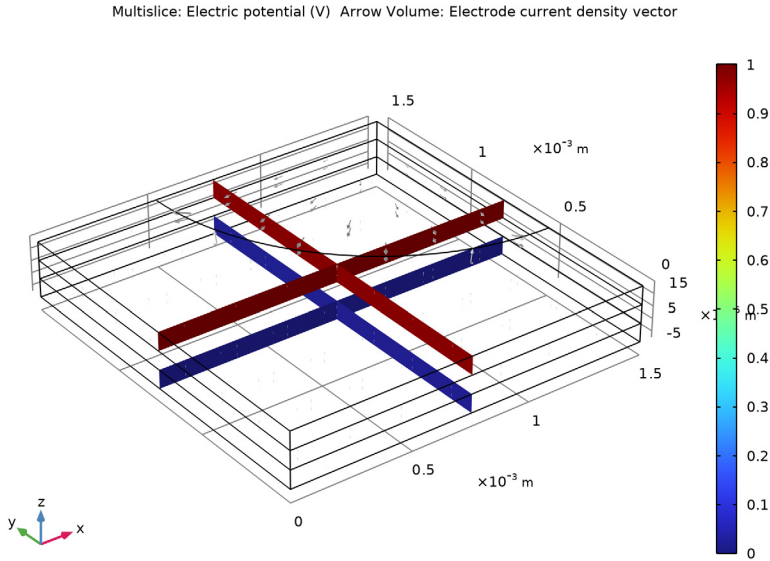

## Compute a Polarization Curve

We will now compute and plot a polarization curve — that is, solve for a range of cell potentials — and plot these versus the average cell current density.

*Set up a Boundary Probe for the Average Cell Current Density*

First introduce a boundary probe for the average cell current density at the anode gas diffusion electrode boundary.

In the Definitions toolbar, click  Probes and choose Boundary Probe.

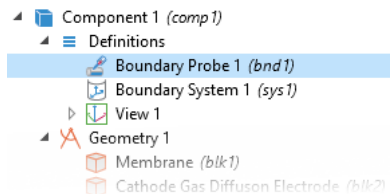

- 2 In the Settings window for Boundary Probe, type  $I_{avg}$  in the Variable name text field.
- 3 Select Boundary 3 only.
- 4 In the Settings window for Boundary Probe, click Replace Expression in the upper-right corner of the Expression section. From the menu, choose Component 1 (comp1) > Hydrogen Fuel Cell >  $fc.nIs$  - Normal electrode current density -  $A/m^2$ .
- 5 Change the sign of the expression so that it reads  $-fc.nIs$ .
- 6 Locate the Expression section. In the Table and plot unit field, type  $A/cm^2$ .
- 7 Select the Description checkbox and in the associated text field, type Average cell current density.

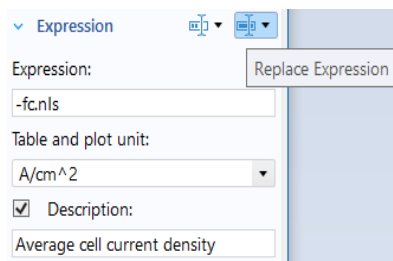

### Add an Auxiliary Sweep and Resolve

Set up an auxiliary sweep to solve for a range of cell potential values and compute the model again.

- 1 In the Model Builder window, under Study 1 click Step 2: Stationary.
- 2 In the Settings window for Stationary, click to expand the Study Extensions section.
- 3 Select the Auxiliary sweep checkbox.
- 4 Click  $+$  Add.
- 5 In the table, enter the following settings:

PARAMETER NAME	PARAMETER VALUE LIST	PARAMETER UNIT
$E_{cell}$ (Cell voltage)	$range(1,-0.1,0.5)$	V

- 6 In the Home toolbar, click  $=$  Compute.

### Polarization Curve

A probe plot for the average current density was created by default. Modify it as follows:

- 1 In the Model Builder window, under Results click Probe Plot Group 3.
- 2 In the Label text field, type Polarization Curve.

- 3 In the Settings window for 1D Plot Group, locate the Plot Settings section.
- 4 Select the Flip the x- and y-axes checkbox.
- 5 Select the y-axis label checkbox.
- 6 In the associated text field, type Cell voltage (V).
- 7 In the Polarization Curve toolbar, click  Plot.

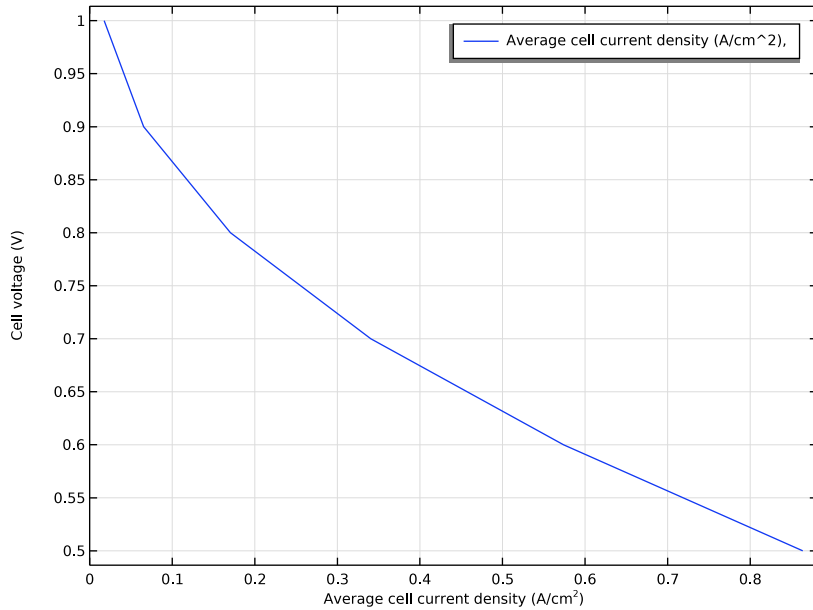

## Add Mass Transport and Fluid Flow to the Model

Now we start the second part of the tutorial to incorporate mass and momentum transport. Include mass transport using Maxwell-Stefan diffusion and momentum transport using Darcy's Law in the O<sub>2</sub> gas phase mixture.

### Enable Diffusion and Darcy's Law

- 1 In the Model Builder window, under Component 1 (comp1) click Hydrogen Fuel Cell (fc)
- 2 In the Settings window for Hydrogen Fuel Cell, locate the O<sub>2</sub> Gas Mixture section.
- 3 Find the Transport mechanisms subsection. Select the Include gas phase diffusion checkbox.
- 4 Select the Use Darcy's Law for momentum transport checkbox.

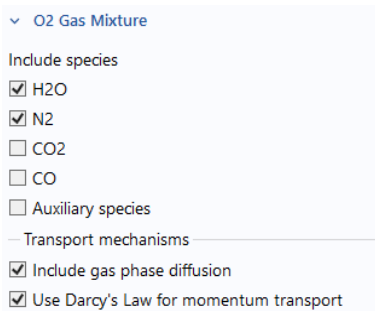

### Set Initial Values for O<sub>2</sub> Gas Phase

Inspect the settings of the O<sub>2</sub> Gas Phase node. Note that since you are now including diffusion in the model, the composition values you specified earlier are no longer visible. (Settings for Diffusion are now present instead.) The initial and inlet conditions (composition and pressure) of the O<sub>2</sub> gas phase mixture are now specified using child nodes. The gas composition is specified using the Humidified air option. Set up the initial and inlet conditions (composition and pressure) of the O<sub>2</sub> gas phase mixture.

- 1 Under O<sub>2</sub> Gas Phase 1, click Initial Values 1.
- 2 In the Settings window for Initial Values, locate the Initial Composition section.
- 3 From the Mixture specification list, choose Humidified air.
- 4 In the  $RH_{\text{hum}}$  text field, type RH.
- 5 In the  $T_{\text{hum}}$  text field, type T.

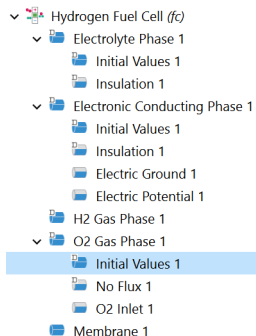

### Specify the Inlet for O<sub>2</sub> Gas Phase

The same parameter values that were used for the initial values are used to specify the inlet mole fractions.

- 1 In the Model Builder window, click O2 Gas Phase 1.
- 2 In the Physics toolbar, click  Attributes and choose O2 Inlet.
- 3 In the Settings window for O2 Inlet, locate the Boundary Selection section.
- 4 From the Selection list, choose Inlet.
- 5 Locate the Inlet Flow Type section.
- 6 From the Inlet flow type list, choose Mixture composition constraint.

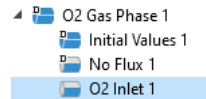

### *O2 Gas Diffusion Electrode 1*

Finally, set up the gas transport properties in the O2 Gas Diffusion Electrode node.

- 1 In the Model Builder window, click O2 Gas Diffusion Electrode 1.
- 2 In the Settings window for O2 Gas Diffusion Electrode, locate the Gas Transport section.
- 3 In the  $\epsilon_g$  text field, type `eps_gas`.
- 4 In the  $\kappa_g$  text field, type `perm`.

Note that the effect of varying concentration is automatically taken into account in the built-in thermodynamic and kinetic expressions of the oxygen reduction reaction in the O2 Gas Diffusion Electrode Reaction child node, and appropriate mass sources resulting from the electrochemical reaction in the O2 gas phases mixture are automatically defined. Hence, no additional settings are required in this node.

## **Store the Old Probe Table Data Before Recomputing**

---

Before proceeding to solve the model with transport effects, duplicate the probe table and rename the copy appropriately.

- 1 In the Model Builder window, expand the Results > Tables node.
- 2 Right-click Probe Table 1 and choose Duplicate.
- 3 In the Settings window for Table, type Unlimited O<sub>2</sub> gas phase transport in the Label text field.

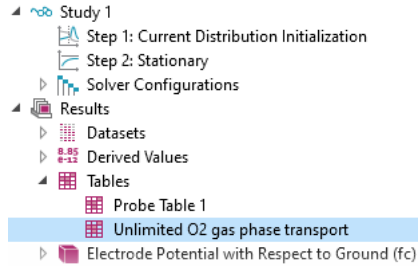

## Remove the Old Study Sequence and Recompute

---

In order to generate new default plots related to the introduced mass transport, remove the old study sequence before recomputing.

- 1 In the Model Builder window, under Study 1 right-click Solver Configurations and choose Delete Configurations.
- 2 In the Home toolbar, click  Compute.

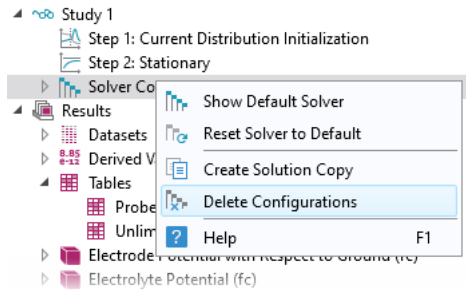

## Evaluating the Results

---

### *Compare the Polarization Curves*

Modify the Polarization Curve as follows to compare the concentration independent and concentration dependent solutions.

- 1 In the Model Builder window, expand the Polarization Curve node, then click Probe Table Graph 1.
- 2 In the Settings window for Table Graph, type Probe Table Graph: Limited O<sub>2</sub> gas phase transport in the Label text field.

- 3 Click to expand the Legends section. From the Legends list, choose Manual.
- 4 In the table, enter the following settings:

---

LEGENDS

---

Limited O2 gas phase transport

---

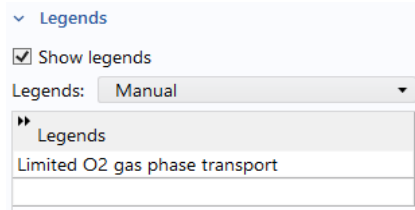

- 5 Right-click Probe Table Graph: Limited O2 gas phase transport and choose Duplicate.

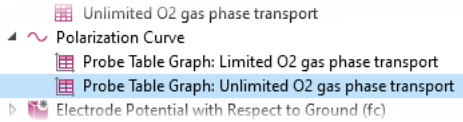

- 6 In the Settings window for Table Graph, type Probe Table Graph: Unlimited O2 gas phase transport in the Label text field.

- 7 Locate the Data section. From the Table list, choose

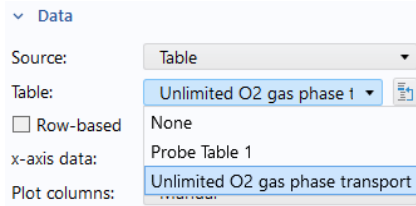

- 8 Locate the Legends section. In the table, enter the following settings:

---

LEGENDS

---

Unlimited O2 gas phase transport

---

- In the Model Builder window, click Polarization Curve, and in the Polarization Curve toolbar, click  Plot.

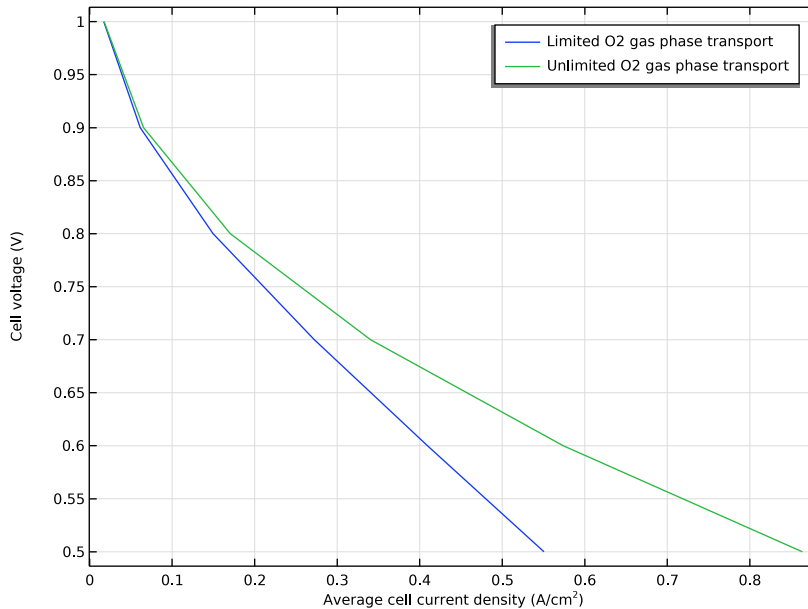

### Mole Fraction, O<sub>2</sub>, Streamline

The mole fractions of the different species are plotted by default at the cell potential of 0.5 V. Modify the O<sub>2</sub> plots as follows to plot at the cell potential of 0.7 V.

- In the Model Builder window, click Mole Fraction, O<sub>2</sub>, Streamline (fc).
- In the Settings window for 3D Plot Group, locate the Data section.

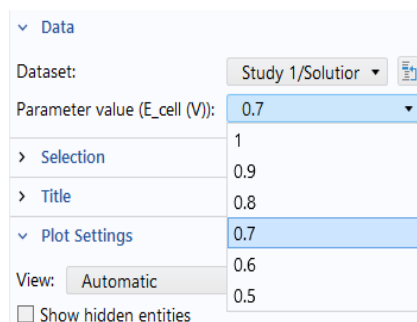

3 From the Parameter value ( $E_{\text{cell}}$  (V)) list, choose 0.7.

$E_{\text{cell}}(4)=0.7$  V    Species O2: Streamline: Total flux    Streamline Color: Mole fraction (1)

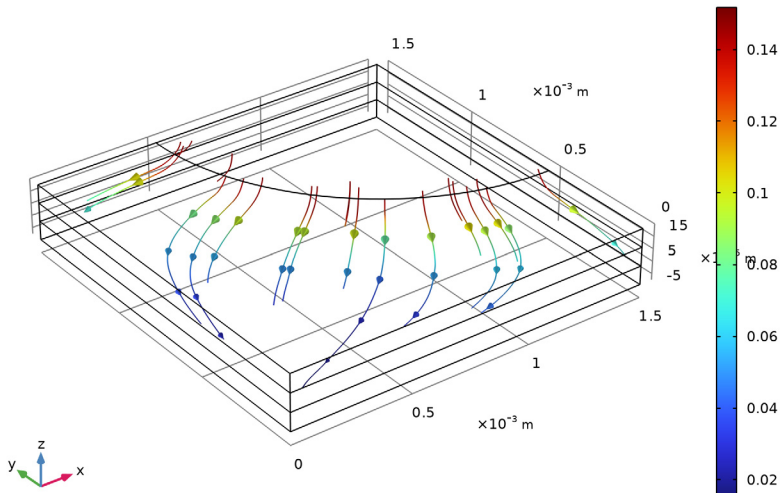

Note the direction of the arrows. Oxygen flows from the inlet hole into the porous cathode to react to form water.

#### *Mole Fraction, O<sub>2</sub>, Surface*

- 1 In the Model Builder window, click Mole Fraction, O<sub>2</sub>, Surface (fc).
- 2 In the Settings window for 3D Plot Group, locate the Data section.

3 From the Parameter value ( $E_{\text{cell}}$  (V)) list, choose 0.7.

$E_{\text{cell}}(4)=0.7$  V

Species O2: Mole fraction (1)

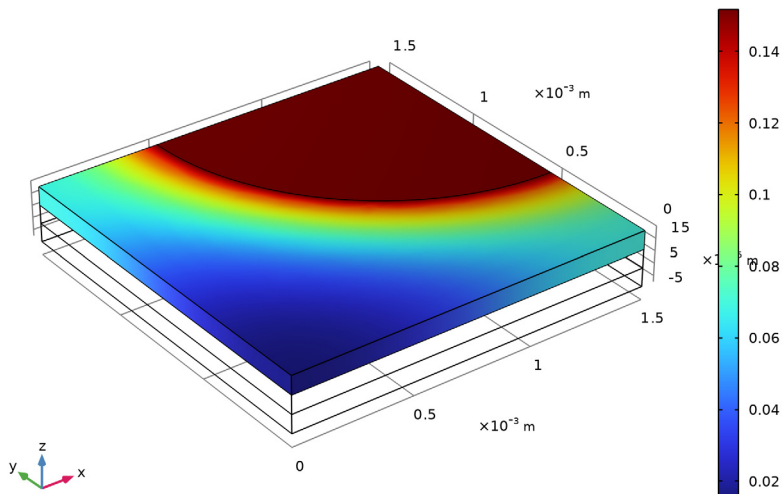

The oxygen mole fraction gets low far away from the inlet hole.

### Pressure

The Darcy pressure with velocity streamlines is also plotted by default at the cell potential of 0.5 V. Modify as follows to plot at the cell potential of 0.7 V.

- 1 In the Model Builder window, click Pressure (fc).
- 2 In the Settings window for 3D Plot Group, locate the Data section.

3 From the Parameter value ( $E_{\text{cell}}$  (V)) list, choose 0.7. Click Plot.

$E_{\text{cell}}(4)=0.7$  V

Multislice: Pressure (Pa) Streamline: Velocity field

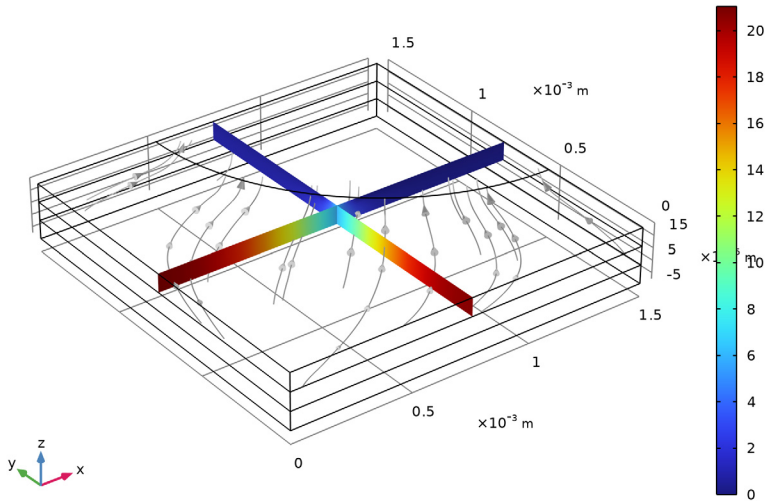

The direction of the net velocity is toward the inlet hole, that is, opposite to the oxygen flux. This is a result of the production of two water molecules per consumed oxygen molecule in the cathode.

### *Overpotential in Cathode*

Finally, create some additional plots for the activation overpotential and local volumetric current density in the cathode gas diffusion electrode, and the current density at the anode gas diffusion electrode boundary.

- 1 In the Home toolbar, click  Add Plot Group and choose 3D Plot Group.
- 2 In the Settings window for 3D Plot Group, type *Overpotential* in Cathode in the Label text field.
- 3 Locate the Data section. From the Parameter value ( $E_{\text{cell}}$  (V)) list, choose 0.7.

Now add a Surface Plot as follows:

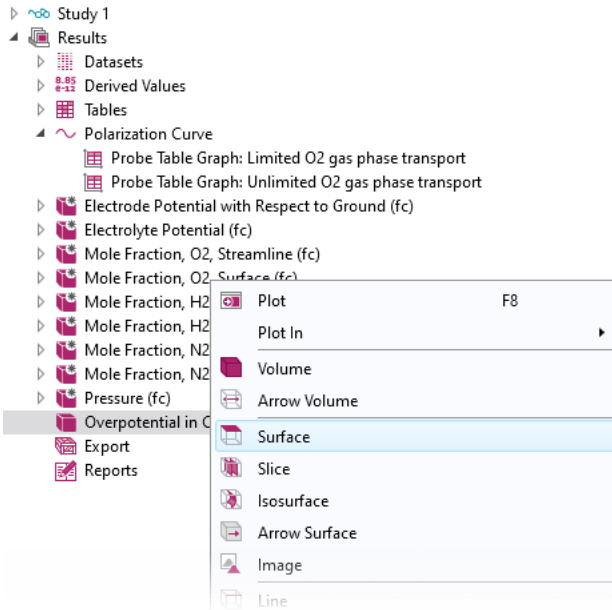

- 1 Right-click Overpotential in Cathode and choose Surface.
- 2 In the Settings window for Surface, click Replace Expression in the upper-right corner of the Expression section. From the menu, choose Component 1 (comp1) > Hydrogen Fuel Cell > Electrode kinetics > fc.eta\_o2gder1 - Overpotential - V.

- In the Overpotential in Cathode toolbar, click  Plot.

$E_{\text{cell}(4)}=0.7 \text{ V}$

Overpotential (V)

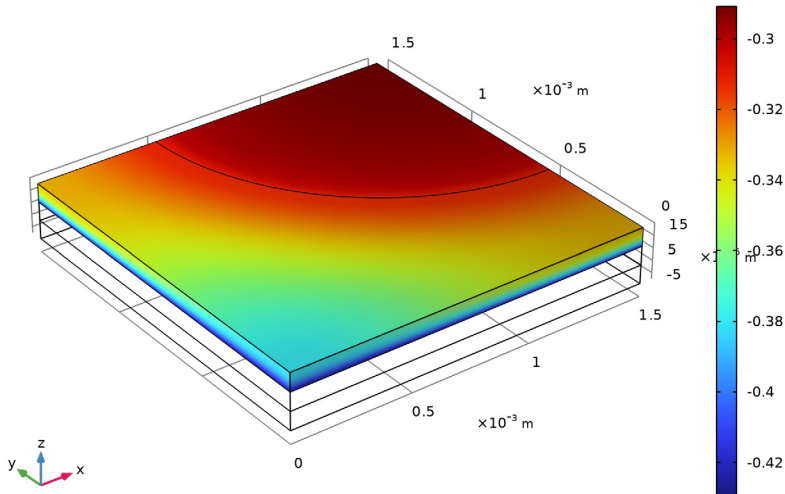

Generally, the highest overpotentials (in magnitude) are found in the region facing the Membrane domain. Since the overpotential is the driving force for the electrochemical reactions, this is the region where we can expect higher reaction rates.

### Local Volumetric Current Density in Cathode

- In the **Home** toolbar, click  **Add Plot Group** and choose **3D Plot Group**.
- In the **Settings** window for **3D Plot Group**, type Local Volumetric Current Density in Cathode in the **Label** text field.
- Locate the **Data** section. From the **Parameter value (E<sub>cell</sub> (V))** list, choose **0.7**.

Also here add a Surface plot as follows:

- Right-click Local Volumetric Current Density in Cathode and choose **Surface**.
- In the **Settings** window for **Surface**, click **Replace Expression** in the upper-right corner of the **Expression** section. From the menu, choose **Component 1 (comp1) > Hydrogen Fuel Cell > Electrode kinetics > fc.iv\_o2gder1 - Local current source - A/m<sup>3</sup>**.

3 In the Local Volumetric Current Density in Cathode toolbar, click  Plot.

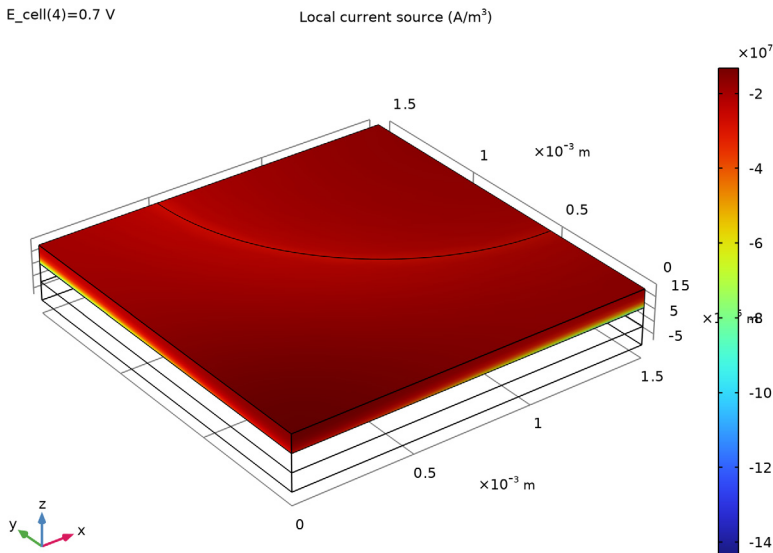

As for the overpotentials, the highest current density magnitudes are found close to the Membrane domain.

#### *Current Density at Anode Boundary*

- 1 In the Home toolbar, click  Add Plot Group and choose 3D Plot Group.
- 2 In the Settings window for 3D Plot Group, type Current Density at Anode Boundary in the Label text field.
- 3 Locate the Data section. From the Parameter value ( $E_{\text{cell}} \text{ (V)}$ ) list, choose 0.7.

Use a boundary selection to plot the current density at the anode boundary only.

- 1 Expand Selection section.
- 2 Select Boundary at the Geometry entity level.
- 3 Select Boundary 6 only.

Add a Surface plot as follows:

- 1 Right-click Current Density at Anode Boundary and choose Surface.
- 2 In the Settings window for Surface, click Replace Expression in the upper-right corner of the Expression section. From the menu, choose Component 1 (comp1) > Hydrogen Fuel Cell > fc.nll - Normal electrolyte current density -  $\text{A}/\text{m}^2$ .

- 3 Locate the Expression section. In the Expression text field, type  $\text{abs}(f_c.n11)$ . The  $\text{abs}()$  is an operator which will return the absolute (positive) value of the argument.
- 4 Select the Description checkbox.
- 5 In the associated text field, type Current density.
- 6 In the Current Density at Anode Boundary toolbar, click  Plot.

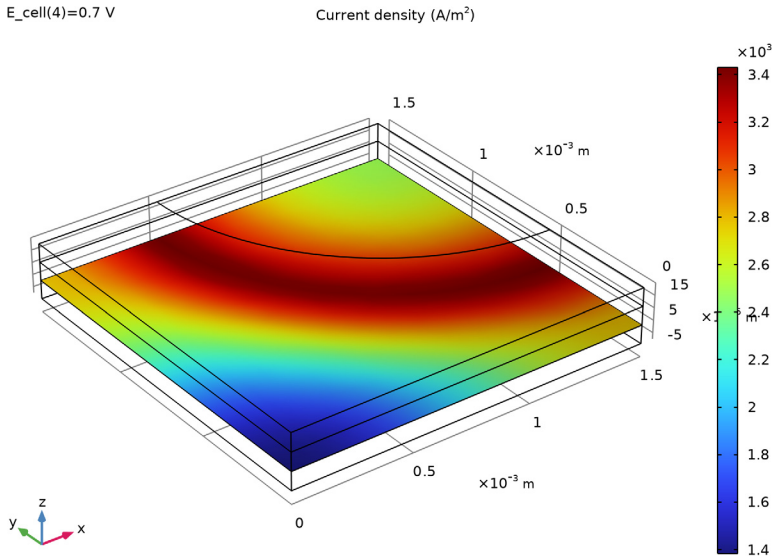

The region of the highest current densities is located below the quarter circular edge of the inlet hole. In this area the combined effects of the ohmic and mass transfer losses in the gas diffusion electrode are at a minimum.

### Power Losses

Finally, we will plot the different sources of power losses in the cell.

- 1 In the Home toolbar, click  Add Plot Group and choose 1D Plot Group.
- 2 In the Settings window for 1D Plot Group, type Power Losses in the Label text field.

Create a plot of a Global variable as follows:

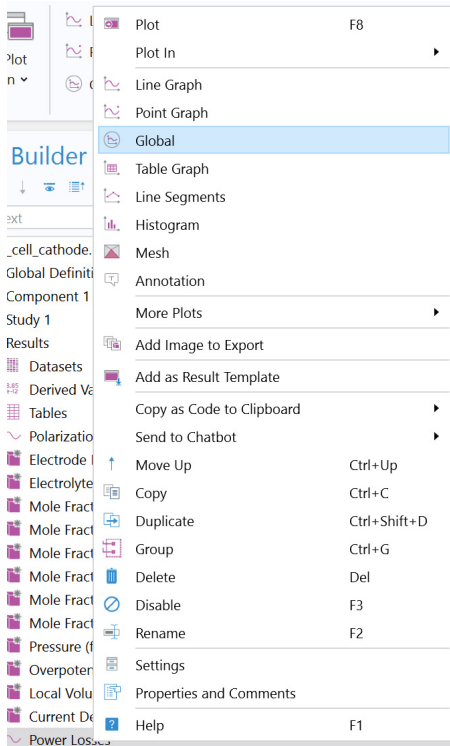

- 1 Right-click Power Losses and choose Global.
- 2 In the Settings window for Global, click Add Expression in the upper-right corner of the y-Axis Data section. From the menu, choose Component 1 (comp 1) > Hydrogen Fuel Cell > Power losses > Feature-node integrated > fc.o2gde1.o2gder1.P\_loss\_act - Kinetic activation power loss - W.
- 3 Click Add Expression in the upper-right corner of the y-Axis Data section. From the menu, choose Component 1 (comp 1) > Hydrogen Fuel Cell > Power losses > Cell integrated > fc.P\_loss\_1 - Electrolyte transport power loss - W.
- 4 Click Add Expression in the upper-right corner of the y-Axis Data section. From the menu, choose Component 1 (comp 1) > Hydrogen Fuel Cell > Cell integrated > fc.P\_loss\_s - Electron conduction power loss - W.
- 5 Click Add Expression in the upper-right corner of the y-Axis Data section. From the menu, choose Component 1 (comp 1) > Hydrogen Fuel Cell > Power losses > Cell integrated > fc.P\_loss\_gas - Gas transport power loss - W.

6 Click Add Expression in the upper-right corner of the y-Axis Data section. From the menu, choose Component 1 (comp 1) > Hydrogen Fuel Cell > Power losses > Feature-node integrated > fc.h2gde1.h2gder1.P\_loss\_act - Kinetic activation power loss - W.

7 Locate the y-Axis Data section. In the table, enter the following settings:

EXPRESSION	UNIT	DESCRIPTION
fc.o2gde1.o2gder1.P_loss_act	W	Kinetic activation, O2
fc.P_loss_1	W	Electrolyte transport
fc.P_loss_s	W	Electron conduction
fc.P_loss_gas	W	Gas transport
fc.h2gde1.h2gder1.P_loss_act	W	Kinetic activation, H2

8 Locate the x-Axis Data section. From the Parameter list, choose Expression.

9 In the Expression text field, type  $I_{avg}$ .

10 In the Unit field, type  $A/cm^2$ .

#### Power Losses

1 In the Model Builder window, click Power Losses.

2 In the Settings window for 1D Plot Group, locate the Plot Settings section.

3 Select the x-axis label checkbox. In the associated text field, type Average cell current density ( $A/cm^{sup>2</sup>}$ ).

4 Select the y-axis label checkbox. In the associated text field, type Power Loss (W).

5 Locate the Legend section. From the Position list, choose Upper left.

6 In the Power Losses toolbar, click  Plot.

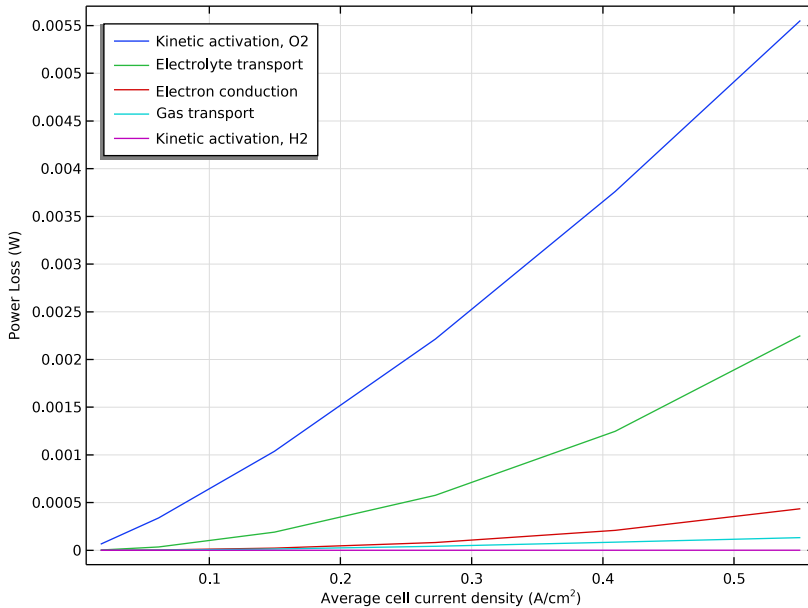

### Cell-Averaged Overpotentials

By dividing the integrated power losses of the cell by the cell current we can also compute corresponding overpotentials for the whole cell.

- 1 Right-click Power Losses and choose Duplicate.
- 2 In the Settings window for 1D Plot Group, type Cell-Averaged Overpotentials in the Label text field.

Modify the plot of a Global variable as follows:

- 1 In the Model Builder window, expand the Cell-Averaged Overpotentials node, then click Global 1.
- 2 In the Settings windows for Global, locate the y-Axis Data section.
- 3 In the table, enter the following settings:

EXPRESSION	UNIT	DESCRIPTION
$fc.o2gde1.o2gder1.P\_loss\_act / (I\_avg * A\_cell)$	V	Kinetic activation, O2
$fc.P\_loss\_l / (I\_avg * A\_cell)$	V	Electrolyte transport
$fc.P\_loss\_s / (I\_avg * A\_cell)$	V	Electron conduction

EXPRESSION	UNIT	DESCRIPTION
$fc.P_{loss\_gas}/(I_{avg}*A_{cell})$	V	Gas transport
$fc.h2gde1.h2gder1.P_{loss\_act}/(I_{avg}*A_{cell})$	V	Kinetic activation, H2

### Cell-Averaged Overpotentials

- 1 In the Model Builder window, click Cell-Averaged Overpotentials.
- 2 In the Settings window for 1D Plot Group, locate the Plot Settings section.
- 3 In y-axis label text field, type Cell-averaged overpotential (V).
- 4 In the Cell-Averaged Overpotentials toolbar, click  Plot.

