

INTRODUCTION TO
Electrodeposition Module

Introduction to the Electrodeposition Module

© 1998–2025 COMSOL

Protected by patents listed on www.comsol.com/patents, or see Help > About COMSOL Multiphysics on the File menu in the COMSOL Desktop for less detailed lists of U.S. Patents that may apply. Patents pending.

This Documentation and the Programs described herein are furnished under the COMSOL Software License Agreement (www.comsol.com/sla) and may be used or copied only under the terms of the license agreement.

COMSOL, the COMSOL logo, COMSOL Multiphysics, COMSOL Desktop, COMSOL Compiler, COMSOL Server, and LiveLink are either registered trademarks or trademarks of COMSOL AB. All other trademarks are the property of their respective owners, and COMSOL AB and its subsidiaries and products are not affiliated with, endorsed by, sponsored by, or supported by those trademark owners. For a list of such trademark owners, see www.comsol.com/trademarks.

Version: COMSOL 6.4

Contact Information

Visit the Contact COMSOL page at www.comsol.com/contact to submit general inquiries or search for an address and phone number. You can also visit the Worldwide Sales Offices page at www.comsol.com/contact/offices for address and contact information.

If you need to contact Support, an online request form is located on the COMSOL Access page at www.comsol.com/support/case. Useful links:

- Support Center: www.comsol.com/support
- Product Download: www.comsol.com/product-download
- Product Updates: www.comsol.com/product-update
- COMSOL Blog: www.comsol.com/blogs
- Discussion Forum: www.comsol.com/forum
- Events: www.comsol.com/events
- COMSOL Video Gallery: www.comsol.com/videos
- Support Knowledge Base: www.comsol.com/support/knowledgebase
- Learning Center: www.comsol.com/support/learning-center

Part number: CM022502

Contents

Introduction	5
The Electrodeposition Module Physics Interfaces	7
Physics Interface Guide by Space Dimension and Study Type ...	11
Tutorial — Decorative Plating	15
Model Definition	15
Results	17
Tutorial — Copper Deposition in a Trench	29
Model Definition	29
Results and Discussion	32
Reference	34

Introduction

Modeling and simulations are cost-effective ways to understand, optimize, and control electrodeposition processes.

The Electrodeposition Module is intended to investigate the influence of different parameters in an electrodeposition cell or on the thickness and composition of deposited layers. Important parameters that can be studied with the module include the following:

- Cell geometry
- Electrolyte composition and mixing
- Electrode kinetics
- Operating potential and average current density
- Temperature

A typical simulation yields the current distribution in the electrodeposition cell and at the surface of the electrodes. Faraday's law and the properties of the deposited material give them the thickness and composition of the deposited layer. This module is able to model cells both when the deposited thickness is negligible in comparison to the interelectrode gap and where the growth and dissolution of the electrodes have to be taken into account using moving boundaries.

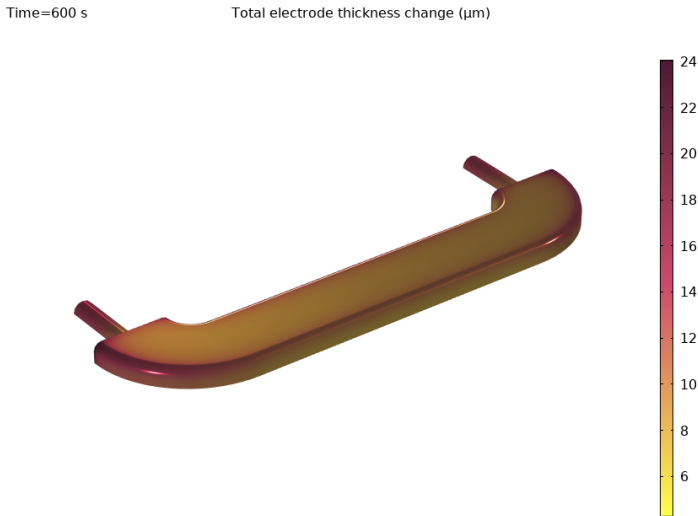

Figure 1: Thickness of the decorative deposited layer in a furniture fitting modeled using simulations based on secondary current distribution.

The targeted applications for the Electrodeposition Module include the following:

- Copper deposition for electronics and electrical applications
- Metal deposition for protection of parts, such as corrosion protection and protection against wear
- Decoration of metals and plastic parts
- Electroforming of parts with thin and complex structure
- Metal electrowinning

The next section introduces you to the available physics interfaces for this module and provides a brief overview of their use. It also includes a table listing the physics interfaces by space dimension and preset study type.

The rest of the introduction includes two tutorials. The first is a secondary current distribution model (secondary here means that we are including ohmic drops and activation overpotentials, but neglecting mass transport effects) where the thickness of the deposited layer can be neglected in the simulation and it therefore uses a fixed geometry. Go to the [Tutorial — Decorative Plating](#) to get started with this example.

The second model is a full tertiary current density distribution model (tertiary here means that we include ohmic drops, activation potentials and mass transport) that also accounts for the changes in the shapes of the cathode and anode surfaces using moving boundaries. Go to the [Tutorial — Copper Deposition in a Trench](#) to start working with this model.

The Electrodeposition Module Physics Interfaces

The module has a number of physics interfaces, which describe different phenomena in the electrolyte and at the electrodes in electrodeposition cells. A number of examples exemplify the use of these physics interfaces, which are based on the conservation of current, charge, chemical species, and energy. [Figure 2](#) shows the available physics interfaces in the Electrochemistry branch as displayed in the Model Wizard for a 3D model.

























- >  Chemical Species Transport
- ▼  Electrochemistry
 - ▼  Primary and Secondary Current Distribution
 -  Primary Current Distribution (cd)
 -  Secondary Current Distribution (cd)
 - ▼  Tertiary Current Distribution, Nernst-Planck
 -  Tertiary, Electroneutrality (tcd)
 -  Tertiary, Water-Based with Electroneutrality (tcd)
 -  Tertiary, Supporting Electrolyte (tcd)
 -  Tertiary, Poisson (tcd)
 -  Electroanalysis (tcd)
 -  Aqueous Electrolyte Transport (aqt)
 -  Concentrated Electrolyte Transport (cet)
 - ▼  Electrodeposition, Deformed Geometry
 -  Electrodeposition, Primary
 -  Electrodeposition, Secondary
 -  Electrodeposition, Tertiary with Electroneutrality
 -  Electrodeposition, Tertiary with Supporting Electrolyte
- >  Fluid Flow
- >  Heat Transfer

Figure 2: The 3D physics interfaces for the Electrodeposition Module, as shown in the Model Wizard, with the Electrochemistry branch fully expanded.

THE CURRENT DISTRIBUTION INTERFACES

The Electrochemistry interfaces include the Primary Current Distribution () , Secondary Current Distribution () , and Tertiary Current Distribution, Nernst Planck () interfaces. These are generic physics interfaces that can be used to model most kinds of electrochemical cells.

These interfaces include functionality to model the current distribution in the electrolyte as well as the deposition and thickness evolution of thin layers on the electrode surfaces. However, if the thickness of the deposited layer is of the same order of magnitude (or one order lower) compared to the geometrical details of the electrodes, then one of the Electrodeposition, Deformed Geometry () interfaces may have to be used instead. These interfaces are described in the next section.

The Primary Current Distribution () interface assumes a perfectly mixed electrolyte and neglects the activation losses for the charge transfer reactions. It should only be used for fast kinetics, where the activation losses are substantially smaller than the ohmic losses. The assumption of a perfectly mixed electrolyte implies that the electrolyte conductivity is not affected by the magnitude of the currents.

In the Secondary Current Distribution () interface the activation overpotential for the electrochemical reactions is taken into account.

The Primary and Secondary Current Distribution interfaces may be combined with a Chemical Species Transport interface (described below) in order to incorporate kinetic effects of active species in the electrolyte or adsorbed species on an electrode surface.

The Current Distribution, Boundary Elements () interface can be used for solving primary and secondary current distribution problems on geometries based on edge (beam or wire) and surface elements. The interface uses a boundary element method (BEM) formulation to solve for the charge transfer equation in an electrolyte of constant conductivity, where the electrodes are specified on boundaries or as tubes with a given radius around the edges. You typically use this interface in order to reduce the meshing and solution time for large geometries where a significant part of the geometry can be approximated as tubes along edges.

The Tertiary Current Distribution, Nernst-Planck () interface accounts for the transport of species through diffusion, migration, and convection. It is therefore able to describe the effects of variations in domain composition on the electrochemical processes. The kinetic expressions for the electrochemical reactions account for both activation and concentration overpotential.

The Aqueous Electrolyte Transport () interface computes the potential and species concentration fields in a dilute aqueous electrolyte. The interface targets modeling of aqueous electrolytes featuring weak acids, weak bases, ampholytes, and generic complex species. This includes, but is not limited to, electrochemical systems and phenomena containing multiple homogeneous reactions coupled to electrode kinetics. The transport is defined by the Nernst-Planck equations in combination with electroneutrality and water autoprotolysis.

The Concentrated Electrolyte Transport interface () is a generic interface for defining electrolyte transport. The electrolyte transport model is based on concentrated solution theory and can be applied to any type of electrochemical cell for an arbitrary number of electrolyte species. In contrast to the Tertiary Current Distribution, Nernst-Planck interfaces, the Concentrated Electrolyte Transport interface does not assume the presence of a neutral solvent, or a supporting electrolyte, of constant concentration.

THE ELECTRODEPOSITION, DEFORMED GEOMETRY INTERFACES

The Electrodeposition, Deformed Geometry () interfaces combine primary, secondary, and tertiary current distributions with a Deformed Geometry interface to keep track of the geometrical changes caused by deposition or dissolution reactions on an electrode surface. The interfaces are exemplified in [Figure 3](#). However, in the case where the thickness of the deposited layer at the surface of the cathode is negligible for the current distribution in the cell, a generic current distribution interface may also be used, as described in the previous section.

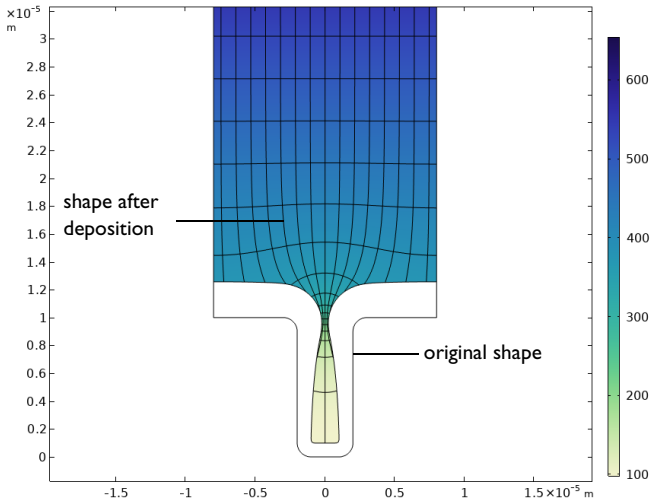



Figure 3: An example figure from the Copper Deposition in a Trench tutorial. The solid line shows the original shape of the cathode surface and the deformed field shows the shape of the surface after 10 s of deposition. The color table shows the copper ion concentration.

THE ELECTRODE SHELL INTERFACE

The Electrode, Shell interface () models electric current conduction in the tangential direction on a boundary. The physics interface is suitable to use for thin electrodes where the potential variation in the normal direction to the electrode is negligible. This assumption allows for the thin electrode domain to be replaced by a partial differential equation formulation on the boundary. In this way the problem size can be reduced, and potential problems with mesh anisotropy in the thin layer can be avoided.



THE ELECTROANALYSIS INTERFACE

The Electroanalysis interface () models mass transport of diluted species in electrolytes using the diffusion-convection equation, solving for electroactive species concentration(s). The physics interface is applicable for electrolyte

solutions containing a large quantity of inert “supporting” electrolyte. Ohmic losses are assumed to be negligible. The physics interface includes tailor-made functionality for setting up cyclic voltammetry problems.

THE CHEMICAL SPECIES TRANSPORT INTERFACES

The Surface Reactions interface () found in Chemical Species Transport can be set up to model adsorbed species on an electrode surface.

The Transport of Diluted Species interface () is available under the Chemical Species Transport Branch. In combination with the Secondary Current Distribution interface (), this physics interface can be used to model systems with supporting electrolytes. In these systems, the ions that give the largest contribution to the conduction of current are assumed to be present in uniform concentrations.

The Nernst-Planck-Poisson Equations () interface can be used for investigation of charge and ion distributions within the electrochemical double layer where charge neutrality cannot be assumed. A requisite when using this interface is that the double layer, which typically is in the range of tens nanometers, is fully resolved in the mesh. The equations solved for are identical to the Electrochemistry>Tertiary Current Distribution, Poisson interface.

The Transport of Diluted Species in Porous Media interface () is also available and describes species transport between the fluid, solid, and gas phases in saturated and variably saturated porous media. It applies to one or more species that move primarily within a fluid filling (saturated) or partially filling (unsaturated) the voids in a solid porous medium. The pore space not filled with fluid contains an immobile gas phase. Using these, models including a combination of porous media types can be studied.

The Electrophoretic Transport () interface can be used to investigate the transport of weak acids, bases, and ampholytes in aqueous solvents. The physics interface is typically used to model various electrophoresis modes, such as zone electrophoresis, isotachopheresis, isoelectric focusing, and moving boundary electrophoresis, but is applicable to any aqueous system involving multiple acid-base equilibria.

The Surface Reactions interface () can be used model reactions and translateral transport of surface (adsorbed) species.

The Chemistry interface () can be used to define systems of reacting species, electrode reactions and ordinary chemical reactions. As such, it serves as a reaction kinetics and material property provider to the space dependent transport interfaces, such as the Tertiary Current Distribution, Nernst-Planck interface, or Transport of Diluted Species interface.

OTHER PHYSICS INTERFACES

The Fluid Flow interfaces can be combined with the above interfaces to model free and forced convection in the electrolytic cell.







The Heat Transfer interfaces have ready-made formulations for the contribution of Joule heating, and other electrochemical losses, to the thermal balance in the cell.









The Level Set interface can be used in problems including deforming electrodes, subject to topological changes.

The detailed equations and assumptions that are defined by the physics interfaces are formulated in the *Electrodeposition Module User's Guide* and the *COMSOL Multiphysics Reference Manual*.









Physics Interface Guide by Space Dimension and Study Type

The table lists the physics interfaces available with this module in addition to those included with the COMSOL Multiphysics basic license.

PHYSICS INTERFACE	ICON	TAG	SPACE DIMENSION	AVAILABLE STUDY TYPE
 Chemical Species Transport				
Transport of Diluted Species		tds	all dimensions	stationary; time dependent
Chemistry		chem	all dimensions	stationary; time dependent
Nernst–Planck–Poisson Equations		tds+es	all dimensions	stationary; time dependent; stationary source sweep; small-signal analysis, frequency domain
Electrophoretic Transport		el	all dimensions	stationary; stationary with initialization; time dependent; time dependent with initialization
Transport of Diluted Species in Porous Media		tds	all dimensions	stationary; time dependent
Surface Reactions		sr	all dimensions	stationary (3D, 2D, and 2D axisymmetric models only); time dependent

PHYSICS INTERFACE	ICON	TAG	SPACE DIMENSION	AVAILABLE STUDY TYPE
 Reacting Flow				
Laminar Flow, Diluted Species		—	3D, 2D, 2D axisymmetric	stationary; time dependent
 Electrochemistry				
Primary Current Distribution		cd	all dimensions	stationary; stationary with initialization; time dependent; time dependent with initialization; AC impedance, initial values; AC impedance, stationary; AC impedance, time dependent
Secondary Current Distribution				
Tertiary Current Distribution, Nernst–Planck (Electroneutrality, Water-Based with Electroneutrality, Supporting Electrolyte, Poisson)		tcd	all dimensions	stationary; stationary with initialization; time dependent; time dependent with initialization; AC impedance, initial values; AC impedance, stationary; AC impedance, time dependent
Aqueous Electrolyte Transport		aqt	all dimensions	stationary; stationary with initialization; time dependent; time dependent with initialization
Concentrated Electrolyte Transport		cet	all dimensions	stationary; stationary with initialization; time dependent; time dependent with initialization;
Current Distribution, Boundary Element		cdbem	3D, 2D	stationary; stationary with initialization; time dependent; time dependent with initialization; AC impedance, initial values; AC impedance, stationary; AC impedance, time dependent

PHYSICS INTERFACE	ICON	TAG	SPACE DIMENSION	AVAILABLE STUDY TYPE
Electroanalysis		tcd	all dimensions	stationary; time dependent; AC impedance, initial values; AC impedance, stationary; AC impedance, time dependent; cyclic voltammetry
Electrode, Shell		els	3D, 2D, 2D axisymmetric	stationary; time dependent
 Electrodeposition, Deformed Geometry				
Electrodeposition, Primary		cd + dg	all dimensions	stationary; time dependent; time dependent with initialization; AC impedance, initial values; AC impedance, stationary; AC impedance, time dependent
Electrodeposition, Secondary				
Electrodeposition, Tertiary with (Electroneutrality, Supporting Electrolyte)		tcd + dg	all dimensions	stationary; stationary with initialization; time dependent; time dependent with initialization; AC impedance, initial values; AC impedance, stationary; AC impedance, time dependent
 Fluid Flow				
 Porous Media and Subsurface Flow				
Brinkman Equations		br	3D, 2D, 2D axisymmetric	stationary; time dependent
Darcy's Law		dl	all dimensions	stationary; time dependent
Free and Porous Media Flow, Brinkman		fp	3D, 2D, 2D axisymmetric	stationary; time dependent
Free and Porous Media Flow, Darcy		—	3D, 2D, 2D axisymmetric	stationary; time dependent

PHYSICS INTERFACE	ICON	TAG	SPACE DIMENSION	AVAILABLE STUDY TYPE
 Nonisothermal Flow				
Brinkman Equations		—	3D, 2D, 2D axisymmetric	stationary; time dependent; stationary, one-way NITF; time dependent, one-way NITF
 Heat Transfer				
Heat Transfer in Porous Media		ht	all dimensions	stationary; time dependent
 Mathematics				
 Moving Interface				
Level Set		ls	all dimensions	time dependent with phase initialization
Phase Field in Fluids		pf	all dimensions	time dependent; time dependent with phase initialization

Tutorial — Decorative Plating

This electroplating model uses secondary current distribution with full Butler–Volmer kinetics for the metal deposition or dissolution reaction on the cathode and anode. A competing hydrogen evolution reaction is also present on the cathode. The thickness of the deposited layer at the cathode is computed as well as the current efficiency.

Model Definition

The model geometry is shown in [Figure 4](#). The anode is a planar dissolving anode. The cathode represents a furniture fitting that is to be decorated by metal plating.

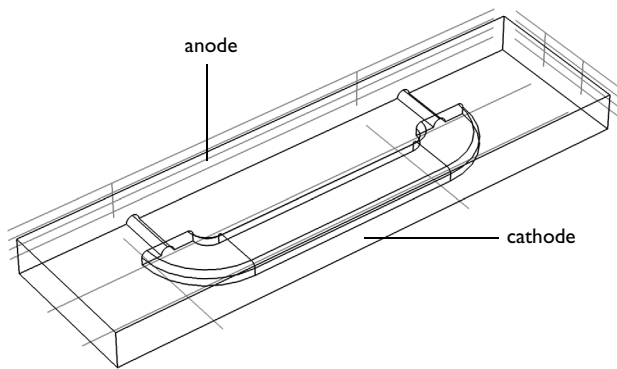

Figure 4: The model geometry.

The conductivity of the metal of the anode and cathode is very high compared to that of the electrolyte, and it is assumed that the electric potential in the metal is constant. The variations in the activation overpotential are therefore caused by the potential in the electrolyte at the surface of the electrodes. Under these assumptions, the electrodes are treated as boundaries in the simulations.

Before beginning, one difficulty found in all current density distribution models needs to be discussed.

The overpotential, η_m , for an electrode reaction of index m , is defined according to the following equation:

$$\eta_m = \phi_{s,0} - \phi_1 - E_{eq,m} \quad (1)$$

where $\phi_{s,0}$ denotes the electric potential of the metal, ϕ_l denotes the potential in the electrolyte, and $E_{eq,m}$ denotes the difference between the metal and electrolyte potentials at the electrode surface measured at equilibrium using a common reference potential. The electric potential of one of the electrodes may be bootstrapped, so that all other potentials are measured with this reference (this bootstrap can actually be achieved by fixing the potential at any point in the cell). In this case, the electric potential of the metal is selected at the cathode as a bootstrap by setting this potential to 0 V. This implies that the electric potential of the metal at the anode is equal to the cell voltage. The potential of the electrolyte floats and adapts to satisfy the balance of current, so that an equal amount of current that leaves at the cathode also enters at the anode. This then determines the overpotential at the anode and the cathode.

ELECTROLYTE CHARGE TRANSPORT

Use the Secondary Current Distribution interface to solve for the electrolyte potential, ϕ_l (V), assuming bulk electroneutrality:

$$\begin{aligned}\mathbf{i}_l &= -\sigma_l \nabla \phi_l \\ \nabla \cdot \mathbf{i}_l &= 0\end{aligned}\quad (2)$$

where \mathbf{i}_l (A/m²) is the electrolyte current density vector and σ_l (S/m) is the electrolyte conductivity, which is assumed to be a constant.

Use the default Insulation condition for all boundaries except the anode and cathode surfaces:

$$\mathbf{n} \cdot \mathbf{i}_l = 0 \quad (3)$$

where \mathbf{n} is the normal vector, pointing out of the domain.

The main electrode reaction on both the anode and the cathode surfaces is the nickel deposition/dissolution reaction according to



Using the Butler–Volmer equation to model this reaction will set the local current density to

$$i_{\text{loc, Ni}} = i_{0, \text{Ni}} \left(\exp\left(\frac{\alpha_a F \eta_{\text{Ni}}}{RT}\right) - \exp\left(-\frac{\alpha_c F \eta_{\text{Ni}}}{RT}\right) \right) \quad (5)$$

The rate of deposition at the cathode boundary surfaces and the rate of dissolution at the anode boundary surface, with a velocity in the normal direction, v (m/s), is calculated according to

$$v = \frac{i_{\text{loc, Ni}} M}{nF \rho} \quad (6)$$

where M is the mean molar mass (59 g/mol) and ρ is the density (8900 kg/m³) of the nickel atoms and n is number of participating electrons. It should be noted that the local current density is positive at the anode surface and it is negative at the cathode surfaces.

On the anode the electrolyte current density is set to the local current density of the nickel deposition reaction:

$$\mathbf{n} \cdot \mathbf{i}_l = i_{\text{loc, Ni}} \quad (7)$$

On the cathode, add a second electrode reaction to model the parasitic hydrogen evolution reaction:



Using cathodic Tafel equation to model the kinetics of the hydrogen reaction on the cathode will set the local current density to

$$i_{\text{loc, H}} = -i_{0, \text{H}} 10^{-\eta_{\text{H}}/A_c} \quad (9)$$

The hydrogen reaction will not contribute to the rate of deposition of nickel, but it will contribute to the total current density at the cathode surface:

$$\mathbf{n} \cdot \mathbf{i}_l = i_{\text{loc, Ni}} + i_{\text{loc, H}} \quad (10)$$

Solve the model in a time-dependent study, simulating the electroplating for 600 s.

Results

The figure below shows the thickness of the deposited layer after 600 s of deposition. The variations in thickness are relatively large, more than a factor of 5 between the thinnest and thickest parts. This suggests the need for an improvement of the cell geometry. Another alternative is to add surface active

species, also called levelers, that increase the kinetic losses at the electrode surfaces. These levelers help maintain a uniform current density.

Time=600 s

Total electrode thickness change (μm)

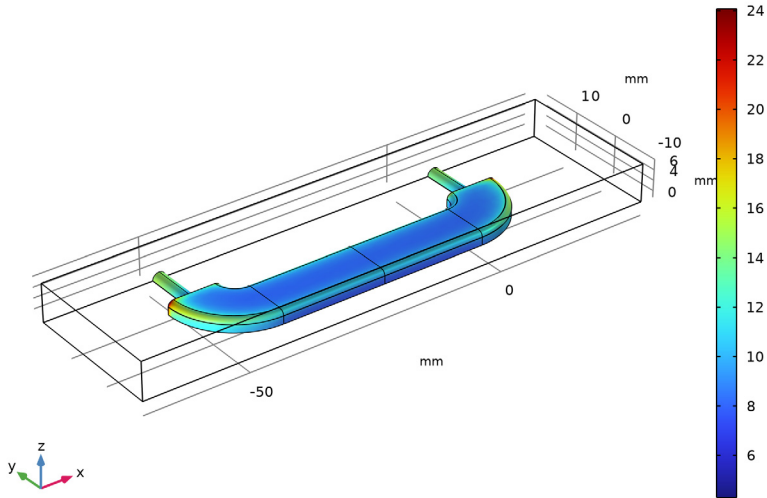

The second figure, shown below, depicts the local current efficiency over the cathode surface. The efficiency is calculated as the nickel deposition current density divided by the total current density at the cathode and is around 97%.

Time=600 s

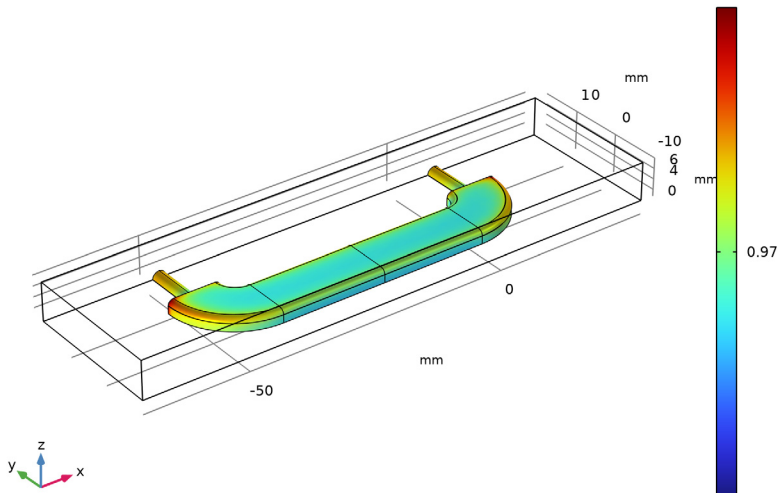

cd.iloc_er1/cd.itot (1)







Model Wizard

Note: These instructions are for the physics interface on Windows but apply, with minor differences, also to Linux and Mac.

- 1 To start the software, double-click the COMSOL icon on the desktop. When the software opens, you can choose to use the Model Wizard to create a new COMSOL Multiphysics model or Blank Model to create one manually. For this tutorial, click the Model Wizard button.

If COMSOL Multiphysics is already open, you can start the Model Wizard by selecting New  from the File menu and then click Model Wizard .



The Model Wizard guides you through the first steps of setting up a model. The next window lets you select the dimension of the modeling space.

- 2 In the Space Dimension window click the 3D button .
- 3 In the Select Physics tree, select Electrochemistry > Primary and Secondary Current Distribution, click Secondary Current Distribution (cd) .
- 4 Click Add then click the Study  button.
- 5 In the tree under Preset Studies, click Time Dependent with Initialization .
- 6 Click Done .

Global Definitions

Load the parameter values to be used in the model from a parameter file.

Parameters

- 1 In the Home toolbar click Parameters  and select Parameters 1 .

Note: On Linux and Mac, the Home toolbar refers to the specific set of controls near the top of the Desktop.

- 2 In the Settings window locate the Parameters section.
- 3 Click Load from File .
- 4 Browse to the file `decorative_plating_parameters.txt` in the application library folder on your computer, `applications\Electrodeposition_Module\Tutorials`. Double-click to add or click Open.

Note: The location of the file used in this exercise varies based on the installation of COMSOL Multiphysics. For example, if the installation is on your hard drive, the file path might be similar to `C:\Program Files\COMSOL\COMSOL64\Multiphysics\applications\`.

The parameters are added to the table as in this figure:

Parameters

Name	Expression	Value	Description
Eeq_Ni	-0.26[V]	-0.26 V	Equilibrium potential, nickel reaction
Iavg	-5[A/dm ²]	-500 A/m ²	Average cathode current density
kappa	10[S/m]	10 S/m	Electrolyte conductivity
M_Ni	59[g/mole]	0.059 kg/mol	Molar mass, nickel
rho_Ni	8900[kg/m ³]	8900 kg/m ³	Density, nickel
i0_Ni	0.1[A/m ²]	0.1 A/m ²	Exchange current density, nickel reaction
i0_H	2e-5[A/m ²]	2E-5 A/m ²	Exchange current density, hydrogen reaction

Geometry I

The model geometry is available as a geometry sequence in a separate MPH file. Load it from file with the following steps.

1 In the Geometry toolbar, click Insert Sequence and choose Insert Sequence.

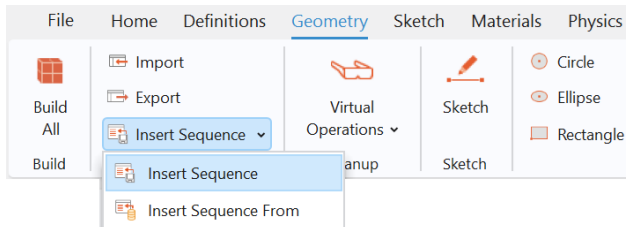

2 Browse to the file `decorative_plating_geom_sequence.mph` in the application library folder `Electrodeposition_Module\Tutorials`. Double-click to add or click Open.

Note: The location of the file used in this exercise varies based on your installation. For example, if the installation is on your hard drive, the file path might be similar to `C:\Program Files\COMSOL\COMSOL64\Multiphysics\applications\`.

3 Click the Build All button  .

The geometry displays in the Graphics window. Click the Wireframe Rendering button  in the Graphics toolbar to see inside the box and complete the next steps.

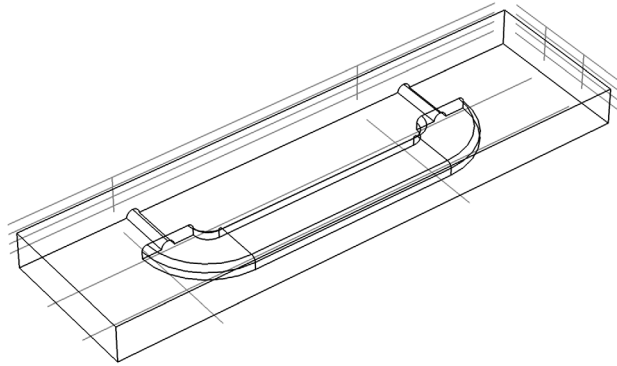

Secondary Current Distribution

Now start setting up the current distribution model, beginning with the settings for the electrolyte.

Define the Electrolyte Node

- In the Model Builder locate the Secondary Current Distribution node and then click Electrolyte 1 .

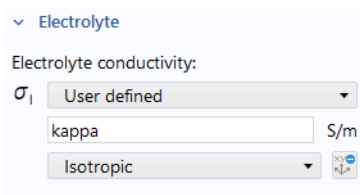
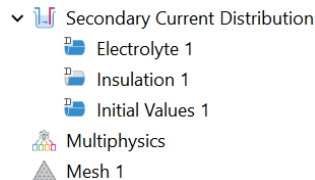



The ‘D’ in the upper left corner of a node means it is a default node.

- In the Settings window under Electrolyte, from the Electrolyte conductivity σ_1 list, select User defined. Enter kappa in the text field.

Define the Electrode Surface and the Electrode Reaction Node

Now define the cathode and the cathode electrode reaction. The combination of properties for the surface and the reaction stoichiometry will determine how the magnitude and direction of the growth velocity of the deposited layer relate to the electrode reaction currents.

- In the Physics toolbar click Boundaries  and choose Electrode Surface .

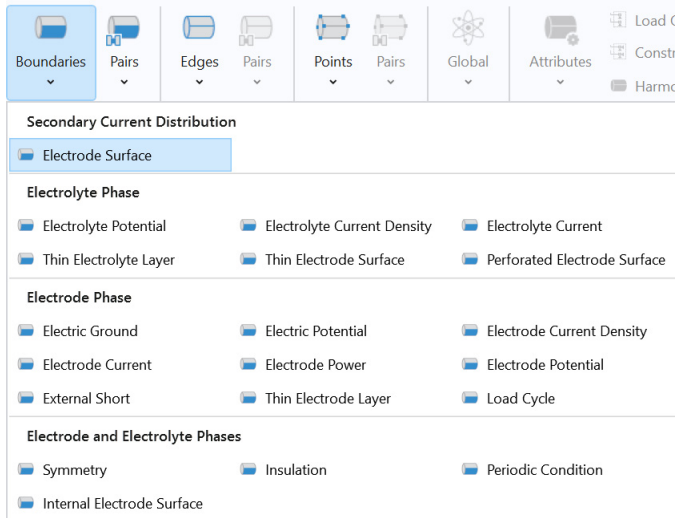

- In the Model Builder, under Secondary Current Distribution, click Electrode Surface 1 .

- Click the Paste Selection  button and enter 4.

- In the Settings window for Electrode Surface, click to expand the Dissolving-Depositing Species section.

- Click Add. In the table, type in Ni, ρ_{Ni} , and M_{Ni} in the Species, Density, and Molar mass columns, respectively. Select Solve for surface concentration variables.

▼ Dissolving-Depositing Species

Species	Density (kg/m ³)	Molar mass (kg/mol)
Ni	ρ_{Ni}	M_{Ni}

- Expand the Electrode Surface 1 node and click the Electrode Reaction 1 .

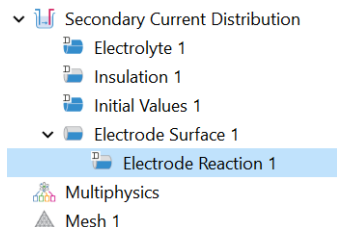

7 In the Settings window for Electrode Reaction under Stoichiometric Coefficients:

- In the Number of participating electrons n text field, enter 2.

8 Under Equilibrium Potential, in the Equilibrium potential E_{eq} text field, enter Eeq_Ni.

9 Under Electrode Kinetics from the Kinetics expression type list, select Butler–Volmer. In the Exchange current density i_0 text field, enter i0_Ni.

Define a Second Set of Electrode Surface and Electrode Reaction Nodes

Duplicate the cathode node to create the anode, and add the hydrogen reaction.

1 In the Model Builder window, right-click Component 1 (comp1) > Secondary Current Distribution (cd) > Electrode Surface 1 and choose Duplicate.

2 Locate the Boundary Selection section and select Cathode from the Selection list.

3 Under Electrode Phase Potential Condition select Average Current Density and type Iavg in the $i_{l, average}$ text field.

Electrode Phase Potential Condition

Electrode phase potential condition:

Average current density

$i_{l,average}$ Iavg A/m²

Stoichiometric Coefficients

Number of participating electrons:

n 2

Stoichiometric coefficients for dissolving-depositing species:

Species	Stoichiometric coefficient
Ni	1

$$\sum_{\nu_{ox} < 0} \nu_{ox} \text{Ox} + ne^- \rightleftharpoons \sum_{\nu_{red} > 0} \nu_{red} \text{Red}$$

Equilibrium Potential

Equilibrium potential:

E_{eq} User defined

Eeq_Ni V

Electrode Kinetics

Local current density expression:



$i_{loc,expr}$ From kinetics expression

Kinetics expression type:

Butler-Volmer

Exchange current density:

i_0 i0_Ni A/m²

4 Add the hydrogen evolution reaction. In the Model Builder under Secondary Current Distribution, right-click Electrode Surface 2  and choose Electrode Reaction .

5 In the Settings window for Electrode Reaction 2 locate the Stoichiometric Coefficients section. Set the Stoichiometric coefficient for Ni to 0.

6 In the Settings window for Electrode Reaction 2 locate the Electrode Kinetics section.

- From the Kinetics expression type list, choose Cathodic Tafel equation.
- In the i_0 text field, type i_{0_H} .

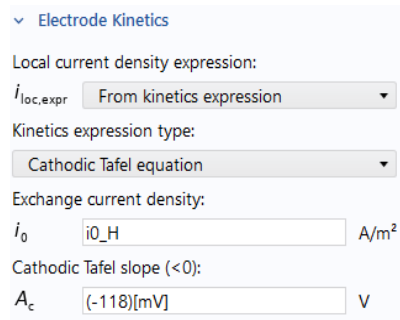
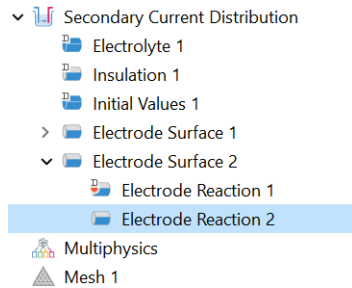

Mesh 1

1 In the Model Builder click the Mesh 1  node.



2 In the Settings window for Mesh from the Element size list, choose Fine.

3 Click the Build All button .

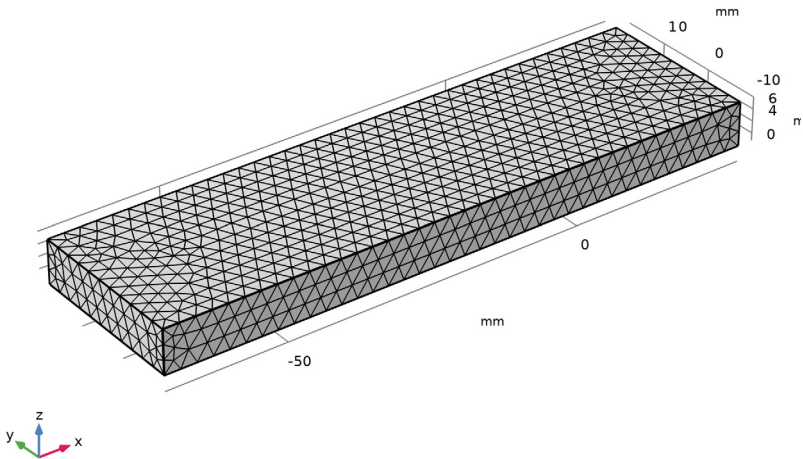















The mesh should match this figure.



Study 1

- 1 In the Model Builder expand the Study 1 node then click Step 2: Time Dependent .
- 2 In the Settings window under Study Settings and in the Times text field, enter range (0, 60, 600).
- 3 In the Home toolbar click Compute .

After a few moments, the default plots and Solver Configurations are added to the Model Builder and display in the Graphics window.

- ▼  Study 1
 -  Step 1: Current Distribution Initialization
 -  Step 2: Time Dependent
 - >  Solver Configurations
- ▼  Results
 - >  Datasets
 -  Derived Values
 -  Tables
 - >  Boundary Electrode Potential with Respect to Ground (cd)
 - >  Electrolyte Potential (cd)
 - >  Electrolyte Current Density (cd)
 - >  Electrode Potential with Respect to Ground (cd)
 - >  Electrode Potential with Respect to Adjacent Reference (cd)
 - >  Total Electrode Thickness Change (cd)
 -  Export
 -  Reports

Results

Modify One of the Default Plots

Modify the default plot for the electrode thickness change to show the deposited thickness on the cathode only.

- 1 Expand the Results > Total Electrode Thickness Change (cd) node.
- 2 Right-click Surface 1 and choose Selection.
- 3 In the Settings window for Selection, locate the Selection section.
- 4 From the Geometry entity level list, choose Boundary.
- 5 From the Selection list, choose Cathode.
- 6 On the Total Electrode Thickness Change (cd) toolbar, click Plot.
- 7 Click the Zoom Extents button in the Graphics toolbar.

The plot should match this figure.

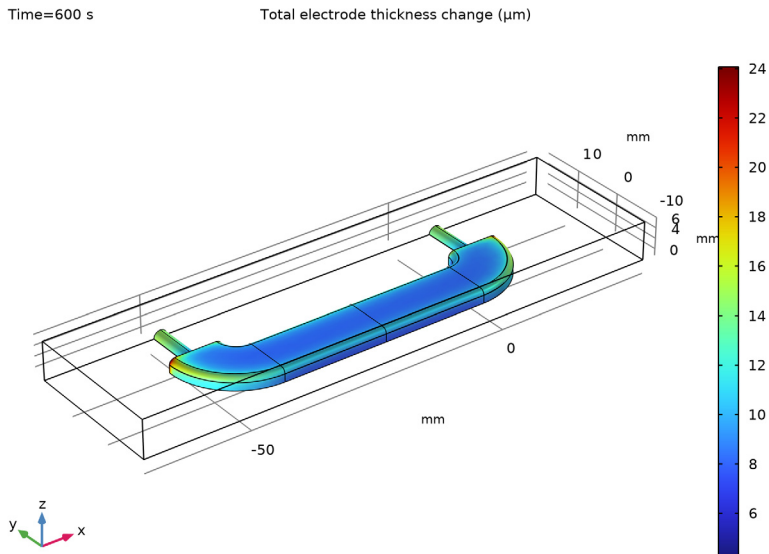

- 8 In the Model Builder window, under Results right-click the Total Electrode Thickness Change (cd) node and choose Rename.
- 9 In the Rename 3D Plot Group dialog, type Deposited Thickness, Cathode in the New label text field.
- 10 Click OK.

Create a current efficiency plot

- 1 Right-click Results > Deposited Thickness, Cathode and choose Duplicate.
- 2 In the Model Builder window, under Results right-click Deposited thickness, cathode 1 and choose Rename.
- 3 In the Rename 3D Plot Group dialog, type Current Efficiency, Cathode in the New label text field.
- 4 In the Model Builder window, expand the Deposited Thickness, Cathode 1 node, then click Surface 1.

- 5 Next, plot the current density of the nickel reaction divided with the total current density variable. First, locate the Expression section. In the Expression text field, type $cd.i_{loc_er1}/cd.itot$.

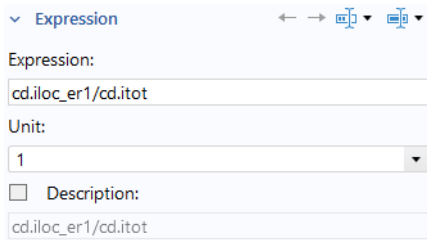

- 6 Click the Plot button .

The plot should match the figure.

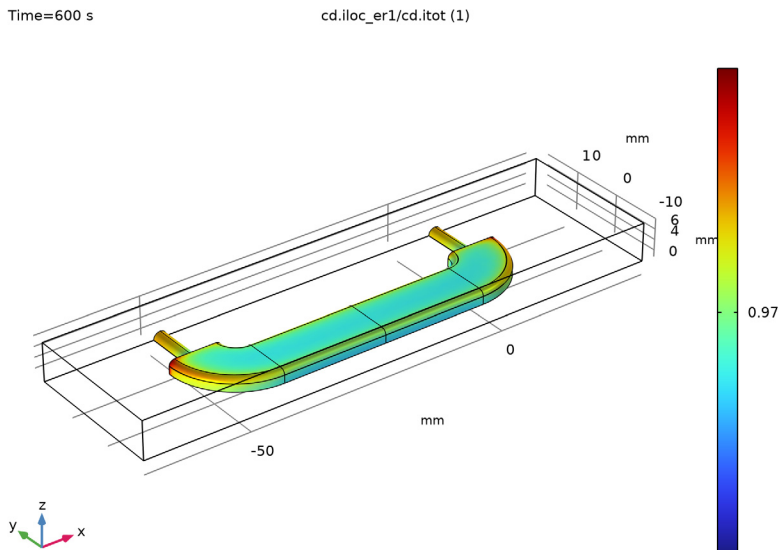

Tutorial — Copper Deposition in a Trench

This model simulates the electroplating of copper in a microcavity typically found in the plating of copper onto circuit boards. The plating cell is a laboratory cell under potentiostatic control where the anode is placed in close vicinity of the cathode. The model is based on the work by Mattsson and Bockris (Ref. 1).

The purpose of the model is to demonstrate the use of moving meshes for plating processes and to investigate the influence of the cavity on the plating result. The moving mesh makes it possible to simulate the growth of the cathode boundary as the process proceeds.

Model Definition

The model simulates the deposition process at pH 4, which implies that the proton concentration is very low compared to the copper and sulfate ion concentrations. For this reason, the material balance of the protons does not need to be modeled. Sulfate is also treated as a fully dissociated ion. The deposition at the cathode and the dissolution at the anode are assumed to take place with 100% current yield, which means that the model does not include possible side reactions. During the process, differences in electrolyte density arise in the enclosed cell, giving higher density at the anode compared to the cathode. This can induce free convection in the cell. Under the modeled conditions, however, the variations in composition are small and it is therefore possible to neglect free convection.

The process is inherently time-dependent because the cathode boundary moves as the deposition process takes place. The model is defined by the material balances for the involved ions — copper, Cu^{2+} , and sulfate, SO_4^{2-} — and the electroneutrality condition. This gives three unknowns and three model equations. The dependent variables are the copper ion, sulfate ion, and ionic potentials. Additional variables keep track of the deformation of the mesh.

The model geometry is shown in [Figure 5](#). The upper horizontal boundary represents the anode, while the cathode is placed at the bottom. The vertical walls

correspond to the pattern on the master electrode and are assumed to be insulating.

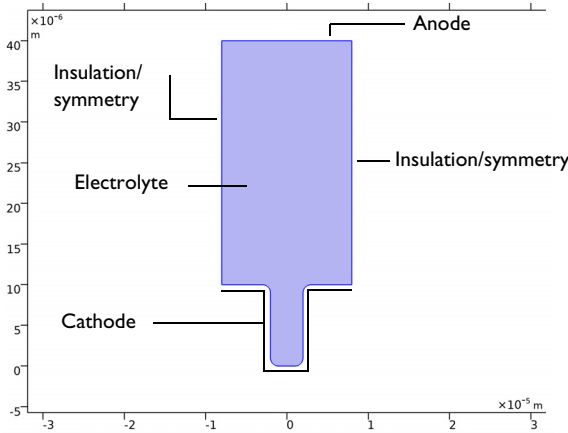

Figure 5: Model domain with boundaries corresponding to the anode, cathode, and vertical symmetry walls.

The flux for each of the ions in the electrolyte is given by the Nernst–Planck equation

$$\mathbf{J}_i = -D_i \nabla c_i - z_i u_i F c_i \nabla \phi_l \quad (11)$$

where \mathbf{J}_i denotes the transport vector ($\text{mol}/(\text{m}^2 \cdot \text{s})$), c_i the concentration in the electrolyte (mol/m^3), z_i the charge for the ionic species, u_i the mobility of the charged species ($\text{m}^2/(\text{s} \cdot \text{J} \cdot \text{mole})$), F Faraday’s constant ($\text{A} \cdot \text{s}/\text{mole}$), and ϕ_l the potential in the electrolyte (V). The material balances are expressed through

$$\frac{\partial c_i}{\partial t} + \nabla \cdot \mathbf{J}_i = 0 \quad (12)$$

one for each species, that is $i = 1, 2$. The electroneutrality condition is given by the following expression:

$$\sum_i z_i c_i = 0 \quad (13)$$

The boundary conditions for the anode and cathode are given by the Butler–Volmer equation for copper deposition. The deposition process is assumed to take place through the following simplified mechanism:



where the first step is rate determining step, RDS, and the second step is assumed to be at equilibrium (Ref. 1). This gives the following relation for the local current density as a function of potential and copper concentration:

$$i_{\text{ct}} = i_0 \left(\exp\left(\frac{1.5F\eta}{RT}\right) - \frac{c_{\text{Cu}^{2+}}}{c_{\text{Cu}^{2+},\text{ref}}} \exp\left(-\frac{0.5F\eta}{RT}\right) \right)\tag{15}$$

where η denotes the overpotential defined as

$$\eta = \phi_{\text{s},0} - \phi_1 - \Delta\phi_{\text{eq}}\tag{16}$$

where $\phi_{\text{s},0}$ denotes the electronic potential of the respective electrode. This gives the following condition for the cathode:

$$\begin{aligned}\mathbf{J}_{\text{Cu}^{2+}} \cdot \mathbf{n} &= -\frac{i_0}{2F} \left(\exp\left(\frac{1.5F(\phi_{\text{s},\text{cat}} - \phi_1 - \Delta\phi_{\text{eq}})}{RT}\right) \right. \\ &\quad \left. - \frac{c_{\text{Cu}^{2+}}}{c_{\text{Cu}^{2+},\text{ref}}} \exp\left(-\frac{0.5F(\phi_{\text{s},\text{cat}} - \phi_1 - \Delta\phi_{\text{eq}})}{RT}\right) \right)\end{aligned}\tag{17}$$

where \mathbf{n} denotes the normal vector to the boundary. The condition at the anode is

$$\begin{aligned}\mathbf{J}_{\text{Cu}^{2+}} \cdot \mathbf{n} &= -\frac{i_0}{2F} \left(\exp\left(\frac{1.5F(\phi_{\text{s},\text{an}} - \phi_1 - \Delta\phi_{\text{eq}})}{RT}\right) \right. \\ &\quad \left. - \frac{c_{\text{Cu}^{2+}}}{c_{\text{Cu}^{2+},\text{ref}}} \exp\left(-\frac{0.5F(\phi_{\text{s},\text{an}} - \phi_1 - \Delta\phi_{\text{eq}})}{RT}\right) \right)\end{aligned}\tag{18}$$

All other boundaries are insulating:

$$\mathbf{J}_{\text{Cu}^{2+}} \cdot \mathbf{n} = 0\tag{19}$$

For the sulfate ions, insulating conditions apply everywhere:

$$\mathbf{J}_{\text{SO}_4^{2-}} \cdot \mathbf{n} = 0\tag{20}$$

The initial conditions set the composition of the electrolyte according to

$$\begin{aligned}c_{\text{Cu}^{2+}} &= c_0 \\ c_{\text{SO}_4^{2-}} &= c_0\end{aligned}\tag{21}$$

You set up [Equation 11](#) through [Equation 21](#) using the Tertiary Current Distribution, Nernst–Planck interface. The Deformed Geometry interface keeps track of the deformation of the mesh.

Using the Electrode Surface boundary node, the ion fluxes and the boundary mesh velocity are based on the reaction currents, the number of electrons, and the specified stoichiometric coefficients of the electrode reactions. The sign of the stoichiometric coefficient for a species depends on whether the species is getting oxidized (positive) or reduced (negative) in the reaction. In the case for the total reaction in this model

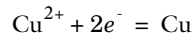

the stoichiometric coefficient is $v_{\text{Cu}^{2+}} = -1$ for the copper ions in the electrolyte, and $v_{\text{Cu}} = 1$ for the copper atoms in the electrodes.

Results and Discussion

[Figure 6](#) shows the concentration distribution of copper ions, the isopotential lines, the current density lines, and the displacement of the cathode and anode surfaces after 14 seconds of operation. The figure shows that the mouth of the cavity is narrower due to the nonuniform thickness of the deposition. This effect can be detrimental to the quality of the deposition because a trapped electrolyte can later cause corrosion of components in the circuit board. In addition, the simulation shows substantial variations in copper ion concentration in the cell. Such variations eventually cause free convection in the cell. The model is symmetric along a

vertical line in the middle of the cell. A nonsymmetric result is a sign of poor mesh resolution.

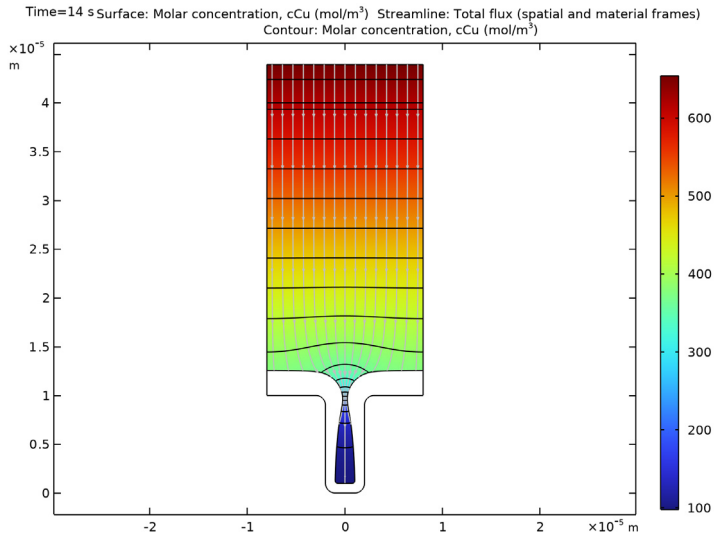

Figure 6: Copper ion concentration (mol/m^3), isopotential lines, current density streamlines, and electrode displacement in the cell after 14 seconds of operation.

Figure 7 shows the thickness of the deposition along one of the vertical cathodic surfaces. The lines reveal the development of the nonuniform deposition due to

nonuniform current density distribution. This effect is accentuated by the depletion of copper ions along the depth of the cavity.

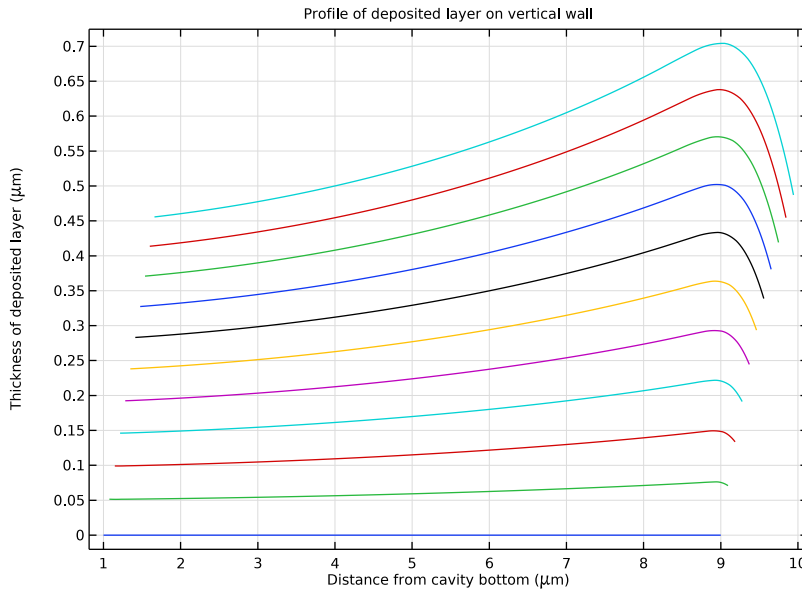





Figure 7: Thickness of the deposition along the vertical cathode boundaries. The lines are generated for increments of 0.5 seconds from 0 to 5 seconds.

Despite the simplicity of this model, it can easily be expanded to more complicated geometries or to include the influence of more ions on the process.

Reference

1. E. Mattsson and J.O'M. Bockris, "Galvanostatic Studies of the Kinetics of Deposition and Dissolution in the Copper + Copper Sulphate System," *Trans. Far. Soc.*, vol. 55, p. 1586, 1959.

Model Wizard

- 1 If COMSOL is already open, you can start the Model Wizard by selecting New  from the File menu and then click Model Wizard .
- 2 In the Space Dimension window click 2D .

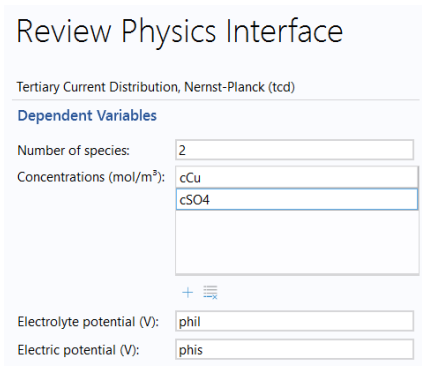

- 3 In the Select Physics tree under Electrochemistry > Electrodeposition, Deformed Geometry click Electrodeposition, Tertiary with Electroneutrality .
- 4 Click Add, then rename the two concentration dependent variables to cCu and cSO4.



- 5 Click the Study  button.
- 6 In the tree under Preset Studies click Time Dependent with Initialization .
- 7 Click Done .

Global Definitions — Parameters

Note: The location of the text file used in this exercise varies based on your installation. For example, if the installation is on your hard drive, the file path might be similar to C:\Program Files\COMSOL\COMSOL64\Multiphysics\applications\.

- 1 In the Home toolbar click Parameters  and select Parameters 1 .
- 2 In the Settings window locate the Parameters section. Click the Load from File  button.

- 3 Browse to the application library folder `Electrodeposition_Module\Tutorials` and double-click the file `cu_trench_deposition_parameters.txt`. The data is added to the table.



Parameters

Name	Expression	Value	Description
Cinit	500[mol/(m^3)]	500 mol/m ³	Initial concentration
T0	298[K]	298 K	System temperature
i0_ref	250[A/m^2]	250 A/m ²	Exchange current density for reference conditions
phis_anode	0.135[V]	0.135 V	Anode potential
phis_cathode	-0.135[V]	-0.135 V	Cathode potential
alpha_a	1.5[1]	1.5	Symmetry factor
z_Cu	2[1]	2	Charge, species Cu
z_SO4	-2[1]	-2	Charge, species SO4
D_Cu	2e-9[m^2/s]	2E-9 m ² /s	Diffusivity, species Cu
D_SO4	D_Cu	2E-9 m ² /s	Diffusivity, species SO4

Geometry 1

Draw the geometry by making a union of two rectangles. Round off the corners of the trench using fillets.

Add Two Rectangles

- 1 In the Model Builder under Component 1, right-click Geometry 1  and choose Rectangle .



2 In the Settings window for Rectangle under Size:

- In the Width text field enter $1.6e-5$
- In the Height text field enter $3e-5$

3 Under Position:

- In the x text field enter $-0.8e-5$
- In the y text field enter $1e-5$



Add another rectangle.

4 Right-click Geometry 1  and choose Rectangle .

5 In the Settings window for Rectangle under Size:

- In the Width text field, enter $0.4e-5$
- In the Height text field enter $1e-5$

6 Under Position, in the x text field enter $-0.2e-5$.



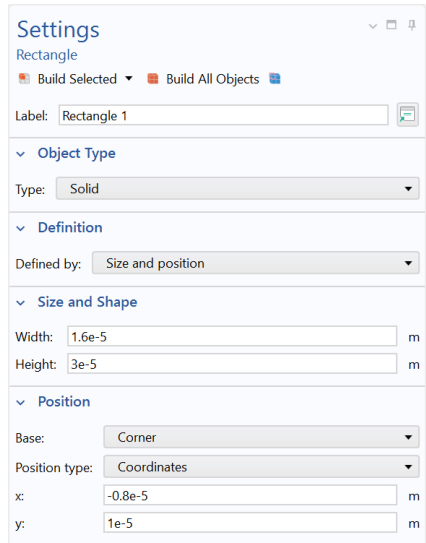

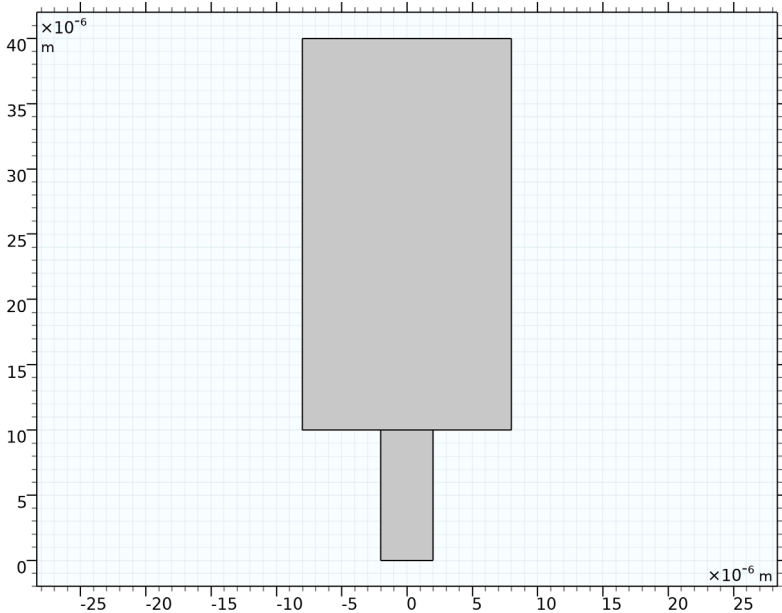

7 Click the Build Selected button  then click the Zoom Extents button  in the Graphics toolbar.



The geometry should match this figure:



Add a Union Node and a Fillet Node

- 1 In the Model Builder right-click Geometry 1  and choose Booleans and Partitions > Union .
- 2 In the Settings window under Union, click to clear the Keep interior boundaries checkbox. Then add the objects r1 and r2 to the Input objects section, for example, by clicking each rectangle in the Graphics window.
- 3 Click the Build Selected button .
- 4 To smooth the edges of the lower rectangle, add a Fillet  node. This can be done by Right-clicking Geometry 1  and choosing Fillet .
- 5 In the Graphics window for the object uni1, select Vertices 3–6 only (as shown in the figure).

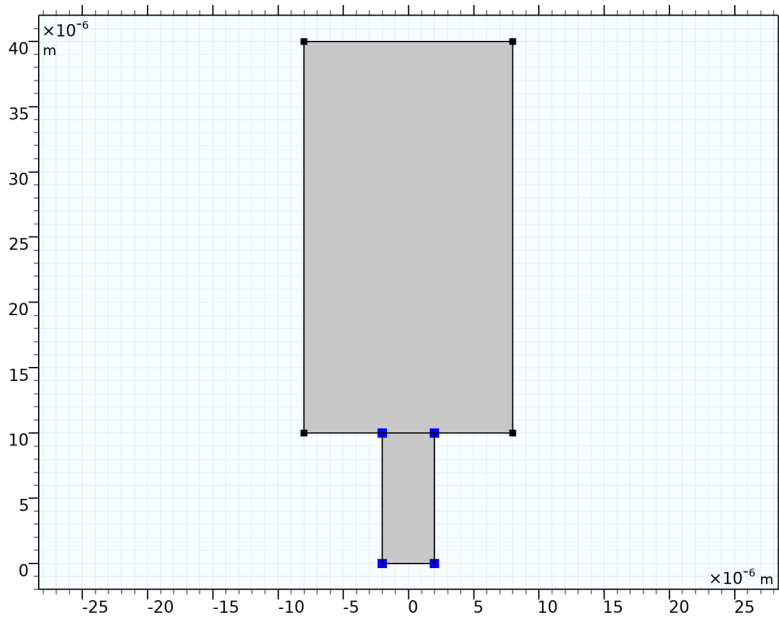

- 6 Confirm that 3, 4, 5, 6 are added to the Vertices to fillet list.

- 7 In the Settings window for Fillet under Radius, enter $1e-6$ in the Radius text field.

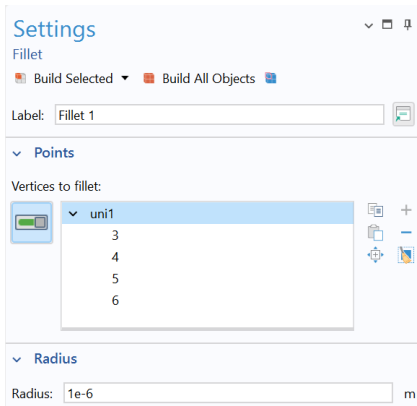

- 8 In the Model Builder, right-click the Form Union node and select Build Selected .

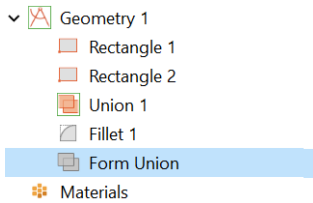

The final geometry should match the figure.

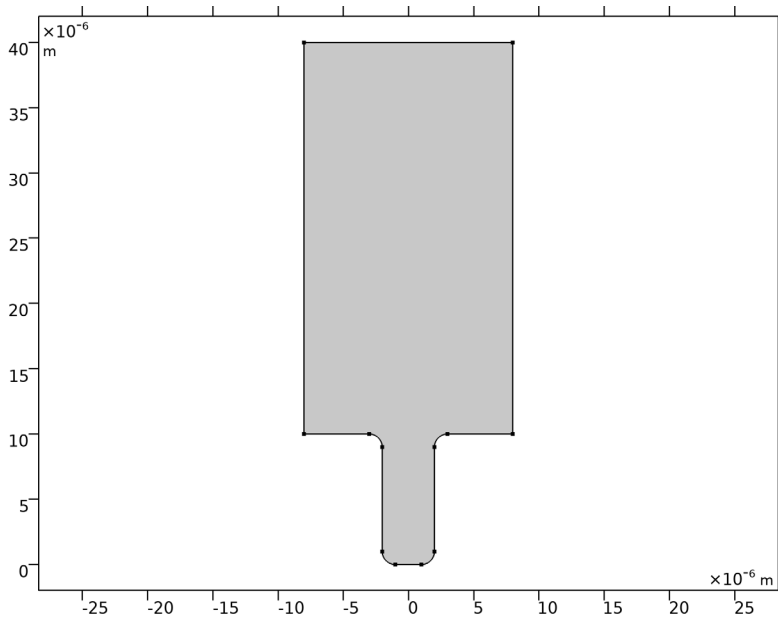

Tertiary Current Distribution, Nernst–Planck

Now set up the electrochemical model, which consists of an electrolyte domain and two electrode boundaries.

Define the Electrolyte Properties

- 1 In the Model Builder locate the Tertiary Current Distribution, Nernst–Planck node, then click Species Properties 1 .

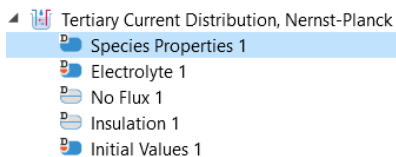

2 Under Charge, replace the defaults with the following:

Charge

z_{cCu} 1

z_{cSO4} 1

- In the z_{cCu} text field, enter z_Cu.
- In the z_{cSO4} text field, enter z_SO4.

3 Under the Tertiary Current Distribution, Nernst–Planck node, click Electrolyte 1

4 Under Diffusion, replace the defaults with the following:

- In the D_{cCu} text field, enter D_Cu.
- In the D_{cSO4} text field, enter D_SO4.

Diffusion

Material:

Diffusion coefficient: D_{cCu} m²/s

Diffusion coefficient: D_{cSO4} m²/s

Define the Electrode Surface and Electrode Reaction Nodes

1 In the Physics toolbar click Boundaries  and choose Electrode Surface .

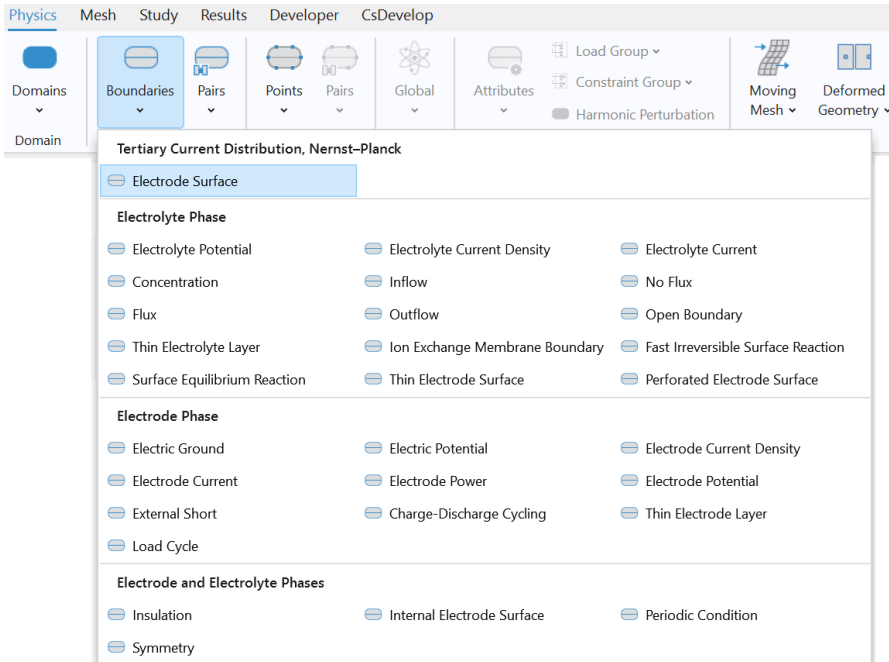

2 In the Settings window for Electrode Surface under Boundary Selection, from the Selection list select Boundary 3.

3 An easy way to facilitate choosing this electrode surface later is to create a selection here. To do so, click the Create Selection button  and type Anode in the Selection name text field of the Create Selection dialog that appears.

4 In the Settings window for Electrode Surface, click to expand the Dissolving-Depositing Species section.

5 Click Add.

6 Under Species in the Dissolving-Depositing Species table, enter `cdep_anode` (replace the default).









▼ Dissolving-Depositing Species

Species	Density (kg/m ³)	Molar mass (kg/mol)
cdep_anode	8960	0.06355

- 7 Under Electrode Phase Potential Condition in the $\phi_{s,\text{ext}}$ text field, enter phis_anode.

▼ Electrode Phase Potential Condition
 Electrode phase potential condition:
 Electric potential ▼
 External electric potential:
 $\phi_{s,\text{ext}}$ phis_anode V

- 8 Expand the Electrode Surface 1 node then click Electrode Reaction 1 .

▲  Tertiary Current Distribution, Nernst-Planck
 ▶  Species Properties 1
 ▶  Electrolyte 1
 ▶  No Flux 1
 ▶  Insulation 1
 ▶  Initial Values 1
 ▲  Electrode Surface 1
 ▶  Electrode Reaction 1

- 9 Under Stoichiometric Coefficients:

- In the Number of participating electrons n text field, enter 2.

- 10 Under Electrode Kinetics:

- From the Kinetics expression type list, choose Butler–Volmer.
- From the Exchange current density type list, choose Mass action law.
- In the Reference exchange current density $i_{0,\text{ref}}$ text field, enter i0_ref.
- In the Anodic transfer coefficient α_a text field, enter alpha_a.

▼ Electrode Kinetics
 Local current density expression:
 $i_{\text{loc,expr}}$ From kinetics expression ▼
 Kinetics expression type:
 Butler-Volmer ▼
 Exchange current density type:
 Mass action law ▼
 Reference exchange current density:
 $i_{0,\text{ref}}(T)$ i0_ref A/m²
 Anodic transfer coefficient:
 α_a alpha_a 1

Define the Second Electrode Surface and Electrode Reaction Nodes

Duplicate the anode node to create the settings for the cathode.

Define the Temperature

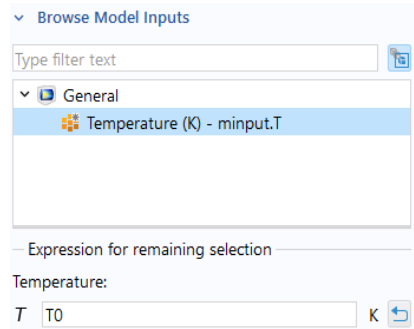
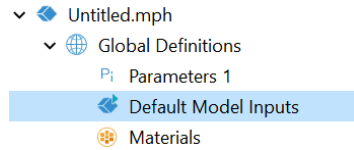

Set up the temperature value used in the entire model.

- 1 In the Model Builder window, under Global Definitions click Default Model Inputs and locate the Browse Model Inputs section.
- 1 In the tree, select General > Temperature (K) - minput.T.
- 2 Find the Expression for remaining selection subsection. In the Temperature text field, type T0.



Mesh

Now make the settings for the mesh. A finer mesh is necessary to properly resolve the electrodeposition process at the boundary. In addition, we need to change mesh settings to properly remesh the channel as it gets thinner and thinner during deposition.

- 1 In the Model Builder right-click Mesh 1  and choose Edit Physics-Induced Sequence .
- 2 Click the Size node  and in the Settings window click the Custom button.

3 Click the Size  node, and enter the following under the Element Size Parameters section:

- Maximum element size text field, enter $5e-7$. By choosing a small maximum element size, we ensure a resolution of at least $0.5\ \mu\text{m}$.
- Curvature factor text field enter 1. The curvature factor is the ratio between the element size and the radius of curvature of a boundary in the model. In other words, we here set that the maximum element size on a boundary should be the same as the curvature radius.
- Resolution of narrow regions text field enter 10. This ensures that approximately 10 layers of elements will always be used in narrow regions.

Element Size Parameters

Maximum element size: m

Minimum element size: m

Maximum element growth rate:

Curvature factor:

Resolution of narrow regions:

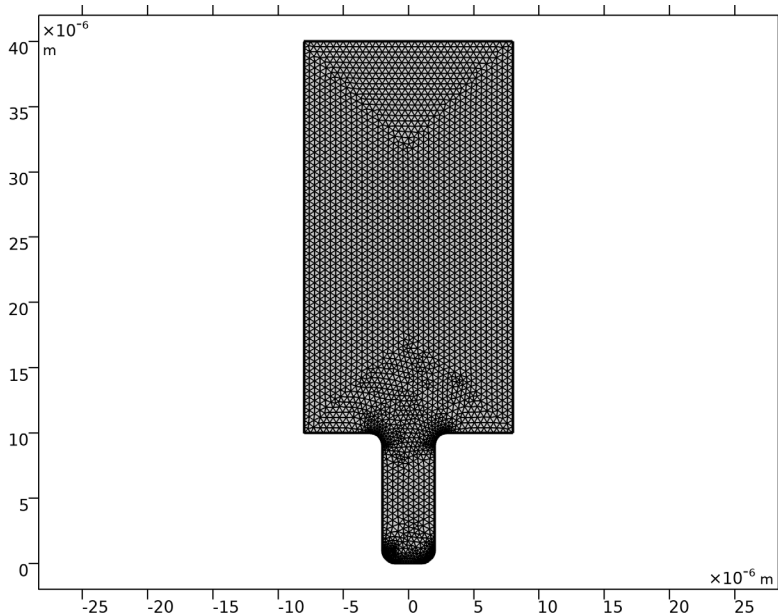

4 Click the Build All button .

The mesh should match this figure:



Study 1

Modify the times for the solver to simulate the deposition process during 5 s, storing the solution every 0.5 s. Then start the computation.

- 1 In the Model Builder expand the Study 1 node then click Step 2: Time Dependent .
- 2 In the Settings window under Study Settings and in the Times text field, enter range (0,0.5,5).
- 3 In the Study toolbar click Compute .

It only takes a few moments for the default plot and Solver Configurations nodes to be added to the Model Builder and for the plots to display in the Graphics window.

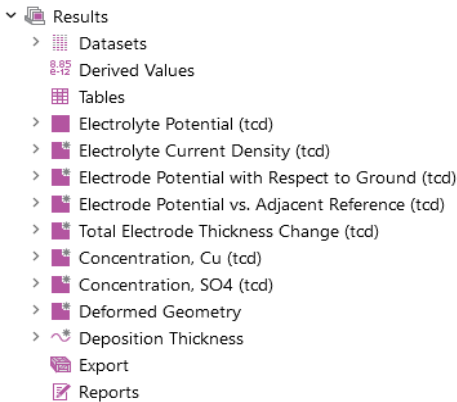



Results

Define the Default Concentration Plot Node

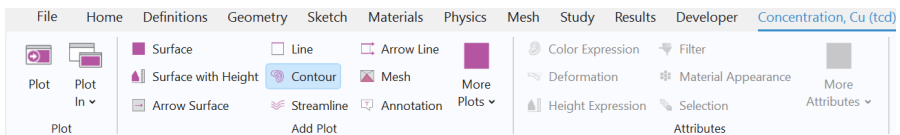
- 1 Under Results click the Concentration, Cu (tcd)  node. On the Concentration (tcd) toolbar click Contour .



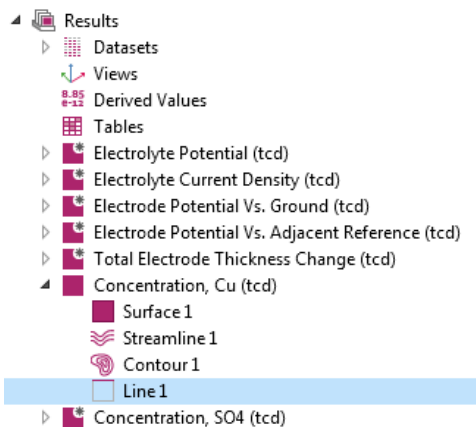

- 2 In the Settings window for Contour under Coloring and Style, from the Coloring list select Uniform and from the Color list, select Black and clear the Color legend checkbox.
- 3 On the Streamline  node, under Streamline Positioning and from the Positioning list, choose On selected boundaries. In the Number text field, enter 15.
- 4 From the Selection list choose anode.
- 5 On the Concentration, Cu (tcd) toolbar click Line  .



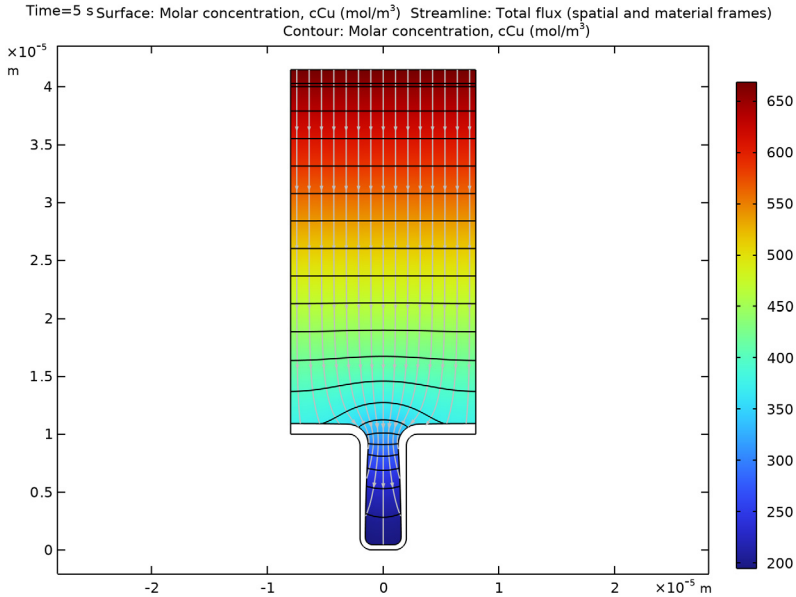

- 6 Under Data, choose Study1/Solution 1 as the Dataset and set Time(s) to the first value (0 s).
- 7 Under Coloring and Style, from the Coloring list select Uniform. From the Color list select Black.
- 8 Click the Plot button  .



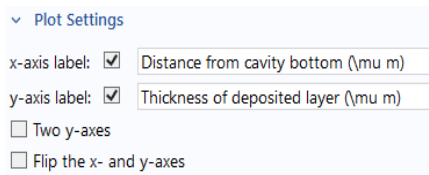

Add a ID Plot Group and Define a ID Line Graph

- 1 In the Home toolbar click Add Plot Group  and choose ID Plot Group .
- 2 Change the Label field to Deposition Thickness.
- 3 Click to expand the Title section. Select Manual and enter (or copy and paste) Profile of deposited layer on vertical wall as the title.
- 4 Under Plot Settings:
 - Select the x-axis label checkbox and enter Distance from cavity bottom (μ m).
 - Select the y-axis label checkbox and enter Thickness of deposited layer (μ m).



- 5 On the toolbar, click Line Graph .
- 6 In the Settings window for Line Graph click the Paste Selection button  and enter 4 in the Selection text field.

- 7 Under y-Axis Data, in the Expression text field, enter $x - X_g$ and select micrometer in the Unit list.
- 8 Under x-Axis Data, from the Parameter list, select Expression. In the Expression text field, enter y and select micrometer in the Unit list.
- 9 Click the Plot button  .

▼ y-Axis Data ← →  

Expression:

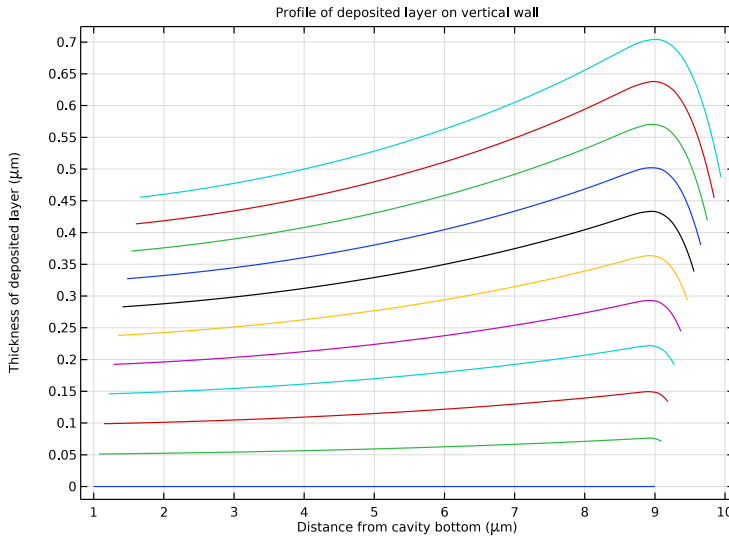

Unit:

Description:



Automatic Remeshing

Extend the simulation time to 14 seconds and recompute. Enable automatic remeshing in order to remesh the geometry if the mesh quality gets too low. First, add another Study node from the Model Wizard.

- 1 In the Home toolbar click Add Study .
- 2 Go to the Add Study window. Find the Studies subsection. In the tree under Preset Studies, select Time Dependent with Initialization .
- 3 In the Add study window click Add Study .

4 Under the Study 2 node click Step 2: Time Dependent .

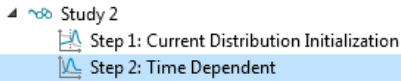

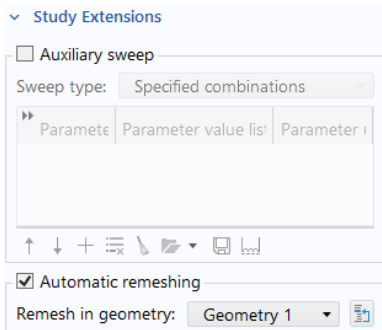

5 In the Settings window under Study Settings, in the Times text field, enter range (0, 1, 14).

6 Find and expand the Study Extensions section. Select the Automatic remeshing checkbox.



7 In the Home toolbar click Compute .

Concentration Plot after 14 s

In the Model Builder under Results, click the Concentration, Cu(tcd)  Plot Group and change Dataset to Study 2/Remeshed Solution 1. Change 'Time (s):' under Data to 14 and press Plot .

Now you will see the results of the new simulation.

