

# Electrochemistry Module

User's Guide

# Electrochemistry Module User's Guide

© 1998–2025 COMSOL

Protected by patents listed on [www.comsol.com/patents](http://www.comsol.com/patents), or see Help > About COMSOL Multiphysics on the File menu in the COMSOL Desktop for less detailed lists of U.S. Patents that may apply. Patents pending.

This Documentation and the Programs described herein are furnished under the COMSOL Software License Agreement ([www.comsol.com/sla](http://www.comsol.com/sla)) and may be used or copied only under the terms of the license agreement.

COMSOL, the COMSOL logo, COMSOL Multiphysics, COMSOL Desktop, COMSOL Compiler, COMSOL Server, and LiveLink are either registered trademarks or trademarks of COMSOL AB. All other trademarks are the property of their respective owners, and COMSOL AB and its subsidiaries and products are not affiliated with, endorsed by, sponsored by, or supported by those trademark owners. For a list of such trademark owners, see [www.comsol.com/trademarks](http://www.comsol.com/trademarks).

Version: COMSOL 6.4

## Contact Information

Visit the Contact COMSOL page at [www.comsol.com/contact](http://www.comsol.com/contact) to submit general inquiries or search for an address and phone number. You can also visit the Worldwide Sales Offices page at [www.comsol.com/contact/offices](http://www.comsol.com/contact/offices) for address and contact information.

If you need to contact Support, an online request form is located on the COMSOL Access page at [www.comsol.com/support/case](http://www.comsol.com/support/case). Useful links:

- Support Center: [www.comsol.com/support](http://www.comsol.com/support)
- Product Download: [www.comsol.com/product-download](http://www.comsol.com/product-download)
- Product Updates: [www.comsol.com/product-update](http://www.comsol.com/product-update)
- COMSOL Blog: [www.comsol.com/blogs](http://www.comsol.com/blogs)
- Discussion Forum: [www.comsol.com/forum](http://www.comsol.com/forum)
- Events: [www.comsol.com/events](http://www.comsol.com/events)
- COMSOL Video Gallery: [www.comsol.com/videos](http://www.comsol.com/videos)
- Support Knowledge Base: [www.comsol.com/support/knowledgebase](http://www.comsol.com/support/knowledgebase)
- Learning Center: [www.comsol.com/support/learning-center](http://www.comsol.com/support/learning-center)

Part number: CM024301

# C o n t e n t s

## Chapter 1: Introduction

<b>About the Electrochemistry Module</b>	<b>18</b>
What Can the Electrochemistry Module Do? . . . . .	18
The Electrochemistry Module Physics Interface Guide. . . . .	19
Common Physics Interface and Feature Settings and Nodes . . . . .	22
Electrochemistry Module Study Availability . . . . .	22
Where Do I Access the Documentation and Application Libraries? . . . .	23
<b>Overview of the User's Guide</b>	<b>27</b>

## Chapter 2: Modeling with Electrochemistry

<b>Introduction to Electrochemistry Modeling</b>	<b>30</b>
What Is Electrochemistry? . . . . .	30
Electrochemical Applications . . . . .	31
Fundamentals of Electrochemistry Modeling . . . . .	31
Current Distribution Cases and Choosing the Right Interface to Model an Electrochemical Cell . . . . .	33
Understanding the Different Approximations for Conservation of Charge in Electrolytes . . . . .	34
Modeling Electrochemical Reactions . . . . .	38
Double Layer Capacitance . . . . .	45
Porous Electrodes . . . . .	46
Boundary Conditions for Running and Controlling Electrochemical Cells . . . . .	47
Modeling Cyclic Voltammetry . . . . .	48
Common Simplifications When Modeling Electrochemical Cells . . . . .	48
Before You Start Building Your Model. . . . .	50
Meshing Advice . . . . .	52
Solving Electrochemical Models . . . . .	52
Postprocessing Your Solution . . . . .	57

# Chapter 3: Electrochemistry Interfaces

<b>The Primary and Secondary Current Distribution Interfaces</b>	<b>61</b>
The Primary Current Distribution and Secondary Current Distribution Interfaces . . . . .	61
Electrolyte . . . . .	64
Initial Values . . . . .	65
Porous Electrode. . . . .	65
Periodic Condition . . . . .	66
Thin Electrolyte Layer . . . . .	66
Edge Electrode. . . . .	67
Electrode Line Current Source . . . . .	68
Electrolyte Line Current Source . . . . .	68
Electrode Symmetry Axis Current Source . . . . .	69
Electrolyte Symmetry Axis Current Source . . . . .	69
External Current Source . . . . .	69
Electrode Point Current Source . . . . .	69
Electrolyte Point Current Source. . . . .	70
Electrode Current . . . . .	70
<b>The Tertiary Current Distribution, Nernst–Planck Interface</b>	<b>71</b>
The Tertiary Current Distribution, Nernst–Planck Interface . . . . .	71
Electrolyte . . . . .	76
Porous Electrode. . . . .	77
Separator. . . . .	78
Reactions. . . . .	78
Initial Values . . . . .	78
Ion-Exchange Membrane . . . . .	79
Ion-Exchange Membrane Boundary . . . . .	80
Thin Electrolyte Layer . . . . .	80
<b>Shared Physics Features in the Current Distribution Interfaces</b>	<b>82</b>
Domain, Boundary, Pair, Edge, and Point Nodes for the Electrochemistry Interfaces . . . . .	82
Current Conductor. . . . .	84
Highly Conductive Porous Electrode . . . . .	84

Electrode Current Source . . . . .	84
Electrolyte Current Source . . . . .	85
Porous Electrode Reaction . . . . .	85
Porous Matrix Double-Layer Capacitance . . . . .	86
Insulation. . . . .	87
Symmetry . . . . .	87
Electrode Surface. . . . .	87
Electrode Reaction . . . . .	92
Double-Layer Capacitance . . . . .	97
Perforated Electrode Surface . . . . .	98
Internal Electrode Surface . . . . .	98
Thin Electrode Surface. . . . .	99
Electrolyte Potential . . . . .	99
Electrolyte Current. . . . .	100
Electrolyte Current Density. . . . .	100
Thin Electrode Layer . . . . .	100
Electrode–Electrolyte Boundary Interface . . . . .	101
Electric Ground . . . . .	102
Electric Potential . . . . .	102
Electrode Current Density . . . . .	103
Electrode Current . . . . .	103
Electrode Power . . . . .	104
Harmonic Perturbation . . . . .	104
Electrode Potential . . . . .	105
External Short . . . . .	105
Initial Values for Adsorbing–Desorbing Species . . . . .	106
Reference Electrode . . . . .	106
Electric Reference Potential. . . . .	106
Load Cycle . . . . .	106
Current, Voltage, and Rest . . . . .	108
Circuit Terminal . . . . .	110
<b>The Aqueous Electrolyte Transport Interface</b> . . . . .	<b>111</b>
Species Nodes in the Aqueous Electrolyte Transport Interface . . . . .	115
Diffusion and Migration Settings . . . . .	116
Domain, Boundary, and Pair Nodes for the Aqueous Electrolyte	
Transport Interface . . . . .	116
Electrolyte . . . . .	117

Fully Dissociated Species . . . . .	118
Uncharged Species . . . . .	118
Weak Acid . . . . .	118
Weak Base . . . . .	118
Ampholyte . . . . .	119
Carbonic Acid . . . . .	119
Complex Species . . . . .	120
Highly Conductive Porous Electrode . . . . .	120
Porous Electrode Reaction . . . . .	121
Separator. . . . .	122
Initial Values . . . . .	122
Electrode Surface. . . . .	122
Electrode Reaction . . . . .	123
Reaction . . . . .	126
Potential . . . . .	127
Species Source. . . . .	127
No Flux . . . . .	127
Flux . . . . .	127
Reservoir. . . . .	127
Inflow . . . . .	128
Outflow . . . . .	128
<b>The Concentrated Electrolyte Transport Interface</b>	<b>130</b>
Electrolyte . . . . .	132
Diffusion Coefficients . . . . .	133
Separator. . . . .	133
Initial Values . . . . .	134
Species Sources . . . . .	134
Reference Electrode . . . . .	134
No Flux . . . . .	135
Flux . . . . .	135
Inflow . . . . .	135
Outflow . . . . .	135
Electrolyte Potential . . . . .	135
<b>The Electrode, Shell Interface</b>	<b>136</b>
Boundary, Edge, Point, and Pair Nodes for the Electrode, Shell Interface. . . . .	137

Electrode . . . . .	138
Initial Values . . . . .	139
External Current Density . . . . .	139
Current Source . . . . .	139
Normal Current Density . . . . .	140
Electric Insulation . . . . .	140
Boundary Current Source . . . . .	140
Ground . . . . .	140
Electric Potential . . . . .	141
<b>The Electroanalysis Model Wizard Entry</b>	<b>142</b>
<b>Theory for the Current Distribution Interfaces</b>	<b>143</b>
The Nernst–Planck Equations . . . . .	143
Domain Equations for Primary and Secondary Current Distributions . . . . .	145
Electrochemical Reactions and the Difference Between a Primary and a Secondary Current Distribution . . . . .	146
Domain Equations for Tertiary Current Distributions Using the Nernst–Planck Equations and Electroneutrality . . . . .	149
Mass Fluxes and Sources Due to Electrochemical Reactions . . . . .	150
Deposition–Dissolution Rates, Growth Velocities, and Thicknesses on an Electrode Surface . . . . .	151
Stoichiometric Coefficients for Double Layer Capacitive Charging . . . . .	152
Film Resistance . . . . .	153
Equilibrium Potentials and the Nernst Equation . . . . .	153
Electrode Kinetics Expressions . . . . .	154
Theory for Specific Current Distribution Feature Nodes. . . . .	159
Reference . . . . .	167
<b>Theory for the Aqueous Electrolyte Transport Interface</b>	<b>168</b>
<b>Theory for the Concentrated Electrolyte Transport Interface</b>	<b>173</b>
Dependent Variables, Species, and Electrolyte Components . . . . .	173
Volumetric Equations of State . . . . .	174
Flux Definitions and Material Balances . . . . .	175
Chemical Potentials and the Stefan–Maxwell–Onsager Relations . . . . .	176
The Reference Electrode. . . . .	177
Reference . . . . .	178

<b>Theory for Electrochemical Heat Sources</b>	<b>179</b>
The First Law of Thermodynamics . . . . .	180
Electrochemical Contributions to The Heat Equation . . . . .	180
Joule Heating Due to Charge Transport . . . . .	181
Heating Due to Electrochemical Reactions . . . . .	182
Heating Due to Heat of Mixing . . . . .	184
Total Overpotential Calculation for Concentration Dependent Kinetics .	184
References . . . . .	185
<b>Theory for Electrochemical Power Losses</b>	<b>186</b>
<b>Theory for the Electrode, Shell Interface</b>	<b>188</b>
Governing Equations . . . . .	188
Coupling to Other Physics Interfaces . . . . .	188
<b>Theory for Electroanalysis</b>	<b>190</b>
Electroanalytical Methods . . . . .	190
Supporting Electrolyte . . . . .	190
Domain Equations for the Electroanalysis Case . . . . .	191
Electrode Boundary Conditions in the Electroanalysis Model . . . . .	193
The Electroanalytical Butler–Volmer Equation . . . . .	195
Counter Electrodes and Overall Charge Balance . . . . .	196
<b>Electrode Potentials and Reference Electrodes</b>	<b>197</b>
Reference Electrodes . . . . .	197
Boundary Conditions Using Reference Electrode Potentials . . . . .	198
Nodes for Handling Electrode Potentials and Reference Electrodes . . .	198
<b>Solving Electrochemical Models</b>	<b>200</b>
General Current Distribution Problems . . . . .	200
Electrochemistry Coupled to Mass Transport, Battery, and Tertiary	
Current Distribution Models . . . . .	201
Setting up a Study Sequence for Multiphysics Problems . . . . .	202
Time-Dependent Problems with Load Steps . . . . .	203
Solver Settings . . . . .	203

## Chapter 4: Chemical Species Transport Interfaces

<b>The Transport of Diluted Species Interface</b>	<b>206</b>
The Transport of Diluted Species in Porous Media Interface . . . . .	210
Domain, Boundary, and Pair Nodes for the Transport of Diluted Species Interface. . . . .	211
Prescribing Conditions on Fluid–Solid Interfaces . . . . .	213
Species Properties . . . . .	213
Fluid . . . . .	214
Solid . . . . .	216
Initial Values . . . . .	217
Mass-Based Concentrations. . . . .	217
Reactions. . . . .	218
No Flux . . . . .	219
Inflow . . . . .	220
Outflow . . . . .	221
Concentration . . . . .	221
Flux . . . . .	222
Symmetry . . . . .	223
Flux Discontinuity . . . . .	223
Partition Condition . . . . .	224
Periodic Condition . . . . .	225
Line Mass Source. . . . .	226
Point Mass Source . . . . .	227
Open Boundary . . . . .	228
Thin Diffusion Barrier . . . . .	228
Thin Impermeable Barrier . . . . .	228
Equilibrium Reaction . . . . .	229
Surface Reactions . . . . .	230
Surface Equilibrium Reaction . . . . .	231
Fast Irreversible Surface Reaction . . . . .	231
Porous Electrode Coupling . . . . .	232
Reaction Coefficients . . . . .	232
Electrode Surface Coupling . . . . .	233
Porous Medium . . . . .	233
Fluid (Porous Medium) . . . . .	234
Porous Matrix . . . . .	236

Dispersion . . . . .	236
Unsaturated Porous Medium . . . . .	237
Liquid . . . . .	238
Gas . . . . .	240
Adsorption . . . . .	240
Volatilization . . . . .	242
Species Source. . . . .	243
Hygroscopic Swelling . . . . .	244
Out-of-Plane Flux . . . . .	244
Fracture . . . . .	247
Fluid (Fracture) . . . . .	247
Fracture Material. . . . .	248
<b>The Chemistry Interface</b>	<b>249</b>
Mixture Properties . . . . .	250
Feature Nodes Available for the Chemistry Interface . . . . .	254
Reaction . . . . .	254
Species . . . . .	262
Electrode Reaction . . . . .	265
Electrode Reaction Group . . . . .	267
Reversible Reaction Group . . . . .	267
Equilibrium Reaction Group. . . . .	269
Species Group. . . . .	270
Species Activity . . . . .	270
Species Thermodynamics. . . . .	270
<b>The Nernst–Planck–Poisson Equations Interface</b>	<b>271</b>
<b>The Electrophoretic Transport Interface</b>	<b>273</b>
Common Settings for the Species Nodes in the Electrophoretic Transport Interface . . . . .	277
Diffusion and Migration Settings . . . . .	278
Domain, Boundary, and Pair Nodes for the Electrophoretic Transport Interface. . . . .	279
Solvent . . . . .	280
Porous Matrix Properties . . . . .	281
Fully Dissociated Species . . . . .	281
Uncharged Species . . . . .	281

Weak Acid . . . . .	281
Weak Base . . . . .	282
Ampholyte . . . . .	282
Protein . . . . .	282
Current Source . . . . .	283
Initial Potential. . . . .	283
Current . . . . .	283
Current Density . . . . .	283
Insulation. . . . .	283
Potential . . . . .	284
Species Source. . . . .	284
Initial Concentration . . . . .	284
Concentration. . . . .	285
No Flux . . . . .	285
Flux . . . . .	285
Inflow . . . . .	286
Outflow . . . . .	286

**The Surface Reactions Interface 287**

Boundary, Edge, Point, and Pair Nodes for the Surface Reactions	
Interface. . . . .	288
Surface Properties . . . . .	289
Initial Values . . . . .	290
Reactions. . . . .	290
Surface Concentration. . . . .	291

**Theory for the Transport of Diluted Species Interface 292**

Mass Balance Equation. . . . .	293
Equilibrium Reaction Theory . . . . .	294
Material Balance Formulation . . . . .	296
Solving a Diffusion Equation Only . . . . .	296
Mass Sources for Species Transport . . . . .	297
Adding Transport Through Migration . . . . .	299
Supporting Electrolytes . . . . .	300
Crosswind Diffusion . . . . .	301
Danckwerts Inflow Boundary Condition . . . . .	302
Mass Balance Equation for Transport of Diluted Species in Porous	
Media. . . . .	303

Convection in Porous Media . . . . .	304
Diffusion in Porous Media . . . . .	306
Dispersion . . . . .	307
Adsorption . . . . .	309
Reactions. . . . .	311
Mass Transport in Fractures . . . . .	312
References . . . . .	313
<b>Theory for the Electrophoretic Transport Interface</b>	<b>315</b>
<b>Theory for the Surface Reactions Interface</b>	<b>321</b>
Governing Equations for the Surface Concentrations . . . . .	321
Governing Equations for the Bulk Concentrations . . . . .	322
ODE Formulations for Surface Concentrations . . . . .	324
Surface Reaction Equations on Deforming Geometries . . . . .	325
Reference for the Surface Reactions Interface . . . . .	326
<b>Theory for the Coupling of Mass Transport to Electrochemical Reactions</b>	<b>327</b>
Molar Sources and Sinks . . . . .	327
Mass Sources and Sinks . . . . .	328

## Chapter 5: Fluid Flow Interfaces

<b>The Laminar Flow and Creeping Flow Interfaces</b>	<b>330</b>
The Creeping Flow Interface . . . . .	330
The Laminar Flow Interface . . . . .	331
Domain, Boundary, Pair, and Point Nodes for Single-Phase Flow . . . . .	337
Fluid Properties . . . . .	337
Volume Force . . . . .	339
Initial Values . . . . .	339
Wall . . . . .	340
Inlet. . . . .	342
Outlet. . . . .	346
Symmetry . . . . .	349
Open Boundary . . . . .	349

Boundary Stress . . . . .	350
Periodic Flow Condition . . . . .	352
Porous Interface . . . . .	354
Flow Continuity . . . . .	354
Pressure Point Constraint . . . . .	355
Average Pressure. . . . .	356
Point Mass Source . . . . .	356
Line Mass Source. . . . .	357
Gravity . . . . .	358
Rotating Frame . . . . .	358

**The Darcy's Law Interface 360**

Domain, Boundary, Edge, Point, and Pair Nodes for the Darcy's Law Interface . . . . .	362
Porous Medium . . . . .	364
Fluid . . . . .	366
Porous Matrix . . . . .	368
Unsaturated Porous Medium . . . . .	371
Dual Porosity Medium . . . . .	373
Dual Permeability Medium . . . . .	375
Unsaturated Dual Permeability Medium . . . . .	377
Macropores. . . . .	379
Micropores . . . . .	381
Mass Source . . . . .	383
Contributing Velocity . . . . .	383
Initial Values . . . . .	384
Gravity . . . . .	385
Cross Section . . . . .	386
Thickness. . . . .	387
Porous Electrode Coupling . . . . .	387
Electrode Surface Coupling . . . . .	388
Pressure . . . . .	389
Mass Flux. . . . .	390
Line Mass Source. . . . .	391
Point Mass Source . . . . .	392
Inlet. . . . .	393
Symmetry . . . . .	395
No Flow . . . . .	395

Flux Discontinuity . . . . .	396
Outlet . . . . .	397
Precipitation . . . . .	398
Periodic Condition . . . . .	398
Interior Wall . . . . .	399
Barrier . . . . .	399
Pressure Head . . . . .	400
Hydraulic Head . . . . .	401
Atmosphere/Gauge . . . . .	401
Pervious Layer . . . . .	402
Well . . . . .	404
Fracture . . . . .	404
Fluid (Fracture) . . . . .	407
Fracture Material . . . . .	408
<b>The Free and Porous Media Flow, Brinkman Interface</b>	<b>411</b>
Domain, Boundary, Point, and Pair Nodes for the Free and Porous Media Flow, Brinkman Interface . . . . .	414
Fluid Properties . . . . .	415
Porous Medium . . . . .	416
Fluid . . . . .	416
Porous Matrix . . . . .	418
Mass Source . . . . .	419
Volume Force . . . . .	419
Porous Electrode Coupling . . . . .	419
Initial Values . . . . .	420
Gravity . . . . .	420
Rotating Frame . . . . .	420
Electrode–Electrolyte Interface Coupling . . . . .	421
Wall . . . . .	422
<b>The Free and Porous Media Flow, Darcy Interface</b>	<b>423</b>
Free and Porous Media Flow Coupling (Multiphysics Coupling) . . . . .	423
<b>The Brinkman Equations Interface</b>	<b>427</b>
Domain, Boundary, Point, and Pair Nodes for the Brinkman Equations Interface . . . . .	431
Porous Medium . . . . .	432

Fluid . . . . .	434
Porous Matrix . . . . .	435
Mass Source . . . . .	437
Volume Force . . . . .	437
Initial Values . . . . .	438
Fluid Properties . . . . .	438
Gravity . . . . .	440
Rotating Frame . . . . .	440
<b>Theory for the Laminar Flow and Creeping Flow Interfaces</b>	<b>442</b>
General Single-Phase Flow Theory . . . . .	443
Compressible Flow . . . . .	445
Weakly Compressible Flow . . . . .	445
The Mach Number Limit . . . . .	445
Incompressible Flow . . . . .	446
The Reynolds Number. . . . .	447
Gravity . . . . .	448
Rotating Frame . . . . .	449
Theory for the Wall Boundary Condition . . . . .	450
Prescribing Inlet and Outlet Conditions . . . . .	454
Fully Developed Flow (Inlet) . . . . .	456
Fully Developed Flow (Outlet). . . . .	457
No Viscous Stress . . . . .	459
Normal Stress Boundary Condition. . . . .	459
Pressure Boundary Condition . . . . .	460
Porous Interface . . . . .	462
Mass Sources for Fluid Flow . . . . .	465
Numerical Stability — Stabilization Techniques for Fluid Flow . . . . .	467
Solvers for Laminar Flow. . . . .	469
Pseudo Time Stepping for Laminar Flow Models . . . . .	471
Nitsche Constraints. . . . .	473
Particle Tracing in Fluid Flow . . . . .	473
References for the Single-Phase Flow, Laminar Flow Interfaces . . . . .	474
<b>Theory for the Darcy's Law Interface</b>	<b>477</b>
About Darcy's Law . . . . .	477
Darcy's Law — Equation Formulation . . . . .	478
Storage Models . . . . .	479

Average Linear Velocity . . . . .	480
Dual Porosity and Dual Permeability Theory . . . . .	480
References for the Darcy's Law Interface. . . . .	482
<b>Theory for the Free and Porous Media Flow, Brinkman Interface</b>	<b>484</b>
Reference for the Free and Porous Media Flow, Brinkman Interface . . .	484
<b>Theory for the Free and Porous Media Flow, Darcy Interface 485</b>	
References . . . . .	487
<b>Theory for the Brinkman Equations Interface</b>	<b>488</b>
About the Brinkman Equations . . . . .	488
Brinkman Equations Theory. . . . .	488
References for the Brinkman Equations Interface. . . . .	490
<b>Theory for the Coupling of Fluid Flow to Electrochemical Reactions</b>	<b>491</b>
Momentum Sources and Sinks . . . . .	491

## Chapter 6: Heat Transfer

## Chapter 7: Multiphysics Coupling Nodes

Electrochemical Heating . . . . .	498
Potential Coupling . . . . .	498
Space Charge Density Coupling . . . . .	498

## Chapter 8: Glossary

<b>Glossary of Terms</b>	<b>502</b>
<b>Index</b>	<b>507</b>

# Introduction

This guide describes the Electrochemistry Module, an optional add-on package for COMSOL Multiphysics®.

This chapter introduces you to the capabilities of this module including an introduction to the modeling stages and some realistic and illustrative models. A summary of the physics interfaces and where you can find documentation and model examples is also included. The last section is a brief overview with links to each chapter in this guide.

In this chapter:

- [About the Electrochemistry Module](#)
- [Overview of the User's Guide](#)

# About the Electrochemistry Module

These topics are included in this section:

- [What Can the Electrochemistry Module Do?](#)
- [The Electrochemistry Module Physics Interface Guide](#)
- [Common Physics Interface and Feature Settings and Nodes](#)
- [Electrochemistry Module Study Availability](#)
- [Where Do I Access the Documentation and Application Libraries?](#)



[The Physics Interfaces and Building a COMSOL Multiphysics Model in the \*COMSOL Multiphysics Reference Manual\*](#)

---

## *What Can the Electrochemistry Module Do?*

---

The Electrochemistry Module extends the COMSOL Multiphysics environment with customized physics interfaces for modeling of electrochemical cells, with tools for building detailed models of the configuration of electrodes and electrolyte. The physics interfaces include descriptions of the electrochemical reactions and the transport properties that influence the behavior of various types of electrochemical cells. With this module, you have the perfect tools to investigate the influence of using different materials, geometric configurations, and operating conditions on the behavior of a cell.

The targeted applications for this module are the following:

- Electroanalysis
- Rotating disc electrodes
- Voltammetry
- Chronoamperometry
- Electrochemical impedance spectroscopy
- Electrochemical sensors
- Electrolysis
- Electrodialysis
- Biosensors
- Electrochemical nanotechnology

The physics interfaces include chemical species transport, charge balances, heat transfer, and fluid flow. You can use the module to model electrochemical and electroanalytical procedures in electrochemical cells at different operating conditions for different electrode configurations, structures, and dimensions; and different electrode and electrolyte materials and chemistry.

The module adds the electrochemistry interfaces, which contains the Electroanalysis interface and the Primary Current Distribution, Secondary Current Distribution, and Tertiary Current Distribution, Nernst-Planck interfaces. The current distribution interfaces are available for solid nonporous electrodes and for porous electrodes. General tertiary current distribution models can also be set up using the Chemical Species Transport interfaces.

The tailored physics interfaces mentioned above are also complemented with extended functionality in other physics interfaces for chemical species transport, heat transfer, and fluid flow.

The physics interfaces for chemical species transport of neutral species are extended by adding functionality that directly couples to electrochemical reactions defined in the physics interfaces for electrochemical cells.

[Heat Transfer](#) includes heat sources that describe ohmic losses in the electrodes and electrolyte and heat sources due to electrochemical reactions in electrochemical cells.

The fluid flow capabilities are extended for laminar flow, where the chemical species transport and the energy balances influence the properties of the flow.

### *The Electrochemistry Module Physics Interface Guide*













---











The Electrochemistry Module extends the functionality of the physics interfaces for the base package of COMSOL Multiphysics. The details of the physics interfaces and study types for the Electrochemistry Module are listed in the table. The functionality of the COMSOL Multiphysics base package is listed in the *COMSOL Multiphysics Reference Manual*.







In the *COMSOL Multiphysics Reference Manual*:

- [Studies and Solvers](#)
- [The Physics Interfaces](#)
- For a list of all the core physics interfaces included with a COMSOL Multiphysics license, see [Physics Interface Guide](#).

PHYSICS INTERFACE	ICON	TAG	SPACE DIMENSION	AVAILABLE STUDY TYPE
 <b>Chemical Species Transport</b>				
Transport of Diluted Species		tds	all dimensions	stationary; time dependent
Chemistry		chem	all dimensions	stationary; time dependent
Nernst–Planck–Poisson Equations		tds+es	all dimensions	stationary; time dependent; stationary source sweep; small-signal analysis, frequency domain
Electrophoretic Transport		el	all dimensions	stationary; stationary with initialization; time dependent; time dependent with initialization
Transport of Diluted Species in Porous Media		tds	all dimensions	stationary; time dependent
Surface Reactions		sr	all dimensions	stationary (3D, 2D, and 2D axisymmetric models only); time dependent
 <b>Reacting Flow</b>				
Laminar Flow, Diluted Species		—	3D, 2D, 2D axisymmetric	stationary; time dependent
 <b>Electrochemistry</b>				
Primary Current Distribution		cd	all dimensions	stationary; stationary with initialization; time dependent; time dependent with initialization
Secondary Current Distribution				AC impedance, initial values; AC impedance, stationary; AC impedance, time dependent

PHYSICS INTERFACE	ICON	TAG	SPACE DIMENSION	AVAILABLE STUDY TYPE
Tertiary Current Distribution, Nernst–Planck (Electroneutrality, Water-Based with Electroneutrality, Supporting Electrolyte, Poisson)		tcd	all dimensions	stationary; stationary with initialization; time dependent; time dependent with initialization; AC impedance, initial values; AC impedance, stationary; AC impedance, time dependent
Aqueous Electrolyte Transport		aqt	all dimensions	stationary; stationary with initialization; time dependent; time dependent with initialization
Concentrated Electrolyte Transport		cet	all dimensions	stationary; stationary with initialization; time dependent; time dependent with initialization;
Electroanalysis		tcd	all dimensions	stationary; time dependent; AC impedance, initial values; AC impedance, stationary; AC impedance, time dependent; cyclic voltammetry
Electrode, Shell		els	3D, 2D, 2D axisymmetric	stationary; time dependent
 <b>Fluid Flow</b>				
 <b>Porous Media and Subsurface Flow</b>				
Brinkman Equations		br	3D, 2D, 2D axisymmetric	stationary; time dependent
Darcy's Law		dl	all dimensions	stationary; time dependent
Free and Porous Media Flow, Brinkman		fp	3D, 2D, 2D axisymmetric	stationary; time dependent
Free and Porous Media Flow, Darcy		—	3D, 2D, 2D axisymmetric	stationary; time dependent

PHYSICS INTERFACE	ICON	TAG	SPACE DIMENSION	AVAILABLE STUDY TYPE
 <b>Nonisothermal Flow</b>				
Brinkman Equations		—	3D, 2D, 2D axisymmetric	stationary; time dependent; stationary, one-way NITF; time dependent, one-way NITF
 <b>Heat Transfer</b>				
Heat Transfer in Porous Media		ht	all dimensions	stationary; time dependent

### *Common Physics Interface and Feature Settings and Nodes*

There are several common settings and sections available for the physics interfaces and feature nodes. Some of these sections also have similar settings or are implemented in the same way no matter the physics interface or feature being used. There are also some physics feature nodes that display in COMSOL Multiphysics.

In each module's documentation, only unique or extra information is included; standard information and procedures are centralized in the *COMSOL Multiphysics Reference Manual*.



In the *COMSOL Multiphysics Reference Manual* see [Table 2-4](#) for links to common sections and [Table 2-5](#) to common feature nodes. You can also search for information: press F1 to open the **Help** window or Ctrl+F1 to open the **Documentation** window.

### *Electrochemistry Module Study Availability*



[Studies and Solvers](#) in the *COMSOL Multiphysics Reference Manual*

TABLE I-1: MODULE DEPENDENT PHYSICS INTERFACES AND STUDY AVAILABILITY.

PHYSICS INTERFACE	NAME	PRESET STUDIES*			
		STATIONARY	TIME DEPENDENT	AC IMPEDANCE STATIONARY	AC IMPEDANCE TIME DEPENDENT
Surface Reactions	sr	√	√		
Transport of Diluted Species	tds	√	√		
Transport of Diluted Species in Porous Media	tds	√	√		
Primary Current Distribution	siec	√			
Secondary Current Distribution	siec	√	√	√	√
Tertiary Current Distribution, Nernst-Planck	tcdee	√	√	√	√
Electroanalysis	elan	√	√	√	√
Laminar Flow	spf	√	√		
Brinkman Equations	br	√	√		
Darcy's Law	dl	√	√		
Free and Porous Media Flow, Brinkman	fp	√	√		
Free and Porous Media Flow, Darcy	-	√	√		
Heat Transfer in Porous Media	ht	√	√		
* Custom studies are also available					

### *Where Do I Access the Documentation and Application Libraries?*

A number of online resources have more information about COMSOL, including licensing and technical information. The electronic documentation, topic-based (or

context-based) help, and the Application Libraries are all accessed through the COMSOL Desktop.



If you are reading the documentation as a PDF file on your computer, the [blue links](#) do not work to open an application or content referenced in a different guide. However, if you are using the Help system in COMSOL Multiphysics, these links work to open other modules, application examples, and documentation sets.

## THE DOCUMENTATION AND ONLINE HELP



The *COMSOL Multiphysics Reference Manual* describes the core physics interfaces and functionality included with the COMSOL Multiphysics license. This book also has instructions on how to use COMSOL Multiphysics and how to access the electronic Documentation and Help content.

### *Opening Topic-Based Help*

The Help window is useful as it is connected to the features in the COMSOL Desktop. To learn more about a node in the Model Builder, or a window on the Desktop, click to highlight a node or window, then press F1 to open the Help window, which then displays information about that feature (or click a node in the Model Builder followed by the **Help** button (  ). This is called *topic-based* (or *context*) *help*.

Win

To open the **Help** window:

- In the **Model Builder**, **Application Builder**, or **Physics Builder**, click a node or window and then press F1.
- On any toolbar (for example, **Home**, **Definitions**, or **Geometry**), hover the mouse over a button (for example, **Add Physics** or **Build All**) and then press F1.
- From the **File** menu, click **Help** (  ).
- In the upper-right corner of the COMSOL Desktop, click the **Help** (  ) button.

Mac	<p>To open the <b>Help</b> window:</p> <ul style="list-style-type: none"> <li>• In the <b>Model Builder</b> or <b>Physics Builder</b>, click a node or window and then press F1.</li> </ul>
Linux	<ul style="list-style-type: none"> <li>• In the main toolbar, click the <b>Help</b> (  ) button.</li> <li>• From the main menu, select <b>Help &gt; Help</b>.</li> </ul>

*Opening the Documentation Window*

Mac	<p>To open the <b>Documentation</b> window:</p> <ul style="list-style-type: none"> <li>• Press Ctrl+F1.</li> </ul>
Linux	<ul style="list-style-type: none"> <li>• In the main toolbar, click the <b>Documentation</b> (  ) button.</li> <li>• From the main menu, select <b>Help &gt; Documentation</b>.</li> </ul>

**THE APPLICATION LIBRARIES WINDOW**

Each model or application includes documentation with the theoretical background and step-by-step instructions to create a model or application. The models and applications are available in COMSOL Multiphysics as MPH files that you can open for further investigation. You can use the step-by-step instructions and the actual models as templates for your own modeling. In most models, SI units are used to describe the relevant properties, parameters, and dimensions, but other unit systems are available.

Once the Application Libraries window is opened, you can search by name or browse under a module folder name. Click to view a summary of the model or application and its properties, including options to open it or its associated PDF document.

*Opening the Application Libraries Window*

To open the **Application Libraries** window (  ):

**CONTACTING COMSOL BY EMAIL**

For general product information, contact COMSOL at [info@comsol.com](mailto:info@comsol.com).

**COMSOL ACCESS AND TECHNICAL SUPPORT**

To receive technical support from COMSOL for the COMSOL products, please contact your local COMSOL representative or send your questions to [support@comsol.com](mailto:support@comsol.com). An automatic notification and a case number will be sent to you

by email. You can also access technical support, software updates, license information, and other resources by registering for a COMSOL Access account.

#### **COMSOL ONLINE RESOURCES**

COMSOL website	<a href="http://www.comsol.com">www.comsol.com</a>
Contact COMSOL	<a href="http://www.comsol.com/contact">www.comsol.com/contact</a>
COMSOL Access	<a href="http://www.comsol.com/access">www.comsol.com/access</a>
Support Center	<a href="http://www.comsol.com/support">www.comsol.com/support</a>
Product Download	<a href="http://www.comsol.com/product-download">www.comsol.com/product-download</a>
Product Updates	<a href="http://www.comsol.com/product-update">www.comsol.com/product-update</a>
COMSOL Blog	<a href="http://www.comsol.com/blogs">www.comsol.com/blogs</a>
Discussion Forum	<a href="http://www.comsol.com/forum">www.comsol.com/forum</a>
Events	<a href="http://www.comsol.com/events">www.comsol.com/events</a>
COMSOL Application Gallery	<a href="http://www.comsol.com/models">www.comsol.com/models</a>
COMSOL Video Gallery	<a href="http://www.comsol.com/videos">www.comsol.com/videos</a>
Learning Center	<a href="http://www.comsol.com/support/learning-center">www.comsol.com/support/learning-center</a>
Support Knowledge Base	<a href="http://www.comsol.com/support/knowledgebase">www.comsol.com/support/knowledgebase</a>

# Overview of the User's Guide

The *Electrochemistry Module User's Guide* gets you started with modeling using COMSOL Multiphysics. The information in this guide is specific to this module. Instructions how to use COMSOL in general are included with the *COMSOL Multiphysics Reference Manual*.



As detailed in the section [Where Do I Access the Documentation and Application Libraries?](#) this information can also be searched from the COMSOL Multiphysics software **Help** menu.

## TABLE OF CONTENTS, GLOSSARY, AND INDEX

To help you navigate through this guide, see the [Contents](#), [Glossary of Terms](#), and [Index](#).

## MODELING WITH ELECTROCHEMISTRY

The [Modeling with Electrochemistry](#) chapter discusses a variety of topics, including [Fundamentals of Electrochemistry Modeling](#), [Modeling Electrochemical Reactions](#), [Modeling Cyclic Voltammetry](#), and [Postprocessing Your Solution](#).

## ELECTROCHEMISTRY INTERFACES

[Electrochemistry Interfaces](#) chapter describes the Primary Current Distribution, Secondary Current Distribution, Tertiary Current Distribution, Nernst-Planck, Current Distribution on Edges, BEM, Electrode, Shell, and Electroanalysis interfaces. The chapter also includes the underlying theory.

## CHEMICAL SPECIES TRANSPORT INTERFACES

[Chemical Species Transport Interfaces](#) chapter describes the Transport in Diluted Species, Transport of Diluted Species in Porous Media, and Surface Reactions interfaces. It also includes sections about the underlying theory for each physics interface.

## FLUID FLOW INTERFACES

[Fluid Flow Interfaces](#) chapter describes the Darcy's Law, the Brinkman Equations, the Free and Porous Media Flow, Brinkman, and the Free and Porous Media Flow, Darcy interfaces, including the underlying theory for each.

## **HEAT TRANSFER INTERFACES**

[Heat Transfer](#) chapter describes how to couple electrochemical heat sources to heat transfer.

## **THE MULTIPHYSICS COUPLING NODES**

The [Multiphysics Coupling Nodes](#) chapter describes the coupling nodes available under the Multiphysics node for coupling various electrochemical interfaces using potential or space charge density couplings, for example.

# Modeling with Electrochemistry

In this chapter you are given an [Introduction to Electrochemistry Modeling](#).

# Introduction to Electrochemistry Modeling

In this section:

- [What Is Electrochemistry?](#)
- [Electrochemical Applications](#)
- [Fundamentals of Electrochemistry Modeling](#)
- [Current Distribution Cases and Choosing the Right Interface to Model an Electrochemical Cell](#)
- [Understanding the Different Approximations for Conservation of Charge in Electrolytes](#)
- [Modeling Electrochemical Reactions](#)
- [Double Layer Capacitance](#)
- [Porous Electrodes](#)
- [Boundary Conditions for Running and Controlling Electrochemical Cells](#)
- [Modeling Cyclic Voltammetry](#)
- [Common Simplifications When Modeling Electrochemical Cells](#)
- [Before You Start Building Your Model](#)
- [Meshing Advice](#)
- [Solving Electrochemical Models](#)
- [Postprocessing Your Solution](#)

## *What Is Electrochemistry?*

---

An *electrochemical* process is one that either converts electric energy to chemical energy or converts chemical energy to electric energy.

In electrochemical reactions, chemicals react by gaining or losing electrons. Chemicals can exchange these electrons with an electrical conductor or circuit. The chemical potential — or thermodynamic driving force — for a chemical reaction is thus converted into an electric potential or voltage, which can be exploited to do useful work when an electric current is drawn.

## *Electrochemical Applications*

---

Electrochemical systems may be classified in different ways.

One approach is to contrast those electrochemical systems involving desirable reactions from those involving undesirable reactions. Synthetic *electrolysis* is an example of a desirable reaction because the chemical process is promoted to generate a desired product. Or, for example, when designing a battery we might want to set up conditions to promote an electrochemical reaction in order to extract useful energy.

*Corrosion* is an example of undesirable electrochemistry because in this case spontaneous electrochemical reactions destroy structural materials and so harm the integrity of a system: we aim to minimize the rate of these reactions.

Electrochemical systems can also be classified into systems that output energy or systems that consume energy. *Batteries and fuel cells* are energy extraction devices — an electrochemical reaction is used to convert the energy in chemical system into a voltage. Such cells are also called *galvanic cells*. By contrast, in *electrolysis*, the system consumes energy to promote an electrochemical reaction for synthesis. Similar electrochemical systems needing energy input include manufacturing processes such as *electroplating*. Electrochemical reactions may also be driven for *electroanalysis*, to quantify or otherwise explore the chemical constituents or reactivity of a system.

The different electrochemical modules in COMSOL Multiphysics are designed to offer tailored physics interfaces provision for each of these electrochemical situations. The underlying physical description provided by the general physics interfaces described below is common to all the modules — the differences between the modules lies in the particular expected system inputs and outputs and the intended behavior of the system.

## *Fundamentals of Electrochemistry Modeling*

---

Electrochemical systems consist of electrically conducting media. These may be classified as electrodes or electrolytes. An *electrode* carries current by transport of electrons; normally the electrode is a conventional electrical conductor such as a metal. The *electrolyte* carries current by transport of charged chemical species (ions). Electrolytes are often salt solutions in water but may include salt solutions in other liquid solvents, as well as solids, such as concrete, which can conduct by transport of oxide ions. The electric conductivity of an electrode is normally several orders of magnitude larger than the electric conductivity of an electrolyte.

## THE ELECTRODE-ELECTROLYTE INTERFACE

At the *electrode-electrolyte interface*, conventional electric current in the electrode is converted into ionic current in the electrolyte. According to the overall conservation of charge, these currents must balance here. The conversion between the two types of currents may arise due to electrochemical reaction (electrolysis) or capacitive charging.

Electrolysis occurs when a chemical species in the electrolyte exchanges one or more electrons with the electrode. Capacitive charging occurs when the potential of an electrode is changing, so that ions in the electrolyte are either attracted or repelled from the surface, drawing a current.

Batteries and fuel cells can also involve porous electrodes, in which an electrode material has a micro- or nanostructure that is permeable to an electrolyte solution. The advantage of such a material is the great increase in the area of the electrode-electrolyte interface.

Note that all current must move in circuits. An isolated electrode-electrolyte interface cannot draw a net current, but a system with two such interfaces can. An electrochemical system with two or more electrodes in contact with electrolyte is called an *electrochemical cell*.

In an electrochemical cell with two electrodes, these electrodes are identified as an *anode*, at which the electrochemical reaction transfers electrons from electrolyte to electrode, and a *cathode*, at which electrons are transferred from the electrode to the electrolyte. Note that it is the direction of the current that will determine if an electrode reaction is anodic or cathodic. For a battery, for instance, the location of the anode and cathode will change depending on whether the battery is charged or discharged. (The general habit in the battery community to always denounce the positive electrode as the “cathode” is hence strictly only correct during battery discharge.)

Conventional electric current is the flow of positive charge, which is then from anode to cathode through the electrolyte. A closed circuit, conserving overall system charge, is formed by the flow of electric current in the electrode domains (and any electrical circuitry) from cathode to anode, and by the transport of ions through the electrolyte domains from anode to cathode.

## OUTPUTS OF INTEREST FROM A MODEL

The experimentally measurable features of an electrochemical system are the external (lumped) current and voltage acting between the two electrodes. It is, in general, impossible to measure local current densities or potentials at different points on the

surface of a conducting electrode, or at arbitrary points within an electrochemical system.

The advantage of physical modeling is the ability to investigate the full space-dependent behavior of the system under a wide range of circumstances to identify the reasons for the observed current-voltage relationship, and so to identify the appropriate physical conditions to optimize current and voltage as required.

The overall current-voltage curve of an electrochemical cell is also known as a *polarization curve* or, in an analytical context, a *voltammogram*. These curves are not unique but rather depend on the means by which the current or voltage is altered, since these lumped parameters are related to multiple physical effects with different length and time scales. Hysteresis in practical polarization curves is not uncommon.

Polarization curves are frequently nonlinear. The combination of nonlinearity and hysteresis means that electrochemical cells do not necessarily resemble “ideal” electrical components (such as a circuit of resistors and capacitors) in the sense of giving a predictable and linear current-voltage response.



- [Potential Variables](#)
  - [Current Variables and Calculating the Total Cell Current](#)
- 

### *Current Distribution Cases and Choosing the Right Interface to Model an Electrochemical Cell*

---

COMSOL Multiphysics has many built-in physics interfaces aimed at specific applications. In many generic cases, however, the modeler has to make some basic assumptions about his system before starting to build his model.

Under the assumption of a linear relation of current density to electric field, Ohm’s law is obeyed for the electrolyte current. This is the assumption of *primary current distribution*, where one also assumes infinitely fast electrodes kinetics, resulting in negligible potential drops over the electrode-electrolyte interfaces. If the electrode reaction kinetics proceed at a finite rate, then the system has a *secondary current distribution*. In cases where more advanced nonlinear charge conservation equations and concentration-dependent electrode polarization are required, the system is described as obeying *tertiary current distribution*.

In some applications, especially within the field of *electroanalysis*, the potential gradients in the electrolyte are so small that the spatial distribution of current in the

electrolyte is not solved for. Such models are instead centered around the interplay of electrode kinetics and transport (by diffusion) of the reacting species in the vicinity of the electrode.

A rule-of-thumb flowchart for selecting a proper current distribution interface for a model is shown below. The recommendations here are indicative and the modeler may sometimes want to deviate from the suggested route; in particular, simpler descriptions are recommended at an earlier stage of model development. In the following sections we explain some of the theory behind this flowchart with regards to the description of the electrolyte charge transport and electrode reactions.

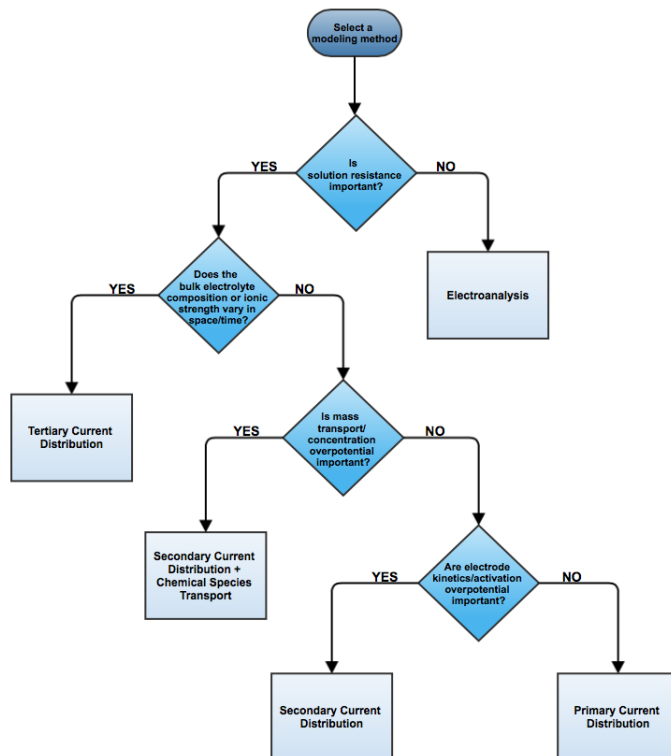

### *Understanding the Different Approximations for Conservation of Charge in Electrolytes*

Deciding how to model the charge transport in the electrolyte is usually the starting point when setting up an electrochemical model since this will determine what physics

interface you will use when starting to build your model. Different theoretical descriptions of the electrolyte current density are included in COMSOL Multiphysics. They are applicable in different circumstances as discussed in this section.

The electric displacement field in a medium is related to the local charge density according to Gauss's law, one of Maxwell's equations:

$$\nabla \cdot \mathbf{D} = \rho_v$$

In electrolytes, we can normally assume that the electric permittivity is constant and equal to a bulk value:

$$\mathbf{D} = \varepsilon_0 \varepsilon_s \mathbf{E} = -\varepsilon_0 \varepsilon_s \nabla V$$

Hence

$$\nabla^2 V + \frac{\rho_v}{\varepsilon_0 \varepsilon_s} = 0$$

In an electrolyte with ionic charge carriers, the charge density can be written as:

$$\rho_v = F \sum_i z_i c_i$$

Hence

$$\nabla^2 V + \frac{F}{\varepsilon_0 \varepsilon_s} \sum_i z_i c_i = 0$$

This is the *Poisson equation* relating the electrolyte potential to the distribution of charge carriers within the electrolyte. In its derivation we assumed that the only charge carriers are ions, and that the solvated ions and electric field do not alter the permittivity of the medium.

The mass transport of the charge carriers in aqueous systems is normally given by the *Nernst-Planck equations*. These equations neglect ion-ion interactions, and so they are only exact for infinitely dilute solutions:

$$\mathbf{N}_i = -D_i \nabla c_i - z_i u_{m,i} F c_i \nabla \phi_l + c_i \mathbf{u}$$

Note that concentrated electrolyte systems, such as those in many batteries, use an extended concentrated species flux definition, based on the Maxwell-Stefan set of

equations. This will result in a different set of equations to solve for, but the general principles and conclusion in this section will be the same.

Substituting the Nernst–Einstein relation for the electrical mobility of an ion we get:

$$\mathbf{N}_i = -D_i \left( \nabla c_i + \frac{z_i F}{RT} c_i \nabla \phi_l \right) + c_i \mathbf{u}$$

The above expressions for the  $n$  species  $i$ , together with the Poisson equation, give a set of  $n + 1$  equations in  $n + 1$  unknowns. These are the *Nernst–Planck–Poisson equations*. They can be defined in COMSOL Multiphysics by coupling **Transport of Diluted Species** with **Electrostatics**, or by using the **Tertiary Current Distribution, Nernst–Planck** interface with **Charge conservation model: Poisson**, but they are highly nonlinear and difficult to converge. Most often, further approximations can simplify the problem without compromising accuracy.



- [Theory for the Transport of Diluted Species Interface](#)
- [Theory of Electrostatics](#) in the *COMSOL Multiphysics Reference Manual*

An important dimensional quantity occurring in the Poisson equation is:

$$x_D = \sqrt{\frac{RT \epsilon_0 \epsilon_s}{F^2 I}}$$

This is the length across which electric fields are screened. It is called the *Debye length*. This is a very short length in electrolyte solutions: for a typical ionic strength, it is of the order of 1 nm. *Electroneutrality* holds at distances much larger than 1 nm from a charged surface:

$$\sum z_i c_i = 0$$

The constraint of electroneutrality can be used as a condition to determine the electric potential in the Nernst–Planck equations, in place of the full Poisson equation. The

Nernst–Planck equations with electroneutrality are used to describe current flow in the **Tertiary Current Distribution, Nernst–Planck** interface.



## The Tertiary Current Distribution, Nernst–Planck Interface

The current flow itself is given by

$$\mathbf{i}_l = F \sum z_i \mathbf{N}_i$$

From substitution of the Nernst–Planck expressions for  $\mathbf{N}_i$ , the laws of conservation of mass and charge combine to automatically satisfy conservation of current.

We can simplify the system further by considering the arising expression for  $\mathbf{i}_l$  in more detail:

$$\mathbf{i}_l = -F \sum D_i z_i \nabla c_i - \frac{F^2}{RT} \nabla \phi_l \sum z_i^2 D_i c_i + \mathbf{u} \sum z_i c_i$$

Clearly, the rightmost term is zero: that is, convection of an electroneutral solution does not cause current flow. The leftmost term (diffusion current) also vanishes due to electroneutrality if the gradients of the charge carrying species are zero.

Even if this is not the case, however, this term is often much smaller than the central term (migration current), so long as the concentrations of the current-carrying ions do not vary markedly through the solution. Under conditions where the composition of the electrolyte can be considered nearly constant and current-carrying ions are not significantly depleted, the diffusion current can be assumed to contribute negligibly.

Hence, it follows that

$$\mathbf{i}_l = -\sigma_l \nabla \phi_l$$

This expression for current density is used in the **Secondary Current Distribution** interface, and also the **Primary Current Distribution** interface. The difference between these interfaces lies in the treatment of the electrode-electrolyte interfaces (see [Kinetics of Electrochemical Reactions](#) below). From the above, the conductivity of the electrolyte  $\sigma_l$  is given as:

$$\sigma_l = \frac{F^2}{RT} \sum z_i^2 D_i c_i$$

So long as this quantity does not vary markedly through the solution, the approximation of zero diffusion current is good. If the diffusivities and concentrations can be taken as constant, we can approximate that:

$$\sigma_l \approx \frac{2F^2 ID_{\text{mean}}}{RT}$$

The advantage of the ohmic expression for current density is that it is a linear relation of current density to electrolyte potential. It is only weakly nonlinear if  $\sigma_l$  is allowed to depend on a concentration solved for in a species transport interface. By comparison, the Nernst–Planck equations with electroneutrality can be highly nonlinear.

The approximations used to derive the secondary current distribution expression place tighter constraints on the allowed system configurations, however. The ionic strength of the solution must remain near-constant for the constant conductivity approximation to be valid. Usually this is only the case for relatively high conductivity solutions.

When the conductivity is large with respect to the current drawn, the electric field becomes negligible in solution. For negligible electric fields, a diffusion-only approximation may be used, where  $\mathbf{E} = \mathbf{0}$ . This converts the Nernst–Planck equations into Fick’s laws, with a term for convective transport where necessary. Fick’s laws with convection and electrochemical boundary conditions are solved for in the **Electroanalysis** interface.



Even if you think a problem will involve the full Nernst–Planck equations, it is best to set the model up in **Secondary Current Distribution** first, in order to identify any other possible complications in the system while using a simpler electrochemical model.

---



Theory for the Current Distribution Interfaces

---

### *Modeling Electrochemical Reactions*

---

Electrochemical reactions are defined by using **Electrode Reaction** or **Porous Electrode Reaction** nodes. An electrode reaction is defined by its thermodynamics, kinetics, and stoichiometry. The latter describes the mass fluxes, sources, and sinks arising due to a certain current density of the reaction.

## THERMODYNAMICS OF ELECTROCHEMICAL REACTIONS

An electrolytic reaction involves the exchange of electrons with the electrode. Such a reaction is written as reduction, even if the reaction occurs predominantly in the oxidative direction. For example:

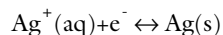

This reaction is called a “half-cell” reaction, since it will occur at a specific electrode-electrolyte interface. It cannot occur in isolation, but only when coupled to another half-cell reaction within a two-electrode electrochemical cell. Each reaction has a characteristic Gibbs energy change that determines whether or not it is thermodynamically favorable. A negative Gibbs energy change means that the reaction proceeds spontaneously — it is thermodynamically “downhill”.

The Gibbs energy change is related to the equilibrium potential difference from the electrode to the electrolyte according to:

$$E_{\text{eq}, m} = -\frac{\Delta G_m}{n_m F}$$

where  $E_{\text{eq}, m}$  is the potential difference on some external reference scale for which the reaction is at equilibrium ( $\Delta G = 0$ ). This is called the *equilibrium potential* or *reduction potential* (or in corrosion, *corrosion potential*) of the electrochemical reaction, and its absolute value depends on the choice of reference electrode.



---

Equilibrium potentials should always be quoted versus a specific reference. If a different reference scale is used in different parts of your model, the thermodynamics of the system may not behave as expected.

---

From the standard thermodynamic relation

$$\Delta G = -RT \ln K$$

it follows that

$$E - E_{\text{eq}} = \frac{RT}{nF} \ln K$$

This is the Nernst equation which is a universal thermodynamic expression. It is always true of systems at thermodynamic equilibrium; it does not necessarily apply to systems not at equilibrium.

Assuming that the species are ideal and that activity effects can be treated as constant, then for the conversion between unimolecular reduced and oxidized species:

$$[\text{Ox}] = [\text{Red}] \exp\left(\frac{nF}{RT}(\phi_s - \phi_l - E_f)\right)$$

Hence at *equilibrium*, the concentrations of reactants and products at the *electrolyte-electrode surface* are related by an expression which depends on the potential difference between the two phases, and two reaction parameters:  $n$ , the number of electrons transferred per molecule reduced; and  $E_f$ , the formal reduction potential of the reaction measured on the same potential scale as the electrode-electrolyte potential difference.

The quantity

$$\eta_m = \phi_s - \phi_l - E_{\text{eq},m}$$

is known as the *overpotential* and is particular to a specific reaction occurring at the interface.



$\eta_m$  depends on both the electric potential in the electrode  $\phi_s$  and the electrolyte potential  $\phi_l$ . Where there is substantial resistance to current flow through a solution, the corresponding potential difference in  $\phi_l$  called *ohmic drop*, alters the position of the electrochemical equilibrium. Additional applied potential in the electrical circuit may then be needed to drive an equivalent overpotential.

## KINETICS OF ELECTROCHEMICAL REACTIONS

The Nernst equation tells us the position of equilibrium of a reaction. However, it tells us nothing about how fast the system may get there. If there is a kinetic limitation — that is, if the reaction proceeds slowly — the equilibrium condition may never be observed. As a familiar example, diamond is thermodynamically unstable with respect to reacting to form graphite at room temperature and pressure. However, this reaction is kinetically limited by a vast activation energy for the reorientation of atoms, such that it is never in practice observed, and diamond is technically described as *metastable*.

We encounter the same issue in many electrochemical contexts. Reactions are prevented from proceeding to their equilibrium by kinetic limitations. Indeed, overcoming the natural kinetic sluggishness of the surface reactions of small, nonpolar molecules such as hydrogen and oxygen is key to much fuel cell research.

There are two important expressions describing the current density due to an electrochemical reaction as a function of the overpotential and the concentrations of reactant and product. It should be noted that the validity of these expressions is not general and can never replace experimental kinetic data if such is available.

The first is the *Tafel law* which describes an irreversible anodic or cathodic process:

$$\log\left(\frac{i}{i_0}\right) = A\eta$$

The constant  $A$  is the *Tafel slope* and has units  $1/V$ . It is usually close to a half-integer multiple of  $F/RT$  and is less than or equal to  $nF/RT$ . Note that a reference *exchange current density*  $i_0$  must be specified for the reaction. This is by definition the current density drawn at zero overpotential.



The Tafel law assumes that a reaction is irreversible. If the reverse reaction might occur in practice, Tafel kinetics will not be correct.

---

The second expression is the *Butler–Volmer equation*, which describes a reversible process, so that either anodic or cathodic current may flow depending on the sign and magnitude of the overpotential:

$$i = i_0 \left( \exp\left(\frac{\alpha_a F \eta}{RT}\right) - \exp\left(\frac{-\alpha_c F \eta}{RT}\right) \right)$$



The Butler–Volmer equation is the most general description of electrode kinetics. It is highly adaptable because:

- $i_0$  is an empirical quantity.
- It agrees with the Nernst equation when  $i = 0$ , so for a very fast reaction ( $i_0 \rightarrow \infty$ ) then the Butler–Volmer equation gives the same potential difference as the Nernst equation. This is equally true under high resistance conditions.
- It agrees with the Tafel equation when either the anodic or cathodic term dominates. For highly irreversible reactions (very low  $i_0$ ), appreciable current is only drawn for large overpotential, so this is typically the case.

For a discussion on the Butler–Volmer expression and concentration changes of the participating species, see the [Defining Concentration Dependent Butler–Volmer Kinetics](#) section below.

For a reversible reaction at very low overpotential ( $\eta$  of order  $RT/F \sim 25$  mV), the exponentials in the Butler–Volmer equation can be linearized:

$$i_{\text{loc}} = i_0 \left( \frac{(\alpha_a + \alpha_c)F}{RT} \right) \eta$$

	Using a linearized Butler–Volmer reaction can be advantageous when investigating convergence issues of a model.
	The linearized Butler–Volmer equation is not correct for applied overpotentials larger than $(RT/F)$ . This is about 25 mV at room temperature. It is not suitable outside this range and therefore its use is confined to electrochemical processes occurring exclusively at low current density, such as electroplating or electrochemical impedance spectroscopy.
	Electrode Kinetics Expressions

### FLUXES AND SOURCES/SINKS DUE TO ELECTRODE REACTIONS

Electrode reactions will result in a molecular flux of reacting species to or from the electrode surface. If you are including mass transport in your model it is common to couple the flux of a reacting species on a boundary to the electrode reaction current density (by the Faraday’s law of electrolysis).



The coupling of chemical flux to electric current density is automated in some of the Electrochemistry interfaces by defining the reaction stoichiometry in the **Electrode Reaction** and **Porous Electrode Reaction** nodes. In the Chemical species transport interfaces the coupling however needs to be set up manually by the [Electrode Surface Coupling](#) nodes. When modeling porous electrodes, the corresponding coupling node to create a source/sink in a domain is the [Porous Electrode Coupling](#) node.

The mathematical treatment can be summed up by the expression:

$$N_j = -\frac{\nu_j m i_m}{n_m F}$$

This means that the flux  $N_j$  of chemical species  $j$  into the surface is proportional to the current density  $i_m$  due to reaction  $m$  drawn at an electrode-electrolyte interface. The constant of proportionality is the stoichiometric number for the species divided by  $n_m$ , the number of electrons transferred in reaction  $m$ , in a reductive direction and  $F$  the Faraday constant (96,485 C/mol, the absolute charge on a mole of electrons).

As such, knowledge of the stoichiometry of an electrochemical reaction allows the local flux of a chemical species to be coupled to the current density contributed by that reaction. Note that multiple reactions may take place simultaneously at an electrode, and their contributions to the current density are simply summed.

	The stoichiometric coefficients of the chemical species in an electrochemical reaction are conventionally written with the forward reaction in the direction of reduction, even if in practice within the system the reaction predominantly proceeds in the other direction.
	COMSOL Multiphysics uses the standard convention that anodic (oxidative) current is positive. Cathodic (reductive) current is negative.

### DEFINING CONCENTRATION DEPENDENT BUTLER-VOLMER KINETICS

If the concentrations at an electrode surface change, this will have an impact on the local kinetics. The Butler-Volmer kinetics expression is derived by considering the rate of a redox reaction



as the sum of the forward and backward rates according to:

$$r = \frac{i_{\text{loc}}}{nF} = k_{\text{fwd}} c_R \exp\left(\frac{\alpha_a F E}{RT}\right) - k_{\text{rwd}} c_O \exp\left(-\frac{\alpha_c F E}{RT}\right) \quad (2-2)$$

where  $k_{\text{fwd}}$  and  $k_{\text{rwd}}$  are reaction rate constants and  $c_O$  and  $c_R$  are the activities of the oxidized and reduced species of the redox couple, respectively. The potential  $E$  is here defined as

$$E = \phi_s - \phi_l \quad (2-3)$$

and the transfer coefficients are equal the sum of electrons in the charge transfer reaction according to

$$\alpha_a + \alpha_c = n \quad (2-4)$$

By defining an equilibrium potential at which the forward reaction and backward reaction rates are equal, Equation 2-1 can be shown to be equivalent to the commonly used Butler–Volmer equation:

$$i_{\text{loc}} = i_0 \left( \exp\left(\frac{\alpha_a F \eta}{RT}\right) - \exp\left(-\frac{\alpha_c F \eta}{RT}\right) \right) \quad (2-5)$$

In this formulation, assuming the stoichiometric coefficients of the oxidized and reduced species to be  $-1$  and  $1$ , respectively, the exchange current density,  $i_0$ , is defined as:

$$i_0 = i_{0, \text{ref}} \frac{c_R}{c_{R, \text{ref}}}^{\alpha_c/n} \frac{c_O}{c_{O, \text{ref}}}^{\alpha_a/n} \quad (2-6)$$

where  $i_{0, \text{ref}}$  is the exchange current density at some chosen reference conditions, and the overpotential is defined as

$$\eta = E - E_{\text{eq}} \quad (2-7)$$

where  $E_{\text{eq}}$  is the equilibrium potential is defined by the Nernst equation as

$$E_{\text{eq}} = E_{\text{eq, ref}} - \frac{RT}{nF} \ln \frac{c_R/c_{R, \text{ref}}}{c_O/c_{O, \text{ref}}} \quad (2-8)$$

and  $E_{\text{eq, ref}}$  is the equilibrium potential at the same reference conditions.

Typically standard conditions are used as reference concentrations, for instance concentrations of 1 M for ions in aqueous solutions.

Note that in Equation 2-5 both  $i_0$  and  $E_{\text{eq}}$  are concentration dependent. This has some numerical drawbacks when modeling electrochemical cells including mass transport, since for low concentrations of the participating species (that is, when  $c_O \rightarrow 0$  or  $c_R \rightarrow 0$ ), the factor  $\ln(c_R/c_O)$  may become undefined during the solution process. An expression of the form of Equation 2-2 is more desirable since this expressions contains a simple linear dependence on the species activities.

A common solution to this issue is to rewrite the Butler–Volmer expression by defining the overpotential with respect to a fixed reference state for the activities  $c_{R, \text{ref}}$  and  $c_{O, \text{ref}}$  (typically corresponding to the inlet or initial concentrations), resulting in

$$i_{\text{loc}} = i_{0, \text{ref}} \left( \frac{c_R}{c_{R, \text{ref}}} \exp\left(\frac{\alpha_a F \eta_{\text{ref}}}{RT}\right) - \frac{c_O}{c_{O, \text{ref}}} \exp\left(-\frac{\alpha_c F \eta_{\text{ref}}}{RT}\right) \right) \quad (2-9)$$

where

$$\eta_{\text{ref}} = E - E_{\text{eq,ref}} \quad (2-10)$$

Note that [Equation 2-9](#) now contains a linear dependence on the activities  $c_O$  and  $c_R$ .

### *Double Layer Capacitance*

---

The Tafel and Butler–Volmer expressions can be used to calculate the magnitude of the current due to electrolysis: this is called *faradaic current*. However, the electrode-electrolyte interface may also draw capacitive current due to the attraction or repulsion of ions creating an oppositely charged layer of ions to form in solution close to the electrode.

The layer of charge on the electrode and layer of opposite charge in the adjacent electrolyte is called the *double layer* and can be thought of as behaving like a parallel plate capacitor, since the absolute amount of charge it separates varies with the charge density on the electrode, and hence with its voltage. The physics of double layer structure and formation are highly complex and are not yet well understood. One of the simplest empirical methods to account for the observed influence of capacitance on polarization curves is to introduce a constant ideal capacitance across the electrode-electrolyte interface.

This effect can be added to via the **Double Layer Capacitance** condition. The capacitor stores a surface charge density  $Q = C_d(\phi_s - \phi_l)$ , and contributes a dynamic charging current density (*nonfaradaic current*) equal to  $i_{\text{NF}} = dQ/dt$ . The total current recorded in a real experiment equals:

$$i_{\text{tot}} = i_{\text{Far}} + i_{\text{NF}}$$

Sometimes in electroanalysis a blank scan with no electrolysis is run to subtract nonfaradaic current. If double layer capacitance is ignored in your model, you should

make sure that you are comparing it to experimental data recorded under the same conditions.



The ability of COMSOL Multiphysics to model electrostatics and transport of charged species make it tempting to incorporate the double layer explicitly to add more detail to a model. These coupled equations are always extremely nonlinear and convergence is not trivial except in the simplest cases. Although the diffuse double layer can be modeled in isolation (see example), this is not recommended in conjunction with a fuller electrochemical model.



## Double-Layer Capacitance



### *Porous Electrodes*

A porous electrode is one in which the three-dimensional structure of the electrode is permeable to electrolyte. The electrode-electrolyte interface then extends over a much larger surface area. This specific surface area (“SSA”, area per unit volume, units  $1/m$ ) is a key property of a porous electrode. Additionally, such an electrode can conduct electric current independently through its electrode and electrolyte domains.

Most electrochemical interfaces in COMSOL Multiphysics include **Porous Electrode** domain nodes that can be used to model the above situation. In a **Porous Electrode**, current density is carried in both the electrode and in the pores which are assumed to contain electrolyte. For gas diffusion electrodes where the solid is conducting but the pore phase is not, the **Electrode** condition should be used.

It is common to combine an electrochemical interface with other physics, in order to model the mass transport, heat transfer and flow properties of a porous medium. For

instance, **Secondary Current Distribution** might be coupled to **Transport of Diluted Species in Porous Media**, **Heat Transfer in Porous Media**, and **Darcy's Law**.

	Homogenized transport parameters such as diffusion coefficients are commonly obtained for a bulk solution of the material. In porous media these must be corrected for tortuosity and porosity. Carefully consider such effects when defining your material properties.
	<a href="#">Porous Electrode Theory</a>

---

### *Boundary Conditions for Running and Controlling Electrochemical Cells*

---

An electrochemical cell is typically operated by controlling either the cell voltage (potentiostatic control) or the cell current (galvanostatic control). In a lab experiment this is accomplished by using a potentiostat.

In a model, potentiostatic control is defined by using fixed potential boundary conditions. This can be done by setting the **Electric Potential** with respect to ground to control the cell potential, or the **Electrode Potential** with respect to a reference potential somewhere in the system. Galvanostatic control can be accomplished using **Total Current** or **Average Current Density** boundary conditions. For both cases, one electrode in the cell needs to be grounded.

Mathematically, a **Total Current** or **Average Current Density** condition implies setting the potential of a boundary to be equal to an additional extra global potential degree of freedom (floating potential) to comply with the specified current condition. For this reason, solving for galvanic control is numerically slightly more complex.

Note that explicitly prescribing the current density distribution on an electrode boundary is hard to accomplish in a real world experiment. In higher dimensions than 1D, **Electrode Current Density** and **Electrolyte Current Density** boundary conditions should be used with care.

#### **SHORT-CIRCUITING A CELL AND GALVANIC CORROSION**

The simplest way to model a short-circuited cell is to set both electrodes to the same (electronic) potential, using a fixed potential boundary condition. The charge balance

equation of the electrolyte will make sure the total current over all electrode surfaces sums up to zero.

Note that many galvanic corrosion situations are practically equivalent to a short circuit of two electrodes consisting of different metals. In such models, the two metals are set to the same potential. Usually this potential is chosen to be zero (ground).



- [Electrode Potential](#)
  - [Reference Electrode](#)
- 

### *Modeling Cyclic Voltammetry*

---

In a cyclic voltammetry experiment, a potentiostat is used to sweep the voltage at the working electrode linearly from a start potential to a vertex potential, and back again. Typically, the potential window is chosen to span the formal potential of a redox couple of interest, allowing both the kinetics and transport properties of the chemical species to be investigated. The target species reacts under kinetic control to the point of depletion where the current becomes transport-controlled.

The built-in **Cyclic Voltammetry** study step in the **Electroanalysis** interface can be used to automatically set up the voltage sweep in a time-dependent study.

### *Common Simplifications When Modeling Electrochemical Cells*

---

#### **SHOULD I MODEL IN 3D OR CAN I MODEL IN 1D?**

Many electrochemical systems use repetitive unit cells of high aspect ratio. In these cases, the lumped effect of edge phenomena in the system will be small. For example, in fuel cells or batteries it is often possible to use one-dimensional geometries with little loss of detail. Consider also any mirror or rotational symmetries. Reducing the geometry dimension where possible, either exactly or approximately, will reduce the meshing and solving time significantly.



Starting with a 1D model helps to understand the influence of different reactions and phenomena in an electrochemical system, and gives a good first estimate of current-voltage behavior.

---

## NEGLECTING THE CHARGE TRANSFER AND POTENTIAL GRADIENTS IN ELECTRODES

The voltage over the surface of an electrode is typically constant — or very nearly constant — since it is a good conductor. This implies that it is either the intrinsic resistance of the electrolyte or the rate of the electrochemical reaction at the electrode-electrolyte interface that controls the amount of current drawn in an electrochemical cell. On the assumption of a constant surface voltage, the electrode domain itself need not be modeled, and the coupling of charge and mass transport at its surface treated by an **Electrode Surface** node.



### Electrode Surface

---

However, when modeling porous and gas diffusion electrodes the metal phase potential is need typically to be included since the conductivity of the metal phase potential can be much lower in this type of electrodes. This is done in the **Porous Electrode** nodes.

## HALF-CELL MODELS

Often, an investigator is only interested in the chemistry taking place at one electrode in a cell. A model of one electrode is called a “half-cell model”.

This would correspond to an experimental situation where the electrode of interest — be it anode or cathode — is classified as the *working electrode*, and the other electrode is called the *counter electrode*.

One usually ignores the kinetics of the counter electrode in a model; commonly it is represented by a constant potential boundary condition. Such a model is only valid if the counter electrode can draw arbitrarily large amounts of current compared to the working electrode, so that it never limits the current flow in the electrochemical cell.

## REPLACING THIN LAYERS WITH BOUNDARY CONDITIONS

When considering a layer that is very thin compared to other dimensions in the geometry, it is usually correct to treat that layer using a physical condition, rather than meshing it.

One important example is the catalyst layer in a fuel cell. Since this layer is only nanometers in size, transport across it is very fast compared to other parts of the

system. Hence, it is not necessary to resolve a distribution of concentrations or potentials through the layer.

Another example is the passivation layer on an oxidized electrode surface, for which the “Thin Film Resistance” setting can be used. Because the layer is much thinner than its surroundings, the electric field through it is almost constant. Therefore, an ohmic expression can be substituted to create a boundary condition with a potential drop. This is much more efficient than meshing a geometrically narrow layer.



Film Resistance

---

### **INFINITE ELEMENTS FOR STEADY-STATE ELECTROANALYSIS**

For microelectrodes, the diffusion profile may approach a steady state whose size is much larger than that of the working electrode of interest. In such an example, it is preferable to circumscribe the simulation space to a region not more than about twenty-five times the electrode size - assuming that the surrounding electrolyte is uniform. Applying a bulk boundary condition such as a fixed concentration at this finite distance causes inaccuracy in the solution, however.

It is better to use a layer of **Infinite Elements** around the finite simulation space to project the simulation space to infinity, eliminating any error from artificially limiting the simulation space. This is a typical approximation when the electrolyte domain is a few orders of magnitude larger than the electrode: for example, a microelectrode in a cm-scale reaction vessel.



Infinite Elements, Perfectly Matched Layers, and Absorbing Layers in the *COMSOL Multiphysics Reference Manual*

---

*Before You Start Building Your Model*

---

### **INTRODUCING COMPLEXITY ONE STEP AT A TIME**

The true art of modeling is knowing what phenomena to include and what phenomena to neglect. Building complexity in a model by adding one additional piece of physics

or geometric feature at a time is usually the fastest way to reach the modeling goal. Here are some general tips:

- Start thinking about your cell in the lowest possible dimension. Starting with a 1D model helps to understand the influence of different reactions in an electrochemical system, and gives a good first estimate of current-voltage behavior. Go from 1D to 2D, then from 2D to 3D.
- Every electrode reaction adds numerical nonlinearities to your model. If you have multiple electrode reactions, add them one at a time.
- Start with a simple description of the electrolyte current, such as **Secondary Current Distribution**. Analyze the results to ensure that the electrochemical model is consistent. Switch only to more complex electrolyte models, or add extra physics such as mass transfer, heat transfer or flow, only if deemed necessary and when satisfied with the results from a simpler case.
- If you are including flow in your model, solve for the flow field first before coupling flow and electrochemistry together.

#### **MODELING CHECKLIST**

- Identify which domains are electrode and electrolyte. How will their conductivity be assessed?
- What is happening on the electrode-electrolyte interfaces? Do both the anode and the cathode need to be modeled? Do either need to be modeled as domains, or can they be treated as boundaries?
- What electrochemical reactions take place at the electrode surfaces to cause charge transfer? Can you parameterize their thermodynamics? Do you know the equilibrium potentials? Can you parameterize their kinetics — and are the kinetics ever going to be important? If not, ignore them.
- What is the system reference potential used to quote equilibrium potentials? Where is the system ground?
- Are charge carriers in the electrolyte plentiful with respect to the drawn current density, or is charge depletion important? Be aware of nonlinear effects that may make convergence more difficult.
- If you are performing a time-dependent study, do your initial conditions have a consistent current-voltage relationship?
- What other physics interfaces need to be coupled? How does charge transfer influence these physics interfaces?

## *Meshing Advice*

---

The default triangular (2D) or tetrahedral (3D) mesh is normally suitable for solving the equations describing conservation of charge and mass for a general electrochemical problem.

Electrochemical models involving mass transport generally benefit from a finer mesh at the electrode surfaces, and at singularities such as the boundary between an electrode surface and an insulating surface. This may be accomplished by adding additional **Size** mesh nodes for these boundaries only. Also, consider refining the “element growth rate”, and/or using boundary layer meshing in 3D.

Sometimes, a regular **Mapped** mesh can be more appropriate in a rectangular (2D) domain; such domains are common in cutaway schematic studies of batteries and fuel cells. Similarly the **Swept** mesh is often appropriate for very thin layers in a 3D model.

For fluid domains, the default physics-controlled mesh should be used, with boundary layers as required.

For some problems with a stationary flow velocity field and time-dependent convection of electrochemically reacting species, it may improve convergence to set up a refined mesh without boundary layers for the species transport study step.



Meshing in the *COMSOL Multiphysics Reference Manual*

---

## *Solving Electrochemical Models*

---

Due to the highly nonlinear nature of electrode kinetics, some electrochemical models can be difficult to solve. This section includes some general tips and tricks to facilitate model solving, trouble shooting, and to improve solution accuracy.

### **GENERAL CURRENT DISTRIBUTION PROBLEMS**

Start with the following suggestions if you encounter difficulty solving a problem.

- Make sure that the potential levels are “boot-strapped” somewhere in the model, preferably by grounding one electrode. If there is no potential level defined anywhere in the model, your model may have infinitely many solutions, and the model will not converge.

- Consider using a **Stationary with Initialization** or a **Time Dependent with Initialization** study. Both these studies will use a **Current Distribution Initialization** study step as a first step to solve for the potentials only. If you run into problems solving for the second step in this study you may have to change the “Current distribution type” setting to **Secondary** on the **Current Distribution Initialization** study step node, and also review the **Initial Values** as described in the next bullet.
- Review the **Initial Values**, especially the potentials. Suitable initial potential values can usually be derived making a “potential walk” through the geometry, starting at the grounded boundary. Compute electric and electrolyte potentials in other domains by assuming equilibrium potential differences between electrode and electrolyte for the main electrode reactions.
- Switch to **Linearized Butler–Volmer** kinetics (or a **Primary** current distribution) while troubleshooting. This can be useful to help achieve a solution for a model that does not solve with nonlinear kinetics, thereby indicating suitable initial values for the nonlinear problem.
- If your model contains porous electrodes, try refining the mesh resolution in these domains, especially toward the electrolyte boundaries.



- [Electrochemistry Interfaces](#)
- [Specifying Initial Values and Inspecting and Troubleshooting Meshes](#) in the *COMSOL Multiphysics Reference Manual*

## ELECTROCHEMISTRY COUPLED TO MASS TRANSPORT

If the model involves electrochemistry coupled to mass transport, here are a few things to try to help improve model convergence.

- Review the **Initial Values** for the concentration values. Zero initial concentration values can be unsuitable for tertiary current distribution problems and battery simulations, since they could imply that no charge carriers or no reacting material is present.
- If steep concentration gradients are expected close to electrode surfaces, use boundary layer meshing or finer mesh **Size** settings at these boundaries.
- When setting up user-defined kinetics expressions, avoid evaluating negative concentrations by using expressions such as  $\max(c, \text{eps}^2)$ , where **eps** is the machine epsilon (a very small but finite number).

- Try to solve for low currents and low overpotentials first, then increase the cell load (for stationary problems this can be done using an auxiliary sweep with continuation).
- If a problem involving mass transport is hard to solve for high currents, but solves for low currents, it might be due to mass transport limitations. In this case, review the transport parameter values and check that the current magnitudes are reasonable. If the current densities are unreasonably high, review the electrode reaction settings.
- For time-dependent problems that run into convergence problems after a certain time, review the solution at the last time-step. If the solution of a reactant reaches zero or a maximum value (for insertion electrodes in batteries) when the convergence issues occur, the current load of the model is too high in relation to your initial concentrations or mass transport properties.



- [Electrochemistry Interfaces](#)

In the *COMSOL Multiphysics Reference Manual*:

- [2D and 3D Boundary Layer Meshes](#)
- [Stationary and Parametric Sweep](#)

## SETTING UP A STUDY SEQUENCE FOR MULTIPHYSICS PROBLEMS

For multiphysics problems, try to adjust the study sequence.

- Solve certain physics interfaces in a sequence. This can in many cases reduce computational time and improve convergence. Analyzing the results when solving a physics interface separately can also help when troubleshooting a nonconverging model.
- A good strategy is often to solve for the potentials only (that is, disable mass transport and flow interfaces), using a stationary study step, before solving the full model in the study sequence. In this way the stationary solution is used as initial values for the following steps. This can be manually by modifying the settings of the study node, or in an automated way by using the **Stationary with Initialization** or **Time Dependent with Initialization** study sequences, as described above.
- In many models the flow profile is only slightly (or not at all) affected by changes in current density. Therefore it can be a good strategy to solve separately for the flow early in the study sequence, and then solve for the other physics interfaces in the

subsequent steps. (If the flow is not affected at all by the current distribution, solving for the flow can be disabled entirely in consecutive steps.)

- 
- [Electrochemistry Interfaces](#)

In the *COMSOL Multiphysics Reference Manual*:



- [Studies and Solvers](#)
  - [Analyzing Model Convergence and Accuracy](#)
  - [Achieving Convergence When Solving Nonlinear Equations](#)
- 

### TIME-DEPENDENT PROBLEMS WITH LOAD STEPS

For time-dependent problems, try the following to address accuracy and convergence issues with regards to sudden current or potential load steps.

- Use smoothed current or potential load functions in order to avoid instantaneous or discrete load steps.
- Add a double layer capacitance to the model, which can improve the numerical stability.
- Reduce the **Maximum step** taken by the solver if you want to prevent the solver from “missing” short square load steps, or change the **Steps taken by solver** setting from **Free** to **Strict**, or **Intermediate**, to control the time steps using the **Times** text field. Using the Events interface can also be an option in certain cases if the load cycle itself varies dynamically.

- 
- [Double-Layer Capacitance](#)

In the *COMSOL Multiphysics Reference Manual*:



- [Step and Time Dependent](#)
  - [Building a COMSOL Multiphysics Model and The Events Interface](#)
- 

### SOLVER SETTINGS

Try adjusting the solver settings.

- In rare cases, try to increase the **Maximum number of iterations**.
- If you know the order of magnitude of the dependent variables beforehand, setting the scaling method to **Manual** for these can improve convergence and the accuracy of the results. This may be of special importance when solving for concentrations

that are initially very small but where the final order of magnitude is known *a priori*. This could be the case for the active species in a battery model, for example.



In the *COMSOL Multiphysics Reference Manual*:

- [Studies and Solvers](#)
- [Analyzing Model Convergence and Accuracy](#)
- [Achieving Convergence When Solving Nonlinear Equations](#)



[Electrochemistry Studies and Study Steps](#) and [Cyclic Voltammetry](#) in the *COMSOL Multiphysics Reference Manual*



In multicomponent systems it is rarely straightforward to predict the rest potential and direction of current flow. The **Current Initialization** step in COMSOL Multiphysics does this for you but is only correct if concentrations and formal potentials for all electrode reactions are specified precisely and with respect to a common reference scale.



[Electrochemistry Studies and Study Steps](#) in the *COMSOL Multiphysics Reference Manual*



[Studies and Solvers](#) and [Building a COMSOL Multiphysics Model](#) in the *COMSOL Multiphysics Reference Manual*

### POTENTIAL VARIABLES

Several different potential variables are available for postprocessing and during computation. The most common ones are described in [Table 2-1](#).

TABLE 2-1: COMMON POTENTIAL VARIABLES.

VARIABLE	DESCRIPTION	DEFINED AT
phil	Electrolyte phase potential	Electrolyte and Porous Electrode domains
phis	Electrode phase potential	Electrode and Porous Electrode domains
xxx.phisext	Electrode phase potential	Electrode Reaction boundaries to Electrolyte domains
xxx.Eeq_yy	Equilibrium potential	Electrode Reaction boundaries and Porous Electrode Reaction domains
xxx.eta_yy	Overpotential	Electrode Reaction boundaries

The unit is V for all the above variables.

xxx denotes the tag of the physics interface. For instance, cd for the Secondary Current Distribution interface.

yy denotes the tag of the (Porous) Electrode Reaction node, for instance, er1 for an Electrode Reaction node.

### CURRENT VARIABLES AND CALCULATING THE TOTAL CELL CURRENT

The current density may vary between locations on an electrode surface. This effect is very important to understand through modeling because it cannot be directly measured. Experimental measurement can only return the total current drawn at an electrode, although the variation in current density can be inferred by other means.

To calculate the total current in COMSOL Multiphysics, it is necessary to integrate the total drawn current density along the boundary or over the domain of the electrode. Some common current density variables are shown in [Table 2-2](#).

TABLE 2-2: COMMON CURRENT DENSITY VARIABLES.

VARIABLE	UNIT	DESCRIPTION	DEFINED AT
xxx.nll	A/m <sup>2</sup>	Electrolyte current density in normal direction	Boundaries to Electrolyte and Porous Electrode domains
xxx.nls	A/m <sup>2</sup>	Electrode current density in normal direction	Boundaries to Electrolyte and Porous Electrode domains

TABLE 2-2: COMMON CURRENT DENSITY VARIABLES.



VARIABLE	UNIT	DESCRIPTION	DEFINED AT
xxx.iloc_yy	A/m <sup>2</sup>	Local current density of electrode reaction	Electrode Reaction boundaries
xxx.itot	A/m <sup>2</sup>	Total interface current density (local sum of all xxx.iloc_yy)	Electrode Reaction boundaries
xxx.iv_yy	A/m <sup>3</sup>	Volumetric current density of a Porous Electrode Reaction	Porous Electrode domains
xxx.ivtot	A/m <sup>3</sup>	Total volumetric current densities (local sum of all xxx.iv_yy)	Porous Electrode domains
xxx.IIMag	A/m <sup>2</sup>	Electrolyte current density magnitude (L <sup>2</sup> norm)	Electrolyte domains
xxx.IsMag	A/m <sup>2</sup>	Electrode current density magnitude (L <sup>2</sup> norm)	Electrode domains

xxx denotes the tag of the physics interface. For instance **cd** for the Secondary Current Distribution interface.

yy denotes the tag of the (Porous) Electrode Reaction node, For instance **er1** for an Electrode Reaction node.

In 1D or 1D axisymmetric, the electrode is implicitly uniform so you can just multiply by the area of the electrode. In 2D or 2D axisymmetric, compute the appropriate line integral. In 3D, compute the surface integral.

You can also define your own total current variable by using an **Integration** nonlocal coupling across the electroactive boundaries. This variable can also be used during the computation. In 1D axisymmetric and 2D axisymmetric components, make sure to select the **Compute integral in revolved geometry** checkbox.

	In the <i>COMSOL Multiphysics Reference Manual</i> : <ul style="list-style-type: none"> <li>• <a href="#">Nonlocal Couplings and Coupling Operators</a> and <a href="#">Integration</a></li> </ul>
	Avoid evaluating the xxx.IIMag/xxx.IsMag variables on boundaries. These are generally less accurate than the xxx.nll/xxx.nls variables.

# Electrochemistry Interfaces

This chapter describes the physics interfaces found under the **Electrochemistry** branch ()

In this chapter:

- The Primary and Secondary Current Distribution Interfaces
- The Tertiary Current Distribution, Nernst–Planck Interface
- Shared Physics Features in the Current Distribution Interfaces
- The Aqueous Electrolyte Transport Interface
- The Concentrated Electrolyte Transport Interface
- The Electrode, Shell Interface
- The Electroanalysis Model Wizard Entry
- Theory for the Current Distribution Interfaces
- Theory for the Aqueous Electrolyte Transport Interface
- Theory for the Concentrated Electrolyte Transport Interface
- Theory for Electrochemical Heat Sources
- Theory for Electrochemical Power Losses
- Theory for the Electrode, Shell Interface

- Theory for Electroanalysis
- Electrode Potentials and Reference Electrodes
- Solving Electrochemical Models

# The Primary and Secondary Current Distribution Interfaces



In this section:

- [The Primary Current Distribution and Secondary Current Distribution Interfaces](#)
- [Electrolyte](#)
- [Initial Values](#)
- [Porous Electrode](#)
- [Periodic Condition](#)
- [Thin Electrolyte Layer](#)
- [Edge Electrode](#)
- [Electrode Line Current Source](#)
- [Electrolyte Line Current Source](#)
- [Electrode Symmetry Axis Current Source](#)
- [Electrolyte Symmetry Axis Current Source](#)
- [Electrode Point Current Source](#)
- [Electrolyte Point Current Source](#)



Only the physics interface-specific nodes are described here. All other nodes in the Primary Current Distribution and Secondary Current Distribution interfaces are described in [Shared Physics Features in the Current Distribution Interfaces](#)

## *The Primary Current Distribution and Secondary Current Distribution Interfaces*

The **Primary Current Distribution (cd)** interface () and the **Secondary Current Distribution (cd)** interface () are found under the **Electrochemistry** branch () when adding a physics interface.

### *Primary Current Distribution Interface*

The **Primary Current Distribution** interface defines the transport of charged ions in an electrolyte of uniform composition as well as current conduction in electrodes using Ohm's law in combination with a charge balance. The physics interface neglects activation overpotentials due to charge transfer reactions.

Use this physics interface to estimate the ohmic losses in simplified models of electrochemical cells, where the overpotentials of the electrode reactions are small compared to the ohmic voltage drops in the electrolyte and electrodes.

#### *Secondary Current Distribution Interface*

The **Secondary Current Distribution** interface is similar to the Primary Current Distribution interface, except that it also accounts for activation overpotentials. The relation between charge transfer and overpotential can be described using arbitrary kinetic expressions, such as Butler–Volmer and Tafel equations.

Use this physics interface for generic modeling of electrochemical cells. It can be combined with interfaces modeling mass transport to describe concentration dependent (tertiary) current distributions.

Use the **Current Distribution Type** setting on the physics interface node, described below, to switch between a Primary Current Distribution and a Secondary Current Distribution interface.



- [Introduction to Electrochemistry Modeling](#)

---

#### **SETTINGS**

The **Label** is the default physics interface name.

The **Name** is used primarily as a scope prefix for variables defined by the physics interface. Refer to such physics interface variables in expressions using the pattern `<name>.<variable_name>`. In order to distinguish between variables belonging to different physics interfaces, the `name` string must be unique. Only letters, numbers, and underscores (`_`) are permitted in the **Name** field. The first character must be a letter.

The default **Name** (for the first physics interface in the model) is `cd`.

#### **DOMAIN SELECTION**



Domains that do not conduct current should be omitted from the Domain Selection: for example, the gas channels in a fuel cell.

---

## OUT-OF-PLANE THICKNESS



For 2D components, enter a value or expression for the out-of-plane **Thickness**  $d$  (SI unit: m). The value of  $d$  determines the size of the domain perpendicular to the modeled 2D cross section. This value yields, for example, the correct total current when the current density is obtained from a 2D simulation.

## CROSS-SECTIONAL AREA



For 1D components, enter a **Cross-sectional area**  $A_c$  (SI unit:  $m^2$ ) to define a parameter for the area of the geometry perpendicular to the 1D component. The value of this parameter is used, among other things, to automatically calculate the total current from the current density vector. The analogy is valid for other fluxes. The default is  $1 m^2$ .

## CURRENT DISTRIBUTION TYPE

The **Current Distribution Type** selected in the list is based on the choice made when adding a physics interface — **Primary** or **Secondary**. The Primary Current Distribution interface changes to a Secondary Current Distribution interface if the choice is changed to **Secondary**, and vice versa.

The selection between **Primary** or **Secondary** governs how electrode reactions are modeled on interfaces between electrodes and electrolytes.

- Models using a **Primary** current distribution type use potential constraints (Dirichlet boundary conditions), according to the equilibrium potential setting.
- **Secondary** current distribution models use current flux conditions (Neumann boundary conditions) according to the sum of all electrode reaction current densities.

## PHYSICS VS. MATERIALS REFERENCE ELECTRODE POTENTIAL

The **Physics vs. Materials Reference Electrode Potential** setting on the physics interface node can be used to combine material library data for current densities and equilibrium potentials with an arbitrary reference electrode scale in the physics. The setting affects the electrode potentials used for model input into the materials node, as well as all equilibrium potential values output from the materials node.

Note that the setting will only impact how potentials are interpreted in communication between the physics and the **Materials** node. If the **From material** option is not in use for equilibrium potentials or electrode kinetics, the setting has no impact.

### DEPENDENT VARIABLES

This physics interface defines dependent variables (fields) for the **Electrolyte potential** and **Electric potential**. The names can be changed but the names of fields and dependent variables must be unique within a model.

### DISCRETIZATION

The interface uses **Linear** elements by default and this setting is recommended for most problems. Certain types of problems, such as models using porous electrodes, or current distribution problems in two dimensions or higher, may benefit in terms of solution accuracy from using **Quadratic** elements.

In multiphysics models it is generally recommended to use the same element order in all coupled interfaces.

To see all settings in this section, click the **Show More Options** button (  ) and select **Advanced Physics Options** in the **Show More Options** dialog.



- [Electrochemical Reactions and the Difference Between a Primary and a Secondary Current Distribution](#)
- [Domain Equations for Primary and Secondary Current Distributions](#)
- [Shared Physics Features in the Current Distribution Interfaces](#)
- [Theory for the Current Distribution Interfaces](#)



Secondary Current Distribution: *Wire Electrode*: Application Library  
path **Electrochemistry\_Module/Electrochemical\_Engineering/wire\_electrode**

### *Electrolyte*

Use the **Electrolyte** node to define an electrolyte domain that only conducts current in the ion conducting phase.

Note that electrolyte in this case does not refer to the pore electrolyte in porous electrodes (which should be defined by a [Porous Electrode](#) node instead).

The **Electrolyte conductivity**,  $\sigma_l$  (SI unit: S/m), parameter will define how the current in the domain depends on the gradient of the potential.



- [Domain Equations for Primary and Secondary Current Distributions](#)
- [Electrolyte Theory](#)

---

### *Initial Values*

---

Use this node to specify the **Initial Values** of the electrolyte potential and the electric potential for the solver.

For many electrochemical problems that use nonlinear electrode kinetics, such as Butler–Volmer kinetics, providing reasonable initial values can significantly improve solver convergence.

A good value for the **Electric potential** (SI unit: V) in electrode and porous electrode domains can usually be derived from the boundary conditions. For instance, if a boundary has been grounded or set to a cell potential, use that value as the initial value also in the adjacent domain. For the **Electrolyte potential** (SI unit: V) a good initial value is often the negative of the equilibrium potential of the grounded electrode.

Note: For **Primary** current distributions, or for models solved using a **Current Distribution Initialization** study step set to **Primary**, the settings of this section usually have limited impact on the solver convergence.

---

### *Porous Electrode*

---

The **Porous Electrode** node sets up charge balances for the electrode and the pore electrolyte in a porous electrode. Note that the node should be used for porous domains that conduct current in both an electrolyte and an electrode phase. For the case of domains that do not contain a pore electrolyte — for instance, a current collector/feeder or a gas diffusion layer (GDL) in a fuel cell — use an [Current Conductor](#) node instead.

Use [Porous Electrode Reaction](#) subnodes to define the charge transfer reactions that occur on the interface between the electrolyte and electrode phases within the porous electrode. For the Secondary Current Distribution interface, the [Porous Matrix Double-Layer Capacitance](#) subnode is also available.

The conductivities are taken **From material** by default. From the respective material list you can use any material in the model, if present. By default they are set to the **Domain material** (which is the material applied to the active domain in the **Materials** node).

You can use the **Effective conductivity correction** factors to account for the lowered effective conductivities of the electrode and electrolyte phases due to the lower volume fractions of each phase, and the tortuosity of the porous matrix.

The **Electrode volume fraction** is used to calculate the effective electric conductivity of the porous matrix when the correction factor is set to **Bruggeman** or **Tortuosity**. Additionally, it is used in calculating the active specific surface area of the porous matrix when **Particle-based area** option is selected in the child nodes.

#### **ADSORBING–DESORBING SPECIES**

See the [Electrode Surface](#) node.

#### **FILM RESISTANCE**

See the [Electrode Surface](#) node.



- [Domain Equations for Primary and Secondary Current Distributions](#)
  - [Porous Electrode Theory](#)
- 

#### *Periodic Condition*

---

Use the **Periodic Condition** to define a periodic relation between two boundaries — for instance, in a model describing a repetitive unit cell.

Use the **Apply for electrolyte phase** and **Apply for electrode phase** checkboxes to enable the periodic condition for the electrolyte and electrode phase potentials, respectively.

By specifying a **Potential difference**, an offset in potential (typically per unit cell) can be prescribed.

For more information, see [Periodic Boundary Conditions](#) in the *COMSOL Multiphysics Reference Manual*.

#### *Thin Electrolyte Layer*

---

The Thin Electrolyte Layer node can be used to model a thin insulating or resistive sheet, located on an interior boundary in an electrolyte domain. The node can be used

as an alternative to drawing the actual layer domain in the model geometry, which may significantly reduce meshing and solver time, especially in 3D models.

Thin insulating sheets are commonly inserted in the electrolyte in various types of electrochemical cells. For example they may be used for optimizing the current distribution in a corrosion protection application, or for optimizing the local deposition rate in a deposition bath.

The layer may be set to be either **Insulating** or **Resistive**.

For the case of **Resistive**, the **Surface Resistance** can either be set directly, or calculated from **Thickness and Conductivity** values.

### ADVANCED SETTINGS

Enable **Slit electric potential in porous electrodes** to make the layer fully insulating for the electrode phase potential along the selected boundaries.

### *Edge Electrode*

---

The **Edge Electrode** can be used in 3D problems to define electrodes such as long pipes and thin wires where the electric potential variation within the electrode in the normal direction to the electrode surface is negligible. This assumption allows for the thin electrode domain to be replaced by a lumped one-dimensional partial differential equation formulation on the edge, describing an electrode surface along the edge with a given **Edge electrode radius**. In this way the problem size can be reduced, and potential problems with mesh anisotropy in the thin layer can be avoided.

The electric current conduction in the tangential direction of an edge can be described by **Ohm's law** or a **Fixed** electric potential or a **Floating potential** assuming infinite conductivity of the edge or an **External short** electric potential which allows to connect two electrodes over an external connector with a given bulk resistance or a **Connection point** electric potential which allows to define a location for connections to other locations in the model.

An Edge Electrode can only be applied to edges within, or adjacent to, [Electrolyte](#) domains.

A default [Electrode Reaction](#) subnode is added by default to the feature. **Double Layer Capacitance**, **External Current Source**, **Electric Ground**, **Electric Potential**, and **Electrode Current** subnodes can also be added to the feature.

### FILM RESISTANCE

See the [Electrode Surface](#) node. The section is only available when a **Secondary** current distribution has been selected on the parent node.

### CONSTRAINT SETTINGS

To display this section, click the **Show More Options** button (  ) and select **Advanced Physics Options** in the **Show More Options** dialog.



The mesh size in the perpendicular direction to the edge should preferably be in the same order of magnitude as the **Edge electrode diameter** in order to achieve good numerical accuracy.

---

### *Electrode Line Current Source*

---



For 3D components, use the **Electrode Line Current Source** on edges.



For 2D components use it on points.



For 2D axisymmetric components, it can only be selected on points outside the symmetry axis.

---

### ELECTRODE CURRENT SOURCE

Enter the **Electrode current source**  $q_{1,s}$  (SI unit: A/m). The default is 0 A/m.

---

### *Electrolyte Line Current Source*

---



For 3D components, use the **Electrolyte Line Current Source** on edges.



For 2D components use it on points.



For 2D axisymmetric components, it can only be selected on points outside the symmetry axis.

---

### ELECTROLYTE CURRENT SOURCE

Enter the **Electrolyte current source**  $q_{1,l}$  (SI unit: A/m). The default is 0 A/m.

### *Electrode Symmetry Axis Current Source*

---



For 2D axisymmetric components apply an **Electrode Symmetry Axis Current Source** along the symmetry axis boundary.

---

#### **ELECTRODE CURRENT SOURCE**

Enter the **Electrode current source**  $q_{1,s}$  (SI unit: A/m). The default is 0 A/m.

### *Electrolyte Symmetry Axis Current Source*

---



For 2D axisymmetric components apply an **Electrolyte Symmetry Axis Current Source** along the symmetry axis boundary.

---

#### **ELECTROLYTE CURRENT SOURCE**

Enter the **Electrolyte current source**  $q_{1,l}$  (SI unit: A/m). The default is 0 A/m.

### *External Current Source*

---

#### **EXTERNAL CURRENT SOURCE**

Enter an **External current source**  $q_{1,s}$  (SI unit: A/m) at the **Edge Electrode**. The default is 0 A/m.

### *Electrode Point Current Source*

---



For 3D components, use the **Electrode Points Current Source** on edges.



For 2D axisymmetric components, it can only be selected on points located on the symmetry axis.

---

#### **ELECTRODE CURRENT SOURCE**

Enter the **Electrode current source**  $q_{p,s}$  (SI unit: A). The default is 0 A.

## *Electrolyte Point Current Source*

---



For 3D components, use the **Electrolyte Points Current Source** on edges.



For 2D axisymmetric components, it can only be selected on points located on the symmetry axis.

---

### **ELECTROLYTE CURRENT SOURCE**

Enter the **Electrolyte current source**  $q_{p,1}$  (SI unit: A). The default is 0 A.

## *Electrode Current*

---

Use this node to define a current source in a point of an Edge Electrode node.

This node is available as a subnode to the **Edge Electrode** node, when **Ohm's Law** has been selected as the electric potential model.

# The Tertiary Current Distribution, Nernst–Planck Interface

In this section:

- [The Tertiary Current Distribution, Nernst–Planck Interface](#)
- [Electrolyte](#)
- [Porous Electrode](#)
- [Separator](#)
- [Reactions](#)
- [Initial Values](#)
- [Ion-Exchange Membrane](#)
- [Ion-Exchange Membrane Boundary](#)
- [Thin Electrolyte Layer](#)

Various nodes are also available and described for the Transport of Diluted Species interface. See [Domain, Boundary, and Pair Nodes for the Transport of Diluted Species Interface](#).





---

All other nodes in the Tertiary Current Distribution, Nernst–Planck interface are described in [Shared Physics Features in the Current Distribution Interfaces](#).

---

## *The Tertiary Current Distribution, Nernst–Planck Interface*

The **Tertiary Current Distribution, Nernst–Planck (tcd)** interface () , found under the **Electrochemistry** branch () when adding a physics interface, describes the current and potential distribution in an electrochemical cell taking into account the individual transport of charged species (ions) and uncharged species in the electrolyte due to diffusion, migration, and convection using the Nernst–Planck equations. The physics interface supports different descriptions of the coupled charge and mass transport in the electrolyte (see [Electrolyte Charge Conservation](#) below). The electrode kinetics for the charge transfer reactions can be described by using arbitrary expressions or by using the predefined Butler–Volmer and Tafel expressions.

Ohm’s law is used in combination with a charge balance to describe the flow of currents in the electrodes. The charge transfer reactions can be defined as boundary

conditions or as sources or sinks within a domain in order for the case of porous electrodes.



### SETTINGS

The **Label** is the physics interface node name that will be shown in the model builder tree.

The **Name** is used primarily as a scope prefix for variables defined by the physics interface. Refer to such physics interface variables in expressions using the pattern `<name>.<variable_name>`. In order to distinguish between variables belonging to different physics interfaces, the `name` string must be unique. Only letters, numbers, and underscores (`_`) are permitted in the **Name** field. The first character must be a letter.

The default **Name** (for the first physics interface in the model) is `tc.d`.

### DOMAIN SELECTION

The domains that do not conduct current should be omitted from the selection list, for example, the gas channels in a fuel cell.

### OUT-OF-PLANE THICKNESS

For 2D components, the **Thickness** field (default value: 1 m) defines a parameter for the thickness of the geometry perpendicular to the two-dimensional cross-section. The value of this parameter is used, among other things, to automatically calculate the total current from the current density vector. The analogy is valid for other fluxes.

### CROSS-SECTIONAL AREA

For 1D components, enter a **Cross-sectional area**  $A_c$  (SI unit:  $\text{m}^2$ ) to define a parameter for the area of the geometry perpendicular to the 1D component. The value of this parameter is used, among other things, to automatically calculate the total current from the current density vector. The analogy is valid for other fluxes. The default is  $1 \text{ m}^2$ .

### ELECTROLYTE CHARGE CONSERVATION

The physics interface features five different descriptions of the coupled charge and mass transport in the electrolyte.

Use the **Electroneutrality** or the **Water-based with electroneutrality** charge conservation option to model cells with significant concentration gradients of the current-carrying species (ions). The electroneutrality condition implicitly assumes that all major current-carrying ions are included in the model. In addition to the electroneutrality condition, the **Water-based with electroneutrality** option also adds the water auto-ionization equilibrium condition, including proton and hydroxide transport, when defining the electrolyte equations. Note that this option adds the concentration variables for protons (tcd.cH) and hydroxide (tcd.OH) automatically, and that dependent variables for these two species should not be added under **Dependent Variables** underneath. With this setting, to control the initial pH in a simulation, set the initial concentrations of the other ions in the simulation such that the matching concentrations of protons and hydroxide ions match the pH desired. For pH below 7, add and set the concentration of anions. For pH above 7, add and set the concentration of cations. For example, for a water-based system with only Cl<sup>-</sup>, an initial concentration for Cl<sup>-</sup> of 10<sup>-5</sup> M will result in an initial pH of 5. This is analogous to acidifying the solution using HCl.

A **Supporting electrolyte** describes a situation where the major part of the charge is transferred by ions whose concentration can be described as constant.

Use the **Electroanalysis** (no potential gradients) option to model electroanalytical problems with electrolyte solutions containing a large quantity of inert supporting electrolyte, with a conductivity so high that ohmic losses can be assumed to be negligible. The electroanalysis option will not solve for the electrolyte potential as a dependent variable, setting it to a constant value of 0. Migration effects are hence neglected. Domain and boundary nodes only applicable to the electrolyte phase potential will be disabled when using electroanalysis.

The **Poisson** option couples the Nernst–Planck equations for mass transport to the Poisson equation for describing the potential distribution in the electrolyte, without any assumption of electroneutrality. This option is typically used when modeling problems where charge separation effects are of interest, typically within nanometers from an electrode surface.

For the Electroneutrality option, the **From electroneutrality** list sets the species that is calculated from the corresponding condition. Note that the choice of species to be taken from electroneutrality affects the specific boundary conditions that can be set on the eliminated species. For example, flux and concentration settings cannot be set for the eliminated species, and initial values cannot be provided. The choice can also have an impact on the numerics of the problem.

A general advice is to choose a relatively inert ion with high mole fraction to be taken from electroneutrality for best numerical results.

### PHYSICS VS. MATERIALS REFERENCE ELECTRODE POTENTIAL

The **Physics vs. Materials Reference Electrode Potential** setting on the physics interface node can be used to combine material library data for current densities and equilibrium potentials with an arbitrary reference electrode scale in the physics. The setting affects the electrode potentials used for model input into the materials node, as well as all equilibrium potential values output from the materials node.

Note that the setting will only impact how potentials are interpreted in communication between the physics and the **Materials** node. If the **From material** option is not in use for equilibrium potentials or electrode kinetics, the setting has no impact.

### ADVANCED SETTINGS

To display this section, click the **Show** button (  ) and select **Advanced Physics Options**. Normally these settings do not need to be changed. Select a **Material Balance Form** — **Nonconservative** (the default) or **Conservative**. The selection affects the formulation of the convective term and, for porous domain nodes, also the accumulation term in the material balance. For compressible electrolytes the conservative form should be used. In the absence of convection and electrolyte volume fraction changes (porosity), the choice between the conservative and nonconservative form is arbitrary. The nonconservative form is usually preferred due to a slighter lower computational load.

### DEPENDENT VARIABLES

This physics interface defines these dependent variables (fields), the **Concentrations** of the species, the **Electrolyte potential**, and the **Electric potential**.

The names can be changed but the names of fields and dependent variables must be unique within a model.

### DISCRETIZATION

**Concentrations** basis function orders higher than **Quadratic** are not recommended if transport by convection is dominating in the model.

To see all settings in this section, click the **Show More Options** button (  ) and select **Advanced Physics Options** from the **Show More Options** dialog.

## CONSISTENT STABILIZATION AND INCONSISTENT STABILIZATION

To display these sections, click the **Show More Options** button (  ) and select **Stabilization** from the **Show More Options** dialog. There are two consistent stabilization methods available and selected by default — **Streamline diffusion** and **Crosswind diffusion**. There is one inconsistent stabilization method, **Isotropic diffusion**, which is not selected by default. Any settings unique to this physics interface are listed below.

- When the **Crosswind diffusion** checkbox is selected, a weak term that reduces spurious oscillations is added to the transport equation. The resulting system is nonlinear. There are two options for **Crosswind diffusion type**:
  - **Do Carmo and Galeão** — the default option. This type of crosswind diffusion reduces undershoot and overshoot to a minimum but can in rare cases give equations systems that are difficult to fully converge.
  - **Codina**. This option is less diffusive compared to the Do Carmo and Galeão option but can result in more undershoot and overshoot. It is also less effective for anisotropic meshes. The Codina option activates a text field for the **Lower gradient limit**  $g_{\text{lim}}$  (SI unit: mol/m<sup>4</sup>). It defaults to  $0.1 [\text{mol}/\text{m}^3] / \text{tds}.\text{helem}$ , where  $\text{tds}.\text{helem}$  is the local element size.
- For both consistent stabilization methods, select an **Equation residual**. **Approximate residual** is the default setting and it means that derivatives of the diffusion tensor components are neglected. This setting is usually accurate enough and is faster to compute. If required, select **Full residual** instead.



In the *COMSOL Multiphysics Reference Manual* see [Table 2-4](#) for links to common sections and [Table 2-5](#) to common feature nodes. You can also search for information: press F1 to open the **Help** window or Ctrl+F1 to open the **Documentation** window.



- [The Nernst–Planck Equations](#)
- [Domain Equations for Tertiary Current Distributions Using the Nernst–Planck Equations and Electroneutrality](#)
- [Shared Physics Features in the Current Distribution Interfaces](#)
- [Theory for the Current Distribution Interfaces](#)

## Electrolyte

---

Use the **Electrolyte** node to define an electrolyte domain that only conducts current in the ion conducting phase. The combined charge and mass transfer in the electrolyte is defined by the node.

What settings are available in this node depends on the [Electrolyte Charge Conservation](#) setting, available on the top node. The **Electrolyte conductivity** (SI unit: S/m) setting is only available for the **Supporting Electrolyte** option. Diffusivity and mobility settings for  $H^+$  and  $OH^-$  are only available for the **Electroneutrality, water-based** option.

The **Convection** section is available when the **Convection** checkbox is selected on the interface top node. The **Velocity field  $\mathbf{u}$**  (SI unit: m/s) of the solvent is specified as a feature input. Select the source of velocity field from the velocity field list.

By default the **Mobility** (SI unit: s·mol/kg) for each species is set to be calculated based on the diffusion coefficients (SI unit:  $m^2/s$ ) specified in the **Diffusion** section and the temperature using the **Nernst–Einstein relation**.

The mobility setting will only have an impact on the transport by migration of charged species, as defined by the **Charge number  $z_c$**  (dimensionless, specify negative charges using a minus sign). For the **Electroneutrality** charge conservation model you need at least one positively and one negatively charged species (ion) in the electrolyte.

Specify the temperature (if you are using mobilities based on the **Nernst–Einstein relation**) in the **Model Inputs** section.

The **Water Self-ionization** section is available for the **Water-based with electroneutrality** option. The section allows the water self-ionization constant to be set. Using the **Built in** option, the constant will be set to account for temperature, giving the pH of the simulation the correct temperature dependence.

Note that the electrolyte in this case does not refer to the pore electrolyte in porous electrodes (which should be defined by a [Porous Electrode](#) node instead). For porous separators, use the [Separator](#) instead.



- [Electrolyte Theory](#)
  - [Domain Equations for Tertiary Current Distributions Using the Nernst–Planck Equations and Electroneutrality](#)
-

## *Porous Electrode*

---

The **Porous Electrode** node sets up charge balances for the electrode and the pore electrolyte in a porous electrode, and as well as the mass balance for the species in the electrolyte.

Note that the node should be used for porous domains that conduct current in both an electrolyte and an electrode phase. For the case of domains that do not contain a pore electrolyte — for instance, the gas diffusion layer (GDL) in a PEMFC electrode — use an Electrode node instead.

Use Porous Electrode Reaction child nodes to define the charge transfer reactions that occur on the interface between the electrolyte and electrode phases within the porous electrode. The Porous Matrix Double Layer Capacitance subnode is also available.

See the [Electrolyte](#) node for more information about the **Diffusion** and **Migration in Electric Field** settings of this node.

Correction factors may be specified in the **Effective Transport Parameter Correction** section to account for the lowered effective conductivities of the electrode and electrolyte phases due to the lower volume fractions of each phase, and the tortuosity of the porous matrix.

The **Electrode volume fraction** is used to calculate the effective electric conductivity of the porous matrix when the correction factor is set to **Bruggeman** or **Tortuosity**. Additionally, it is used in calculating the active specific surface area of the porous matrix when **Particle-based area** option is selected in the child nodes.

### **ADSORBING–DESORBING SPECIES**

See the [Electrode Surface](#) node.

### **FILM RESISTANCE**

See the [Electrode Surface](#) node.



- [Porous Electrode Theory](#)
  - [Porous Electrode Reactions Theory](#)
  - [Domain Equations for Tertiary Current Distributions Using the Nernst–Planck Equations and Electroneutrality](#)
-

## *Separator*

---

Use a **Separator** node to model electrolyte charge and mass transport in an electronically isolating porous matrix. Use correction factors to account for the lowered diffusion coefficients in the electrolyte and the lowered conductivities of the electrode, due to the lower volume fractions of each phase and the tortuosity of the porous matrix.

See also the [Electrolyte](#) node for more information about the **Diffusion** and **Migration in Electric Field** settings of this node.

## *Reactions*

---

Use the **Reactions** node to define nonelectrochemical reactions in an electrolyte domain.

The node is found from the **Additional Sources** submenu.

### **REACTING VOLUME**

When specifying reaction rates in the  $R_{e2}$  (SI unit: mol/m<sup>3</sup>·s) fields for a species in a [Porous Electrode](#) domain, the specified reaction rate expression may either refer to the total volume or the pore (electrolyte) volume. For nonporous domains the settings of the Reacting Volume section has no impact.

For **Total volume** the reaction expressions are used as specified (multiplied by unity).

For **Pore volume** this results in the specified reaction expressions being multiplied by the domain electrolyte volume fraction  $\epsilon_l$ . ( $\epsilon_l$  equals unity for nonporous domains).

## *Initial Values*

---

Use this node to specify the **Initial Values** of the concentration, electrolyte potential and electric potential dependent variables to be used by the solver.

For many electrochemical problems that use nonlinear electrode kinetics, such as Butler–Volmer kinetics, providing reasonable initial values can significantly improve solver convergence.

A good value for the **Electric potential** (SI unit: V) in electrode and porous electrode domains can usually be derived from the boundary conditions. For instance, if a boundary has been grounded or set to a cell potential, use that value as the initial value

also in the adjacent domain. For the **Electrolyte potential** (SI unit: V) a good initial value is often the negative of the equilibrium potential of the grounded electrode.

For the **Concentration** initial values, at least one positive and one negative charged species should have a nonzero and positive initial value (after considering the electroneutrality condition). The initial value for the ion calculated from the electroneutrality condition cannot be set explicitly.

### *Ion-Exchange Membrane*

---

Use the **Ion-Exchange Membrane** node to specify a domain with a permanent fixed space charge. The node is typically used for defining permselective membranes, used for various applications such as dialysis cells or flow batteries.

The node models the transport of all species added at the interface top node, and adds a fixed space charge to the electroneutrality condition.

The **Fixed space charge** specifies the charge ions fixed in the membrane polymer matrix. Use negative space charges for cation selective membranes and positive charges for anion selective membranes, respectively.

Select the **Apply Donnan Boundary Conditions** checkbox to enable Donnan equilibrium conditions on all interior boundaries between the domain selected by the node and all adjacent domains selected by the interface (except **Electrode** nodes). The boundary conditions are applied for all species and the electrolyte potential dependent variable. This option is not available for the **Poisson** charge conservation model option.

The **Add Donnan shift to initial values** checkbox, when enabled, shifts the initial values (concentration and potential values specified on the Initial Values node) for the active selection of the ion-exchange membrane node in order to fulfill electroneutrality and compliance with the Donnan equilibria. It is assumed that the user-defined initial values represent the values for a bulk liquid electrolyte in equilibrium with the membrane. The shifted initial values are then used as initial values to the solver. This option facilitates model setup, since it typically excludes the need to sweep the fixed space charge of the membrane to a desired nonzero value using an additional study step. This option is only available for the **Electroneutrality** or the **Water-based with electroneutrality** charge-conservation model options.

For the remaining settings of this node, see the [Electrolyte](#) and [Separator](#) nodes.

## *Ion-Exchange Membrane Boundary*

---

Use the **Ion-Exchange Membrane Boundary** node to specify an exterior boundary over which the flux of a charge-carrying species is continuous but the electrolyte potential shifts with a specified value. This condition is typically used in electrochemical cells containing both free electrolytes and ion-exchange membranes, for instance in dialysis or flow-battery problems. The node is typically used to couple two separate current distribution interfaces, where one of the interfaces models a free-electrolyte domain and the other models the ion-exchange membrane domain.

Note that using the **Ion-Exchange Membrane** domain node often is a more convenient modeling approach if the transported species in the free electrolyte and ion-exchange membrane are the same.

The node is applicable to exterior boundaries to electrolyte domains. For defining ion-exchange membranes on an interior boundary between two electrolyte domains, use the **Thin Electrolyte Layer** node.

The choice of **Charge-carrying species concentration species** specifies that the current flowing over the boundary will be carried by this species (which must have a nonzero charge number). Use the **Membrane potential** setting to set the electrolyte potential on the membrane side of the boundary. Note that if this potential is set to the electrolyte potential of a Primary Current Distribution or a Secondary Current Distribution interface, no additional settings are needed in that interface to set up the correct boundary condition.

The potential condition may be either **Donnan**, which will calculate the potential shift over the boundary based on the membrane charge carrying species concentration, or can be **User defined**.

## *Thin Electrolyte Layer*

---

Use this node to specify a thin layer on an interior boundary between two electrolyte domains. The node can be used as an alternative to drawing the actual layer as a domain in the model geometry, which may significantly reduce meshing and solver time, especially in 3D models.

The layer may either be **Insulating, Resistive** (supporting electrolytes only), or an **ion-exchange membrane**.

For **Resistive** or **ion-exchange membrane**, the potential drop over the membrane is determined either from the **Surface resistivity** or the **Thickness and conductivity**.

For **ion-exchange membrane**, the choice of **Charge-carrying species concentration species** specifies that the current flowing over the layer will be carried by this species (which must have a nonzero charge number). The potential condition may be either **Donnan**, which calculates the potential shift over the boundary based on the membrane charge carrying species concentration, or **User defined**.

# Shared Physics Features in the Current Distribution Interfaces

## *Domain, Boundary, Pair, Edge, and Point Nodes for the Electrochemistry Interfaces*

---

This chapter describes various domain, boundary, edge, point, and pair nodes that are common to several of the [Electrochemistry Interfaces](#) interfaces.

The nodes are available from the **Physics** ribbon toolbar (Windows users), **Physics** context menu (macOS or Linux users), or right-click to access the context menu (all users). The nodes and features described in this section are available for all the Electrochemistry branch interfaces unless otherwise indicated.



In general, to add a node, go to the **Physics** toolbar, no matter what operating system you are using. Subnodes are available by (right-)clicking the parent node and selecting it from the **Attributes** menu.

---

- Circuit Terminal
- Current Conductor
- Double-Layer Capacitance
- Electric Ground
- Electric Potential
- Electric Reference Potential
- Current Conductor
- Electrode Current
- Electrode Current Density
- Electrode Current Source
- Electrode–Electrolyte Boundary Interface
- Electrode Potential
- Electrode Power
- Electrode Reaction
- Electrode Surface
- Electrolyte Current
- Electrolyte Current Density
- Electrolyte Current Source
- Electrolyte Potential
- External Short
- Harmonic Perturbation
- Highly Conductive Porous Electrode
- Initial Values for Adsorbing–Desorbing Species
- Insulation
- Internal Electrode Surface
- Perforated Electrode Surface
- Perforated Electrode Surface
- Internal Electrode Surface
- Line Mass Source<sup>1</sup>
- Load Cycle
- Perforated Electrode Surface
- Point Mass Source<sup>1</sup>
- Porous Electrode Reaction
- Porous Matrix Double-Layer Capacitance
- Reference Electrode
- Symmetry
- Thin Electrode Layer
- Thin Electrode Surface

<sup>1</sup> For the Tertiary Current Distribution, Nernst–Planck interface, these nodes are available and described for the Transport of Diluted Species interface.



In the *COMSOL Multiphysics Reference Manual* see [Table 2-4](#) for links to common sections and [Table 2-5](#) to common feature nodes. You can also search for information: press F1 to open the **Help** window or Ctrl+F1 to open the **Documentation** window.



### *Current Conductor*

---

Use the **Current Conductor** node to define an electrode domain that only conducts current in the electron conducting phase.

The node is typically used for modeling solid metal electrodes, current collectors, current feeders, gas diffusion layers and gas backings.

The **Electric conductivity**  $\sigma_s$  (SI unit: S/m) parameter will define how the current in the domain depends on the gradient of the potential.



### *Highly Conductive Porous Electrode*

---

The **Highly Conductive Porous Electrode** node defines a charge balance of the pore electrolyte in a porous electrode, and, for interfaces solving for electrolyte species, the corresponding mass balance for the species in the electrolyte. Use this node when electric conductivity is high enough to assume uniform potential in the electron conducting phase of the porous electrode.

See the [Electrode Surface](#) node for a description of the Electrode Phase Potential Condition and Harmonic Perturbation sections.

See the [Porous Electrode](#) node for a description of the remaining settings.

### *Electrode Current Source*

---

Use the **Electrode Current Source** node to define contributions to the current density from electron current sources. The **Current source**,  $Q_s$  (SI unit: A/m<sup>3</sup>), is added according to the following equation:

$$\nabla \cdot \mathbf{i}_s = Q_s$$

where

$$\mathbf{i}_s = -\sigma_s \nabla \phi_s$$

and  $\sigma_s$  denotes the electrode's conductivity and  $\phi_s$  the electric potential.

To use this feature, click the **Show More Options** button (  ) and select **Advanced Physics Options** in the **Show More Options** dialog. Then add the node from the **Additional Sources** submenu.

### *Electrolyte Current Source*

---

Use the **Electrolyte Current Source** node to define contributions to the current density in the electrolyte from, for example reactions, or other effects.

The **Current source**,  $Q_1$  (SI unit: A/m<sup>3</sup>), is added according to the following equation:

$$\nabla \cdot \mathbf{i}_l = Q_l$$

To use this feature, click the **Show More Options** button (  ) and select **Advanced Physics Options** in the **Show More Options** dialog. Then add the node from the **Additional Sources** submenu.

### *Porous Electrode Reaction*

---

The **Porous Electrode Reaction** node defines the electrode kinetics for a charge transfer reaction that occurs at the interface between the pore electrolyte and the electrode matrix a porous electrode. The node can be added as subnode to a **Porous Electrode** node. Add multiple nodes to the same **Porous Electrode** node to model multiple reactions, for instance in mixed potential problems.

See the [Electrode Reaction](#) node for a description of the Equilibrium Potential, Electrode Kinetics, Stoichiometric Coefficients and Heat of Reaction sections.

#### **ACTIVE SPECIFIC SURFACE AREA**

The **Active specific surface area**,  $a_v$  (SI unit: m<sup>2</sup>/m<sup>3</sup>) specifies the area of the electrode-electrolyte interface that is catalytically active for this porous electrode reaction.  $a_v$  is multiplied by  $i_{loc}$ , defined in the Electrode Kinetics section, to produce a current source in the domain.

This section is not available for primary current distribution interfaces.



- [Porous Electrode Reactions Theory](#)
- [Electrode Kinetics Expressions.](#)

### *Porous Matrix Double-Layer Capacitance*

Use the **Porous Matrix Double-Layer Capacitance** subnode to define a nonfaradaic double-layer current density at the interface between the porous electrode matrix and the electrolyte. The resulting double-layer current source in the **Porous Electrode** domain depends on the time derivative of the potentials and is proportional to both the **Electrical double-layer capacitance**  $C_{dl}$  (SI unit:  $F/m^2$ ) and the **Double-layer area**  $\alpha_{v,dl}$  (SI unit:  $1/m$ ). The node can be added as subnode to a **Porous Electrode** node.

Use this node to simulate transient analysis techniques such as AC-impedance analysis and current interrupt studies. Note that for stationary problems the double-layer current is zero.

This node is not available for the Primary Current Distribution interface.

### **STOICHIOMETRIC COEFFICIENTS**

Use the settings of the **Stoichiometric Coefficients** section (not available in the Primary or Secondary Current Distribution interfaces) to control what species are participating in the double-layer charging — that is, the mass exchange between the double layer and the electrolyte outside the double layer.

The number of participating electrons should be chosen so that the mass exchange is scaled correctly to the double layer charging current.

The stoichiometric coefficients,  $\nu_i$ , should be chosen considering the situation when the porous electrode is being cathodically polarized. In other words, use a negative stoichiometric coefficient for ions (species  $S_i$ ) that are transported into the double layer of the electrode that is being cathodically polarized (typically the cations), and positive stoichiometric coefficients for ions (species  $S_i$ ) that are transported out of the double layer (typically the anions).

## *Insulation*

---

The **Insulation** boundary condition describes the walls of a cell or the boundaries of the cell that do not face a conductor. The boundary condition imposes the following equation:

$$\mathbf{i}_k \cdot \mathbf{n} = 0$$

where  $\mathbf{i}_k$  denotes the current density vector and  $k = l, s$  is an index for the electrolyte and electrode, respectively.

## *Symmetry*

---

For the Primary Current Distribution and Secondary Current Distribution interfaces, the **Symmetry** boundary condition is identical to the [Insulation](#) condition.

For the Tertiary Current Distribution, Nernst–Planck interface, the **Symmetry** boundary condition imposes a no flux condition for the molar flux of species at a boundary.



Symmetry Theory

---

## *Electrode Surface*

---

Use the **Electrode Surface** node to model an electrochemical electrode-electrolyte interface between an electrolyte domain and an electrode boundary where the electrode is not included explicitly as a domain in the model geometry. Set the electric potential of the electrode or specify a current condition that the potential of the electrode shall fulfill, and use subnodes to specify the [Electrode Reaction](#) and the [Double-Layer Capacitance](#) at the interface.

This node can only be applied on outer boundaries to electrolyte domains. For interior boundaries between electrolyte and electrode domains, use the [Internal Electrode Surface](#) node. For interior boundaries to electrolyte domains, use the [Perforated Electrode Surface](#) node.

### **ADSORBING–DESORBING SPECIES**

Use the settings of this section to define species that can adsorb or desorb on the electrode surface during charge-transfer, or nonfaradaic, reactions.

The **Density of sites parameter** will be used to set up the local surface mass balance equations for the fractional surface coverages.

Use the **Add** ( + ) and **Delete** ( ≡ ) buttons as needed in the table to control the number of species. The name of each adsorbing–desorbing **Species** can be edited in the first column of the table. Use a **Site occupancy number** larger than unity for species that occupy more than one site at the electrode surface.

According to the settings of the table, the fractional surface coverage variable names will be defined according to `xxx.theta_yyy_zzz`, where `xxx` is the interface name, `yyy` the tag of the electrode surface node, and `zzz` the species name. The variable `xxx.thetafree_yyy` represents the fraction of free surface sites. These variable names can be used when defining kinetics parameters in [Electrode Reaction](#) subnodes.



Use [The Surface Reactions Interface](#) to model surface diffusion.

---

#### FILM RESISTANCE

Use a film resistance if you want to include an additional potential drop due to an ohmic resistance at the interface between the electrode and the electrolyte, for instance due to buildup of insulating deposits.

Specify either a **Surface resistance**  $R_{\text{film}}$  (SI unit:  $\Omega \cdot \text{m}^2$ ) directly or choose the **Thickness and conductivity** option to calculate the surface resistivity based on a depositing film thickness.

#### HARMONIC PERTURBATION

Use this section in conjunction with AC Impedance study types to control the perturbation amplitude in the frequency domain.

The perturbation parameter is either **Electric potential**, **Electrode potential**, **Total current**, or **Average current density**, based on the **Boundary condition** selected in the next section.

The frequency spectrum is specified in the study node.

#### ELECTRODE PHASE POTENTIAL CONDITION

This section specifies the potential in the electrode phase of the electrolyte-electrode interface. The electrode potential is used (via the overpotential) by the **Electrode Reaction** subnodes.

Use the **Electric potential** option to set the value of the potential explicitly with respect to ground whereas the **Electrode potential** will set the potential value with respect to a reference potential. **Total current**, **Average current density**, **External short** and **Load Cycle** all add an extra global degree of freedom for the potential in the electrode phase, set to comply with the chosen condition. When using the **Total current** option in 1D or 2D, the boundary area is based either on the **Cross-sectional area** (1D), or the **Out-of-Plane thickness** (2D) properties, set on the physics interface top node.

In the Lithium-Ion Battery and the Battery with Binary Electrolyte interfaces, if the **Define cell state of charge (SOC) and initial charge inventory** checkbox has been ticked in the Cell Settings section on the physics interface top node, the **Total current** can be specified either explicitly or as a multiple of the C-rate current variable (`xxx.I_1C_cell`, where xxx is the physics interface tag) that is defined by the global [SOC and Initial Charge Distribution](#) node.

The **Load Cycle** setting activates a [Load Cycle](#) child node where the settings for this option are located.

See also the documentation for the [Electrode Potential](#) and [External Short](#) nodes for further information about these boundary conditions.

### Cyclic Voltammetry

The **Cyclic voltammetry** setting varies the electric potential linearly in time as follows when used in conjunction with a Cyclic Voltammetry study step:

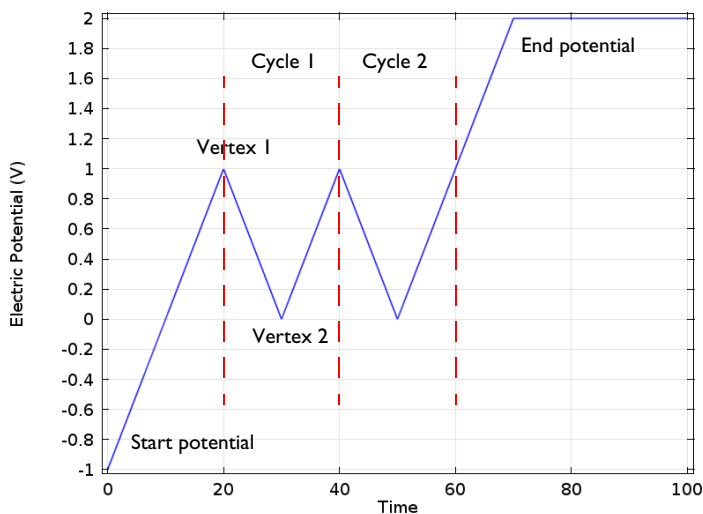

Figure 3-1: Electric potential vs time generated by the cyclic voltammogram boundary condition. The linear sweep rate is 100 mV/s, the number of cycles is 2. Potentials levels are also shown.

More advanced waveforms can be obtained using the **Electric potential** option with a parameter setting based on **Functions** found in the **Definitions** menu.

### Counter Electrode (Electroanalysis Only)

This boundary condition is only available for the **Electroanalysis** charge conservation model in the **Tertiary Current Distribution, Nernst–Planck (tcd)** interface.

The **Counter electrode** option sets a potential to ensure an overall charge balance of the cell so that the integral of all electrode reaction currents of all electrode surface node evaluates to zero.

See also [Counter Electrodes and Overall Charge Balance](#).

### ADVANCED CYCLIC VOLTAMMETRY SETTINGS

To display this section, click the **Show More Options** button (  ) and select **Advanced Physics Options** in the **Show More Options** dialog.

If **Cyclic voltammetry** is selected as the **Boundary condition**, the checkboxes **Add events at vertex potentials in cyclic voltammetry** and **Smoothing of cyclic voltammetry wave functions** are both selected by default.

When **Smoothing of cyclic voltammetry wave functions** is enabled, smoothing is applied on the triangular wave around the vertex potentials. The **Smoothing factor** defaults to  $1 \cdot 10^{-3}$ . The smoothing zone corresponds to the product of the smoothing factor with half the duration of one period of the triangular wave.

When **Add events at vertex potentials in cyclic voltammetry** is enabled, solver events are added at the vertex potentials for the cyclic voltammogram. When the vertex potentials are reached, these events cause the solver to stop, reinitialize some variables, and then continue. This typically improves solver convergence. In addition, by forcing the time-dependent solver to resolve the time steps when the vertex potentials are reached, the solution accuracy is improved, especially if the solver is set to output solutions before and after events.

#### **EQUILIBRIUM POTENTIAL HANDLING (PRIMARY CONDITION)**

This setting only has an effect if there are multiple Electrode Reaction subnodes present and if either a Current Distribution Initialization study step (using a Primary Current distribution type) or the Primary Current Distribution interface is used.

The setting determines which equilibrium potential value will be used for defining the primary current distribution constraint. When the **First reaction** has been selected, the first electrode reaction subnode must be active in the model.

To display this section, click the **Show More Options** button (  ) and select **Advanced Physics Options** in the **Show More Options** dialog.

#### **CONSTRAINT SETTINGS**

For primary current distributions, the use of weak constraints will in some cases give a more accurate value of the local current density during the solver process. This may in turn render more accurate results when coupling to the local current density variable to describe other phenomena in the model, for instance when modeling geometry deformation due to electrode dissolution/deposition.

The section is available in the Primary Current Distribution and Secondary Current Distribution interfaces when the **Current Distribution Model** property has been set to **Primary**.

This section is only available in the Primary Current Distribution and Secondary Current Distribution interfaces when the **Current Distribution Model** property has been

set to **Primary**. To display this section, click the **Show More Options** button (  ) and select **Advanced Physics Options** in the **Show More Options** dialog.



- [Electrode Reactions Theory](#)
- [Film Resistance](#)

### *Electrode Reaction*

The **Electrode Reaction** subnode defines the electrode kinetics for a charge transfer reaction that occurs on an electrolyte-electrode interface boundary. Use multiple nodes to model multiple reactions, for instance in mixed potential problems.

The parent node can be either an [Internal Electrode Surface](#) or an [Electrode Surface](#).

Note that all settings described below are not available for all Electrochemistry interfaces.



- [Electrode Reactions Theory](#)

### **EQUILIBRIUM POTENTIAL**

The **Equilibrium potential**,  $E_{\text{eq}}$  (SI unit: V), is used in the electrode kinetics expressions in the Electrode Kinetics section (via the definition of the overpotential), or for setting up primary current distribution potential constraints.

The equilibrium potential can be defined either in the Materials node (**From material**), by using the **Nernst Equation**, or by using a **User defined** expression.

If the Nernst Equation is used, the concentration dependence is calculated automatically based on the **Reference equilibrium potential**  $E_{\text{eq, ref}}$  (V).

For all interfaces except the Tertiary Current Distribution interface, the concentration dependence is based on the user-defined **Reduced species expression**  $C_R$  (unitless) and **Oxidized species expression**  $C_O$  (unitless) parameters.  $C_R$  and  $C_O$  should be defined so that the quotient between them is 1 for the reference state (for which  $E_{\text{eq}} = E_{\text{eq, ref}}$ ).

In the Tertiary Current Distribution interface, the concentration dependence of the Nernst Equation is based entirely on the settings in the **Stoichiometric Coefficients** and the **Reference Concentrations** sections.

When using Nernst Equation, additional options are available in the **Butler–Volmer** expression type in the Electrode Kinetics section.



- [Equilibrium Potentials and the Nernst Equation](#)

### REFERENCE CONCENTRATIONS

This section is only available in the Tertiary Current Distribution interface, if the equilibrium potential has been selected to be defined by the **Nernst Equation**.

The reference concentrations define the reference state for which  $E_{\text{eq}} = E_{\text{eq,ref}}$ .

### ELECTRODE KINETICS

The settings of this section will define the local current density,  $i_{\text{loc}}$  (SI unit:  $\text{A}/\text{m}^2$ ), at the interface between the electrolyte and the electrode. Note that  $i_{\text{loc}}$  for all built-in kinetics expression types will depend on the overpotential, which in turn depend on the Equilibrium potential defined in the previous section.

The **Local current density expression**,  $i_{\text{loc,expr}}$  (SI unit:  $\text{A}/\text{m}^2$ ), can be defined either in the Materials node (**From material**), by using the **From kinetics expression**, or by using a **User defined** expression.

For all kinetic expressions the **Exchange current density**  $i_0$  (SI unit:  $\text{A}/\text{m}^2$ ) is a measure of the kinetic activity. The exchange current density is typically concentration dependent.

Most kinetic expression types feature the **Limiting Current Density** option in order to impose an upper limit on the local current density magnitude. The feature can be used to model additional mass transport limitations that are not already included in the local current density expression. For **Limiting Current Density** enter a value for  $i_{\text{lim}}$  (SI unit:  $\text{A}/\text{m}^2$ ).

In the Tertiary Current Distribution interface, the **Linearize concentration dependence for low concentrations** option is used to set a **Concentration linearization limit**  $c_{\text{lim}}$  (SI unit:  $\text{mol}/\text{m}^3$ ) for linearizing the concentration dependence of kinetics for low concentrations, in order to improve convergence for nonunit stoichiometries. Note that this option is available for **Nernst Equation** equilibrium potential and **Butler–Volmer** kinetics with either **Mass action law** or **Lumped multistep** selected as the exchange current density type.

### *Butler–Volmer or Linearized Butler–Volmer*

The Butler–Volmer kinetics expression is the most common way to define electrochemical kinetics. The **Linearized Butler–Volmer** is valid when the overpotentials of the reactions are small ( $\ll 25$  mV). The linearized version can also be used to troubleshoot a model with convergence problems.

When using the **Nernst Equation** for defining the equilibrium potential (see above), the concentration dependence of the **Exchange current density**  $i_0$  can be defined in a thermodynamically consistent way in accordance with the Nernst equation, in combination with a **Reference exchange current density**  $i_{0,\text{ref}}$  ( $\text{A}/\text{m}^2$ ), which is the exchange current density when  $E_{\text{eq}} = E_{\text{eq,ref}}$ .

For all interfaces except the Tertiary Current Distribution interface, the concentration dependence when using **From Nernst Equation** will use  $C_R$  and  $C_O$  as preexponential factors for the anodic and cathodic terms, respectively. In the Tertiary Current Distribution interface, the **Lumped multistep** option can be used to define  $i_0$  by the use of either **Generic** exponentials, or **Anodic** or **Cathodic** reaction orders. The **Mass action law** will define the reaction orders according to the reaction stoichiometry and the law of mass action.

The **Anodic transfer coefficient**,  $\alpha_a$  (dimensionless), and **Cathodic transfer coefficient**,  $\alpha_c$  (dimensionless), parameters will impact how much  $i_{\text{loc}}$  will change upon changes in the overpotential. In order to ensure thermodynamic consistency,  $\alpha_c$  cannot be user defined when  $i_0$  is calculated **From Nernst Equation** (or by **Mass action law** in the Tertiary Current Distribution interface). For this case,  $\alpha_c$  is defined automatically, based on the number of participating electrons in the reaction, defined in the stoichiometry section.

### *Anodic Tafel Equation*

This kinetics expression type neglects the cathodic (negative) term in the Butler–Volmer equation. It is only valid for electrode reactions with high anodic overpotentials ( $\gg 100$  mV).

The **Anodic Tafel slope**,  $A_a$  (SI unit: V), defines the required increase in overpotential to result in a tenfold increase in the current density.

### *Cathodic Tafel Equation*

This kinetics expression type neglects the anodic (positive) term in the Butler–Volmer equation. It is only valid for electrode reactions with significant cathodic overpotentials ( $\ll -100$  mV).

The **Cathodic Tafel slope**,  $A_c$  (SI unit: V), describes the required decrease in overpotential to result in a tenfold increase in the current density magnitude.  $A_c$  should be a negative value.

#### *Concentration Dependent Kinetics*

This expression type is not available if **Nernst equation** has been selected in the Equilibrium Potential section.

Note that the combination of **Nernst equation** and the **Butler–Volmer** kinetics type will in most cases render identical kinetics as for the Concentration Dependent Kinetics. It is recommended to always use Nernst Equation + Butler–Volmer whenever possible, since this combination is guaranteed to be thermodynamically consistent.

The Concentration Dependent Kinetics expression type can be used in concentration dependent (tertiary) current distribution problems. One or both of the **Oxidizing species expression**  $C_O$  (dimensionless) and **Reducing species expression**  $C_R$  (dimensionless) parameters can be concentration dependent, and should typically be defined so that  $C_O = C_R$  at equilibrium.



- [Electrode Kinetics Expressions](#)

---

#### *Fast Irreversible Electrode Reaction*

This kinetics expression type is typically used in tertiary current distribution problems for reactions occurring far away from the equilibrium potential.

The kinetics expression type defines an irreversible electrode reaction where the kinetics is so fast that the only factor limiting the reaction rate is the transport of a species to the reacting surface.

The node will set the **Rate limiting species concentration to zero** at the boundary, and balance the fluxes of the species participating in the reaction and the current densities according to the Stoichiometric Coefficients settings.

#### *Thermodynamic Equilibrium (Primary Condition)*

This choice imposes a zero overpotential for the electrode reaction by applying a constraint on the potential variables in order to comply with the equilibrium potential. Use this kinetics for very fast reactions.

In the Secondary Current Distribution interface the condition set by this expression type is mathematically identical to what is applied when a Primary Current

Distribution is chosen on the interface top node. The expression type can hence be used to mix primary and secondary current distributions on different electrodes. The Thermodynamic equilibrium (primary condition) cannot not be used when defining the kinetics for multiple electrode reactions at the same electrode in the Secondary Current Distribution interface.

### STOICHIOMETRIC COEFFICIENTS

Specify the **Number of participating electrons**  $n_m$  in the electrode reaction and the **Stoichiometric coefficient** ( $v_{c1}$ ,  $v_{c2}$ , and so forth) for each of the involved species according to the following generic electrochemical reaction:

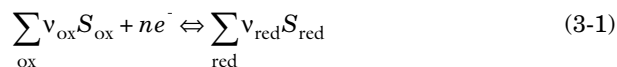

Set  $v_i$  as positive ( $v_{\text{red}}$ ) for the reduced species and negative ( $v_{\text{ox}}$ ) for the oxidized species in an electrochemical reaction. The number of participating electrons,  $n$ , should be positive.

If the concentration of a species in the charge conservation model for the electrolyte is based on an algebraic expression (such as the electroneutrality condition, or the water auto ionization), the stoichiometric coefficient for this species cannot be set explicitly. The stoichiometric coefficient will instead be set implicitly, based on the number of electrons and the stoichiometric coefficients of the other species participating in the reaction.



An easy way to determine the stoichiometric coefficients for a reaction is to write the reaction as a reduction reaction (with the electrons on the left), irrespectively on the expected actual direction of the reaction in the model. The species on the left side then have negative coefficients and the species on the right have positive coefficients.



- [Mass Fluxes and Sources Due to Electrochemical Reactions](#)

### HEAT OF REACTION

The **Heat of Reaction** section provides two options: **Temperature derivative** and **Thermoneutral voltage** to calculate the reversible heat source of the electrode reaction, which in turn can be used for coupling to heat transfer physics.

The **Temperature derivative of equilibrium potential** parameter,  $dE_{\text{eq}}/dT$  (SI unit: V/K), can be specified in case of **Temperature derivative** selection. Note that  $dE_{\text{eq}}/dT$  parameter value has no impact on the equilibrium potential variable.

The **Thermoneutral voltage** parameter,  $E_{\text{therm}}$  (SI unit: V), can be specified in case of **Thermoneutral voltage** selection.



- [Heating Due to Electrochemical Reactions](#)

---

### *Double-Layer Capacitance*

---

The **Double-Layer Capacitance** node describes the nonfaradaic currents due to charge and discharge of the double layer situated at the interface between the electrode and the electrolyte. The resulting double-layer current density on the boundary depends on the time derivative of the potentials and is proportional to the **Electrical double-layer capacitance**  $C_{\text{dl}}$  (SI unit: F/m<sup>2</sup>). The parent node can be either an [Internal Electrode Surface](#) or an [Electrode Surface](#).

Use this node to simulate transient analysis techniques such as AC-impedance analysis and current interrupt studies. Note that for stationary problems the double-layer current is zero.

This node is not available for the Primary Current Distribution interface.

#### **STOICHIOMETRIC COEFFICIENTS**

Use the settings of the **Stoichiometric Coefficients** section (not available in the Primary or Secondary Current Distribution interfaces) to control what species are participating in the double-layer charging — that is, the mass exchange between the double layer and the electrolyte outside the double layer.

The number of participating electrons should be chosen so that the mass exchange is scaled correctly to the double layer charging current.

The stoichiometric coefficients,  $\nu_i$ , should be chosen considering the situation when the porous electrode is being cathodically polarized. In other words, use a negative stoichiometric coefficient for ions (species  $S_j$ ) that are transported into the double layer of the electrode that is being cathodically polarized (typically the cations), and positive stoichiometric coefficients for ions (species  $S_j$ ) that are transported out of the double layer (typically the anions).

### *Perforated Electrode Surface*

---

The **Perforated Electrode Surface** node is applicable to interior boundaries of electrolyte domains. The node can be used to model a thin and highly conductive perforated (mesh) electrode, immersed in an electrolyte.

Apart from the applicable selection, the node is identical to the [Electrode Surface](#) node.

### *Internal Electrode Surface*

---

The **Internal Electrode Surface** node defines the electrochemical electrode-electrolyte interface between an electrode domain and the electrolyte domain. Use this node as a parent node for [Electrode Reactions](#) and the [Double-Layer Capacitance](#) of an electrolyte-electrode interface when you explicitly model the electron conducting electrode as a domain in your model.

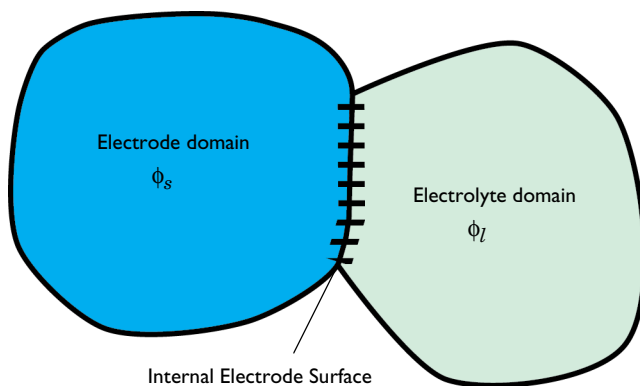

The node can be applied at interior boundaries between electrode and electrolyte domains, and to exterior boundaries of porous electrode domains. Note that, due to the high conductivity of many electrode materials, a [Current Conductor](#) domain can many times be replaced an external condition at the electrolyte boundary. For such cases, consider using the [Electrode Surface](#) instead.

For a description of the Film Resistance and Constraint Settings sections, see the [Electrode Surface](#) node.



- [Electrode Reactions Theory](#)

---

### *Thin Electrode Surface*

---

Use the **Thin Electrode Surface** node to define electrode reactions occurring on a thin electrode, fully immersed in electrolyte. The electrode is assumed to be infinitely thin, and is only applicable to interior boundaries of electrolyte domains.

The node can be used as an alternative to drawing the actual electrode domain in the model geometry, and may significantly reduce meshing and solver time, especially in 3D models. The node can typically be used to model electrodeposition or corrosion processes occurring on thin sheets of metal.

The functionality of the node is similar to the [Electrode Surface](#) node. Use the **Side selection** setting to define if the electrode reactions, defined by the [Electrode Reaction](#) subnodes, are to be defined **Both** sides of the electrode, or on the **Up** or **Down** side only.

Upon application of the node, the electrolyte-potential dependent-variable degree of freedom is defined as a “slit” with different values on each side on the selected boundaries. Additional variables defined by the node depending on the electrolyte potential, also having different values on each side of the interior boundary, are named using additional u or d suffixes, indicating to which side (up or down) they apply.

---

### *Electrolyte Potential*

---

Add the **Electrolyte Potential** node from **Electrolyte** submenus for boundaries, edges, and points to set a fixed potential at a position in the electrolyte. This node can be used to model half-cells, or to set the electrolyte potential at the position of, for example, a reference electrode.

The node sets the potential in the electrolyte,  $\phi_L$ , to be equal to the **Boundary electrolyte potential**,  $\phi_{L, \text{ bnd}}$  (SI unit: V).

By right-clicking this node you can add a [Harmonic Perturbation](#) subnode.

## CONSTRAINT SETTINGS

To display this section, click the **Show More Options** button (  ) and select **Advanced Physics Options** in the **Show More Options** dialog.

### *Electrolyte Current*

---

The **Electrolyte Current** boundary condition sets the total current or average current density of a boundary. The condition sets the total inward current without imposing the current density distribution. It will set a constant electrolyte potential along the given boundary, that satisfies the current value setting.

When using the **Total current** option in 1D or 2D, the boundary area is based either on the **Cross-sectional area** (1D) or the **Out-of-Plane thickness** (2D) properties, set on the physics interface top node.

## CONSTRAINT SETTINGS

To display this section, click the **Show More Options** button (  ) and select **Advanced Physics Options** in the **Show More Options** dialog.



- [Electrolyte Current Theory](#)
- 

### *Electrolyte Current Density*

---

Use the **Electrolyte Current Density** node to specify the current density distribution along a boundary.

Note that using this node in 2D or 3D may result in an uneven potential distribution along the boundary. To mitigate such effects you can use the [Electrode Current](#) node instead.

By right-clicking this node you can enable **Harmonic Perturbation**. This means that the node will only be active when solving for Frequency Domain study steps (typically used in AC Impedance studies). The frequency spectrum is specified in the study node.

### *Thin Electrode Layer*

---

The **Thin Electrode Layer** node can be used to model a thin insulating or resistive sheet, located on an interior boundary in an electrode domain. The node can be used as an

alternative to drawing the actual layer domain in the model geometry, which may significantly reduce meshing and solver time, especially in 3D models.

A thin electrode layer can be used to model, for instance, a contact impedance between two electronic conductors.

The layer can be set to be either **Insulating** or **Resistive**.

For the case of **Resistive**, the **Surface Resistance** can either be set directly, or calculated from **Thickness and Conductivity** values.

#### **ADVANCED SETTINGS**

Enable **Slit electrolyte potential in porous electrodes** to make the layer fully insulating for the electrolyte phase potential along the selected boundaries.

#### *Electrode–Electrolyte Boundary Interface*

---

Note that this is an advanced physics feature that is normally not used. To display this feature in the context menu, click the **Show More Options** button (  ) and then select **Advanced Physics Options** in the **Show More Options** dialog. Then add the **Electrode–Electrolyte Boundary Interface** node from the **Electrode** or **Pairs > Electrode** submenu.

Use this node to model an electrochemical interface between an electrolyte and an electrode where the electrolyte domain is not included explicitly in the model. The node can only be applied on outer boundaries to electrode domains. Set the potential of the electrolyte either explicitly, or specify a current condition that the potential of the electrode shall fulfill.

[Electrode Reaction](#) and [Double-Layer Capacitance](#) subnodes are available from the context menu (right-click the parent node) or from the **Physics** toolbar, **Attributes** menu.

This node is available for the Secondary Current Distribution and Tertiary Current Distribution, Nernst–Planck interfaces.

#### **BOUNDARY CONDITION**

This section specifies the potential of the electrolyte phase for the electrolyte-electrode interface. The electrolyte potential is used (via the overpotential) by the **Electrode Reaction** subnodes.

The **Electrolyte potential** will set the potential value directly, whereas **Total current** or **Average current density** both add an extra global degree of freedom for the potential in the electrolyte phase, set to comply with the chosen condition.

When using the **Total current** option in 1D or 2D, the boundary area is based either on the **Cross-sectional area** (1D) or the **Out-of-Plane thickness** (2D) properties, set on the physics interface top node.

### *Electric Ground*

---

This node to sets the electric potential to zero.

The node is typically used to ground the voltage at an exterior boundary in a model that contains either electrode or porous electrode domains.

#### **CONTACT RESISTANCE**

Enabling **Include contact resistance** allows for a **Contact resistance**  $R_c$  (SI unit:  $\Omega \cdot \text{m}^2$ ) to be specified and the following current density condition is used:

$$-\mathbf{n} \cdot \mathbf{i}_s = \frac{-\phi_s}{R_c}$$

#### **CONSTRAINT SETTINGS**

To display this section, click the **Show More Options** button (  ) and select **Advanced Physics Options** in the **Show More Options** dialog.

### *Electric Potential*

---

This node sets the electric potential in the electrode (or a porous electrode),  $\phi_s$ , to a value,  $\phi_{s,\text{bnd}}$  according to the following:

$$\phi_s = \phi_{s,\text{bnd}}$$

The node is typically used to set the cell voltage at an exterior boundary in a model that contains either electrode or porous electrode domains.

#### **CONTACT RESISTANCE**

Enabling **Include contact resistance** allows for a **Contact resistance**  $R_c$  (SI unit:  $\Omega \cdot \text{m}^2$ ) to be specified and the following current density condition is used:

$$-\mathbf{n} \cdot \mathbf{i}_s = \frac{\phi_{s,\text{bnd}} - \phi_s}{R_c}$$

By right-clicking this node you can add a [Harmonic Perturbation](#) subnode.

### CONSTRAINT SETTINGS

To display this section, click the **Show More Options** button (  ) and select **Advanced Physics Options** in the **Show More Options** dialog.

#### *Electrode Current Density*

---

The **Electrode Current Density** boundary condition can be applied at an exterior boundary of a model that contains either electrode or porous electrode domains.

Note that using this node in 2D or 3D may result in an uneven potential distribution along the boundary. To mitigate such effects you can use the [Electrode Current](#) node instead.

By right-clicking this node you can enable **Harmonic Perturbation**. This means that the node will only be active when solving for Frequency Domain study steps (typically used in AC Impedance studies). The frequency spectrum is specified in the study node.

#### *Electrode Current*

---

Use the **Electrode Current** node to set the total current or average current density over an external electrode or porous electrode boundary — typically at the interface between the electrode and the current collector or current feeder. The condition sets the total inward current without imposing the current density distribution. The potential along the boundary is calculated in order to satisfy the total value of the current.

In the Lithium-Ion Battery and the Battery with Binary Electrolyte interfaces, if the **Define cell state of charge (SOC) and initial charge inventory** checkbox has been ticked in the Cell Settings section on the physics interface top node, the **Total current** can be specified either explicitly or as a multiple of the C-rate current variable (`xxx.I_1C_cell`, where `xxx` is the physics interface tag) that is defined by the global [SOC and Initial Charge Distribution](#) node.

When using the **Total current** option in 1D or 2D, the boundary area is based either on the **Cross-sectional area** (1D), or the **Out-of-Plane thickness** (2D) properties, set on the physics interface top node.

### CONTACT RESISTANCE

Enabling **Include contact resistance** allows for a **Contact resistance**  $R_c$  (SI unit:  $\Omega\cdot\text{m}^2$ ) to be specified.

### CONSTRAINT SETTINGS

To display this section, click the **Show More Options** button (  ) and select **Advanced Physics Options** in the **Show More Options** dialog.



• [Electrode Current Theory](#)

---

### *Electrode Power*

---

The **Electrode Power** boundary condition sets the power drawn from, or inserted to, an electrical cell at external electrode boundary.

When using the **Total power** option in 1D or 2D, the boundary area is based either on the **Cross-sectional area** (1D), or the **Out-of-Plane thickness** (2D) properties, set on the physics interface top node.

### CONTACT RESISTANCE

Enabling **Include contact resistance** allows for a **Contact resistance**  $R_c$  (SI unit:  $\Omega\cdot\text{m}^2$ ) to be specified.



[Electrode Power Theory](#)

---

### *Harmonic Perturbation*

---

Use the **Harmonic Perturbation** subnode to specify the voltage amplitude perturbation in the frequency domain. The harmonic perturbation is only applied when solving for a Frequency Domain study type, which is typically used in AC Impedance studies.

The **Harmonic Perturbation** subnode can be added to the [Electric Potential](#), [Electrolyte Potential](#). The subnode is available from the context menu (right-click the parent node) or from the **Physics** toolbar in the **Contextual** group.

The frequency spectrum is specified in the study node.

You can also specify harmonic perturbations to the [Electrode Current Density](#), [Electrolyte Current Density](#) and [Electrode Surface](#) nodes.



## Frequency-Domain Perturbation Study Step in the *COMSOL Multiphysics Reference Manual*

### *Electrode Potential*

Use the **Electrode Potential** node to set a boundary condition for the electric potential with respect to a defined reference potential.

Electric potentials defined by the [Electric Reference Potential](#) and [Reference Electrode](#) point nodes can be used as input when specifying the **Electric reference potential**  $\phi_{vs,ref}$  (SI unit: V).

#### **CONSTRAINT SETTINGS**

To display this section, click the **Show More Options** button (  ) and select **Advanced Physics Options** in the **Show More Options** dialog.



## Electrode Potentials and Reference Electrodes

### *External Short*

Use the **External Short** node to connect two electrodes over an external connector with a given **Resistance**  $R$  (SI unit: ohm).

The boundary selected in the External Short node will be set to a constant potential,  $\phi_{s,here}$ , and the integrated current over the boundary will be computed according to Ohm's law:

$$\phi_s = \phi_{s,here}$$
$$\phi_{s,here} : \int_{d\Omega} (\mathbf{n} \cdot \mathbf{I}_s) d\Omega = -\frac{\phi_{s,here} - \phi_{s,there}}{R}$$

where  $\phi_{s,there}$  (V) is the potential of the connected electrode. Use the **Connected Potential** list to choose among available connection potentials for the value of  $\phi_{s,there}$ .

### *Initial Values for Adsorbing–Desorbing Species*

---

The node sets the initial values for the surface coverage of adsorbing–desorbing species dependent variables.

This node is available as a subnode for the Electrode Surface, Perforated Electrode Surface and [Internal Electrode Surface](#). The node is not available if no adsorbing–desorbing species are present in the parent node.

### *Reference Electrode*

---

The **Reference Electrode** node is a point feature applicable to electrolyte domains. It defines a global electric reference potential and can be used in the [Electrode Potential](#) node for setting the electric potential of an electrode boundary with respect to the reference potential.

#### **EQUILIBRIUM POTENTIAL**

See [Electrode Reaction](#) for information about the settings of this section.



[Electrode Potentials and Reference Electrodes](#)

---

### *Electric Reference Potential*

---

The **Electric Reference Potential** node is a point feature applicable to electrode domains. It defines a global electric reference potential equal to the electric potential in the point and can be used in the [Electrode Potential](#) feature for setting the electric potential of an electrode boundary with respect to the reference potential.



[Electrode Potentials and Reference Electrodes](#)

---

### *Load Cycle*

---

Use the **Load Cycle** node to specify a generic load cycling boundary condition in time-dependent simulations, where the switch between charge and discharge depends on the resulting cell voltage, current, elapsed time, or user-defined conditions.

The cycle is defined by adding [Current](#), [Voltage](#), and [Rest](#) child nodes.

The node is available as boundary node applicable to exterior boundaries to electrode domains, or is activated as a child node to an [Electrode Surface](#), a [Perforated Electrode Surface](#) or a [Highly Conductive Porous Electrode](#) parent node when the **Load Cycle** electrode phase potential condition has been selected on the parent node.

The Load Cycle node should typically be applied on the positive side of the cell.

#### LOAD TYPE

When a Load Cycle node is applied on the exterior boundary to an electrode domain, the **Load type** can be set to either **Galvanostatic**, **Potentiostatic**, or **Potentiostatic and galvanostatic**. When the node is active as a child node to an [Electrode Surface](#), a [Perforated Electrode Surface](#) or a [Highly Conductive Porous Electrode](#) parent node, the load cycle can be set to either **Potentiostatic** or **Potentiostatic and galvanostatic**.

For **Galvanostatic**, only Current, Rest, and Subloop child nodes can be added to the Load Cycle.

For **Potentiostatic** only Voltage and Subloop child nodes can be added to the Load Cycle.

For **Potentiostatic and galvanostatic**, all child nodes are available for defining the load cycle. However, the **Potentiostatic and galvanostatic** option is implemented by adding an additional dependent variable, which in some cases may be a less stable option than **Galvanostatic** or **Potentiostatic**.

#### CONTINUATION CONDITIONS

The switching between the load conditions, as specified by the child nodes, is defined internally by the use of solver events.

Enabling **Use elapsed time only** will define all events as explicit in time, which usually is a more accurate option.

Disabling **Use elapsed time only** will define all events as implicit events, which supports dynamic load switching based on voltage, current and user-defined conditions. **Use elapsed time only** does not support Subloop child nodes.

#### CYCLING STOP CONDITION

The cycling stop condition can be used to define when the load cycle should be terminated. Use the condition **None** (the default) to loop over the added child nodes indefinitely.

When the stop condition is fulfilled, the applied current is set to 0 for the **Potentiostatic and galvanostatic** and **Galvanostatic** load cycle options, whereas for the **Potentiostatic** option event switching between the voltage set values is halted. Check **Enable stop condition in default solver** to also stop the time-dependent solver at this point in the simulation.

A **User defined** condition can be used to trigger a cycling termination based on the value of any globally available expression in the model. The transition will be defined to occur when the  $\text{Ind}_{\text{user}}$  expression switches from negative to positive. For instance, to define a temperature-dependent continuation condition to occur when the maximum temperature variable  $T_{\text{max}}$  exceeds 50 [degC], define  $\text{Ind}_{\text{user}}$  as  $T_{\text{max}} - 50[\text{degC}]$ . (Here,  $T_{\text{max}}$  can for instance be a variable defined using a **Definitions > Nonlocal Couplings > Maximum** operator on a domain.)

### PROBES

By enabling the **Applied voltage** and **Applied current** checkboxes, the corresponding probes are automatically defined under **Definitions** in the model tree.

By default, the probe variables values will be automatically stored in a table and plotted during solving.

These probe options are not available when the Load cycle node is used as a child node to the **Electrode Surface** and related nodes.

### *Current, Voltage, and Rest*

---

The **Current**, **Voltage**, and **Rest** nodes can be added as child nodes to a **Load Cycle** node.

If the **Load type** has been set to **Galvanostatic** on the parent Load Cycle node, the **Voltage** is not available.

If the **Load type** has been set to **Potentiostatic** on the parent Load Cycle node, only the **Voltage** node is available.

### CURRENT OR VOLTAGE SETTINGS

The settings of this section defines the set value in the unit of either A or V, respectively. The section is not available for the **Rest** node, which sets the current to 0 A at all times.

The **Input type** can be set to either **Value**, **Function**, or **Step sequence**.

For **Function**, any available function defined under **Definitions** or **Global Definitions** can be used. The set value will be defined to equal the function value, using the time elapsed since the activation of the node as argument.

The **Step sequence** option allows for defining a table of times at which the set value should be changed to a new value. The switching to the table set values is achieved by the use of automatically defined events, defined to be triggered when the elapsed time since activation of the node equals the correspondingly defined time settings values. Upon activation of the node, the set value is set to the **Initial voltage/current** value.

### CONTINUATION CONDITIONS

This section specifies when the cycle should proceed to the next node at the same level in the model tree, or to the first node, if the present node is the last. The **Elapsed time** condition is the only available continuation condition if **Use elapsed time only** has been enabled on the parent Load Cycle node, otherwise multiple conditions, internally defined using implicit solver events, can be enabled.

The **Elapsed time** condition can be used to proceed to the next node after a certain time, counted from the activation of the node. (This is the default condition for the **Rest** node.)

The **Maximum voltage** and **Minimum voltage** conditions can be used to proceed to the next node when the voltage reaches or goes below a certain threshold, respectively. The **Maximum voltage** condition is typically used for a **Current** charging step, whereas the **Minimum voltage** condition is typically used for a **Current** discharging step. (These conditions are not available for the **Voltage** node.)

The **Maximum current** and **Minimum current** conditions can be used to proceed to the next node when the current reaches or goes below a certain threshold, respectively. The **Maximum current** condition, is typically specified, using a small negative value for a **Voltage** discharging step. The **Minimum current** condition is typically used for **Voltage** charging steps. (These conditions are not available for the **Current** and **Rest** nodes.)

A **User defined** condition can be used to trigger a transition to the subsequent node based on the value of any globally available expression in the model. The transition will be defined to occur when the  $\text{Ind}_{\text{user}}$  expression switches from negative to positive. For instance, to define a temperature-dependent continuation condition to occur when the maximum temperature variable  $T_{\text{max}}$  exceeds  $50[\text{degC}]$ , define  $\text{Ind}_{\text{user}}$  as  $T_{\text{max}} - 50[\text{degC}]$ . (Here,  $T_{\text{max}}$  can for instance be a variable defined using a **Definitions > Nonlocal Couplings > Maximum** operator on a domain.)



## *Circuit Terminal*

---

This feature is only available with an AC/DC Module or a Battery Design Module license.

Use the **Circuit Terminal** node to specify a coupling to the **External I vs. U** node in the **Electrical Circuit** interface.

# The Aqueous Electrolyte Transport Interface

The **Aqueous Electrolyte Transport (aqt)** interface () , found under the **Electrochemistry** branch () , is used to solve for the mass transport of an arbitrary number of species in water-based systems subject to potential gradients. The species transported can be any combination of weak and strong acids and bases, ampholytes, and uncharged species. The transport of mass and charge is based on the Nernst–Planck equations for molecular transport, in combination with electroneutrality and dissociation equilibria for weak acids, bases, and ampholytes as well as the water autoionization reaction.

The physics interface can simulate mass transport in aqueous electrolyte systems containing several equilibrium reactions, which is the case in, for instance, atmospheric corrosion.

The interface supports simulation in 1D, 2D, and 3D as well as for axisymmetric components in 1D and 2D.

The dependent variables are the electrolyte phase potential and the molar concentrations of the included species, added individually by each species node at the electrolyte node.

## SETTINGS

The **Label** is the default physics interface name.

The **Name** is used primarily as a scope prefix for variables defined by the physics interface. Refer to such physics interface variables in expressions using the pattern `<name>.<variable_name>`. In order to distinguish between variables belonging to different physics interfaces, the **name** string must be unique. Only letters, numbers, and underscores (`_`) are permitted in the **Name** field. The first character must be a letter.

The default **Name** (for the first physics interface in the model) is `aqt`.

## DOMAIN SELECTION

If any part of the model geometry should not partake in the mass transfer model, remove that part from the selection list.

## OUT-OF-PLANE THICKNESS



For 2D components, enter a value or expression for the **Out-of-Plane Thickness**  $d_z$  (SI unit: m). The value of  $d_z$  determines the size of the domain perpendicular to the modeled 2D cross section. This value yields, for example, the correct total current when the current density is obtained from a 2D simulation.

## CROSS-SECTIONAL AREA



For 1D components, enter a **Cross-Sectional Area**  $A_c$  (SI unit:  $\text{m}^2$ ) to define a parameter for the area of the geometry perpendicular to the 1D component. The value of this parameter is used to, among other things, automatically calculate the total current from the current density vector. The analogy is valid for other fluxes. The default is  $1 \text{ m}^2$ .

The **Include out-of-plane thickness in the time derivative in material balances** (or **Include cross-sectional area in time derivative in material balances**) checkbox (depending on component dimension) is by default selected. When selected, any time-dependent out-of-plane expansion or contraction will change the species concentration in the domain. Since the concentration is uniform in the out-of-plane direction, this setting can be useful to simulate thin films that grow or shrink; for instance, water evaporation or condensation.

## TRANSPORT MECHANISMS

Mass transport due to diffusion and migration is included by default. If the **Solve for electrolyte phase potential** checkbox is cleared, the potential can be set manually to a constant value (the default is 0 V) in the **Electrolyte** node.

Use the checkbox available under **Additional transport mechanisms** to control convective transport. By default, the **Convection** checkbox is cleared.

### CONSISTENT STABILIZATION

To display this section, click the **Show More Options** button (  ) and select **Stabilization** in the **Show More Options** dialog.

- When the **Crosswind diffusion** checkbox is selected, a weak term that reduces spurious oscillations is added to the transport equation. The resulting equation system is always nonlinear.
- For both **Streamline diffusion** and **Crosswind diffusion**, the **Equation residual** is always **approximate**. Derivatives of the diffusivity are thus neglected.

### INCONSISTENT STABILIZATION

To display this section, click the **Show More Options** button (  ) and select **Stabilization** in the **Show More Options** dialog. By default, the **Isotropic diffusion** checkbox is not selected because this type of stabilization adds artificial diffusion and affects the accuracy of the original problem. However, this option can be used to get a good initial guess for under-resolved problems.

### ADVANCED SETTINGS

To display this section, click the **Show More Options** button (  ) and select **Advanced Physics Options** in the **Show More Options** dialog. Normally these settings do not need to be changed. Select a **Material Balance Form** — **Nonconservative** (the default) or **Conservative**. Use the conservative formulation for compressible flow. Note that the setting not only dictates the convective term but also the accumulation term in the material balance for porous media.

### DISCRETIZATION

To display all settings available in this section, click the **Show More Options** button (  ) and select **Advanced Physics Options** in the **Show More Options** dialog.

The concentration variables are set to use **Linear** elements by default.

The potential variable is set to use **Quadratic** elements by default.

The **Compute boundary fluxes** checkbox is activated by default so that COMSOL Multiphysics computes predefined accurate boundary flux variables. When this option is checked, the solver computes variables storing accurate boundary fluxes from each boundary into the adjacent domain.

If the checkbox is cleared, the COMSOL Multiphysics software instead computes the flux variables from the dependent variables using extrapolation, which is less accurate

in postprocessing results but does not create extra dependent variables on the boundaries for the fluxes.

The flux variables affected in the interface are:

- `<name>.nI1`, where `<name>` is the name of the interface (default is `e1`), set on the interface top node. This is the normal electrolyte current density.
- `<name>.ntflux_<species_name>` is the **Species name** (see [Species Nodes in the Aqueous Electrolyte Transport Interface](#) below). This is the normal total flux for each species.

Also the **Apply smoothing to boundary fluxes** checkbox is available if the previous checkbox is checked. The smoothing can provide a more well-behaved flux value close to singularities.

For details about the boundary fluxes settings, see [Computing Accurate Fluxes](#) in the *COMSOL Multiphysics Reference Manual*.

Regarding the **Value type when using splitting of complex variables**, see [Splitting Complex-Valued Variables](#) in the *COMSOL Multiphysics Reference Manual*.

#### DEPENDENT VARIABLES

The dependent variable name for the electrolyte potential variable is `aqt.ph11` by default.

The concentration-dependent variables are named as `aqt.xxx`, where `aqt` is the name of the interface as set above, and the `xxx` string is controlled by the **Species name** setting on the individual species nodes.

#### FURTHER READING

- 
- [Theory for the Aqueous Electrolyte Transport Interface](#)
  - [Numerical Stabilization](#) in the *COMSOL Multiphysics Reference Manual*.
- 
- In the *COMSOL Multiphysics Reference Manual*, see [Table 2-4](#) for links to common sections and [Table 2-5](#) for common feature nodes. You can also search for information: press F1 to open the **Help** window or Ctrl+F1 to open the **Documentation** window.
-

## *Species Nodes in the Aqueous Electrolyte Transport Interface*

---

The interface features the following species nodes and are added at the [Electrolyte](#) node:

- [Ampholyte](#)
- [Fully Dissociated Species](#)
- [Uncharged Species](#)
- [Weak Acid](#)
- [Weak Base](#)
- [Carbonic Acid](#)
- [Complex Species](#)

The [Ampholyte](#), [Weak Acid](#), [Weak Base](#), and [Carbonic Acid](#) nodes are dissociation species and can define an arbitrary number of dissociation steps. Each dissociation step is defined by its  $pK_a$  (the acid equilibrium constant) parameter. For the weak bases the  $pK_a$  refers to the acid constant of the conjugate acid. Each dissociation step adds one additional subspecies concentration variable so that the concentration dependent variable represents the sum of all subspecies, and initial and boundary conditions are defined with respect to this total concentration.

All species node have a setting for the **Species name**, which needs to be unique. The species name is used for naming of all related variables of the species. For species nodes not defining any subspecies, the concentration variables are named as `<name>.c_<species_name>` where `<name>` is the name of the interface (default is `e1`), set on the interface top node, and `<species_name>` is the **Species name**. For dissociation species nodes defining multiple subspecies, the concentration nodes are named as `<name>.c<X>_<species_name>` where `<X>` is the integer from 1 up to the total number of subspecies. Note that the [Electrolyte](#) node automatically defines the concentration variables for protons (`<name>.cH`) and hydroxide ions (`<name>.cOH`).

All species except the [Uncharged Species](#) carry charge and contribute to the total electrolyte current which is used in the equation for solving the electrolyte potential.

The **Immobile Species** checkbox can be used to lock the concentration of a species, to, for instance, define the immobile charges in an ion-selective membrane or a gel. When the checkbox is enabled the concentration of the species is not added as a dependent variable to the model; instead the concentration will be set to the value provided in the **Concentration** field. The contribution to the electrolyte current for immobile species is zero.

## *Diffusion and Migration Settings*

---

All species, except when the **Immobile Species** checkbox has been enabled, can be transported by diffusion, and charged species are also transported by migration in the electric field.

For dissociation species you can choose to set the transport parameters to be the **Same for all species** appearing in the different dissociation steps, or you can use **Individual** settings for each subspecies. An exception is the **Carbonic Acid** node that only accounts for Individual subspecies.

The species diffusivity can either be related to the mobility by the **Nernst–Einstein relation** (default) or user defined values can be set using the **No relation** alternative.

---

**Note:** There are other definitions of the migration transport equations in the literature which use mobilities expressed in  $\text{m}^2/(\text{V}\cdot\text{s})$ , whereas COMSOL Multiphysics uses  $\text{s}\cdot\text{mol}/\text{kg}$ . To convert mobilities expressed in  $\text{m}^2/(\text{V}\cdot\text{s})$  to the corresponding values in  $\text{s}\cdot\text{mol}/\text{kg}$ , you typically divide by the Faraday constant,  $F_{\text{const}}$  (about 96,485 C/mol).

---

## *Domain, Boundary, and Pair Nodes for the Aqueous Electrolyte Transport Interface*

---

The interface has the following domain, boundary, and pair nodes, listed in alphabetical order, available from the **Physics** ribbon toolbar (Windows users), **Physics** context menu (Mac or Linux users), or by right-clicking to access the context menu (all users).



To add a node, go to the **Physics** toolbar, no matter what operating system you are using. Subnodes are available by clicking the parent node and selecting it from the **Attributes** menu.

---

- Ampholyte
- Carbonic Acid
- Complex Species
- Electrolyte
- Electrode Reaction
- Electrode Surface
- Flux
- Fully Dissociated Species
- Highly Conductive Porous Electrode
- Inflow
- Initial Values
- No Flux
- Outflow
- Porous Electrode Reaction
- Potential
- Reaction
- Reservoir
- Separator
- Species Source
- Uncharged Species
- Weak Acid
- Weak Base



For axisymmetric components, COMSOL Multiphysics takes the axial symmetry boundaries (at  $r = 0$ ) into account and automatically adds an **Axial Symmetry** node that is valid on boundaries representing the symmetry axis.



In the *COMSOL Multiphysics Reference Manual*, see [Table 2-4](#) for links to common sections and [Table 2-5](#) for common feature nodes. You can also search for information: press F1 to open the **Help** window or Ctrl+F1 to open the **Documentation** window.

### *Electrolyte*

The settings of this node are used to define the properties of the aqueous solvent.

If **Convection** is enabled on the interface top node, you can specify the **Velocity field** (m/s) as user-defined input using analytical expressions or the velocity field variables solved for by a separate physics interface.

The **Electrolyte** node automatically defines the concentration variables for protons (<name>.cH) and hydroxide ions (<name>.cOH), and the corresponding flux expressions.

In the **Proton and Hydroxide Ion Transport Properties** section you can modify the **Diffusivity–mobility relation** either by selecting the **Nernst–Einstein relation** (default) or entering values manually (**No relation**).

In the **Water Self-ionization** section you can change the default **Built in** expression for the **Water self-ionization constant**,  $pK_w$  (unitless), to any user-defined expression.

### *Fully Dissociated Species*

---

Use this node to define a fully dissociated charged species, such as strong bases and acids.

The **Charge number**,  $z$  (unitless), defines the species charge.

See also [Species Nodes in the Aqueous Electrolyte Transport Interface and Diffusion and Migration Settings](#).

### *Uncharged Species*

---

Use this node to define a species that does not carry any charge, nor is impacted by the electric field.

See also [Species Nodes in the Aqueous Electrolyte Transport Interface and Diffusion and Migration Settings](#).

### *Weak Acid*

---

The **Weak Acid** node supports multiple dissociation steps, where the acid of the first dissociation step is uncharged.

The species can be either **Monoprotic**, subject to one dissociation step only, or **Polyprotic**. For the latter case, any positive integer can define the **Number of dissociation steps**.

See also [Species Nodes in the Aqueous Electrolyte Transport Interface and Diffusion and Migration Settings](#).

### *Weak Base*

---

The **Weak Base** node supports multiple dissociation steps, where the base of the last dissociation step is uncharged.

The species can be either **Monoprotic**, subject to one dissociation step only, or **Polyprotic**. For the latter case, any positive integer can define the **Number of dissociation steps**.

Note that the  $\text{p}K_a$  refers to the acid constant of the conjugate acid of the weak base.

See also [Species Nodes in the Aqueous Electrolyte Transport Interface and Diffusion and Migration Settings](#).

### *Ampholyte*

---

Use the **Ampholyte** node generically to define any species where the average charge depends on the pH of the solution. The **Dissociation model** can be based either on a set of **Equilibrium constants** or an **Average charge**.

When using the **Equilibrium constants** the **Base charge in last dissociation step**,  $z_0$  (unitless), needs to be set and be defined as an integer.

The **Average charge**,  $\bar{z}$  (unitless) parameter is typically a function of pH and can be added as an analytical function or an interpolation polynomial under **Definitions**. The average squared charge, used in the electrolyte potential equation, is calculated automatically based on  $\bar{z}$ .

See also [Species Nodes in the Aqueous Electrolyte Transport Interface and Diffusion and Migration Settings](#).

### *Carbonic Acid*

---

Use the **Carbonic Acid** node to define all carbon dioxide species in contact with water ( $\text{CO}_2(\text{aq})$ ,  $\text{H}_2\text{CO}_3$ ,  $\text{HCO}_3^-$ , and  $\text{CO}_3^{2-}$ ). The node automatically sets up equilibrium reactions and mass transport properties.

For the  $\text{p}K_a$  there is two options: **Built in** (default), which offers temperature dependent values for carbonic acid in pure aqueous solution, or **User defined**, which lets you set values of your choice.

See also [Species Nodes in the Aqueous Electrolyte Transport Interface and Diffusion and Migration Settings](#).

## *Complex Species*

---

The **Complex Species** node is available when at least one species node (with the **Immobile species** checkbox cleared) has been added to the **Electrolyte** node. The node can be used to model any complex formed by the available species in the aqueous electrolyte.

Set the **Diffusion coefficient**,  $D$ , (default is  $10^{-9}$  m<sup>2</sup>/s) of the complex species and the **Equilibrium constant**,  $K_{\text{eq}}$ , (default is 1) for the reaction forming the complex.

In the **Stoichiometric Coefficients** section select the checkboxes of the species forming the complex and set the stoichiometric coefficients (default is zero). Only values lower than or equal to zero are allowed.

## *Highly Conductive Porous Electrode*

---

Use this node to define a porous electrode that has electrolyte-filled pores and a highly conductive electron phase with potential gradients considered to be negligible.

In the **Porous Matrix Properties**, the porosity and tortuosity (available depending on transport correction setting) can be adjusted from the default values that for both properties are 1.

In the **Effective Transport Parameter Correction** section, the mass transport correction in the porous media is defined. The default correction is **Bruggeman**, which multiplies the diffusivity and mobility values by the porosity to the power of 1.5. Other available corrections are **Tortuosity**, **User defined**, or **No correction**.

Use the **Harmonic Perturbation** section in conjunction with AC Impedance study types to control the perturbation amplitude in the frequency domain. The perturbation parameter is either **Electric potential** or **Total current** based on the **Electrode phase potential condition** selected in the next section.

### **ELECTRODE PHASE POTENTIAL CONDITION**

This section specifies the potential in the electrode phase of the electrolyte-electrode interface. The electrode potential is used (via the overpotential) by the [Porous Electrode Reaction](#) subnodes.

Use the **Electric potential** option (default) to set the value of the potential explicitly with respect to ground. The other option, **Total current**, adds an extra global degree of freedom for the potential in the electrode phase, set to comply with the chosen condition. When using the **Total current** option in 1D or 2D, the boundary area is

based either on the **Cross-Sectional Area** (1D), or the **Out-of-Plane Thickness** (2D) properties, set on the physics interface top node.

### ADSORBING–DESORBING SPECIES

Use the settings of this section to define species that can adsorb or desorb on the electrode surface.

The **Density of sites** parameter will be used to set up the local surface mass balance equations for the fractional surface coverages.

Use the **Add** ( + ) and **Delete** ( ≡ ) buttons as needed in the table to control the number of species. The name of each adsorbing–desorbing **Species** can be edited in the first column of the table.

The **Stoichiometric Coefficients** section in the [Porous Electrode Reaction](#) and [Reaction](#) subnodes is used to set the stoichiometric coefficients for adsorbing–desorbing species reaction.

### *Porous Electrode Reaction*

---

The **Porous Electrode Reaction** node defines the electrode kinetics for a charge transfer reaction that occurs at the interface between the electrolyte and the electrode matrix in a porous electrode. The node can be added as a subnode to a **Highly Conductive Porous Electrode** node. Add multiple nodes to the same **Highly Conductive Porous Electrode** node to model multiple reactions, for instance in mixed potential problems.

See the [Electrode Reaction](#) node for a description of the **Equilibrium Potential**, **Electrode Kinetics**, **Stoichiometric Coefficients**, and **Heat of Reaction** sections.

### ACTIVE SPECIFIC SURFACE AREA

The **Active Specific Surface Area**,  $a_v$  (SI unit:  $\text{m}^2/\text{m}^3$ ) specifies the area of the electrode-electrolyte interface that is catalytically active for this porous electrode reaction.  $a_v$  is multiplied by  $i_{\text{loc}}$ , defined in the [Electrode Kinetics](#) section, to produce a current source in the domain. The default value is  $10^6$  1/m.

## *Separator*

---

Use this node at domains that have **Porous Matrix Properties**, that is, porosity and tortuosity. Both the porosity and tortuosity (available depending on transport correction setting) are by default set to 1.

In the **Effective Transport Parameter Correction** section, the mass transport correction in the porous media is defined. The default correction is **Bruggeman**, which multiplies the diffusivity and mobility values by the porosity to the power of 1.5. Other available corrections are **Tortuosity**, **User defined**, or **No correction**.

## *Initial Values*

---

Use this node to specify the **Initial Values** of the electrolyte potential and the concentrations of the added species nodes.

The set values serve as the initial condition for a transient simulation. These also serve as start guesses for stationary problems. You can use additional **Initial Values** nodes and modify the **Selection** to set different values for different domains.



In the case of weak acid, weak base, and ampholyte species, the total of the dissociated species concentrations is only required. If [Complex Species](#) nodes have been added, the complex species concentrations are computed and subtracted from the complex-forming species automatically.

## *Electrode Surface*

---

Use the **Electrode Surface** node to model an electrochemical electrode-electrolyte interface between an electrolyte domain and an electrode boundary where the electrode is not included explicitly as a domain in the model geometry.

Use the **Harmonic Perturbation** section in conjunction with AC Impedance study types to control the perturbation amplitude in the frequency domain. The perturbation parameter is either **Electric potential** or **Total current** based on the **Electrode phase potential condition** selected in the next section.

## ELECTRODE PHASE POTENTIAL CONDITION

This section specifies the potential in the electrode phase of the electrolyte-electrode interface. The electrode potential is used (via the overpotential) by the [Electrode Reaction](#) subnodes.

Use the **Electric potential** option (default) to set the value of the potential explicitly with respect to ground. The other option, **Total current**, adds an extra global degree of freedom for the potential in the electrode phase, set to comply with the chosen condition. When using the **Total current** option in 1D or 2D, the boundary area is based either on the **Cross-Sectional Area** (1D), or the **Out-of-Plane Thickness** (2D) properties, set on the physics interface top node.

## ADSORBING-DESORBING SPECIES

Use the settings of this section to define species that can adsorb or desorb on the electrode surface.

The **Density of sites** parameter will be used to set up the local surface mass balance equations for the fractional surface coverages.

Use the **Add** ( + ) and **Delete** (  ) buttons as needed in the table to control the number of species. The name of each adsorbing-desorbing **Species** can be edited in the first column of the table.

The **Stoichiometric Coefficients** section in the [Electrode Reaction](#) and [Reaction](#) subnodes is used to set the stoichiometric coefficients for adsorbing-desorbing species reaction.

### *Electrode Reaction*

---

The **Electrode Reaction** node defines the electrode kinetics for a charge transfer reaction that occurs on an electrolyte-electrode interface boundary.

The node can be added as a subnode to an **Electrode Surface** node. Add multiple nodes to the same **Electrode Surface** node to model multiple reactions, for instance in mixed potential problems.

### STOICHIOMETRIC COEFFICIENTS

Specify the **Stoichiometric coefficient** ( $v_{c1}$ ,  $v_{c2}$ , and so forth) for each of the involved species according to the following generic electrochemical reaction:

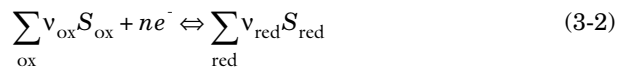

Set  $v_i$  as positive ( $v_{\text{red}}$ ) for the reduced species and negative ( $v_{\text{ox}}$ ) for the oxidized species in an electrochemical reaction. The number of participating electrons,  $n$ , is computed using the sum of all reacting species charges and accounting for the sign convention of the stoichiometric coefficients:

$$n = -\sum_i z_i v_i \quad (3-3)$$



An easy way to determine the stoichiometric coefficients for a reaction is to write the reaction as a reduction reaction (with the electrons on the left), irrespectively on the expected actual direction of the reaction in the model. The species on the left side then have negative coefficients and the species on the right have positive coefficients.

### EQUILIBRIUM POTENTIAL

The **Equilibrium potential**,  $E_{\text{eq}}$  (SI unit: V), is used in the electrode kinetics expressions in the Electrode Kinetics section (via the definition of the overpotential), or for setting up primary current distribution potential constraints.

The equilibrium potential can be defined either in the Materials node (**From material**), by using the **Nernst Equation**, or by using a **User defined** expression.

If the Nernst Equation is used, the concentration dependence is calculated automatically based on the **Reference equilibrium potential**  $E_{\text{eq,ref}}$  (V).

When using Nernst Equation, additional options are available in the **Butler–Volmer** expression type in the Electrode Kinetics section.

### REFERENCE CONCENTRATIONS

This section is only available, if the equilibrium potential has been selected to be defined by the **Nernst Equation**.

The reference concentrations define the reference state for which

$$E_{\text{eq}} = E_{\text{eq,ref}}$$

## ELECTRODE KINETICS

The settings of this section will define the local current density,  $i_{\text{loc}}$  (SI unit:  $\text{A}/\text{m}^2$ ), at the interface between the electrolyte and the electrode. Note that  $i_{\text{loc}}$  for all built-in kinetics expression types will depend on the overpotential, which in turn depend on the Equilibrium potential defined in the previous section.

The **Local current density expression**,  $i_{\text{loc,expr}}$  (SI unit:  $\text{A}/\text{m}^2$ ), can be defined either in the Materials node (**From material**), by using the **From kinetics expression**, or by using a **User defined** expression.

For all kinetic expressions the **Exchange current density**  $i_0$  (SI unit:  $\text{A}/\text{m}^2$ ) is a measure of the kinetic activity. The exchange current density is typically concentration dependent.

Most kinetic expression types feature the **Limiting current density** option in order to impose an upper limit on the local current density magnitude. The feature can be used to model additional mass transport limitations that are not already included in the local current density expression. For **Limiting current density** enter a value for  $i_{\text{lim}}$  (SI unit:  $\text{A}/\text{m}^2$ ).

The **Linearize concentration dependence for low concentrations** option is used to set a **Concentration linearization limit**  $c_{\text{lim}}$  (SI unit:  $\text{mol}/\text{m}^3$ ) for linearizing the concentration dependence of kinetics for low concentrations, in order to improve convergence for nonunit stoichiometries. Note that this option is available for **Nernst Equation** equilibrium potential and **Butler–Volmer** kinetics with **Mass action law**.

### *Butler–Volmer or Linearized Butler–Volmer*

The Butler–Volmer kinetics expression is the most common way to define electrochemical kinetics. The **Linearized Butler–Volmer** option is valid when the overpotentials of the reactions are small ( $\ll 25$  mV). The linearized version can also be used to troubleshoot a model with convergence problems.

When using the **Nernst Equation** for defining the equilibrium potential (see above), the concentration dependence of the **Exchange current density**  $i_0$  can be defined in a thermodynamically consistent way in accordance with the Nernst equation, in combination with a **Reference exchange current density**  $i_{0,\text{ref}}$  ( $\text{A}/\text{m}^2$ ), which is the exchange current density when  $E_{\text{eq}} = E_{\text{eq,ref}}$ .

The **Mass action law** will define the reaction orders according to the reaction stoichiometry and the law of mass action.

The **Anodic transfer coefficient**,  $\alpha_a$  (dimensionless), and **Cathodic transfer coefficient**,  $\alpha_c$  (dimensionless), parameters will impact how much  $i_{loc}$  will change upon changes in the overpotential. In order to ensure thermodynamic consistency,  $\alpha_c$  cannot be user defined when  $i_0$  is calculated by **Mass action law**. For this case,  $\alpha_c$  is defined automatically, based on the number of participating electrons in the reaction, defined in the stoichiometry section.

#### *Anodic Tafel Equation*

This kinetics expression type neglects the cathodic (negative) term in the Butler–Volmer equation. It is only valid for electrode reactions with high anodic overpotentials ( $\gg 100$  mV).

The **Anodic Tafel slope**,  $A_a$  (SI unit: V), defines the required increase in overpotential to result in a tenfold increase in the current density.

#### *Cathodic Tafel Equation*

This kinetics expression type neglects the anodic (positive) term in the Butler–Volmer equation. It is only valid for electrode reactions with significant cathodic overpotentials ( $\ll -100$  mV).

The **Cathodic Tafel slope**,  $A_c$  (SI unit: V), describes the required decrease in overpotential to result in a tenfold increase in the current density magnitude.  $A_c$  should be a negative value.

### **HEAT OF REACTION**

The **Heat of Reaction** section provides two options: **Temperature derivative** and **Thermoneutral voltage** to calculate the reversible heat source of the electrode reaction, which in turn can be used for coupling to heat transfer physics.

The **Temperature derivative of equilibrium potential** parameter,  $dE_{eq}/dT$  (SI unit: V/K), can be specified in the case when **Temperature derivative** is selected. Note that the  $dE_{eq}/dT$  parameter value has no impact on the equilibrium potential variable.

The **Thermoneutral voltage** parameter,  $E_{therm}$  (SI unit: V), can be specified in case of **Thermoneutral voltage** selection.

#### *Reaction*

---

This node is available as a child node at the [Highly Conductive Porous Electrode](#) and [Electrode Surface](#) nodes.

Use this node to define a reaction involving the added species. Set the **Reaction Rate** together with the **Stoichiometric Coefficients** for the reacting species.

### *Potential*

---

To make this node available, click the **Show More Options** button (  ) and select **Advanced Physics Options** in the **Show More Options** dialog.

Add the **Potential** node on a boundary to set a fixed potential. This node is typically used to model electrode surfaces or boundaries facing an electrolyte reservoir.

The node sets the potential in the electrolyte,  $\phi_L$ , to be equal to the **Boundary electrolyte potential**,  $\phi_{L, \text{bnd}}$  (SI unit: V).

### *Species Source*

---

This node can be used to specify species sources at a domain. Use this node to define species sources typically stemming from charge transfer, heterogeneous or homogeneous electrolyte reactions, in an **Electrolyte** domain.

### *No Flux*

---

This node is the default boundary condition on exterior boundaries. It represents boundaries where no mass flows in or out of the boundaries. Hence, the total flux and current density are both zero.

### *Flux*

---

This node can be used to specify the inward species flux across a boundary. Use this node to define species fluxes typically stemming from charge transfer and/or Faradaic reactions at an electrode surface adjacent to an **Electrolyte** domain.

Enter a value or expression for the species molar flux,  $N$  (SI unit:  $\text{mol}/(\text{m}^2 \cdot \text{s})$ ). Use a minus sign when specifying a flux directed out of the system.

### *Reservoir*

---

Use this node to specify the species concentrations at a boundary facing an electrolyte reservoir. The electrolyte potential can be defined either from **Insulation** (default) or by a set **Potential** value.

The concentration values on the boundary are constrained by the use of pointwise constraints.



In the case of weak acid, weak base, and ampholyte species, only the total of the dissociated species concentrations is required. If [Complex Species](#) nodes have been added, the complex species concentrations are computed and subtracted from the complex-forming species automatically.

---

### *Inflow*

---

Use this node to specify the species concentrations at an inlet boundary.

The electrolyte potential can be defined either from **Insulation** (default) or by a set **Potential** value.

When the **Convection** checkbox in the **Additional transport mechanisms** section on the physics interface node has been selected, a **Flux (Danckwerts)** option can be used instead of the otherwise always-available **Concentration constraint**.

The **Concentration constraint** constrains the concentration values on the boundary by the use of pointwise constraints. The other option, **Flux (Danckwerts)** can be more stable and fast to solve when high reaction rates are anticipated in the vicinity of the inlet. Oscillations on the solutions can also be avoided in such cases. The latter condition uses a flux boundary condition based on the velocity across the boundary and the concentration values.



In the case of weak acid, weak base, and ampholyte species, the total of the dissociated species concentrations is only required. If [Complex Species](#) nodes have been added, the complex species concentrations are computed and subtracted from the complex-forming species automatically.

---



### *Outflow*

---

This nodes defines a convective outlet featuring no concentration gradients in the normal direction to the boundary. It is only available when the **Convection** checkbox in the **Additional transport mechanisms** section on the physics interface node has been selected.

The electrolyte current density in the normal direction to the boundary is set to zero.

# The Concentrated Electrolyte Transport Interface

The **Concentrated Electrolyte Transport (cet)** () interface, found under the **Electrochemistry** branch () when adding a physics interface, is used to compute the electrolyte potential and concentration distribution for an electrolyte mixture comprising charged (ions) and neutral species. The interface is suitable for modeling electrolytes featuring large concentration gradients of the charge-carrying ions, where at the same time the concentrations of the charge-carrying ions are significant in relation to the total concentration of all species in the electrolyte mixture.

## OVERVIEW

The interface defines the individual transport of electrolyte species using the Onsager–Stefan–Maxwell equations, which account for the binary interactions between all modeled species in the mixture. In the **Species** section (see below), the active species (cations, anions and neutral species) of the electrolyte mixture are defined. A minimum of one cation and one anion needs to be defined. Internally, various matrix operations are then performed in order to render an equation system defining an electrolyte phase potential (default variable name: `cet.phi1`) and  $n - 2$  (where  $n$  is the total number of electrolyte species) neutral electrolyte component fraction (`cet.y_XXX`) dependent variables.

The names (XXX) of the electrolyte component fractions are generated automatically, and are based on the species names and charges. For instance, the species set consisting of the cation Fe (set to charge +2), the anion OH (charge -1) and the neutral species H<sub>2</sub>O, will render the two electrolyte components Fe\_OH\_2 and H<sub>2</sub>O. Note that the main purpose of defining the neutral electrolyte components is to generate an electroneutral base for the dependent variables of the equation system, and the resulting chemical formulas for the neutral salts may have no correspondence to for instance solid salt compounds in nature.

Due to the constraint of local electroneutrality, a system of  $n$  species results in  $n - 1$  electrolyte components. Since it is also assumed all major electrolyte species are included in the formulation, the equation system can be reduced further to include only  $n - 2$  electrolyte component dependent variables.

Throughout the user interface, symbols related to species are generally shown as  $P_i$ , with  $P$  being the parameter or variable name, and  $i$  the species index, whereas symbols related to electrolyte components are shown as  $\tilde{P}_i$ , that is, with a tilde (~) above the parameter/variable symbol, with  $i$  referring to the electrolyte component index.

The interface adds one [Electrolyte](#) node and one [Reference Electrode](#) as default domain nodes. Both nodes are singletons and cannot be removed.

### SETTINGS

The **Label** is the default physics interface name.

The **Name** is used primarily as a scope prefix for variables defined by the physics interface. Refer to such physics interface variables in expressions using the pattern `<name>.<variable_name>`. In order to distinguish between variables belonging to different physics interfaces, the `name` string must be unique. Only letters, numbers, and underscores (\_) are permitted in the **Name** field. The first character must be a letter.

The default **Name** (for the first physics interface in the model) is `cet`.

### DOMAIN SELECTION

If any part of the model geometry should not partake in the electrolyte transport part of the model, remove that part from the selection list.

### SPECIES

Specify the names and molar masses of the species in the **Cations**, **Anions** and **Neutral species** tables. Only letters and numbers are permitted in the **Name** field. For the **Cations** and **Anions** tables, also define the species charges. As described above in the [Overview](#) section, this will result in a set of  $n - 1$  electrolyte components.

The **Electrolyte component from molar-fraction constraint** setting defines which electrolyte component to be eliminated when defining what  $n - 2$  electrolyte component fractions to use as dependent variables.

### CONSISTENT STABILIZATION

To display this section, click the **Show More Options** button (  ) and select **Stabilization** in the **Show More Options** dialog.

**Streamline diffusion** (enabled by default) adds weak terms to the equation system that may improve the quality of results for convection-dominated problems on coarse meshes. When the **Crosswind diffusion** checkbox is selected, additional weak terms that reduce spurious oscillations are added to the transport equations.

## DISCRETIZATION

To display the settings available in this section, click the **Show More Options** button (  ) and select **Advanced Physics Options** in the **Show More Options** dialog.

The same discretization is used for all dependent variables in the interface. **Quadratic** elements are used by default. See [Overview](#) above regarding what dependent variables are solved for, and naming conventions.

The **Compute boundary fluxes** checkbox is activated by default. When this option is checked, the solver computes variables storing accurate boundary fluxes from each boundary into the adjacent domain. If the checkbox is cleared, the boundary flux variables are computed from the dependent variables using extrapolation, which is less accurate in postprocessing results. This setting does however not create extra dependent variables on the boundaries for the fluxes.

The flux variables affected in the interface are:

- `<name>.nI1`, where `<name>` is the name of the interface. This is the normal electrolyte current density.
- `<name>.ntflux_XXX`. This is the normal total flux for each electrolyte component.

Also the **Apply smoothing to boundary fluxes** checkbox is available if the previous checkbox is checked. The smoothing can provide a more well-behaved flux value close to singularities.

For details about the boundary fluxes settings, see [Computing Accurate Fluxes](#) in the *COMSOL Multiphysics Reference Manual*.

Regarding the **Value type when using splitting of complex variables**, see [Splitting Complex-Valued Variables](#) in the *COMSOL Multiphysics Reference Manual*.



- See also [Theory for the Concentrated Electrolyte Transport Interface](#).
- 

## *Electrolyte*

---

The Electrolyte node defines various mixture properties.

In the **Convection** section, the mixture-averaged velocity of the electrolyte mixture is defined. The **Reference-electrode-stoichiometry based** option defines the velocity based on the electrolyte current vector and the stoichiometry of the [Reference Electrode](#) reaction. This option is applicable when computing steady-state current distributions

when all charge-transfer reactions in the cell are the same as for the reference electrode. This option may also serve as a fair approximation in certain time-dependent problems. The **User defined** option can be used to provide an arbitrary velocity expression, for instance velocity variables computed by a **Fluid Flow** interface.

The **Volumetric Equation of State** section defines the interrelations between the total concentration of all species, the density, and the individual electrolyte component fractions. The equation of state may be based either on a **Density** expression, or **Molar volumes**. The density expression is typically composition dependent. Note that the species **Molar mass** settings, defined on the interface top node, are also used when defining the state equations.

The **Chemical Potentials** section defines how composition changes impacts the chemical potentials of the electrolyte components. By default ideal conditions are assumed, implying that unit chemical activity coefficients are used. Enabling **Specify nonideal thermodynamic factors** allows for defining all independent partial derivatives of the thermodynamic factors with respect to the electrolyte components.

When specifying the nonideal factors, the index k in the formula

$$\tilde{\Lambda}_{i,j} = \tilde{v}_i \left( \frac{\partial \ln \tilde{\lambda}_i}{\partial \tilde{y}_j} \right)_{T,p,\tilde{y}_{l \neq j,k}} \quad (3-4)$$

equals the index of the component selected as **Electrolyte component from molar-fraction constraint** on the interface top node.

### *Diffusion Coefficients*

---

Use this node to define the transport properties of the electrolyte mixture. The Maxwell-Stefan diffusivity coefficients define how gradients in the chemical potentials of the species relate to the difference in species fluxes between all binary species pairs in the mixture.

This node is a child node of the [Electrolyte](#) node.

### *Separator*

---

This node is contributing to the [Electrolyte](#) node and can be used to specify a nonunit electrolyte volume fraction, and to alter the bulk diffusivity coefficients defined in the [Diffusion Coefficients](#) node as a result of a lowered electrolyte volume fraction and the topology (tortuosity) of the porous media. The node is typically used to define an inert

separator, but may also be used to define porous electrodes by combining it by one or multiple [Species Sources](#) nodes.

The **Effective diffusivity correction** setting defines a correction factor which is used as a prefactor to the chemical potential gradients when computing the diffusion fluxes on the [Electrolyte](#) node. The correction may be set to either **Bruggeman**, **Tortuosity**, **Effective diffusivity factor**, or **No correction**.

The **Electrolyte volume fraction** setting defines the relative pore volume of electrolyte in the porous matrix. The setting impacts the mass conservation equation used in time-dependent simulations, but also the diffusion correction factor used in the **Bruggeman** and **Tortuosity** options.

### *Initial Values*

---

Use this node to define the initial values of the dependent variables solved for by the physics interface.

For the electrolyte components, the initial values may be specified as either **Concentrations**, **Mass proportions**, **Molar proportions**, or **Electrolyte component fractions**.

### *Species Sources*

---

Use this node to define species sources, typically stemming from charge transfer, heterogeneous or homogeneous electrolyte reactions, in an [Electrolyte](#) domain.

### *Reference Electrode*

---

Use this node to define the stoichiometry of a reference electrode reaction, which in turn defines the electrolyte phase potential dependent variable added by the [Electrolyte](#) node. By defining a reference electrode stoichiometry, the electrolyte phase potential can be directly related to an experimentally measurable voltage.

By convention the stoichiometry is defined for a reduction reaction (with the electron on the left-hand side). Nonzero values should be specified for at least one anion or one cation.

The reference electrode stoichiometry defined on this node is also used when using a **Reference-electrode-stoichiometry based** mass-averaged velocity in the [Electrolyte](#) node, as well as when defining the resulting electrolyte component fluxes when imposing an [Electrolyte Potential](#) boundary condition.

### *No Flux*

---

This node defines a passive/insulating boundary.

### *Flux*

---

Use this node to define species fluxes, typically stemming from charge transfer and/or nonfaradaic reactions at an electrode surface adjacent to an [Electrolyte](#) domain.

### *Inflow*

---

Use this node at an exterior boundary to define the electrolyte mixture of a convective inlet stream. The electrolyte mixture may be defined either by using the same values as defined on an adjacent [Initial Values](#) domain node, or by specifying the **Concentrations** or **Electrolyte component fractions** on this node.

The boundary condition may be defined using either a **Pointwise constraint** or a **Flux (Danckwerts)** condition. The Pointwise constraint condition can sometimes be a more stable option, whereas the Flux (Danckwerts) may render more consistent results when specifying an upstream mixture composition when there are concentration gradients present in the electrolyte close to the boundary.

The electrolyte current density in the normal direction to boundary is set to zero.

### *Outflow*

---

This node defines a convective outlet featuring no concentration gradients in the normal direction to the boundary.

The electrolyte current density in the normal direction to boundary is set to zero.



### *Electrolyte Potential*

---

Use this boundary node to define an electrode surface operating at a fixed potential in the absence of kinetic activation losses.

The reaction stoichiometry of the electrode reaction is taken from the [Reference Electrode](#) node, and the species fluxes in the normal direction of the boundary will balance the electrolyte current density accordingly.

# The Electrode, Shell Interface

The **Electrode, Shell (els)** interface () , found under the **Electrochemistry** branch () when adding a physics interface, models electric current conduction in the tangential direction on a boundary.

The physics interface is suitable for modeling thin electrodes where the potential variation in the normal direction to the electrode is negligible. This assumption allows for the thin electrode domain to be replaced by a partial differential equation formulation on the boundary. In this way the problem size can be reduced, and potential problems with mesh anisotropy in the thin layer can be avoided.

Ohm's law is used in combination with a charge balance to describe the conduction of currents in the shell electrode.

When this physics interface is added, these default nodes are also added to the **Model Builder** — **Electrode, Electric Insulation** (the default edge or point condition), and **Initial Values**. Then, from the **Physics** toolbar, add other nodes that implement, for example, edge or point conditions and current sources. You can also right-click **Electrode, Shell** to select physics features from the context menu.

## SETTINGS

The **Label** is the default physics interface name.

The **Name** is used primarily as a scope prefix for variables defined by the physics interface. Refer to such physics interface variables in expressions using the pattern `<name>.<variable_name>`. In order to distinguish between variables belonging to different physics interfaces, the `name` string must be unique. Only letters, numbers, and underscores (`_`) are permitted in the **Name** field. The first character must be a letter.

The default **Name** (for the first physics interface in the model) is `els`.

## THICKNESS



For 2D components, enter a value or expression for the **Out-of-plane thickness**  $d$  (SI unit: m). The default value is 1 m.

## DEPENDENT VARIABLES

The dependent variable (field variable) is for the **Electric potential**. The name can be changed but the names of fields and dependent variables must be unique within a model.

## DISCRETIZATION

To see all settings in this section, click the **Show More Options** button (  ) and select **Advanced Physics Options** in the **Show More Options** dialog.



- [Theory for the Electrode, Shell Interface](#)
- [Boundary, Edge, Point, and Pair Nodes for the Electrode, Shell Interface](#)



In the *COMSOL Multiphysics Reference Manual* see [Table 2-4](#) for links to common sections and [Table 2-5](#) to common feature nodes. You can also search for information: press F1 to open the **Help** window or Ctrl+F1 to open the **Documentation** window.

### *Boundary, Edge, Point, and Pair Nodes for the Electrode, Shell Interface*

The [Electrode, Shell Interface](#) has these boundary, edge, point, and pair nodes, listed in alphabetical order, available from the **Physics** ribbon toolbar (Windows users), **Physics** context menu (Mac or Linux users), or right-click to access the context menu (all users).



In general, to add a node, go to the **Physics** toolbar, no matter what operating system you are using. Subnodes are available by clicking the parent node and selecting it from the **Attributes** menu.

These physics nodes are described in this section:

- [Boundary Current Source](#)
- [Current Source](#)
- [Electrode](#)
- [Electric Insulation](#)
- [Electric Potential](#)
- [External Current Density](#)
- [Ground](#)
- [Initial Values](#)
- [Normal Current Density](#)

These nodes are available and described for the Current Distribution interfaces, where edges (3D components) or points (2D and 2D axisymmetric components) are selected instead of boundaries.

- [Electrode Potential](#)
- [Electric Reference Potential](#)



For axisymmetric components, COMSOL Multiphysics takes the axial symmetry boundaries (at  $r = 0$ ) into account and automatically adds an **Axial Symmetry** node to the component that is valid on the axial symmetry boundaries only.

---



In the *COMSOL Multiphysics Reference Manual* see [Table 2-4](#) for links to common sections and [Table 2-5](#) to common feature nodes. You can also search for information: press F1 to open the **Help** window or Ctrl+F1 to open the **Documentation** window.

---

## *Electrode*

---

The **Electrode** node defines the current conduction in the tangential plane. Use the node to define the electrode thickness and electric conductivity.

### **ELECTRODE**

The **Electrode thickness**  $s$  (SI unit: m) defaults to  $10^{-14}$  m.

The default **Electric conductivity**  $\sigma$  (SI unit: S/m) uses values **From material**. Or select **User defined**. For **User defined** enter values or expressions for an isotropic or anisotropic conductivity. Select **Isotropic**, **Diagonal**, **Symmetric**, or **Full** depending on the properties

of the electrolyte. To use another type of temperature dependence than a linear temperature relation, enter any expression for the conductivity as a function of temperature. Then enter a value or expression in the field or matrix.



### *Initial Values*

---

The **Initial Values** node adds the electric potential that can serve as an initial guess for a nonlinear solver. If more than one initial value is needed, add **Initial Values** nodes from the **Physics** toolbar.

#### **INITIAL VALUES**

Enter values or expressions for the **Electric potential** (SI unit: V). The default value is 0 V.

### *External Current Density*

---

Use the **External Current Density** node to define the external current density.

#### **EXTERNAL CURRENT DENSITY**

Based on space dimension, enter the vector components (**x**, **y**, and **z** for 3D components, **x** and **y** for 2D, or **r** and **z** for 2D axisymmetric components) of the **External current density**  $\mathbf{i}_e$  (SI unit: A/m<sup>2</sup>). The defaults are 0 A/m<sup>2</sup>.

### *Current Source*

---

The **Current Source** node adds a source term to [Equation 3-78](#). Use this node to define the current source.

#### **ELECTRODE CURRENT SOURCE**

Enter a value or expression for the **Current source**  $Q_i$  (SI unit: A/m<sup>3</sup>). The default is 0 A/m<sup>3</sup>.

### *Normal Current Density*

---

The **Normal Current Density** node is applicable to exterior boundaries that represent either a source or a sink of current. It sets a condition for the current density according to:

$$\nabla_T \cdot \mathbf{i}_s = i_n$$

The node can be used to couple the Electrode, Shell interface to the electrode reactions in an Electrochemistry interface that describes the electrolyte currents in the adjacent domain.

#### **NORMAL CURRENT DENSITY**

Enter a value for the **Electrode current source**  $i_n$  (SI unit: A/m<sup>2</sup>). The default is 0 A/m<sup>2</sup>.

### *Electric Insulation*

---

The **Electric Insulation** node is the default edge (3D components) and point (2D and 2D axisymmetric components) condition and describes the edges of the shell (boundary) that do not conduct electricity.

### *Boundary Current Source*

---

The **Boundary Current Source** node is available on edges (3D components) and points (2D and 2D axisymmetric components) and sets a condition for the current density according to:

$$\mathbf{i}_s \cdot \mathbf{n} = i_{s,0}$$

#### **BOUNDARY CURRENT SOURCE**

Enter a value or expression for the **Inward current density**  $i_{s,0}$  (SI unit: A/m<sup>2</sup>). The default is 0 A/m<sup>2</sup>.

### *Ground*

---

The **Ground** node is available on edges (3D components) and points (all components) and sets the potential according to  $\phi_s = 0$ .

## EDGE OR POINT SELECTION

---



Beware that constraining the potential on edges or points in 3D or on points in 2D usually yields a current outflow that is mesh dependent.

---

### CONSTRAINT SETTINGS

To display this section, click the **Show More Options** button (  ) and select **Advanced Physics Options** in the **Show More Options** dialog.

### *Electric Potential*

---

The **Electric Potential** node is available on edges (3D components) and points (all components) and sets the potential according to  $\phi_s = \phi_{s,0}$ .

## EDGE OR POINT SELECTION

---



Beware that constraining the potential on edges or points in 3D or on points in 2D usually yields a current outflow that is mesh dependent.

---



### ELECTRIC POTENTIAL

Enter the value or expression for the **Electric potential**  $\phi_{s,0}$  (SI unit: V).

### CONSTRAINT SETTINGS

To display this section, click the **Show More Options** button (  ) and select **Advanced Physics Options** in the **Show More Options** dialog.

# The Electroanalysis Model Wizard Entry

The **Electroanalysis (tcd)** () Model Wizard entry, found under the **Electrochemistry** branch () adds a **Tertiary Current Distribution, Nernst–Planck interface** to the model with the **Electrolyte Charge Conservation Model** set to **Electroanalysis** by default.

The Electroanalysis option is suitable for modeling mass transport of diluted species in electrolytes using the diffusion-convection equation, solving for electroactive species concentrations.

The [Tertiary Current Distribution, Nernst–Planck Interface](#) also features options for modeling cyclic voltammetry and electrochemical impedance spectroscopy.

Use this Model Wizard entry to model electroanalytical problems with electrolyte solutions containing a large quantity of inert “supporting” electrolyte. Ohmic loss is assumed to be negligible.

The Model Wizard entry is available in 1D, 2D, and 3D as well as for axisymmetric components in 1D and 2D.

The default dependent variables are the molar concentrations,  $c_1$  and  $c_2$ , of the two electroactive species in a redox couple and the electric potential,  $\phi_{is}$ , which is solved for either in the Electrode or Porous Electrode domain feature.



- [The Tertiary Current Distribution, Nernst–Planck Interface](#)
  - [Introduction to Electrochemistry Modeling](#)
  - [Theory for Electroanalysis](#)
-

# Theory for the Current Distribution Interfaces

In this section:

- [The Nernst–Planck Equations](#)
- [Domain Equations for Primary and Secondary Current Distributions](#)
- [Electrochemical Reactions and the Difference Between a Primary and a Secondary Current Distribution](#)
- [Domain Equations for Tertiary Current Distributions Using the Nernst–Planck Equations and Electroneutrality](#)
- [Mass Fluxes and Sources Due to Electrochemical Reactions](#)
- [Deposition–Dissolution Rates, Growth Velocities, and Thicknesses on an Electrode Surface](#)
- [Stoichiometric Coefficients for Double Layer Capacitive Charging](#)
- [Film Resistance](#)
- [Equilibrium Potentials and the Nernst Equation](#)
- [Electrode Kinetics Expressions](#)
- [Theory for Specific Current Distribution Feature Nodes](#)
- [Reference](#)



This theory is also relevant to the Current Distribution on Edges, BEM interface. However, due to the use of BEM, current source terms in the electrolyte and porous electrodes cannot be used in this interface.

---

## *The Nernst–Planck Equations*

---

The general mass balance for the diluted species in an electrolyte is described by the following equations for each species  $i$ :

$$\frac{\partial c_i}{\partial t} + \nabla \cdot \mathbf{N}_i = R_{i, \text{tot}}$$

where  $\mathbf{N}_i$  is the total flux of species  $i$  (SI unit: mol/(m<sup>2</sup>·s)). The flux in an electrolyte is described by the Nernst–Planck equations and accounts for the flux of charged solute species (ions) by diffusion, migration, and convection; these are, respectively, the first, second, and third term on the right side in the equation

$$\mathbf{N}_i = -D_i \nabla c_i - z_i u_{m,i} F c_i \nabla \phi_l + c_i \mathbf{u} = \mathbf{J}_i + c_i \mathbf{u}$$

where

- $c_i$  represents the concentration of the ion  $i$  (SI unit: mol/m<sup>3</sup>),
- $z_i$  its valence,
- $D_i$  the diffusion coefficient (SI unit: m<sup>2</sup>/s),
- $u_{m,i}$  its mobility (SI unit: s·mol/kg),
- $F$  denotes the Faraday constant (SI unit: C/mol),
- $\phi_l$  the electrolyte potential,
- $\mathbf{u}$  is, the velocity vector (SI unit: m/s), and
- $\mathbf{J}_i$  denotes the molar flux relative to the convective transport.

$$\mathbf{J}_i = -D_i \nabla c_i - z_i u_{m,i} F c_i \nabla \phi_l$$

The net current density can be described using the sum of all species fluxes:

$$\mathbf{i}_l = F \sum z_i \mathbf{N}_i$$

where  $\mathbf{i}_l$  denotes the current density vector (SI unit: A/m<sup>2</sup>) in the electrolyte.

The Nernst–Planck Equations can be written in nonconservative or conservative form. The nonconservative formulations are applicable to systems that contain incompressible electrolytes. For these electrolytes, the following continuity equation is satisfied:

$$\nabla \cdot \mathbf{u} = 0$$

The velocity vector in the convective term can therefore be moved out of the divergence operator which gives the nonconservative form of the Nernst–Planck equations:

$$\frac{\partial c_i}{\partial t} + \nabla \cdot \mathbf{J}_i + \mathbf{u} \cdot \nabla c_i = R_i$$

On the other hand, for compressible electrolytes, the convective term cannot be simplified and the use of the following conservative form of the Nernst–Planck equations is applicable:

$$\frac{\partial c_i}{\partial t} + \nabla \cdot (\mathbf{J}_i + c_i \mathbf{u}) = R_i$$

For mass transport in porous systems, the accumulation term differs between the conservative and nonconservative formulations. The electrolyte volume fraction (the porosity),  $\varepsilon_i$ , is differentiated in the conservative form giving the following formulation:

$$\frac{\partial(\varepsilon_i c_i)}{\partial t} + \nabla \cdot (\mathbf{J}_i + c_i \mathbf{u}) = R_i$$

In contrast, for the nonconservative case  $\varepsilon_i$  is not differentiated:

$$\varepsilon_i \frac{\partial c_i}{\partial t} + \nabla \cdot \mathbf{J}_i + \mathbf{u} \cdot \nabla c_i = R_i$$

Considering a system with no producing or consuming species reactions, these formulations ensure constant species concentration (mass conservation) over the model domains together with accumulated mass across in/outflow boundaries over time.

### *Domain Equations for Primary and Secondary Current Distributions*

---

Assuming electroneutrality (which cancels out the convection term) and negligible concentration gradients of the current-carrying ion (which cancels out the diffusion term), the following expression is left for the current density vector in an electrolyte:

$$\mathbf{i}_l = -F^2 \sum z_i^2 u_{m,i} c_i \nabla \phi_l.$$

Further, assuming an approximately constant composition of charge carriers, a constant electrolyte conductivity can be defined as

$$\sigma_l = F^2 \sum z_i^2 u_{m,i} c_i$$

so the current density in the electrolyte can be written as

$$\mathbf{i}_l = -\sigma_l \nabla \phi_l$$

This equation takes the same form as Ohm's law; in an electrolyte, charge transport is ohmic, subject to the above assumptions.

Conservation of charge yields the domain equation usually used for the electrolyte in the Primary and Secondary Current Distribution interfaces:

$$\nabla \cdot \mathbf{i}_l = 0$$



In a pore electrolyte, the homogenization used in the theory for porous electrodes introduces a source or sink term in the pore electrolyte current balances due to the charge transfer reactions at the electrode-electrolyte interface within the porous material. In such cases, a source term,  $Q_l$ , is introduced on the right-hand side of the equation above.

The Primary and Secondary Current Distribution interfaces define two dependent variables: one for the potential in the electrolyte and one for the electric potential in the electrode. The conduction of current in the electrolyte is assumed to take place through transport of ions as described above, while electrons conduct the current in the electrode.

Since Ohm's law is also used for current conduction in the solid electrode phase, the general equation in these interfaces is according to

$$\nabla \cdot \mathbf{i}_k = Q_k$$

with

$$\mathbf{i}_k = -\sigma_k \nabla \phi_k$$

where  $Q_k$  denotes a general source term,  $k$  denotes an index that is  $l$  for the *electrolyte* or  $s$  for the *electrode*,  $\sigma_k$  denotes the conductivity (SI unit: S/m) and  $\phi_k$  the potential (SI unit: V).

### *Electrochemical Reactions and the Difference Between a Primary and a Secondary Current Distribution*

Both the primary and secondary current distribution models assume an electrolyte that conducts current according to Ohm's law, with a constant conductivity. The difference between a primary and a secondary current distribution lies in the description of the

electrochemical *charge transfer reaction* at the interface between an electrolyte and an electrode. The charge transfer reactions can be defined as boundary conditions, or as sources or sinks in a domain for the case of *porous electrodes*.

The rate of the electrochemical reactions can be described by relating the reaction rate to the activation *overpotential*. For an electrode reaction, with index  $m$ , the activation overpotential, denoted  $\eta_m$ , is

$$\eta_m = \phi_s - \phi_l - E_{\text{eq},m}$$

where  $E_{\text{eq},m}$  denotes the *equilibrium potential* (also known as a reduction potential) for reaction  $m$ .

In the Primary Current Distribution interface, the electrochemical reactions are assumed to be fast enough that their kinetics have negligible influence on the cell voltage. Consequently, the activation overpotential,  $\eta_m$ , in this physics interface is equal to zero, and the difference in potential between the electrode and the electrolyte is always equal to the equilibrium potential,  $E_{\text{eq},m}$ . This condition is implemented as the following constraint on boundaries between electrodes and electrolyte domains:

$$\phi_l = \phi_s - E_{\text{eq},m}$$



A good modeling practice is to estimate the influence of finite reaction kinetics on the cell voltage and to compare the associated activation losses to the ohmic losses in a cell to check the validity of the primary current distribution assumption.

---

In the Secondary Current Distribution interface, the electrochemical reactions are described as a function of the overpotential. The physics interface uses several relations for the charge transfer current density and the overpotential, such as Butler–Volmer and Tafel expressions. The most general expression is of Butler–Volmer type:

$$i_{\text{loc},m} = i_{0,m} \left( \exp\left(\frac{\alpha_{a,m} F \eta_m}{RT}\right) - \exp\left(\frac{-\alpha_{c,m} F \eta_m}{RT}\right) \right)$$

where  $i_{loc,m}$  denotes the local charge transfer current density for reaction  $m$ ,  $i_{0,m}$  the exchange current density,  $\alpha_{a,m}$  the anodic transfer coefficient,  $\alpha_{c,m}$  the cathodic charge transfer coefficient,  $F$  Faraday's constant, and  $R$  the universal gas constant.



Both the exchange current density and the overpotential are typically concentration dependent. It is possible to include the dependence of kinetics on concentration in the expression above. It is also possible to use other kinetics expressions.

See [Equilibrium Potentials and the Nernst Equation](#) and [Electrode Kinetics Expressions](#).

The sum of all electrode reaction currents is implemented as a current density condition on the boundary between an electrode and an electrolyte domain according to

$$\mathbf{i}_l \cdot \mathbf{n} = \sum_m i_{loc,m}$$

$$\mathbf{i}_s \cdot \mathbf{n} = -\sum_m i_{loc,m}$$

Both the Primary Current Distribution and Secondary Current Density Distribution interfaces allow for a domain definition for porous electrodes. For the Primary Current Distribution interface, the same constraint as above is applied.

In porous electrodes for the Secondary Current Distribution interface, the sum of all reaction currents appears as a source in the domain equations:

$$\nabla \cdot \mathbf{i}_l = \sum_m A_{v,m} i_{loc,m}$$

$$\nabla \cdot \mathbf{i}_s = -\sum_m A_{v,m} i_{loc,m}$$

where  $A_{v,m}$  is the surface area.



The only reason to add Porous Electrode descriptions to the Primary Current Distribution interface is to be able to expand a model to include charge transfer resistance.

## Domain Equations for Tertiary Current Distributions Using the Nernst–Planck Equations and Electroneutrality

---

The domain equations can be derived by starting with [The Nernst–Planck Equations](#). The material balance equation for each species  $i$  in the electrolyte is given by the continuity equation, with a flux given by the Nernst–Planck equation:

$$\frac{\partial c_i}{\partial t} + \nabla \cdot (\mathbf{J}_i + c_i \mathbf{u}) = R_{i, \text{tot}}$$

where

- $c_i$  denotes the concentration of species  $i$  (SI unit: mol/m<sup>3</sup>),
- $\mathbf{u}$  is, the velocity vector (SI unit: m/s), and
- $\mathbf{J}_i$  denotes the molar flux relative to the convective transport (see [Equation](#) )

The material balances give one equation per unknown species concentration.



The concentration gradients are not assumed to be negligible here, and so the contribution of ion diffusion to overall current density can be nonzero. (Compare with the [Domain Equations for Primary and Secondary Current Distributions](#).)

---

There is one more unknown dependent in the variable, the *electrolyte potential*, which requires an additional equation to close the system. This equation is the electroneutrality condition, which follows from dimensional analysis of Gauss’s law. In a typical electrolyte solution, it is accurate over lengths greater than a few nanometers:

$$\sum z_i c_i = 0$$

Using the electroneutrality condition reduces the number of dependent concentration variables by one.

Further, by combining the electroneutrality condition with the sum of all species flux vectors and the species mass balance equation, multiplied by the individual species charges, results in expressions for the current vector and a current balance equation, respectively.

The expression for the current density in the electrolyte,  $\mathbf{i}_l$ , reads

$$\mathbf{i}_l = F \sum_{i=1}^n z_i (-D_i \nabla c_i - z_i u_{m,i} F c_i \nabla \phi_l) = F \sum_{i=1}^n z_i \mathbf{J}_i$$

whereas current balance in the electrolyte, used for solving for the electrolyte potential, then becomes

$$\nabla \cdot \mathbf{i}_l = Q_l$$

where  $Q_l$  can be any source or sink. ( $Q_l$  is typically nonzero for porous electrodes). These formulations are also valid for the pore electrolyte in porous electrodes, except for the transport properties that have to be corrected for porosity and tortuosity. In such cases, the source or sink,  $Q_l$ , denotes the charge transfer reactions in the porous electrode and/or the nonfaradaic source or sink due to double layer charge and discharge.

The charge transfer reaction can be parameterized by arbitrary functions of the concentrations of the species in the redox couple and the local electric and electrolyte potentials. The most common way to describe the reaction kinetics is to use a Butler–Volmer expression for the charge transfer current density. See [The Butler–Volmer Equation](#).

In the current balance in a porous electrode, the local current density multiplied by the specific surface area of an electrode gives a contribution to the source or sink,  $Q_l$ , due to electrochemical reactions.

### *Mass Fluxes and Sources Due to Electrochemical Reactions*

---

When relating the species fluxes at an electrode surface to the electric currents, the general electrochemical reaction formula

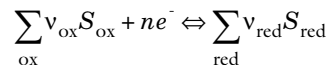

is used to define the stoichiometric coefficients,  $\nu_i$ , with  $\nu_i$  being positive ( $\nu_{\text{red}}$ ) for products and negative ( $\nu_{\text{ox}}$ ) for the reactants in a reduction reaction. The number of participating electrons,  $n$ , is always positive.

The molar species fluxes,  $N_i$  (SI unit: mol/(m<sup>2</sup>·s)), perpendicular to an electrode–electrolyte interface are calculated by summing all the flux contributions from the electrode reactions of index  $m$ , according to Faraday’s laws:

$$N_i = \sum_m \frac{v_{i,m} i_{loc,m}}{n_m F}$$

where  $i_{loc,m}$  is the local current density (SI unit: A/m<sup>2</sup>) of the electrochemical reaction,  $n_m$  the number of participating electrons and  $F$  (SI unit: C/mol) is the *Faraday constant*. Note that  $i_{loc,m}$  denotes the current density perpendicular to the electrode surface.

The molar species flux,  $N_i$ , is obtained from the normal component of the molar species flux vector over the electrode–electrolyte interface:

$$N_i = \mathbf{N}_i \cdot \mathbf{n}$$

where  $\mathbf{n}$  is the normal vector of the boundary pointing into the domain.

For a porous electrode, the electrochemical reactions result in species source terms calculated from

$$R_{i, \text{molar}} = -\sum_m a_{v,m} \frac{v_{i,m} i_{loc,m}}{n_m F}$$

where  $a_{v,m}$  (SI unit: m<sup>2</sup>/m<sup>3</sup>) is the specific surface area.

### *Deposition–Dissolution Rates, Growth Velocities, and Thicknesses on an Electrode Surface*

---

The rate of dissolution or deposition on due to an electrode reaction is defined based on the reaction stoichiometry,  $v_{i,m}$ , and the local current density,  $i_{loc,m}$ , as described in [Mass Fluxes and Sources Due to Electrochemical Reactions](#).

If the reaction rate is known, the total growth  $v_{\text{dep, tot}}$  (m/s) is defined as the sum of the velocity contributions for all species and electrode reactions according to:

$$v_{\text{dep, tot}} = -\sum_i \frac{M_i}{\rho_i} \sum_m \frac{v_{i,m} i_{loc,m}}{n_m F} \quad (3-5)$$

Where  $M_i$  (SI unit: kg/mol) is the molar mass and  $\rho_i$  (SI unit: kg/m<sup>3</sup>) the density of the species. ( $i$  is the species index, and  $m$  the index of the electrode reaction).

This velocity can be used in deforming geometry models as a boundary condition for the geometry deformation by assuming that dissolution or deposition always occurs in

the normal direction to an electrode boundary, with the velocity being directed into the electrolyte domain:

$$\frac{\partial \mathbf{x}}{\partial t} \cdot \mathbf{n} = v_{\text{dep, tot}}$$

In a time-dependent simulation one may also introduce a surface concentration variable,  $c_{s,i}$  (mol/m<sup>2</sup>) on the boundary and calculate the accumulated surface concentration change by using a local ordinary differential equation (ODE):

$$\frac{dc_{s,i}}{dt} = -\sum_m \frac{v_{i,m} i_{\text{loc},m}}{n_m F}$$

The total deposited thickness  $s_{\text{tot}}$ (m) can then be defined as

$$s_{\text{tot}} = \sum_i \frac{M_i}{\rho_i} c_{s,i}$$

### *Stoichiometric Coefficients for Double Layer Capacitive Charging*

---

A negative capacitive current corresponds to the accumulation of negative charge on the electrode surface, and a corresponding counterbalanced positive charge accumulating in the double layer. This can be understood in terms of conservation of current: cathodic capacitive current at the electrode corresponds to the overall injection of negative charge (from the double layer) into the electrolyte, just as a cathodic Faradaic current would add negative charge to the electrolyte through electron transfer.

Consider an overall reaction as:

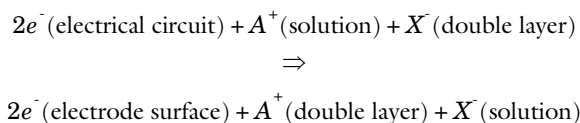

This corresponds to a negative charge of  $2F$  being moved from double layer to solution. Following the convention that the reaction is written in the order of cathodic current (as above), then with respect to the free solution species, the cation is a reactant (negative stoichiometry) and the anion is a product (positive stoichiometry). This suggests  $\nu_A = -1$ ,  $\nu_X = +1$ , and  $n = 2$  for an ideal double layer where both anion and cation have similar contributions to the double layer charge.

## Film Resistance

---

If a resistive film forms on the interface between an electrode and an electrolyte, this results in additional potential losses. To model a film resistance, an extra dependent variable for the potential drop over the film,  $\Delta\phi_{s, \text{film}}$ , is introduced. The governing equation is:

$$\Delta\phi_{s, \text{film}} = i_{\text{tot}} R_{\text{film}}$$

Where  $R_{\text{film}}$  (SI unit: ohm·m<sup>2</sup>) is a generalized film resistance and  $i_{\text{tot}}$  the sum of all currents over the interface. The activation overpotentials,  $\eta_m$ , for all occurring electrode reactions on the electrode with the film receive an extra potential contribution due to the film resistance according to:

$$\eta_m = \phi_s - \Delta\phi_{s, \text{film}} - \phi_l - E_{0, m}$$

If the thickness and conductivity of the film are known, the resistance can be written as:

$$R_{\text{film}} = \frac{s_0 + \Delta s}{\sigma_{\text{film}}}$$

where  $s_0$  is the reference/initial film thickness,  $\Delta s$  the electrode thickness change, and  $\sigma_{\text{film}}$  the conductivity (SI unit: S/m) of the film.

## Equilibrium Potentials and the Nernst Equation

---

Consider an arbitrary, possibly multielectron step, redox reaction involving a number of species  $S_i$  defined as

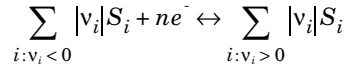

where  $v_i$  is the stoichiometric coefficient of the reacting species of index  $i$  and  $n$  is the number of participating electrons.

The equilibrium potential of the electrode reaction,  $E_{\text{eq}}$  (V), is the electrode potential (the difference between the electrode phase and electrolyte phase potentials,  $\phi_s - \phi_l$ ) for which the net reaction rate (and the local current density,  $i_{\text{loc}}$ ) is zero.

The equilibrium potential is directly related to the change of Gibbs free energy of the reacting species,  $\Delta G$ , as

$$E_{\text{eq}} = -\frac{\Delta G}{nF}$$

Since the free energy of the reacting species is concentration dependent, also the equilibrium potential is concentration (activity) dependent.  $E_{\text{eq}}$  is usually defined according to the Nernst equation as

$$E_{\text{eq}} = E_{\text{eq,ref}} - \frac{RT}{nF} \ln \prod_i \left( \frac{a_i}{a_{i,\text{ref}}} \right)^{\nu_i}$$

where  $E_{\text{eq,ref}}$  (V) is the equilibrium potential for a reference state for which all species activities  $a_i$  (unitless) are equal to a chosen set of reference activities  $a_{i,\text{ref}}$  (unitless).

For ideal solutions, the activities are replaced by concentrations. Standard conditions correspond to reference concentrations of 1M for soluble species in the electrolyte, partial pressures of 1 atm for gaseous species. Constant activities of 1 is used for solid (metal) species and solvents.

### *Electrode Kinetics Expressions*

---

A number of different analytical expressions for the current density perpendicular to the electrode surface,  $i_{\text{loc},m}$ , are available. In the following paragraphs, the index  $m$  is dropped. All parameters are understood to refer to a specific reaction.

#### **THE EQUILIBRIUM POTENTIAL AND THE OVERPOTENTIAL**

The rate of the electrochemical reactions can be described by relating the reaction rate to the activation overpotential. For an electrode reaction, the activation overpotential, denoted  $\eta$  (V), is the following:

$$\eta = \phi_s - \phi_l - E_{\text{eq}}$$

where  $E_{\text{eq}}$  denotes the equilibrium potential.

#### **THE BUTLER-VOLMER EQUATION**

A common expression for the current density as a function of the activation overpotential, in modeling of electrochemical systems, is the Butler-Volmer equation:

$$i_{\text{loc}} = i_0 \left( \exp\left(\frac{\alpha_a F \eta}{RT}\right) - \exp\left(\frac{-\alpha_c F \eta}{RT}\right) \right)$$

where  $\alpha_c$  (unitless) denotes the cathodic charge transfer coefficient,  $\alpha_a$  (unitless) the anodic charge transfer coefficient, and  $i_0$  (SI unit: A/m<sup>2</sup>) is the exchange current density.

It should be noted that, although used extensively for all sorts of reactions in the electrochemical community, the Butler–Volmer equation was originally derived for single-electron transfer reactions (for instance implying that the reaction does not involve the breaking or creation of a chemical bond).

#### *Concentration Dependence and the Exchange Current Density*

The exchange current density is generally concentration dependent. For certain conditions, it is possible to derive analytical expressions for  $i_0$ . Assuming a concentration dependent equilibrium potential defined by the Nernst equation (see previous section [Equilibrium Potentials and the Nernst Equation](#)), the kinetics to follow the law of mass action, and the condition that  $\alpha_a + \alpha_c = n$ , then the exchange current density becomes

$$i_0 = i_{0,\text{ref}} \prod_{i:v_i > 0} \left( \frac{a_i}{a_{i,\text{ref}}} \right)^{\frac{\alpha_c v_i}{n}} \prod_{i:v_i < 0} \left( \frac{a_i}{a_{i,\text{ref}}} \right)^{\frac{-\alpha_a v_i}{n}}$$

where  $i_{0,\text{ref}}$  is the exchange current density (SI unit: A/m<sup>2</sup>) at the reference state. The above expression can be derived from the mass action law, which gives the following expression for the local current density:

$$i_{\text{loc}} = i_{0,\text{ref}} \left( \prod_{i:v_i > 0} \left( \frac{a_i}{a_{i,\text{ref}}} \right)^{v_i} \exp\left(\frac{\alpha_a F \eta_{\text{ref}}}{RT}\right) - \prod_{i:v_i < 0} \left( \frac{a_i}{a_{i,\text{ref}}} \right)^{-v_i} \exp\left(\frac{-\alpha_c F \eta_{\text{ref}}}{RT}\right) \right)$$

where the overpotential  $\eta_{\text{ref}}$  (SI unit: V) is measured using relative to a reference state, which yields:

$$\eta_{\text{ref}} = \phi_s - \phi_l - E_{\text{eq,ref}}.$$

This latter form of the Butler–Volmer equation, where the reference overpotential and the exchange current density do not vary with concentration, is usually preferable numerically.

The law of mass action is usually not suitable for defining complex reactions involving multiple electron steps. For certain multi-electron reactions, where one electron transfer step is rate limiting, it is possible to derive a lumped Butler–Volmer expressions using the following relation for the exchange current density (see [Ref. 1](#)):

$$i_0 = i_{0,\text{ref}} \prod_i \left( \frac{a_i}{a_{i,\text{ref}}} \right)^{\gamma_i}$$

where  $\gamma_i$  are generic exponential coefficients. For this case,  $\alpha_a$  and  $\alpha_c$  may be independently defined. By rearranging the Butler–Volmer expression using  $\eta_{\text{ref}}$  similarly to what was done for the mass action law case above, the  $\gamma_i$  coefficients relate to the anodic,  $\xi_{a,i}$ , or cathodic,  $\xi_{c,i}$ , reaction orders according to

$$\xi_{a,i} = \gamma_i + \frac{\alpha_a \nu_i}{n}$$

and

$$\xi_{c,i} = \gamma_i - \frac{\alpha_c \nu_i}{n}.$$

#### *Exchange Current Density and Rate Constants*

In electroanalysis, one commonly defines electrode kinetics in terms of rate constants rather than exchange current densities.

For instance, for a one electron redox couple of concentrations  $c_o$  and  $c_r$ , with the same reference concentration  $c_{\text{ref}}$  for both species, and  $i_{0,\text{ref}} = k_0 F c_{\text{ref}}$ , the mass action law expression above can be rewritten as

$$i_{\text{loc}} = k_0 F \left( c_r \exp\left(\frac{\alpha_a F \eta}{RT}\right) - c_o \exp\left(\frac{-\alpha_c F \eta}{RT}\right) \right)$$

where  $k_0$  (m/s) is the heterogeneous rate constant.

#### *Generic Concentration-Dependent Butler–Volmer Type Kinetics*

This expression type gives more freedom for the user to define concentration dependent Butler–Volmer types of expressions, where the anodic and cathodic terms of the current density expression, typically depending on the local concentrations of the electroactive species at the electrode surface, can be individually defined:

$$i_{\text{loc}} = i_0 \left( C_R \exp\left(\frac{\alpha_a F \eta}{RT}\right) - C_O \exp\left(\frac{-\alpha_c F \eta}{RT}\right) \right)$$

Here,  $C_R$  and  $C_O$  are dimensionless expressions, describing the dependence on the reduced and oxidized species in the reaction. Note that if  $C_O \neq C_R$  when  $\eta = 0$ , this kinetics expression results in  $i_{\text{loc}} \neq 0$ , thus violating the concept of equilibrium. This

may result in thermodynamical inconsistencies, for instance when coupling an electrochemical model to heat transfer.

## SIMPLIFICATIONS OF THE BUTLER–VOLMER EQUATION

### *Linearized Butler–Volmer*

The charge transfer reaction can be expressed by a linearized Butler–Volmer expression, which can be used for small overpotentials ( $\eta \ll RT/F$ ) and is usually referred to as the low-field approximation. This approximation gives the following linearized equation:

$$i_{\text{loc}} = i_0 \left( \frac{(\alpha_a + \alpha_c)F}{RT} \right) \eta$$

### *Anodic and Cathodic Tafel Equations*

By assuming either high anodic or cathodic overpotentials for a given current (that is, slow kinetics or low  $i_0$ ), one of the terms in the original Butler–Volmer potentials can be neglected.

The anodic Tafel equation is implemented as follows:

$$i_{\text{loc}} = i_0 \cdot 10^{\eta/A_a}$$

where  $A_a$  (SI unit: V) is the so-called Tafel slope.  $A_a$  relates to the corresponding transfer coefficient as

$$A_a = \frac{RT \ln 10}{\alpha_a F}$$

The cathodic Tafel expression is defined according to

$$i_{\text{loc}} = -i_0 \cdot 10^{\eta/A_c}$$

where the sign accounts for the negative cathodic charge transfer current. Here,  $A_c$  is required to be negative and relates to the transfer coefficient according to

$$A_c = -\frac{RT \ln 10}{\alpha_c F}$$

### LIMITING CURRENT DENSITY

The steady-state rate of electrode reactions can never exceed the rate at which reactants and products can be transported to and from the electrode surface. When explicitly including mass transport in a model, this dependence is typically described in concentration dependence of the equilibrium potential and the exchange current density as described above.

When not explicitly including mass transfer in the domain equations one can still include the effect of transport limitations by the assumption of a Nernst diffusion layer at the electrode surface, and a first-order dependence between the charge transfer current and the local concentration of a reacting species, resulting in the following kinetics expression:

$$i_{\text{loc}} = \frac{i_{\text{expr}}}{1 + \left\| \frac{i_{\text{expr}}}{i_{\text{lim}}} \right\|}$$

where  $i_{\text{expr}}$  ( $\text{A}/\text{m}^2$ ) is the current density expression in the absence of mass transport limitations for the species, and  $i_{\text{lim}}$  ( $\text{A}/\text{m}^2$ ) is the limiting current density that corresponds to the maximum transport rate of the species. The derivation of this expression assumes high overpotentials so that either the anodic or a cathodic term in the Butler–Volmer equation may be neglected.

### LINEARIZE CONCENTRATION DEPENDENCE FOR LOW CONCENTRATIONS

Consider a concentration-based kinetic expression

$$\frac{dc}{dt} = r = -kc^{\nu}$$

where  $\nu$  and  $k$  are positive numbers and the desired behavior is that the rate  $r$  and the concentration  $c$  should equal zero in the converged solution at infinite time. However, if  $c$ , due to numerical fluctuations in the solver process, becomes negative during iterating, issues may arise.

First consider the case when  $\nu$  equals 1 (or any odd positive integer). Negative values of  $c$  will then cause the rate to become positive, resulting in a “self-stabilizing” situation where  $c$  will be approaching 0 with time.

A second case to consider is when  $\nu$  is an even integer larger than 1. The rate then will become increasingly negative for negative values of  $c$ , resulting in an “exploding” solution, iterating  $c$  toward minus infinity. The standard solution for these cases, which

also works for noninteger  $\nu$  values larger than 1, is to change the expression  $c$  in the rate term to  $\max(c, \text{eps})$ , where  $\text{eps}$  is a small number. This will avoid the “exploding” behavior, but result in poor convergence rate for negative  $c$  values since the Jacobian of the rate with respect to  $c$  then becomes zero for negative  $c$  values.

The third case is when  $\nu$  is a noninteger between 0 and 1. Note now that Jacobian with respect to  $c$  of the rate expression now contains  $c^{\nu-1}$ , which will approach minus infinity when  $c$  approaches zero from the positive side. This may result in poor convergence, and the  $\max()$  wrapping will not improve convergence in this case.

The solution for the third case is to linearize the concentration dependence for low concentrations; that is, to use

$$r = -kc^\nu \quad c > c_{\text{lim}}$$

$$r = -kcc_{\text{lim}}^{\nu-1} \quad c \leq c_{\text{lim}}$$

which results in the desired convergence behavior for low and negative concentrations. Note, however, that the linearization may result in thermodynamic inconsistencies so that, for instance, relations like the Nernst equation for the equilibrium potential are no longer fulfilled. The linearization may also improve convergence of the second case above.

### *Theory for Specific Current Distribution Feature Nodes*

---

#### **ELECTROLYTE THEORY**

The Electrolyte node defines a current balance in the electrolyte. The domain equation is

$$\nabla \cdot \mathbf{i}_t = 0$$

where  $\mathbf{i}_t$  denotes the current density vector. In free electrolyte, there is no source or sink of charge.

The definition of the current density vector depends on the equation formulation of the electrolyte charge transport, as discussed above in [Domain Equations for Primary](#)



- For the Primary and Secondary Current Distribution interfaces, see [Electrolyte](#).
- For the Tertiary Current Distribution, Nernst–Planck interface, see [Electrolyte](#).

### POROUS ELECTRODE THEORY

A porous electrode is a mixed material with one electrode phase and one electrolyte phase. (A special case of a porous electrode is the gas diffusion electrode, as found in a fuel cell. These contain a gas pore phase which is inert to charge transfer.) To model a porous electrode we define two separate current balances according to the following equations:

$$\nabla \cdot \mathbf{i}_l = Q_l \text{ and } \nabla \cdot \mathbf{i}_s = Q_s$$

In these equations,  $\mathbf{i}_l$  denotes the current density vector in the electrolyte, as discussed above in [Domain Equations for Primary and Secondary Current Distributions](#) and [Domain Equations for Tertiary Current Distributions Using the Nernst–Planck Equations and Electroneutrality](#).

In addition to the current balances, it is necessary to also formulate mass balance equations for the species in the electrolyte phase for the tertiary case.

It is also common to use corrected conductivities and diffusion parameter values in a porous electrode to account for the lowered volume fraction of the conducting phase, and the longer transport distance due to the tortuosity of the pores.

The current balances in the pore electrolyte and in the electrode matrix contain sources and sinks according to the charge transfer reactions that take place in the electrode catalyst. For example, if only one charge transfer reaction takes place in the porous electrode, the domain equations are the following:

$$\begin{aligned}\nabla \cdot \mathbf{i}_l &= A_v i_{loc} \\ \nabla \cdot \mathbf{i}_s &= -A_v i_{loc}\end{aligned}$$

where  $A_v$  denotes the specific surface area (dimension  $L^2/L^3$ ), and  $i_{loc}$  the local current density defines the rate of the charge transfer reactions, for instance according

to the Butler–Volmer equation. For various ways of defining  $i_{loc}$ , see [Electrode Kinetics Expressions](#).

If the porous electrode is a cathode, then the charge transfer reaction is a source for the current balance in the electrode, because it receives current from the pore electrolyte. The charge transfer reaction is then a sink for the current balance in the pore electrolyte, because the current is transferred from the pore electrolyte to the electrode in a cathodic reaction.

The corresponding sources and sinks in the current balances that are due to the charge transfer reactions are also coupled to the material balances for the charged species. This means that the local current density expression above is also included in the material balances as a reaction term,  $R_i$ , by using Faraday’s laws for each of the species that take part in charge transfer reactions.



- For the Primary and Secondary Current Distribution interfaces, see [Porous Electrode](#).
- For the Tertiary Current Distribution, Nernst–Planck interface, see [Porous Electrode](#).

### ELECTRODE REACTIONS THEORY

Charge transfer reactions occurring at an interface between an electrode and an electrolyte domain gives rise to a normal current flux that equals the sum of all reaction currents according to

$$\mathbf{i}_l \cdot \mathbf{n} = \sum_m i_{loc, m}$$

$$\mathbf{i}_s \cdot \mathbf{n} = -\sum_m i_{loc, m}$$

where  $i_{loc, m}$  ( $A/m^2$ ) is the [Electrode Reaction](#) current density of the charge transfer electrode reaction of index  $m$ ,  $\mathbf{i}_l$  the current density vector in the electrolyte and  $\mathbf{i}_s$  the current density vector in the electrode.

### POROUS ELECTRODE REACTIONS THEORY

For a porous electrode, the electrode reaction current densities are multiplied by the surface area to yield a source or sink in the current balance domain equation according to

$$\nabla \cdot \mathbf{i}_l = \sum_m A_v i_{\text{loc}, m}$$

$$\nabla \cdot \mathbf{i}_s = -\sum_m A_v i_{\text{loc}, m}$$

where  $A_v$  is the specific surface area of the electrocatalyst.



## Porous Electrode Reaction

### ELECTRODE THEORY

Electron conduction in an **Current Conductor** is modeled using Ohm's law. The domain equation is the following:

$$\nabla \cdot \mathbf{i}_s = 0$$

where  $\mathbf{i}_s$  denotes the current density vector according to

$$\mathbf{i}_s = -\sigma_s \nabla \phi_s$$

and where  $\sigma_s$  denotes the electric conductivity and  $\phi_s$  the potential of the electron conducting (metal) phase.

### ELECTROLYTE CURRENT DENSITY THEORY

An applied current density can be defined as its component perpendicular to the boundary according to

$$\mathbf{i}_l \cdot \mathbf{n} = i_{n, l}$$

The current density can also be defined including all its components:

$$\mathbf{i}_l = \mathbf{i}_{l, \text{bnd}}$$

where  $\mathbf{i}_{l, \text{bnd}}$  is a given expression for the current density vector.



## Electrolyte Current Density

## ELECTROLYTE CURRENT THEORY

The **Electrode Current** boundary condition sets the total current at a given position in the electrolyte without imposing a current density distribution. The conditions yields a constant electrolyte potential, along the given boundary, that satisfies the total value of the current. The boundary condition is a good choice in the middle of a cell with planar electrodes, where the isopotential level can be a plane (or close to a plane in 3D, or line in 2D) but where the current density distribution is unknown.

The feature adds one unknown variable, the electrolyte potential,  $\phi_{l,\text{bnd}}$ , along the boundary. It then adds one additional equation for the total current, which is an integral over the boundary:

$$\int_{\partial\Omega} \mathbf{i}_l \cdot \mathbf{n} ds = I_{n,l}$$

The average current density condition imposes the same equation but multiplies the current density by the area of the boundary to obtain the value of the total current  $I_{n,l}$ .

## ELECTRODE CURRENT THEORY

The **Electrode Current** adds one unknown variable, the electric potential,  $\phi_{s,\text{bnd}}$ , along the boundary. It then adds one additional equation for the total current, which is an integral over the boundary:

$$\int_{\partial\Omega} \mathbf{i}_s \cdot \mathbf{n} ds = I_{n,s}$$

where

$$\mathbf{i}_s = -\sigma_s \nabla \phi_s$$

and  $\sigma_s$  denotes the electrode conductivity and  $\phi_s$  the electric potential. The average current density condition imposes the same equation but multiplies the current density by the area of the boundary to obtain the value of the total current,  $I_{n,s}$ .

If a contact resistance  $R_c$  is included, the following current density condition is used:

$$-\mathbf{n} \cdot \mathbf{i}_s = \frac{\phi_{s,\text{bnd}} - \phi_s}{R_c}$$

### SYMMETRY THEORY

The **Symmetry** boundary condition, in the Primary Current Distribution and Secondary Current Distribution interfaces is identical to the Insulation condition and is expressed according to the equation

$$\mathbf{i}_k \cdot \mathbf{n} = 0$$

where  $\mathbf{i}_k$  denotes the current density vector and  $k = l, s$  is an index for the electrolyte and electrode, respectively.

The Symmetry boundary condition for the Tertiary Current Distribution, Nernst–Planck interface imposes a no-flux condition for the molar flux of species at a boundary. The condition is expressed as

$$\mathbf{J}_i \cdot \mathbf{n} = 0$$

### ELECTRODE CURRENT DENSITY THEORY

An applied **Electrode Current Density** can be defined as its component perpendicular to the boundary according to

$$\mathbf{i}_s \cdot \mathbf{n} = i_{n,s}$$

where

$$\mathbf{i}_s = -\sigma_s \nabla \phi_s$$

and  $\sigma_s$  denotes the electrode conductivity and  $\phi_s$  the electric potential.

The current density can also be defined including all its components:

$$\mathbf{i}_s = \mathbf{i}_{s,\text{bnd}}$$

where  $\mathbf{i}_{s,\text{bnd}}$  is a given expression for the current density vector.

### ELECTRODE POWER THEORY

The Electrode Power boundary condition is used to specify either the total electrode power or the average electrode power density drawn from or inserted into an electrochemical cell at an electrode boundary.

For a total power condition, the boundary electric potential of an electrode is set to a potential  $\phi_{s,\text{bnd}}$ , defined by the condition for the total power on the boundary  $\partial\Omega$  according to

$$\phi_s = \phi_{s, \text{bnd}} \quad \text{on } \partial\Omega$$

$$\int_{\partial\Omega} (\phi_{s, \text{bnd}} - \phi_{s, \text{ground}})(\mathbf{i}_s \cdot \mathbf{n})dS = P_{\text{total}}$$

where  $\phi_{s, \text{ground}}$  is the ground potential of the cell, and  $P_{\text{total}}$  (W) is the power to be drawn.

If a contact resistance  $R_c$  is included, the following current density condition is used:

$$-\mathbf{n} \cdot \mathbf{i}_s = \frac{\phi_{s, \text{bnd}} - \phi_s}{R_c}$$

For an average power condition,  $P_{\text{total}}$  is calculated by

$$P_{\text{total}} = P_{\text{avg}}A$$

where  $P_{\text{avg}}$  is the average power density on the boundary, and  $A$  is the boundary area.



For a galvanic cell, such as a battery during discharge or a fuel cell, there is a maximum power level, beyond which a further current increase causes a lowered output power due to increasing voltage losses. A result of this is that there can be two existing solutions for the same power setting. In these cases the choice of initial values determines the final solution.



Electrode Power

### ION-EXCHANGE MEMBRANE THEORY

Ion-exchange membranes typically contain a polymer matrix with a number of fixed ionic groups.

Since these charges are fixed, there is no need to explicitly model the transport of these charges, but when calculating the sum of charges, used in the Nernst–Planck (with electroneutrality) or the Nernst–Planck–Poisson set of equations, one need to add this fixed space charge.

For Nernst–Planck with electroneutrality, the electroneutrality condition reads

$$\rho_{\text{fix}} + F \sum z_i c_i = 0$$

For the Nernst–Planck–Poisson case, the total space charge density becomes

$$\rho_v = \rho_{\text{fix}} + F \sum z_i c_i$$

### ION-EXCHANGE MEMBRANE BOUNDARY THEORY

The electrochemical potential  $\mu_i$  of a charged species of index  $i$  is

$$\mu_i = RT \ln a_i + \phi_l z_i F$$

where  $T$  (K) is the temperature,  $R$  (mol/(J·K)) the molar gas constant,  $a_i$  is the species activity,  $\phi_l$  is the electrolyte potential,  $z_i$  the species charge, and  $F$  (C/mol) is Faraday's constant.

At equilibrium the electrochemical potentials on each side of the free electrolyte–ion-exchange membrane interface are equal.

Setting the species activity to equal the concentration and denoting the liquid electrolyte phase and an ion-exchange membrane phases as 1 and 2, respectively, the Donnan potential,  $\Delta\phi$  (V), describes the relation between the concentration of a species,  $c_i$  (mol/m<sup>3</sup>), at each side of the boundary and the electrolyte potentials

$$\Delta\phi_l = \phi_{l,1} - \phi_{l,2} = -\frac{RT}{z_i F} \ln \left( \frac{c_{i,1}}{c_{i,2}} \right)$$

which may be rearranged to

$$c_{i,2} = c_{i,1} \exp \left( -\frac{z_i F (\phi_{l,1} - \phi_{l,2})}{RT} \right)$$

The molar flux of each species in the liquid electrolyte is continuous over the membrane–liquid interface

$$\mathbf{n} \cdot \mathbf{J}_{i,1} = \mathbf{n} \cdot \mathbf{J}_{i,2}$$

Since the total current density is the sum of all species fluxes, times the individual species charges, the current densities  $\mathbf{I}_l$  in the normal direction  $\mathbf{n}$  of the membrane–liquid interface boundary is also continuous:

$$\mathbf{n} \cdot \mathbf{I}_{l,1} = \mathbf{n} \cdot \mathbf{I}_{l,2}$$

## *Reference*

---

I. J. O'M. Bockris, A.K.N. Reddy, and M. Gamboa-Aldeco, *Modern Electrochemistry*, vol. 2A, 2nd ed., ch. 7, sec. 7.6, Kluwer Academic/Plenum Press, New York, 2000.

# Theory for the Aqueous Electrolyte Transport Interface

The Aqueous Electrolyte Transport interface models transport of charged and uncharged species, and in addition sets up a charge balance equation for the electrolyte potential.

The species concentrations are denoted,  $c_i$  (SI unit: mol/m<sup>3</sup>), and the potential,  $\phi_l$  (SI unit: V).

The species are transported by diffusion, migration, and (optionally) convection according to the Nernst–Planck set of equations. The total flux of species  $i$  is denoted  $\mathbf{N}_i$  (SI unit: mol/(m<sup>2</sup>·s)) according to

$$\mathbf{N}_i = -D_i \nabla c_i - z_i u_{m,i} F c_i \nabla \phi_l + \mathbf{u} c_i = \mathbf{J}_i + \mathbf{u} c_i \quad (3-6)$$

where  $D_i$  (SI unit: m<sup>2</sup>/s) is the diffusion coefficient,  $z_i$  (1) the corresponding charge,  $u_{m,i}$  (SI unit: s·mol/kg) the mobility and  $\mathbf{u}$  (SI unit: m/s) the velocity vector.  $\mathbf{J}_i$  denotes the molar flux relative to the convective transport (SI unit: mol/(m<sup>2</sup>·s)). For a detailed description of the theory of these equations and the different boundary conditions, see [Theory for the Transport of Diluted Species Interface](#).

## CHARGE BALANCE EQUATION

The current vector,  $\mathbf{i}_l$  (A/m<sup>2</sup>), is defined as

$$\mathbf{i}_l = \sum_i z_i \mathbf{N}_i \quad (3-7)$$

where the summation is made over all species in the electrolyte.

The governing equation for the electrolyte potential is

$$\nabla \cdot \mathbf{i}_l = Q_l \quad (3-8)$$

where  $Q_l$  (SI unit: A/m<sup>3</sup>) is the electrolyte current source stemming from, for example, porous electrode reactions. For nonporous electrode domains this source term is usually zero.

### PROTON AND HYDROXIDE CONCENTRATIONS AND ELECTRONEUTRALITY

Assuming the total number of species to be  $N + 2$ , the assumption of electroneutrality is

$$\sum_{i=1}^{N+2} z_i c_i = 0 \quad (3-9)$$

In water-based systems the species  $H^+$  and  $OH^-$  are always present. The auto ionization reaction for water is



This reaction is fast, following the equilibrium relation

$$c_{H^+} c_{OH^-} = K_w \times 1 \text{ mol}^2 \text{ dm}^{-6} \quad (3-11)$$

where  $K_w \approx 10^{-14}$ .

Now, the electroneutrality condition, including the two additional species  $H^+$  and  $OH^-$ , reads

$$c_{H^+} - c_{OH^-} + \sum_{i=1}^N z_i c_i = 0 \quad (3-12)$$

Combining these two equations results in the following algebraic expressions for the concentrations of  $H^+$  and  $OH^-$ .

$$c_{H^+} = -\frac{\Sigma}{2} + \sqrt{\frac{\Sigma^2}{4} + K_w \times 1 \text{ mol}^2 \text{ dm}^{-6}} \quad (3-13)$$

and

$$c_{OH^-} = \frac{\Sigma}{2} + \sqrt{\frac{\Sigma^2}{4} + K_w \times 1 \text{ mol}^2 \text{ dm}^{-6}} \quad (3-14)$$

where

$$\Sigma = \sum_{i=1}^N z_i c_i \quad (3-15)$$

### MASS BALANCE EQUATIONS FOR DISSOCIATION SPECIES

Assume a set of species  $S_i$  describing  $k$  dissociation steps from

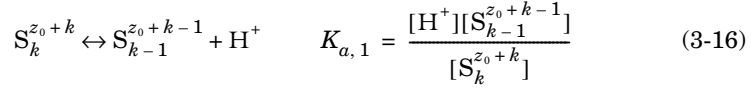

to

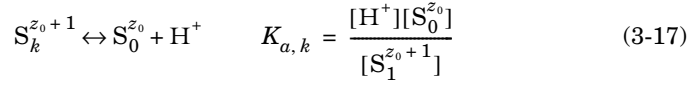

where  $z_0$  is the charge (valence) of species  $S_0$  (which has no dissociable protons) and  $K_{a,j}$  is the acid (equilibrium) constant of the  $j$ th dissociation reaction. The brackets “[ ]” here represent the species activity. The charge of each species is always deductible from the index  $i$  according to  $z_{0+i}$  and will be dropped from now on.

If the proton activity is known, any species  $S_m$  may be expressed using any other species  $S_l$  according to

$$[S_m] = \frac{[H]^{m-l}[S_l]}{k-l} \prod_{j=k-m+1} K_{a,j} \quad (3-18)$$

if  $m > l$  and

$$[S_m] = [H]^{m-l}[S_l] \prod_{j=k-l+1}^{k-m} K_{a,j} \quad (3-19)$$

if  $l > m$ .

Setting  $m = i$  and denoting the flux of species  $i$  by  $\mathbf{N}_i$  using equation [Equation 3-6](#), the mass balance equation for the concentration  $c_i$  of each subspecies  $i$  in the dissociation chain is

$$\frac{\delta c_i}{\delta t} + \nabla \cdot \mathbf{N}_i = R_{\text{eq},i,k-i} - R_{\text{eq},i,k-i+1} + R_i \quad (3-20)$$

where  $R_{\text{eq},i,j}$  is the reaction source stemming from the  $j$ th dissociation step (with  $R_{\text{eq},i,k+1} = 0$ ), and  $R_i$  any additional reaction sources.

The reaction source contributions from the dissociation steps are generally not known, but may be canceled by taking the sum of all mass balance equations, resulting in

$$\sum_{i=0}^k \left( \frac{\delta c_i}{\delta t} + \nabla \cdot \mathbf{N}_i \right) = \sum_{i=0}^k R_i \quad (3-21)$$

### AVERAGE IONIZATION FORMULATION FOR LARGE MOLECULES

Large protein molecules are typically subject to a large number of dissociation steps.

As an alternative way to a long chain of dissociation steps for describing protein transport, you can instead formulate the protein transport based on the average number of protons  $\bar{v}$  (1) removed from the molecule.  $\bar{v}$  is typically provided as a function of pH, based on experimental data. The average charge of the species then is  $\bar{z} = z_0 - \bar{v}$ , so that the flux of the species is written as:

$$\mathbf{N}_i = -D\nabla c_i - \bar{z} u_m F c_i \nabla \phi_l + \mathbf{u} c_i \quad (3-22)$$

and similarly the addition to the charge neutrality condition is  $\bar{z} c_i$ .

When considering the contribution to the current and the charge balance equation you need to take into account that the squared average charge,  $\bar{z}^2 = (z_0 - \bar{v})^2$ , is not equal to the “average squared charge”,  $\bar{z}^2 = z_0^2 + 2z_0\bar{v} + \bar{v}^2 = \bar{z}^2 - \bar{v}^2 + \bar{v}^2$  (Ref. 1).

The addition to the current density vector is

$$\mathbf{i}_l = \dots - F(\bar{z} D_i \nabla c_i + \bar{z}^2 u_m c_i \nabla \phi_l) \quad (3-23)$$

The average number of protons removed from the protein typically depends on the pH. If the average number of removed protons depend only on the pH, the averaged squared number of protons removed can be written as

$$\bar{v}^2 = -c_{\text{H}^+} \frac{d}{dc_{\text{H}^+}} \bar{v} + \bar{v}^2 \quad (3-24)$$

And from this you can derive the average squared charge according to

$$\bar{z}^2 = -c_{\text{H}^+} \frac{d}{dc_{\text{H}^+}} \bar{v} + \bar{z}^2 = -c_{\text{H}^+} \frac{d}{dc_{\text{H}^+}} \bar{z} + \bar{z}^2 \quad (3-25)$$

### DIFFUSIVITY-MOBILITY RELATIONS

For small species, the Nernst–Einstein relation between the diffusivity and the mobility is applicable

$$u_m = \frac{D}{RT} \quad (3-26)$$

### REFERENCES

1. R.A. Mosher, D.A. Saville, and W. Thormann, *The Dynamics of Electrophoresis*, VCH Verlagsgesellschaft mbH, Weinheim, Germany, 1992.
2. R.A. Mosher, P. Gebauer, J. Caslavská, and W. Thormann, “Computer Simulation and Experimental Validation of the Electrophoretic Behavior of Proteins. 2. Model Improvement and Application to Isotachopheresis,” *Anal. Chem.*, vol. 64, pp. 2991–2997, 1992.

# Theory for the Concentrated Electrolyte Transport Interface

In this chapter:

- [Dependent Variables, Species, and Electrolyte Components](#)
- [Volumetric Equations of State](#)
- [Chemical Potentials and the Stefan–Maxwell–Onsager Relations](#)
- [The Reference Electrode](#)
- [Reference](#)

This chapter serves as an introduction of the mathematical framework used for defining the transport equations in the **Concentrated Electrolyte Transport** interface. For a complete description of the theory, including matrix transformations between the species and electrolyte component basis, see [Ref. 1](#).

## *Dependent Variables, Species, and Electrolyte Components*

---

The **Concentrated Electrolyte Transport** interface defines the transport of a total number of  $n$  either positively (cations), negatively (anions), or neutrally charged species in an electrolyte phase. At least one cation and one anion must be defined.

The mathematical framework makes use of a number of electrolyte components that are constructed by forming a set of  $n - 1$  neutral salts based on the  $n$  electrolyte species. It should be noted that the purpose of the neutral electrolyte components is to form a basis for the mathematical framework only; they do not necessarily have any physical correspondence as a real salt in nature. As an example, for an electrolyte composed of the four species  $\text{Mg}^{2+}$ ,  $\text{H}^+$ ,  $\text{OH}^-$ , and  $\text{H}_2\text{O}$ , the set  $\text{Mg}-(\text{OH})_2$ ,  $\text{H}-\text{OH}$ , and  $\text{H}_2\text{O}$  form the corresponding electrolyte component basis.

The mathematical framework expresses variables either in using the individual electrolyte species as a basis or the electrolyte components. The index  $i, j$ , or  $k$  is used generally to define the index of either a species or an electrolyte component. Symbols referring to an electrolyte component are denoted by a tilde ( $\sim$ ) on top of the greek or roman character, whereas indexed symbols without the tilde refer to a species.

Transformations between the species and electrolyte component basis are made by the use of a  $(n \times n)$  transformation matrix  $Z$ , which consists  $n - 1$  rows that define the

stoichiometric coefficients of the species for each electroneutral salt, and with an  $n$ th row defining the individual species charges, divided by the norm of the charge vector.

For the  $\text{Mg}^{2+}$ ,  $\text{OH}^-$ ,  $\text{H}^+$ , and  $\text{H}_2\text{O}$  example, the  $Z$  matrix would look like

$$Z = \begin{bmatrix} 1 & 0 & 2 & 0 \\ 0 & 1 & 1 & 0 \\ 0 & 0 & 0 & 1 \\ \frac{2}{\sqrt{6}} & \frac{1}{\sqrt{6}} & \frac{-1}{\sqrt{6}} & 0 \end{bmatrix} \quad (3-27)$$

For instance, the molar weights  $\tilde{M}_i$  (kg/mol) of the electrolyte component salts can be computed from the first  $n - 1$  rows of the column resulting from the matrix multiplication

$$\tilde{M} = ZM \quad (3-28)$$

where  $M = [M_1 \ M_2 \ \dots \ M_n]^T$  is a column vector of the defined by the individual species molar masses  $M_i$  (kg/mol).

Also the inverse transpose matrix  $Z^{-T}$  is used for various variable basis transformations.

The electroneutrality condition, applied locally at all times, defines the sum of all charges to equal zero

$$\sum z_i c_i = 0 \quad (3-29)$$

where  $z_i$  (dimensionless) are the individual species charges, and  $c_i$  the molar concentrations ( $\text{mol}/\text{m}^3$ ).

Electroneutrality in combination with a volumetric equation of state (see next section), assuming all major constituents of the electrolyte to be included in the electrolyte model, allows for reducing the number of dependent variables by 2, resulting in an equation system consisting of  $n - 1$  electrolyte component fraction  $y_i$  (dimensionless) and one electrolyte potential  $\phi_l$  (V) dependent variables.

### *Volumetric Equations of State*

---

The interplay between molar masses, molar volumes and concentrations will define the total concentration  $c_T$  ( $\text{mol}/\text{m}^3$ ) of species, and the density  $\rho$  ( $\text{kg}/\text{m}^3$ ).

If the average molar volumes  $\tilde{V}_{m,i}$  ( $\text{m}^3/\text{mol}$ ) of the electrolyte components are known, the total concentration of species may be defined as

$$c_T = \frac{1}{\sum_i \tilde{y}_i \tilde{V}_{m,i}} \quad (3-30)$$

and the density as

$$\rho = \sum M_i c_i \quad (3-31)$$

Alternatively, one may define the density  $\rho$  as a function of some of the composition variables, and define the total concentration as

$$c_T = \frac{\rho}{\sum_i \tilde{y}_i \tilde{M}_i} \quad (3-32)$$

### *Flux Definitions and Material Balances*

---

The total flux  $\mathbf{N}_i$  ( $\text{mol}/\text{m}^2/\text{s}$ ) of each individual species is defined as

$$\mathbf{N}_i = \mathbf{j}_i + c_i \mathbf{u} \quad (3-33)$$

where the first term  $\mathbf{j}_i$  represents the diffusive (and migrative) flux and the second term the convective flux, where  $\mathbf{u}$  ( $\text{m}/\text{s}$ ) is the mass-averaged velocity of the electrolyte.

The electrolyte current density  $\mathbf{I}_l$  ( $\text{A}/\text{m}^2$ ) is defined as

$$\mathbf{i}_l = \sum z_i F \mathbf{N}_i \quad (3-34)$$

The material balances for the individual species are defined as

$$\frac{\partial \varepsilon_l c_i}{\partial t} + \nabla \cdot \mathbf{N}_i = R_i \quad (3-35)$$

where  $\varepsilon_l$  (dimensionless) is the electrolyte volume fraction and  $R_i$  the molar source term.

Summing all individual material balances and multiplying by the corresponding species charges results in the charge balance equation for the electrolyte

$$\nabla \cdot \mathbf{I}_l = \sum z_i F R_i \quad (3-36)$$

When formulating the material balances in the interface, it is assumed that the continuity equation for the fluid (which is not solved for by the interface) is fulfilled

$$\frac{\partial \varepsilon_l \rho}{\partial t} + \nabla \cdot (\rho \mathbf{u}) = \sum M_i R_i = Q_m \quad (3-37)$$

This allows for reformulating the individual material balances as

$$\varepsilon_l \frac{\partial c_i}{\partial t} + \nabla \cdot \mathbf{j}_i + \mathbf{u} \cdot \nabla c_i = R_i - \frac{Q_m - \mathbf{u} \cdot \nabla \rho - \varepsilon_l \frac{\partial \rho}{\partial t}}{\rho} \quad (3-38)$$

which is the actual (nonconservative) form of the material balance equation used internally by the interface. This equation form avoids accuracy issues related to evaluating derivatives of the velocity variable.

### *Chemical Potentials and the Stefan–Maxwell–Onsager Relations*

---

Gradients of the electrochemical potentials of the electrolyte species act as driving forces for diffusion and migration in the transport model.

The electrochemical potential  $\mu_i$  (J/mol) of the individual species are defined as

$$\mu_i = \mu_i^0 + RT \ln x_i + RT \ln \lambda_i + F z_i \Phi \quad (3-39)$$

where  $R$  is the molar gas constant (8.31 J/mol/K),  $\mu_i^0$  is the electrochemical potential with respect to some reference state,  $T$  is the temperature (K),  $x_i$  is the molar fraction, the  $\lambda_i$  the species activity coefficient (dimensionless) and  $\Phi$  (V) is the solution potential.

The molar fractions are defined from the species concentrations as

$$x_i = \frac{c_i}{c_T} \quad (3-40)$$

For ideal conditions, the species activity coefficients equal unity. For nonideal solutions, two issues experimental arise in relation to the definition of individual species activity coefficients. The first is that, since charge separation is virtually impossible to achieve in a solution, it is hard to assess the chemical activity of individual ions experimentally. The second is that, since all major species in the solution are

accounted for, one cannot alter the concentration of a single species (or electrolyte salt) without changing the concentration of at least one other compound. To circumvent these issues, activity coefficients are defined in the form of  $(n-1)(n-2)/2$  electroneutral component Darken factors  $\tilde{\Lambda}_{i,j}$  (dimensionless) in an electrolyte component basis as

$$\tilde{\Lambda}_{i,j} = \tilde{v}_i \left( \frac{\partial \ln \tilde{\lambda}_i}{\partial \tilde{y}_j} \right)_{T,p,\tilde{y}_{l \neq j,k}} \quad (3-41)$$

where the derivative should be made keeping the temperature, pressure and all electrolyte components but the ones with index  $j$  and  $k$  constant. In the Concentrated Electrolyte Transport interface, the index  $k$  equals the index of the electrolyte component taken from the molar fraction constraint.

Using the Stefan–Maxwell–Onsager relations, the gradient of the chemical potentials are related to the species fluxes as

$$-\nabla \mu_i = \begin{aligned} & - \sum_{j=1}^n \frac{RT}{c_T D_{ij}} \mathbf{j}_j \quad \text{if } i \neq j \\ & \sum_{j=1}^n \frac{RT}{c_T} \mathbf{j}_j \sum_{k \neq i} \frac{c_k}{D_{ik} c_j} \quad \text{if } i \equiv j \end{aligned} \quad (3-42)$$

where  $D_{ij}$  ( $\text{m}^2/\text{s}$ ) are the binary Maxwell–Stefan diffusivity coefficients. The above equation system is transformed and inverted in order express the electrolyte component fluxes in terms of the gradients of the electrolyte component chemical potentials.

In porous media the binary diffusivities above can be multiplied by an efficiency factor to accommodate for the lowered effective diffusivity due to the lower available volume for transport and tortuosity (topology) effects of the porous matrix.

### *The Reference Electrode*

---

In order to relate the electrolyte phase potential to an experimentally measurable voltage, a reference electrode, defined by its reaction stoichiometric coefficients, is deployed in the model using the generic reaction formula

$$\sum s_i X_i^{z_i} + \sum s'_j Y_j = n_{e, \text{ref}} e^- \quad (3-43)$$

where  $s_i$  and  $X_i$  define the stoichiometric coefficients and species of the electrolyte phase, and  $s'_j$  and  $Y_j$  define the stoichiometric coefficients and species of an adjacent (electrode) phase, respectively, and  $n_{e, \text{ref}}$  the number of electrons participating in the reaction.

The gradient of the electrolyte phase potential, used for defining the chemical potential is defined as

$$\nabla\Phi = \sum \frac{\tilde{s}_i \nabla\tilde{\mu}}{-n_{e, \text{ref}} F} + \nabla\phi \quad (3-44)$$

The stoichiometry of the reference electrode can also be used to define a steady-state convective velocity of the electrolyte for the case when all electrode reactions in a cell have the same stoichiometry as the reference electrode. For this case, the convective velocity can be calculated as

$$\mathbf{u} = \frac{-\mathbf{I}_l}{n_{e, \text{ref}} F \rho} \sum s_i M_i \quad (3-45)$$

### Reference

---

I. A. Van-Brunt, P.E. Farrell, and C.W. Monroe, "Structural electroneutrality in Onsager–Stefan–Maxwell transport with charged species," *Electrochimica Acta*, vol. 441, p. 141769, 2023, [doi.org/10.1016/j.electacta.2022.141769](https://doi.org/10.1016/j.electacta.2022.141769).

# Theory for Electrochemical Heat Sources

Irreversible voltage losses in an electrochemical cell can occur due to the following phenomena:

- Charge transport in the electrolyte (Joule heating)
- Charge transport in the solid conductor materials (Joule heating)
- Activation overpotentials in the electrode reactions
- Heat of mixing

In addition, reversible heat sources and sinks can appear due to the entropy changes in the electrode reactions.

Most Electrochemistry interfaces define and announce heat source variables that can be used by the General Source and the Boundary Heat source nodes in the Heat Transfer interfaces.

An alternative way to couple an electrochemical interface to a heat transfer interface is by the use of the Multiphysics nodes that become available in the model builder tree if there is both a Heat Transfer interface and an Electrochemistry interface available in the same component.

The [Electrochemical Heating](#) multiphysics node defines a domain heat source in the heat transfer interface, based on the sum of irreversible (Joule heating and activation losses) and reversible heat in the electrochemistry interface.

You can also use the heat source variables defined by the electrochemistry interfaces when setting up manual heat couplings between different components in a model. For instance if you are using a 1D electrochemical cell model to calculate an average heat source in a 3D heat transfer model. The names of the heat source variables are `xxx.Qh` (domain, Joule heating and porous electrode reactions) and `xxx.Qbfc` (boundary, electrode surface reactions), where `xxx` is the electrochemistry interface identifier.



- [Electrochemistry Interfaces](#)
  - [Multiphysics Coupling Nodes](#)
-

### *The First Law of Thermodynamics*

---

As a basis for deriving the heat source expressions needed for modeling electrochemical cells, we start from the first law of thermodynamics for a small system (volume element), stating that

$$\delta U = \delta Q - \delta W \quad (3-46)$$

where  $\delta U$  (J) is differential change of the internal energy,  $\delta Q$  (J) is the differential amount of heat added to the system, and  $\delta W$  (J) is the differential work performed by the system element on the surroundings.

Rearranging we may write

$$\delta Q = \delta U - \delta W \quad (3-47)$$

It should be noted that in the absence of pressure or volume changes, which are often neglected in electrochemical models, the differential internal energy equals the differential enthalpy  $\delta H$  (J). In addition, thermodynamic work is usually not involved in electrochemical reactions. We may hence simplify the above to

$$\delta Q = \delta H \quad (3-48)$$

In order to conserve heat, the above differential heat added to the system equals the added heat drawn from the surroundings.

### *Electrochemical Contributions to The Heat Equation*

---

The heat equation solved for by the Heat Transfer interface typically has the following form

$$\rho C_p \frac{\partial T}{\partial t} + \nabla \cdot \mathbf{q} = Q \quad (3-49)$$

where  $Q$  is the domain heat source ( $\text{W}/\text{m}^3$ ).

The electrochemistry interfaces typically solve for the transport and electrochemical reactions of a multicomponent system comprising a number of different species with index  $i$ . Adding the additional contributions from the multicomponent system to the heat transfer equation, and assuming no other additional heat sources ( $Q = 0$ ), results in

$$\rho C_p \frac{\partial T}{\partial t} + \nabla \cdot (\mathbf{q} + H_i \mathbf{N}_i) = -H_i \frac{\partial c_i}{\partial t} \quad (3-50)$$

where  $H_i$  is the partial molar enthalpy (J/mol),  $\mathbf{N}_i$  is the species flux (mol/m<sup>2</sup>/s), and  $c_i$  is the concentration.

By treating the contributions from the electrochemical multicomponent system as a heat source defined as

$$Q = -\left(\sum_i \nabla \cdot (H_i \mathbf{N}_i) + H_i \frac{\partial c_i}{\partial t}\right) \quad (3-51)$$

Equation 3-49 can be made to represent the heat transfer equation of a multicomponent electrochemical system.

Writing the general material balance for each species as

$$\frac{\partial c_i}{\partial t} + \nabla \cdot \mathbf{N}_i = R_i \quad (3-52)$$

where  $R_i$  (mol/m<sup>3</sup>/s) is the local rate production source, the heat source expression may be simplified to

$$Q = -\left(\sum_i \nabla H_i \cdot \mathbf{N}_i + H_i R_i\right) \quad (3-53)$$

where the second term may be used to define the reaction enthalpies of non-Faradaic reactions (for Faradaic reactions, see below).

The derivations below follow a simplified approach along the principles lined out in Ref. 1. For deepened discussion on thermal effects in electrochemical cells, the reader is referred to Ref. 1 to Ref. 4.

In the derivations, the partial molar species enthalpies are defined as

$$H_i = \bar{H}_i + z_i F \nabla \phi \quad (3-54)$$

where  $\bar{H}_i$  is the potential-independent partial molar enthalpy (J/mol) and  $\phi$  the electrostatic potential (V). Apart from when heat of mixing effects are present,  $\bar{H}_i$  is constant.

### *Joule Heating Due to Charge Transport*

---

To derive the heat source for Joule heating we assume a domain where there are no species sources, nor heat of mixing effects present.

As charged species travel in an electric field, the enthalpy changes according to the gradient in the electric potential  $\phi$  (V)

$$\nabla H_i = z_i F \nabla \phi \quad (3-55)$$

where  $z_i$  is the species charge.

For a current conductor, the only species carrying charge is the electron, with a negative unit charge. The electron flux is related to the current density  $\mathbf{i}_s$  as

$$\mathbf{N}_e = -\frac{\mathbf{i}_s}{F} \quad (3-56)$$

resulting in

$$\mathbf{Q}_s = -(\mathbf{i}_s \cdot \nabla \phi_s) \quad (3-57)$$

where the subscript  $s$  denotes the electron conducting phase.

For the electrolyte phase, the heat source becomes

$$\mathbf{Q}_l = -\sum_i \nabla(z_i F \phi_l) \cdot \mathbf{N}_i = -\nabla \phi_l \cdot \sum_i z_i F \mathbf{N}_i = -\nabla \phi_l \cdot \mathbf{i}_l \quad (3-58)$$

For a homogenized porous electrode domain, the Joule heating term for both phases are added together:

$$\mathbf{Q}_{\text{JH}} = -(\mathbf{i}_s \cdot \nabla \phi_s + \mathbf{i}_l \cdot \nabla \phi_l) \quad (3-59)$$

### *Heating Due to Electrochemical Reactions*

---

A heat source variable for a boundary defining an electrode-electrolyte interface (electrode surface) may be derived by considering the net enthalpy flux into the interface

$$q = -\left(-\frac{H_e}{F} + \sum_i \frac{\nu_i H_i}{nF}\right) i_{\text{loc}} \quad (3-60)$$

where  $q$  is the boundary heat source ( $\text{W}/\text{m}^2$ ),  $n$  and  $\nu_i$  are the number of electrons participating in the reaction and the stoichiometric coefficients of the reaction, respectively, and  $i_{\text{loc}}$  local current density at the electrode surface. Subscript  $e$  above denotes the electron, and  $i$  the electrolyte phase species.

Considering the overall charge neutrality of the electrode reaction

$$n = -\sum_i \nu_i z_i \quad (3-61)$$

and rearranging, the above relation equates to

$$q = \left( -\frac{\Delta H}{nF} - (\phi_s - \phi_l) \right) i_{\text{loc}} \quad (3-62)$$

where  $\Delta H$  is the potential-independent net partial molar enthalpy change, defined as

$$\Delta H = \sum_i \nu_i \bar{H}_i - n \bar{H}_e \quad (3-63)$$

Defining the thermoneutral voltage of the reaction as

$$E_{\text{therm}} = -\frac{\Delta H}{nF}$$

the heat source term can be also be written as

$$q = (E_{\text{therm}} - (\phi_s - \phi_l)) i_{\text{loc}} \quad (3-64)$$

Alternatively, using the relation

$$\Delta G = \Delta H - T\Delta S$$

where  $\Delta G$  is the Gibbs free energy of the reaction, and where  $\Delta S$  is the net entropy change, and defining the equilibrium potential as

$$E_{\text{eq}} = -\frac{\Delta G}{nF} \quad (3-65)$$

the boundary heat source may also be written as

$$q = \left( \eta + T \frac{\partial E_{\text{eq}}}{\partial T} \right) i_{\text{loc}} \quad (3-66)$$

where the overpotential is defined as

$$\eta = \phi_s - \phi_l - E_{\text{eq}} \quad (3-67)$$

and the temperature derivative of the equilibrium potential is defined as

$$\frac{\partial E_{\text{eq}}}{\partial T} = \frac{\Delta S}{nF} \quad (3-68)$$

The total heat source due to the electrochemical reactions,  $q_{EC}$ , for an electrode surface is the sum of all individual heat sources of the electrode reactions according to

$$q_{EC} = \sum_m q_m$$

where  $m$  is the index of the electrode reaction.

For a homogenized formulation of a porous electrode, the domain heat sources due to electrochemical reactions can be obtained by multiplying by the internal surface area  $a_{v,m}$  ( $\text{m}^2/\text{m}^3$ ). For a porous electrode, the electrochemical sources are hence summed up according to

$$Q_{EC} = \sum_m a_{v,m} Q_m$$

---

### *Heating Due to Heat of Mixing*

If the partial molar enthalpy varies with the local concentration of the species, there are also heat of mixing sources associated with the concentration gradients. These heat of mixing effects are typically small (zero for ideal gases) and are generally not included in the Electrochemistry interfaces.

---

### *Total Overpotential Calculation for Concentration Dependent Kinetics*

When using the Concentration dependent kinetics option in the Porous Electrode Reaction and Electrode Reaction nodes, the equilibrium potential is typically a constant referring to a reference state, and the concentration dependence of the kinetics is accounted for only in the pre-exponential terms according to

$$i_{\text{loc},m} = i_{0,m} \left( C_{R,m} \exp\left(\frac{\alpha_{a,m} F \eta_m}{RT}\right) - C_{O,m} \exp\left(\frac{-\alpha_{c,m} F \eta_m}{RT}\right) \right)$$

where

$$\eta_m = \phi_s - \phi_l - E_{\text{eq},m}$$

A result of this is that, when the pre-exponential factors  $C_{O,m}$  and  $C_{R,m}$  differ due to concentration gradients, there can at zero activation overpotential be a net charge-transfer current density flowing over the electrode–electrolyte interface. This local current density should obviously give rise to a heat source. The solution is to add a concentration overpotential term to the total overpotential when calculating the heat sources.

When using the Concentration dependent kinetics option, the overpotential, used in the irreversible heat term above, is calculated as follows:

$$\eta_{m, \text{tot}} = \phi_s - \phi_l - E_{\text{eq}, m} + \eta_{m, \text{conc}}$$

where

$$\eta_{m, \text{conc}} = \frac{RT}{n_m F} \ln \frac{C_{O,m}}{C_{R,m}}$$

If the number of electrons is not available,

$$n_m = \alpha_{a,m} + \alpha_{c,m}$$

is assumed.

## References

---

1. John Newman, “Thermoelectric Effects in Electrochemical Systems,” *Ind. Eng. Chem. Res.*, vol. 34, no. 10 pp. 3208–3216, 1995
2. Bernardi and others, “A General Energy Balance for Battery Systems,” *J. Electrochem. Soc.*, vol. 132, pp. 5–12, 1985.
3. Thomas and others, “Thermal Modeling of Porous Insertion Electrodes,” *J. Electrochem. Soc.*, vol. 150, pp. A176–A192, 2003.
4. J. Newman and K.E. Thomas-Alyea, *Electrochemical Systems*, Chapter 13 Thermal Effects, Wiley, 2012.

# Theory for Electrochemical Power Losses

Most Electrochemistry interfaces define power loss variables that can be used to analyze the performance of electrochemical cells. The power loss variables are derived using similar principles as for the electrochemical heat source variables, but with the fundamental difference that the power loss variables are based on interfacial changes and domain gradients in the Gibbs free energy, rather than the enthalpy. In the absence of entropy changes, the power loss and the heat source variables are identical.

## KINETIC ACTIVATION POWER LOSSES

On an electrode surface, the local power loss ( $\text{A}/\text{m}^2$ ) equals the local electrode reaction current density times the overpotential

$$p_{\text{loss}} = i_{\text{loc}} \eta \quad (3-69)$$

whereas in a homogenized porous electrode model, the local power loss ( $\text{A}/\text{m}^3$ ) equals the volumetric electrode reaction current density times the overpotential

$$p_{\text{loss}} = i_v \eta \quad (3-70)$$

## ELECTROLYTE TRANSPORT POWER LOSSES

Power loss associated with transport is based on gradients in the chemical potentials of the transported species. (The chemical potential equals the Gibbs free energy per mole of that species). For an electrolyte species  $i$ , the electrochemical potential gradient ( $\text{J}/\text{mol}/\text{m}$ ) is defined as

$$\nabla \mu_i = \nabla (RT \ln c_i + z_i F \phi_l) \quad (3-71)$$

This definition assumes that the Nernst–Einstein equation applies for the definition of the electrolyte mobility, and that the equilibrium potential of all electrode reactions exhibit a Nernstian (logarithmic) concentration dependency. For non-ideal activities, the  $c_i$  is replaced by  $a_i$ .

The electrolyte power loss associated with the transport of the species  $i$  is then defined as

$$p_{\text{loss},i} = -\nabla \mu_i \cdot \mathbf{N}_{\text{md},i} \quad (3-72)$$

where  $\mathbf{N}_{\text{md},i}$  is the migrative-diffusive flux of species  $i$  with respect to the mass-averaged, or solvent, convective velocity of the electrolyte which relates to the total molar flux  $\mathbf{N}_{\text{tot},i}$  as

$$\mathbf{N}_{\text{md},i} = \mathbf{N}_{\text{tot},i} - c_i \mathbf{v} \quad (3-73)$$

where  $\mathbf{v}$  is the velocity.

The total power loss due to electrolyte transport is defined as

$$P_{\text{loss}} = \sum P_{\text{loss},i} \quad (3-74)$$

Recognizing that the total electrolyte current vector equals

$$\mathbf{i}_l = F \sum z_i \mathbf{N}_{\text{md},i} \quad (3-75)$$

it is possible to split the total power loss into an entropic and ohmic part defined as

$$P_{\text{loss,entropic}} = \sum -\nabla RT \ln c_i \cdot \mathbf{N}_{\text{md},i} \quad (3-76)$$

and

$$P_{\text{loss,ohmic}} = \sum -F z_i \nabla \phi_l \cdot \mathbf{N}_{\text{md},i} = -\nabla \phi_l \cdot \mathbf{i}_l \quad (3-77)$$

# Theory for the Electrode, Shell Interface

The [Electrode, Shell Interface](#) defines electrode current conduction in a thin shell on a boundary. The electrolyte current distribution in the adjacent domain is typically solved for by a separate physics interface.

In this section:

- [Governing Equations](#)
- [Coupling to Other Physics Interfaces](#)

## *Governing Equations*

---

The Electrode, Shell interface solves for the electric potential  $\phi_s$  (SI unit: V) on a boundary, using the following governing equation:

$$\nabla_T \cdot (s \mathbf{i}_s) = -i_n \quad (3-78)$$

where  $\nabla_T$  is the tangential gradient operator,  $s$  (SI unit: m) is the electrode layer thickness, and  $i_n$  (SI unit: A/m<sup>2</sup>) are the sum of all currents flowing out from the electrode (in the normal direction to the boundary). Furthermore,  $\mathbf{i}_s$  (SI unit: A/m<sup>2</sup>) is the tangential current density vector along the electrode boundary, defined as

$$\mathbf{i}_s = -\nabla_T \sigma_s \phi_s \quad (3-79)$$

where  $\sigma_s$  is the electric conductivity (SI unit: S/m). The next section discusses [Coupling to Other Physics Interfaces](#).

## *Coupling to Other Physics Interfaces*

---

### **ELECTRODE POTENTIAL IN OTHER PHYSICS INTERFACES**

Typically the boundary electric potential in the Electrode Surface node is set to the electric potential in the Electrode, Shell interface.

### **ELECTRODE REACTION CURRENTS**

The sum of currents can be coupled to other electrochemistry interfaces, calculating  $i_n$  as

$$i_n = i_{\text{tot}}$$

where  $i_{\text{tot}}$  (SI unit: A/m<sup>2</sup>) is the sum of all electrode currents in the coupled Electrochemistry interface.

#### **ELECTRODE LAYER THICKNESS**

The electrode thickness,  $s$ , can typically be coupled to an External Depositing Electrode (External Corroding Electrode) node in the Electrodeposition, Moving Mesh (Corrosion, Moving Mesh) interface, in that case  $s$  is calculated as

$$s = s_0 + \Delta s_{\text{tot}} \quad (3-80)$$

where  $s_0$  is the initial electrode layer thickness, and  $\Delta s_{\text{tot}}$  is the electrode thickness change, calculated by the coupled Electrochemistry interface.

#### **HEAT SOURCE**

The electron conduction gives rise to a Joule heating source  $Q_H$  (SI unit: W/m<sup>2</sup>) according to

$$Q_H = -s \mathbf{i}_s \cdot \nabla_t \phi_s$$

# Theory for Electroanalysis

The theory related to the **Electroanalysis** charge conservation model in [The Tertiary Current Distribution, Nernst–Planck Interface](#) (tcd) is described in this section:

- [Electroanalytical Methods](#)
- [Supporting Electrolyte](#)
- [Domain Equations for the Electroanalysis Case](#)
- [Electrode Boundary Conditions in the Electroanalysis Model](#)
- [The Electroanalytical Butler–Volmer Equation](#)
- [Counter Electrodes and Overall Charge Balance](#)

## *Electroanalytical Methods*

---

*Electroanalysis* is the science of quantitative electrochemical measurement of the composition or properties of a chemical system. Common electroanalytical methods include: (cyclic) voltammetry, (chrono)amperometry, potentiometry, coulometry, and electrochemical impedance spectroscopy (EIS). These methods are experiments performed either in a static electrolyte solution or in an electrolyte solution subject to a forced fluid flow. The results sought in electroanalysis include:

- Measurement of the concentration of an analyte — for example, glucose, or a gas-phase species that dissolves in the electrolyte solution. This technique is often referred to as *electrochemical sensing*. The most common sensing method is by recording the concentration-dependent current due to an analyte-specific reaction: this is called *amperometric sensing*.
- Measurement of the kinetic and/or thermodynamic parameters describing an electrochemical reaction on a given electrode surface.
- Measurement of the transport properties of an electroactive chemical species.
- Investigation of the mechanism of an electrochemical reaction and the further reactivity of the electrochemically generated chemical species.

## *Supporting Electrolyte*

---

When performing electroanalytical experiments, it is conventional to add a large quantity of inert salt to the solution — this artificially added salt is called *supporting*

*electrolyte*. The purpose of the supporting electrolyte is to increase the conductivity of the solution, and hence to eliminate the electric field from the electrolyte.

A negligible electric field provides two advantages for electroanalysis:

- The voltage due to the resistance of the electrolyte when the cell draws current (“ohmic drop”) is minimal. Therefore, the potential difference applied across the electrochemical cell is localized at the electrode–electrolyte interfaces, and so the activation overpotential perceived by the redox couple at this interface is almost exactly proportional to the applied cell voltage. The kinetic behavior of the electrochemical cell then has no explicit dependence on the magnitude of the drawn current.
- The contribution of migration to the transport of charged chemical species is negligible compared to the contribution of diffusion (and of convection, in a forced flow). Therefore the transport properties of the system are linearized, and they do not depend on the magnitude of the drawn current.

These properties greatly simplify the design and analysis of electroanalytical experiments. Therefore, the use of a supporting electrolyte is very common in electrochemical sensing and electroanalysis.



The amount of supporting electrolyte required for the assumption of zero electric field to be sound is dependent on the system. Typically it becomes valid when the concentration of inert salt exceeds the concentration of analyte by a factor of 10–100, but this is not always the case.

---

Even for the conductivities of electrolyte solutions in the presence of excess supporting electrolyte, the electric field is not negligible if significant current density is drawn. Electroanalysis typically draws small currents because the purpose is measurement. In processes where an electrochemical reaction is driven — such as electrolysis, electrodeposition, batteries, and fuel cells — current densities are typically much larger, so that the desired extent of reaction is achieved in a reasonable time. Under these conditions, significant electric fields are likely and other charge conservation models should be used instead of the Electroanalysis option.

### *Domain Equations for the Electroanalysis Case*

---

The Electroanalysis option assumes that the electric field is zero, and so the electrolyte potential is constant. Since you can arbitrarily choose to ground the electrolyte potential at any point, set it to  $\phi_l = 0$ .

This is equivalent to the assumption of infinite electrolyte conductivity. Therefore the Electroanalysis option does not solve for charge transfer within domains, because current density is not meaningfully defined within the electrolyte.

The transport of chemical species in an electrolyte solution obeys the Nernst–Planck equation for the flux of species  $i$ :

$$\mathbf{N}_i = -D_i \nabla c_i - z_i u_{m,i} F c_i \nabla \phi_l + c_i \mathbf{u} = \mathbf{J}_i + c_i \mathbf{u}$$

Here  $\mathbf{J}_i$  denotes the molar flux relative to the convective transport.

At zero electric field, this reduces to:

$$\mathbf{N}_i = -D_i \nabla c_i + c_i \mathbf{u} \quad (3-81)$$

where the only contributions to the flux of a chemical species are from diffusion and convection respectively. In the absence of convection (no fluid flow,  $\mathbf{u} = 0$ ), this is also known as *Fick's first law of diffusion*:

$$\mathbf{N}_i = \mathbf{J}_i = -D_i \nabla c_i$$

A mass balance also applies to each chemical species:

$$\frac{\partial c_i}{\partial t} + \nabla \cdot \mathbf{N}_i = R_{i, \text{tot}} \quad (3-82)$$

The Electroanalysis charge conservation model solves [Equation 3-81](#) and [Equation 3-82](#) for the unknown concentrations of each chemical species under analysis.

This combination is often written as a single equation for the unknown  $c_i$ . For zero convection, zero reaction, and a constant diffusion coefficient, the domain equation is:

$$\frac{\partial c_i}{\partial t} = D_i \nabla^2 c_i \quad (3-83)$$

Equation 3-83 is *Fick's second law of diffusion*.



The Electroanalysis charge conservation model is not suitable to explicitly model the transport of the supporting electrolyte, since the migration of the supporting electrolyte is always its dominant mode of mass transport. For a coupled model including the chemical species of all charge-carrying species, use the electroneutrality model in Tertiary Current Distribution, Nernst–Planck interface.



You can also include additional chemical species and reactions that are not involved in the electrochemical reaction.



- [Electrode Potentials and Reference Electrodes](#)
- [The Tertiary Current Distribution, Nernst–Planck Interface](#)

### *Electrode Boundary Conditions in the Electroanalysis Model*

The *activation overpotential* at an electrode–electrolyte interface with respect to the electrode reaction  $m$  is defined as:

$$\eta_m = \phi_s - \phi_l - E_{\text{eq},m}$$

This is the potential difference perceived by a redox couple, measured against the equilibrium potential of the couple; it provides the thermodynamic driving force for an electrochemical reaction by faradaic charge transfer between the electrode and the electrolyte domains.

Subject to the approximation of constant electrolyte potential ( $\phi_l = 0$ ), this equation reduces to:

$$\eta_m = \phi_s - E_{\text{eq},m}$$

The activation overpotential is independent of the properties of the adjacent electrolyte. It only depends on the applied electrode potential  $\phi_s$  and the equilibrium potential of the redox couple, where both are measured against a common reference potential.

The current density due to an electrode reaction at a point on an electrode surface is computed using an electrochemical rate expression. For most practical electroanalytical applications, the rate depends on the local concentration which varies during the study, and so the most relevant expression is [The Electroanalytical Butler–Volmer Equation](#).



## Electrode Kinetics Expressions

The flux  $N_i$  of the chemical species  $i$  (SI unit: mol/m<sup>2</sup>) across an electrode surface depends on the current densities  $i_m$  associated with the electrode reactions  $m$  according to *Faraday's laws of electrolysis*. These can be written as:

$$N_i = \sum_m \frac{\nu_{i,m} i_m}{n_m F} \quad (3-84)$$

where  $\nu_{i,m}$  is the stoichiometric coefficient of species  $i$  with respect to reaction  $m$  (in the reductive direction), and  $n_m$  is the number of transferred electrons.  $F$  is the *Faraday constant*, which is the charge on a mole of electrons (96485.3365 C/mol).

The surface flux is applied as a boundary condition:

$$N_i = \mathbf{N}_i \cdot \mathbf{n} \quad (3-85)$$

[Equation 3-84](#) and [Equation 3-85](#) constitute the coupling between charge balance and mass balance. This coupling only applies at the electrode–electrolyte interface, which is a boundary to the domain where the electroanalysis charge conservation model solves for chemical species transport.

The total current density is the sum of faradaic (electrode reaction) components and nonfaradaic components ( $i_{\text{nf}}$ ) such as current due to [Double-Layer Capacitance](#):

$$i_{\text{total}} = \sum_m i_{\text{loc}, m} + i_{\text{nf}}$$

The experimentally measurable total current  $I$  (SI unit: A) drawn at an electrode can be computed by integration of the local current density (SI unit: A/m<sup>2</sup>) across the electrode area:

$$I_{\text{total}} = \int_{\partial\Omega} i_{\text{total}} ds$$



## Domain Equations for the Electroanalysis Case

### *The Electroanalytical Butler–Volmer Equation*

A one-electron electrochemical reaction between two solution-phase species can be written as a reduction  $\text{Ox} + e^- \leftrightarrow \text{Red}$ .

Ox and Red represent the oxidized and reduced forms of the chemical species, respectively.

The most general equation to describe the rate of this reaction as it proceeds at an electrode surface is the electroanalytical *Butler–Volmer equation*:

$$i_{\text{loc}} = k_0 F \left( c_{\text{Red}} \exp\left(\frac{\alpha_a F \eta}{RT}\right) - c_{\text{Ox}} \exp\left(\frac{-\alpha_c F \eta}{RT}\right) \right) \quad (3-86)$$

where  $k_0$  is the *heterogeneous rate constant* (SI unit: m/s) and  $\alpha_c$  is the (cathodic) transfer coefficient (dimensionless). For a one-electron reduction, the anodic and cathodic transfer coefficients are related as  $\alpha_a + \alpha_c = 1$ .

When the current is zero, the electroanalytical Butler–Volmer equation can be rearranged to the thermodynamic *Nernst equation* relating the equilibrium concentrations of the reacting species:

$$c_{\text{Red}} = c_{\text{Ox}} \exp\left(\frac{-F E_{\text{eq}}}{RT}\right)$$

Where the flux of the reacting species is negligible compared to the concentration of these species, the concentrations are roughly constant ( $c_{\text{Red}} \sim c_{\text{Ox}} \sim c$ ). This converts [Equation 3-86](#) into the Butler–Volmer equation written in terms of an exchange current density  $i_0$  (SI unit:  $\text{A}/\text{m}^2$ ):

$$i_{\text{loc}} = i_0 \left( \exp\left(\frac{\alpha_a F \eta}{RT}\right) - \exp\left(\frac{-\alpha_c F \eta}{RT}\right) \right)$$

The exchange current density  $i_0$  (SI unit:  $\text{A}/\text{m}^2$ ) is then related to the heterogeneous rate constant as  $i_0 = k_0 F c$ .

### *Counter Electrodes and Overall Charge Balance*

---

The Electroanalysis charge conservation model does not solve explicitly for the electrolyte potential in the domains. This has the implication that an overall charge balance of a modeled cell does not follow naturally as a result of the domain potential equation (as is the case for instance when solving for Ohm's law in the Secondary Current Distribution interface).

In order to model a charge balance of a cell with an arbitrary number of working electrodes and counter electrodes, the solution is to add an extra degree of freedom for the counter electrode potential,  $\phi_{s, CE}$ , and then solve for this potential to fulfill the following current balance over all electrode surfaces:

$$\phi_{s, CE}: \int_{\text{electrodes}} i_{\text{tot}} dS = 0 \quad (3-87)$$

The counter electrode potential is used in the overpotential,  $\eta$ , in the kinetics expression(s) on the counter electrode.

$$\eta_m = \phi_{s, CE} - E_{\text{eq}, m} \quad (3-88)$$

Note that only one counter electrode potential degree of freedom is added in the model, regardless of the number of counter electrodes that are active.



# Electrode Potentials and Reference Electrodes

In all the Electrochemistry branch interfaces, the dependent potential variables are  $\phi_s$  (SI unit: V), the electric potential of the electrode phase (the electron conductor, such as metal), and  $\phi_l$  (SI unit: V), the potential of the electrolyte phase (ion conductor).

Typically the kinetics of the electrochemical reactions are defined using the overpotential,  $\eta$  (SI unit: V), defined as

$$\eta = \phi_s - \phi_l - E_{\text{eq}} \quad (3-89)$$

where  $E_{\text{eq}}$  (SI unit: V) is the equilibrium potential. If it is to apply for all overpotentials, a general kinetic expression for an electrode reaction must be set up so that the charge-transfer current over the electrolyte-electrode interface is zero for zero overpotential (equilibrium conditions).

An implication of [Equation 3-89](#) is that it is the potential difference,  $\phi_s - \phi_l$ , that governs the kinetics, not the absolute individual values of  $\phi_s$  and  $\phi_l$ . A global change in the reference for both potentials has no impact on the electrode kinetics. As a result of this, the potentials have to be “boot-strapped” in a model in some way, typically by making an arbitrary choice of electric ground — for example, on an exterior boundary — in order to ensure that there is a unique solution to the problem.

In this section:

- [Reference Electrodes](#)
- [Boundary Conditions Using Reference Electrode Potentials](#)
- [Nodes for Handling Electrode Potentials and Reference Electrodes](#)

## *Reference Electrodes*

---

In experimental electrochemistry, it is common to use *reference electrodes* when controlling current or voltage with a potentiostat. Potential differences in the system are recorded with respect to the equilibrium potential of the redox couple at the reference electrode. A good reference electrode is designed so that no net charge transfer takes place at its electrode-electrolyte interface. Then the overpotential of the reference is zero, so:

$$\phi_{s, \text{ref}} = \phi_l + E_{\text{eq, ref}} \quad (3-90)$$

where  $\phi_{s, \text{ref}}$  (SI unit: V) is the electric potential of the reference electrode and  $E_{\text{eq, ref}}$  (SI unit: V) is the equilibrium potential of the reference electrode reaction.

The electric potentials of the electrodes in the electrochemical cell can then be defined with respect to the reference electrode according to:

$$E_{\text{vs ref}} = \phi_s - \phi_{s, \text{ref}} \quad (3-91)$$

where  $E_{\text{vs, ref}}$  (SI unit: V) is the electrode potential versus the reference potential.

It is important to realize that the presence of an ideal reference electrode in the system has no impact on the physics; the only purpose of the reference electrode is to define a stable reference point for the potential levels.

### *Boundary Conditions Using Reference Electrode Potentials*

---

The set of boundary conditions defined in a model of an electrochemical cell needs to ensure that no current flows through the reference electrode. A constraint for the potential on the actual reference electrode is not suitable in general since it can create unwanted local sources or sinks of current.

When modeling the control of an electrochemical cell by a *potentiostat*, which monitors and controls the potential of an electrodes versus a reference electrode, the electric potential conditions should be applied to the boundaries over which the current flows in the cell. One electrode (the counter electrode) is typically grounded, whereas an electric potential condition is set on all other (working) electrode boundaries according to

$$\phi_{s, \text{bnd}} = E_{\text{vs ref}} + \phi_{s, \text{ref}} \quad (3-92)$$

where  $\phi_{s, \text{bnd}}$  (SI unit: V) is the applied electric boundary potential on the electrode.

### *Nodes for Handling Electrode Potentials and Reference Electrodes*

---

The [Reference Electrode](#) node is a point feature applicable to electrolyte domains (in all the Electrochemistry interfaces). It defines a global electric reference potential  $\phi_{s, \text{ref}}$  (SI unit: V) according to [Equation 3-90](#). The  $\phi_{s, \text{ref}}$  can be used in the Electrode Potential feature for setting the electric potential of an electrode boundary with respect to the reference potential. The variable  $E_{\text{vs, ref}}$  (SI unit: V), according to [Equation 3-91](#), is also defined in all electrode domains.

The **Electric Reference Potential** node is a point feature applicable to electrode domains (in all the Electrochemistry interfaces). It defines a global electric reference potential  $\phi_{s,\text{ref}}$  (SI unit: V) equal to the dependent variable  $\phi_s$  (SI unit: V) in the point. The  $\phi_{s,\text{ref}}$  can be used in the Electrode Potential feature for setting the electric potential of an electrode boundary with respect to the reference potential.

Whenever a  $\phi_{s,\text{ref}}$  is defined, the variable  $E_{\text{vs,ref}}$  (SI unit: V), according to [Equation 3-91](#), is also defined in all electrode domains.

The **Electrode Potential** is a boundary condition feature, applicable to exterior boundaries of electrode domains (in all the Electrochemistry interfaces). It sets a boundary condition for the electric potential with respect to a defined reference potential according to [Equation 3-92](#). Electric potentials defined by the Electric Reference Potential and Reference Electrode point feature can be used as input when specifying the Electrode Potential feature.

An Electrode Potential alternative in the Boundary Condition settings list is also available for the Electrode Surface node.

The variable  $E_{\text{vs,ref}}$  (SI unit: V), according to [Equation 3-91](#), is also defined on these features.

# Solving Electrochemical Models

Due to the highly nonlinear nature of electrode kinetics, some electrochemical models can be difficult to solve. This section includes some general tips and tricks to facilitate model solving, troubleshooting, and ways to improve solution accuracy.

Usually, convergence issues occur due to, and are resolved by correcting, settings in the physics (inconsistent parameter values, missing initial values, lacking boundary conditions, and so on), rather than actual solver settings.



[Studies and Solvers](#) and [Building a COMSOL Multiphysics Model](#) in the *COMSOL Multiphysics Reference Manual*

---

## *General Current Distribution Problems*

---

Start with the following suggestions if you encounter difficulty solving a stationary problem or finding consistent initial values for a time-dependent problem.

- Make sure that the potential levels are boot-strapped somewhere in the model, preferably by grounding one electrode.
- Consider using a **Stationary with Initialization** or a **Time-dependent with Initialization** study. Both these studies will use a **Current Distribution Initialization** study step as a first step to solve for the potentials only. If you run into problems solving for the second step in this study you may have to change the **Current distribution type** setting to **Secondary** on the **Current Distribution Initialization** study step node, and also review the **Initial Values** as described in the next bullet. Alternatively you can add a second **Current Distribution Initialization** study step node, set to **Secondary**, after the first (**Primary**) **Current Distribution Initialization** study step in the study sequence.
- If you are not using a (**Primary**) **Current Distribution Initialization** study step, review the **Initial Values** for the potentials. Suitable initial potential values can usually be derived making a “potential walk” through the geometry, starting at the grounded boundary expected to deviate the least from equilibrium (usually the one with the fastest kinetics, for instance the hydrogen electrode in a PEM fuel cell) and assuming zero overpotentials for the main electrode reactions.

- Switch to **Linearized Butler–Volmer** kinetics while troubleshooting. This can be useful to help achieve a solution for a model that does not solve with nonlinear kinetics, thereby indicating suitable initial values for the nonlinear problem.
- If your model contains porous electrodes, try refining the mesh resolution in these domains, especially toward the electrolyte boundaries.



- [Electrochemistry Interfaces](#)
  - [Specifying Initial Values](#) and [Inspecting and Troubleshooting Meshes](#) in the *COMSOL Multiphysics Reference Manual*
- 

### *Electrochemistry Coupled to Mass Transport, Battery, and Tertiary Current Distribution Models*

---

If the model involves electrochemistry coupled to mass transport, here are a few things to try to help improve model convergence.

- Review the **Initial Values** for the concentration values. Zero initial concentration values can cause issues in tertiary current distributions and battery simulations since that could imply that no charge carriers or no reacting material is present initially.
- If steep concentration gradients are expected close to electrode surfaces, use boundary layer meshing or finer size settings at these boundaries.
- When setting up user-defined kinetics expressions, avoid evaluating negative concentrations by using expressions such as  $\max(c, \text{eps}^2)$ , where  $\text{eps}$  is the machine epsilon; that is, it is a very small floating-point number.
- Try to solve for low currents or low overpotentials first, then increase the cell load (for stationary problems this can be done using an **Auxiliary Sweep** with **Continuation** enabled).
- If a problem involving mass transport is hard to solve for high currents, but solves for low currents, it might be due to mass transport limitations. In this case, review the transport parameter values and check that the current magnitudes are

reasonable. If the current densities are unreasonably high, review the electrode reaction settings.

- 
- [Electrochemistry Interfaces](#)

In the *COMSOL Multiphysics Reference Manual*:



- [2D and 3D Boundary Layer Meshes](#)
  - [Stationary and Parametric Sweep](#)
- 

### *Setting up a Study Sequence for Multiphysics Problems*

---

For multiphysics problems, try to adjust the study sequence.

- Solve certain physics interfaces in a sequence. This can in many cases reduce computational time and improve convergence. Analyzing the results when solving a physics interface separately can also help when troubleshooting a nonconverging model.
- A good strategy is often to solve for the potentials only (that is, disable mass transport and flow interfaces), using a stationary study step, before solving the full model in the study sequence. In this way the stationary solution is used as initial values for the following steps. This can be manually by modifying the settings of the study node, or in an automated way by using the using **Stationary with Initialization** or a **Time-dependent with Initialization** study as described above.
- In many models the flow profile is only slightly (or not at all) affected by changes in current density. Therefore it can be a good strategy to separately solve for the flow early in the study sequence, and then solve for the other physics interfaces in the subsequent steps. (If the flow is not affected at all by the current distribution, solving for the flow can be disabled entirely in consecutive steps).

- 
- [Electrochemistry Interfaces](#)

In the *COMSOL Multiphysics Reference Manual*:



- [Studies and Solvers](#)
  - [Analyzing Model Convergence and Accuracy](#)
  - [Achieving Convergence When Solving Nonlinear Equations](#)
-

## *Time-Dependent Problems with Load Steps*

---

For time-dependent problems, try the following to mitigate accuracy and convergence issues with regards to sudden current or potential load steps.

- Use smoothed current or potential load functions in order to avoid discrete load steps.
- Add a double layer capacitance to the model, which can improve the numerical stability.
- Under **Time Stepping** in the time-dependent solver node, reduce the **Maximum step** if you want to prevent the solver from “missing” short load pulses, or change the **Steps taken by solver** setting from **Free** to **Strict** or **Intermediate**, to control the time steps using the **Times** text field. Using the **Events** interface can also be an option for pulse simulations (or if the load cycle itself varies dynamically).



- [Double-Layer Capacitance](#)

In the *COMSOL Multiphysics Reference Manual*:

- [Step and Time Dependent](#)
  - [Building a COMSOL Multiphysics Model and The Events Interface](#)
- 

## *Solver Settings*

---

Try adjusting the solver settings.

- In rare cases, try to increase the **Maximum number of iterations** (on the **Fully Coupled**, **Segregated**, or **Iterative node**).
- If you know the order of magnitude of the dependent variables beforehand, setting the scaling method to **Manual** for these can improve convergence and the accuracy of the results. For concentration variables, setting the scaling to Initial Value Based can often be a good strategy. The scaling settings are found on the **Dependent**

**Variables** nodes in the study sequence, and on the individual variable subnodes to this node.



In the *COMSOL Multiphysics Reference Manual*:

- [Studies and Solvers](#)
  - [Analyzing Model Convergence and Accuracy](#)
  - [Achieving Convergence When Solving Nonlinear Equations](#)
-



# Chemical Species Transport Interfaces

This chapter describes the physics interfaces found under the **Chemical Species Transport** branch (🧪). The chapter summarizes each physics interface including the different fields, material properties, and boundary conditions associated with them, and suggests how and when to apply it.

In this chapter:

- [The Transport of Diluted Species Interface](#)
- [The Chemistry Interface](#)
- [The Nernst–Planck–Poisson Equations Interface](#)
- [The Electrophoretic Transport Interface](#)
- [The Surface Reactions Interface](#)
- [Theory for the Transport of Diluted Species Interface](#)
- [Theory for the Electrophoretic Transport Interface](#)
- [Theory for the Surface Reactions Interface](#)
- [Theory for the Coupling of Mass Transport to Electrochemical Reactions](#)

# The Transport of Diluted Species Interface

The **Transport of Diluted Species (tds)** interface () , found under the **Chemical Species Transport** branch () , is used to calculate the concentration field of a dilute solute in a solvent. Transport and reactions of the species dissolved in a gas, liquid, or solid can be handled with this interface. The driving forces for transport can be diffusion by Fick's law, convection when coupled to a flow field, and migration, when coupled to an electric field.

The interface supports simulation of transport by convection and diffusion in 1D, 2D, and 3D as well as for axisymmetric components in 1D and 2D. The dependent variable is the molar concentration,  $c$ . Modeling multiple species transport is possible, whereby the physics interface solves for the molar concentration,  $c_i$ , of each species  $i$ .

## SETTINGS

The **Label** is the default physics interface name.

The **Name** is used primarily as a scope prefix for variables defined by the physics interface. Refer to such physics interface variables in expressions using the pattern `<name>.<variable_name>`. In order to distinguish between variables belonging to different physics interfaces, the `name` string must be unique. Only letters, numbers, and underscores (`_`) are permitted in the **Name** field. The first character must be a letter.

The default **Name** (for the first physics interface in the model) is `tds`.

## DOMAIN SELECTION

If any part of the model geometry should not partake in the mass transfer model, remove that part from the selection list.

## OUT-OF-PLANE THICKNESS

For 2D components, the **Thickness** field (default value: 1 m) defines a parameter for the thickness of the geometry perpendicular to the two-dimensional cross-section. Both constant and varying thicknesses are supported. The value of this parameter is used, among other things, to automatically calculate molar flow rates from the total molar flux.

### CROSS-SECTIONAL AREA

For 1D components, enter a **Cross-sectional area**  $A_c$  (SI unit:  $\text{m}^2$ ) to define a parameter for the area of the geometry perpendicular to the 1D component. Both constant and varying areas are supported. The value of this parameter is used, among other things, to automatically calculate molar flow rates from the total molar flux. The default is  $1 \text{ m}^2$ .

### TRANSPORT MECHANISMS

Mass transport due to diffusion is always included. Use the checkboxes available under **Additional transport mechanisms** to control other transport mechanisms.

Note: Some of the additional transport mechanisms listed below are only available in certain products. For details see [www.comsol.com/products/specifications/](http://www.comsol.com/products/specifications/).

- By default, the **Convection** checkbox is selected. Clear the checkbox to disable convective transport.
- Select the **Migration in electric field** checkbox to activate transport of ionic species in an electric field. See further the theory section [Adding Transport Through Migration](#).



Transport of ionic species in an electric field is available in a limited set of add-on products. See [www.comsol.com/products/specifications/](http://www.comsol.com/products/specifications/) for more details on availability.

---

### *Mass Transport in Porous Media*

The **Mass transport in porous media** checkbox activates functionality specific to species transport in porous media:

- [Porous Medium](#)
- [Unsaturated Porous Medium](#)
- [Porous Electrode Coupling](#)
- [Volatilization](#)
- [Species Source](#)



Note: Mass transport in porous media is only available in a limited set of add-on products. See [www.comsol.com/products/specifications/](http://www.comsol.com/products/specifications/) for more details on availability.

---

## CONSISTENT STABILIZATION

To display this section, click the **Show** button (  ) and select **Stabilization**.

- When the **Crosswind diffusion** checkbox is selected, a weak term that reduces spurious oscillations is added to the transport equation. The resulting equation system is always nonlinear. There are two options for the **Crosswind diffusion type**:
  - **Do Carmo and Galeão** — the default option. This type of crosswind diffusion reduces undershoots and overshoots to a minimum but can in rare cases give equation systems that are difficult to fully converge.
  - **Codina** — this option is less diffusive compared to the Do Carmo and Galeão option but can result in more undershoots and overshoots. It is also less effective for anisotropic meshes. The Codina option activates a text field for the **Lower gradient limit**  $g_{lim}$ . Its default is  $0.1 [mol/m^3] / tds.hElem$ , where  $tds.hElem$  is the local element size.
- For both consistent stabilization methods, select an **Equation residual**. **Approximate residual** is the default and means that derivatives of the diffusion tensor components are neglected. This setting is usually accurate enough and is computationally faster. If required, select **Full residual** instead.

## INCONSISTENT STABILIZATION

To display this section, click the **Show** button (  ) and select **Stabilization**. By default, the **Isotropic diffusion** checkbox is not selected, because this type of stabilization adds artificial diffusion and affects the accuracy of the original problem. However, this option can be used to get a good initial guess for under resolved problems.

## ADVANCED SETTINGS

To display this section, click the **Show** button (  ) and select **Advanced Physics Options**. Normally these settings do not need to be changed. Select a **Material Balance Form** — **Nonconservative** (the default) or **Conservative**. The conservative formulation should be used for compressible flow. See [Material Balance Formulation](#) for more information.

## DISCRETIZATION

To display all settings available in this section, click the **Show** button (  ) and select **Advanced Physics Options**.

The **Compute boundary fluxes** checkbox is activated by default so that COMSOL Multiphysics computes predefined accurate boundary flux variables. When this option is selected, the solver computes variables storing accurate boundary fluxes from each boundary into the adjacent domain.

If the checkbox is cleared, the COMSOL Multiphysics software instead computes the flux variables from the dependent variables using extrapolation, which is less accurate in postprocessing results but does not create extra dependent variables on the boundaries for the fluxes.

The flux variables affected in the interface are:

- $\text{ndflux}_c$  (where  $c$  is the dependent variable for the concentration). This is the normal diffusive flux and corresponds to the boundary flux when diffusion is the only contribution to the flux term.
- $\text{ntflux}_c$  (where  $c$  is the dependent variable for the concentration). This is the normal total flux and corresponds to the boundary flux plus additional transport terms, for example, the convective flux when you use the nonconservative form.

Also the **Apply smoothing to boundary fluxes** checkbox is available if the previous checkbox is selected. The smoothing can provide a more well-behaved flux value close to singularities.



For details about the boundary fluxes settings, see [Computing Accurate Fluxes](#) in the *COMSOL Multiphysics Reference Manual*.

The **Value type when using splitting of complex variables** setting should in most pure mass transfer problems be set to **Real**, which is the default. It makes sure that the dependent variable does not get affected by small imaginary contributions, which can occur, for example, when combining a Time Dependent or Stationary study with a frequency-domain study. For more information, see [Splitting Complex-Valued Variables](#) in the *COMSOL Multiphysics Reference Manual*.

## DEPENDENT VARIABLES



The dependent variable name is the **Concentration  $c$**  by default. The names must be unique with respect to all other dependent variables in the component.

Add or remove species variables in the model and also change the names of the dependent variables that represent the species concentrations.

Enter the **Number of species**. Use the **Add concentration** (  ) and **Remove concentration** (  ) buttons as needed.

## FURTHER READING



---

	<ul style="list-style-type: none"><li>• <a href="#">Theory for the Transport of Diluted Species Interface</a></li><li>• <a href="#">Numerical Stabilization</a> in the <i>COMSOL Multiphysics Reference Manual</i>.</li><li>• In the <i>COMSOL Multiphysics Reference Manual</i>, see <a href="#">Table 2-4</a> for links to common sections and <a href="#">Table 2-5</a> for common feature nodes. You can also search for information: press F1 to open the <b>Help</b> window or Ctrl+F1 to open the <b>Documentation</b> window.</li></ul>
	<ul style="list-style-type: none"><li>• <i>Effective Diffusivity in Porous Materials</i>: Application Library path <b>COMSOL_Multiphysics/Diffusion/effective_diffusivity</b></li><li>• <i>Micromixer</i>: Application Library path <b>COMSOL_Multiphysics/Fluid_Dynamics/micromixer</b></li></ul>

---

### *The Transport of Diluted Species in Porous Media Interface*

---

This interface () , found under the **Chemical Species Transport** branch () , is used to calculate the species concentration and transport in free and porous media. The interface is the same as the *Transport of Diluted Species* interface but it uses other defaults: The [Mass Transport in Porous Media](#) property is selected, and a [Porous Medium](#) node is added by default. The interface includes reaction rate expressions and solute sources for modeling of species transport and reaction in porous media.

This interface is dedicated to modeling transport in porous media, including immobile and mobile phases, where the chemical species may be subjected to diffusion, convection, migration, dispersion, adsorption, and volatilization in porous media. It supports cases where either the solid phase substrate is exclusively immobile, or when a gas-filling medium is also assumed to be immobile.

It applies to one or more diluted species or solutes that move primarily within a fluid that fills (saturated) or partially fills (unsaturated) the voids in a solid porous medium. The pore space not filled with fluid contains an immobile gas phase. Models including a combination of porous media types can be studied.

The main feature nodes are the **Porous Medium** and **Unsaturated Porous Medium** nodes, which add the equations for the species concentrations and provide an interface for defining the properties of the porous media, as well as additional properties governing

adsorption, volatilization, dispersion and diffusion, migration, and the velocity field to model convection.

The physics interface can be used for stationary and time-dependent analysis.



When this physics interface is added, these default nodes are also added to the **Model Builder** — **Porous Medium, No Flux** (the default boundary condition), and **Initial Values**. Then, from the **Physics** toolbar, add other nodes that implement, for example, boundary conditions, reaction rate expressions, and species sources. You can also right-click **Transport of Diluted Species in Porous Media** to select physics features from the context menu.

## SETTINGS

The rest of the settings are the same as [The Transport of Diluted Species Interface](#).

## FURTHER READING

---

	<ul style="list-style-type: none"><li>• <a href="#">Mass Balance Equation for Transport of Diluted Species in Porous Media</a></li><li>• <a href="#">Domain, Boundary, and Pair Nodes for the Transport of Diluted Species Interface</a></li></ul>
	<ul style="list-style-type: none"><li>• <i>Variably Saturated Flow and Transport — Sorbing Solute:</i> Application Library path <b>Subsurface_Flow_Module/Solute_Transport/sorbing_solute</b> Web link: <a href="http://www.comsol.com/model/variably-saturated-flow-and-transport-sorbing-solute-490">www.comsol.com/model/variably-saturated-flow-and-transport-sorbing-solute-490</a></li></ul>

---

### *Domain, Boundary, and Pair Nodes for the Transport of Diluted Species Interface*

---

[The Transport of Diluted Species Interface](#) has the following domain, boundary, point, and pair nodes, listed in alphabetical order, available from the **Physics** ribbon toolbar

(Windows users), **Physics** context menu (Mac or Linux users), or by right-clicking to access the context menu (all users).



- To add a node, go to the **Physics** toolbar, no matter what operating system you are using.
- Contextual subnodes (attributes) are available by clicking the parent node in the Model Builder, and then selecting the subnode from the **Attributes** menu.

- Adsorption
- Concentration
- Continuity on Interior Boundaries
- Dispersion
- Electrode Surface Coupling
- Equilibrium Reaction
- Fast Irreversible Surface Reaction
- Fluid
- Fluid (Porous Medium)
- Flux
- Flux Discontinuity
- Fracture
- Gas
- Inflow
- Initial Values
- Line Mass Source
- Liquid
- Mass-Based Concentrations
- No Flux
- Open Boundary
- Out-of-Plane Flux
- Outflow
- Partition Condition
- Periodic Condition
- Point Mass Source
- Porous Matrix
- Porous Medium
- Porous Electrode Coupling
- Reaction Coefficients
- Reactions
- Solid
- Species Properties
- Species Source
- Surface Reactions
- Surface Equilibrium Reaction
- Symmetry
- Thin Diffusion Barrier
- Thin Impermeable Barrier
- Unsaturated Porous Medium
- Volatilization

Some features require certain add-on modules. For details see [www.comsol.com/products/specifications/](http://www.comsol.com/products/specifications/)



For axisymmetric components, COMSOL Multiphysics takes the axial symmetry boundaries (at  $r = 0$ ) into account and automatically adds an **Axial Symmetry** node that is valid on boundaries representing the symmetry axis.



In the *COMSOL Multiphysics Reference Manual*, see [Table 2-4](#) for links to common sections and [Table 2-5](#) for common feature nodes. You can also search for information: press F1 to open the **Help** window or Ctrl+F1 to open the **Documentation** window.

### *Prescribing Conditions on Fluid–Solid Interfaces*

Defining conditions on interfaces between different phases, typically a wall in contact with a fluid, it is worthwhile to be careful with how variables in the conditions are evaluated. COMSOL Multiphysics supports that variables are defined differently on adjacent domains (or any other geometry dimension). Evaluating a variable with differing definitions, the mean value is returned on a boundary separating the different domains. The density, pressure, or temperature are examples of variables that may differ in a fluid and a solid. In order to specify on which side a variable is evaluated, the [up and down](#) operators (described in the *COMSOL Multiphysics Reference Manual*) can be used.

### *Species Properties*

Use this node to define parameters specific to each of the species. It is available when the **Migration in electric field** checkbox is selected in the [Transport Mechanisms](#) section of the interface.

The node will change its label depending on what inputs are available in the node. If only **Charge** is available, it will be labeled “Species charges”.

#### **CHARGE**

Enter the charge number  $z_c$  (dimensionless, but requires a plus or minus sign) for each species.

#### **ACTIVITY**

This section is available when the **Species Activity** combo box is set to **Debye–Hückel** or **User defined**.

If **Debye–Hückel** is selected, enter the ion size number,  $a_0$ , for each species. If **User defined** is selected, enter the activity coefficient,  $f$ , for each species.

## *Fluid*

---

The settings in this node are dependent on the checkboxes selected under **Transport Mechanisms** in the **Settings** window for the Transport of Diluted Species interface. It includes only the sections required by the activated transport mechanisms. It has all the equations defining transport of diluted species as well as inputs for the material properties.

### **MODEL INPUTS**

The temperature model input is always available. Select the source of the **Temperature**. For **User defined**, enter a value or expression for the temperature in the input field. This input option is always available.

You can also select the temperature solved for by a Heat Transfer interface added to the model component. These physics interfaces are available for selection in the **Temperature** list.

### **CONVECTION**

If transport by convection is active, the velocity field of the solvent needs to be specified. Select the source of the **Velocity field**. For **User defined**, enter values or expressions for the velocity components in the input fields. This input option is always available.

You can also select the velocity field solved for by a Fluid Flow interface added to the model component. These physics interfaces are available for selection in the **Velocity field** list.

### **DIFFUSION**

Use this section to specify diffusion coefficients describing the diffusion of each species in the solvent fluid.

Use the **Source** list to select diffusion coefficients defined in a material or a Chemistry interface.

Select **Material** to use a diffusion coefficient in a material available in the model. User-defined property groups including a diffusion coefficient output property are available for selection in the **Fluid diffusion coefficient** list.

Select **Chemistry** to use a diffusion coefficient from a Chemistry interface added to model component. Diffusion coefficients are automatically defined when **Calculate transport properties** is selected on the interface level of a Chemistry interface. All defined diffusion coefficients are available for selection in the **Fluid diffusion coefficient** list.

For **User defined**, enter a value or expression for the **Fluid diffusion coefficient**  $D_c$  of each species in the corresponding input field. This can be a scalar value for isotropic diffusion or a tensor describing anisotropic diffusion. Select the appropriate tensor type — **Isotropic**, **Diagonal**, **Symmetric**, or **Full** that describes the diffusion transport, and then enter the values in the corresponding element (one value for each species).

Note that multiple species, as well as Migration in Electric fields (described below) is only available for certain COMSOL Multiphysics add-on products. See details: [www.comsol.com/products/specifications/](http://www.comsol.com/products/specifications/).

#### MIGRATION IN ELECTRIC FIELD

This section is available when the **Migration in electric field** checkbox is selected. From the **Electric potential** list, select the source of the electric field.

- Enter a value or expression for the **Electric potential**  $V$ , which is **User defined**; this input option is always available.
- Select the electric potential solved by an AC/DC-based interface that has also been added to the model.
- Select the electric potential defined or solved by Electrochemistry interface that has been added to the component.

By default the **Mobility** is set to be calculated based on the species diffusivity and the temperature using the **Nernst–Einstein relation**. For **User defined**, and under **Mobility**, select the appropriate scalar or tensor type — **Isotropic**, **Diagonal**, **Symmetric**, or **Full** — and type in the value of expression of the mobility  $u_{m,c}$ .

Enter the **Charge number**  $z_c$  (dimensionless, but requires a plus or minus sign) for each species.

The temperature (if you are using mobilities based on the Nernst–Einstein relation) is taken from **Model Inputs** section.

Note that the migration in electric fields feature is only available in some COMSOL products. See details: [www.comsol.com/products/specifications/](http://www.comsol.com/products/specifications/).

## EXAMPLE MODELS



- *Separation Through Dialysis*: Application Library path  
**Chemical\_Reaction\_Engineering\_Module/Mixing\_and\_Separation/dialysis**  
Web link: [www.comsol.com/model/separation-through-dialysis-258](http://www.comsol.com/model/separation-through-dialysis-258)



- *Transport in an Electrokinetic Valve*: Application Library path  
**Microfluidics\_Module/Fluid\_Flow/electrokinetic\_valve**  
Web link: [www.comsol.com/model/transport-in-an-electrokinetic-valve-603](http://www.comsol.com/model/transport-in-an-electrokinetic-valve-603)

### *Solid*

Use this node to describe diffusion in a solid phase domain. In this feature, the activities of the species are assumed to be ideal.

#### **DIFFUSION**

Specify the diffusion coefficients describing the diffusion of each species in the solid.

Enter a value or expression for the **Diffusion coefficient**  $D_c$  of each species in the corresponding input field. This can be a scalar value for isotropic diffusion or a tensor describing anisotropic diffusion. Select the appropriate tensor type — **Isotropic**, **Diagonal**, or **Symmetric** that describes the diffusion transport, and then enter the values in the corresponding element (one value for each species).

#### **ADVANCED**

This section is only available with the **Advanced Physics Options** selected and when the model contains a split between the material frame and the spatial frame. A split of these frames occurs when using a **Moving Mesh** node or a Structural Mechanics interface like **Solid Mechanics**. In such a model, the reference geometry (the material frame) differs from the deformed geometry (the spatial frame). The diffusive transport of species is solved for on the material frame, but the equation is adjusted for geometry deformations so that species conservation is achieved on the spatial frame. Use the **Diffusion model** to define the frame of reference for the diffusion tensor.

Select **Reference geometry based (Lagrangian)** to specify the diffusion tensor in the undeformed geometry, implying that the diffusion is defined in the material frame (indicated by coordinates  $X, Y, Z$ ). This is the preferred setting for an anisotropic

diffusion in combination with solid body translation or rotation. Also in general when the diffusion tensor components have been measured in an undeformed geometry.

Select **Deformed geometry based (Eulerian)** to specify the diffusion tensor in the deformed geometry. This means that the diffusion is defined in the spatial frame (indicated by coordinates  $x, y, z$ ). Use this setting when the diffusion tensor components have been measured in a deformed geometry.

The **Advanced Physics Options** is found in the **Show More Options** dialog, accessed by clicking the **Show More Options** button (  ).

Note that multiple species are only available for certain COMSOL Multiphysics add-on products. See details: [www.comsol.com/products/specifications/](http://www.comsol.com/products/specifications/).

### *Initial Values*

---

The **Initial Values** node specifies the initial values for the concentration of each species. These serve as an initial guess for a stationary solver or as initial conditions for a transient simulation.

#### **DOMAIN SELECTION**

If there are several types of domains with different initial values defined, it might be necessary to remove some domains from the selection. These are then defined in an additional **Initial Values** node.

#### **INITIAL VALUES**

Enter a value or expression for the initial value of the **Concentration** or concentrations,  $c_i$ . This also serves as a starting guess for stationary problems.

### *Mass-Based Concentrations*

---

Use the **Mass-Based Concentrations** node to add postprocessing variables for mass-based concentrations (SI unit:  $\text{kg}/\text{m}^3$ ) and mass fractions (dimensionless) for all species.

#### **MIXTURE PROPERTIES**

The default **Solvent density**  $\rho_{\text{solvent}}$  is taken **From material**. For **User defined**, enter a value or expression manually. Define the **Molar mass** of each species, which is needed to calculate the mass-based concentration.

## Reactions

---

Use the **Reactions** node to account for the consumption or production of species through chemical reactions. Define the rate expressions as required.

### DOMAIN SELECTION

From the **Selection** list, choose the domains on which to define rate expression or expressions that govern the source term in the transport equations.

Several reaction nodes can be used to account for different reactions in different parts for the modeling geometry.

### REACTION RATES

The **Chemistry** list shows all the Chemistry interfaces that are coupled to the current mass transport interface. The coupling conditions for the Chemistry interfaces are:

- Active
- **Define variables for porous pellets** (under the **Pellet Chemistry** section) is cleared
- **Species solved for** (under the **Species Matching** section) set to the current mass transport interface

The reaction rates can be taken from a coupled Chemistry interface automatically or by specifying a rate expression  $R_i$  (SI unit: mol/(m<sup>3</sup>·s)) for species  $i$ :

- With a **Chemistry** interface selected, the species mass sources will be set to the corresponding reaction rates in the **Chemistry** according to the **Species Matching** table. In the case of partial coupling, the mass sources for the uncoupled species will be set to 0.
- **User defined.** Enter a value or expression in the field. Note that if you have the *Chemistry* interface available, provided with the *Chemical Reaction Engineering Module*, the reaction rate expressions can be generated automatically and picked up from the lists. For an example, see the application *Fine Chemical Production in a Plate Reactor* as linked below.

### REACTING VOLUME

This section is only available when the [Mass Transport in Porous Media](#) property is available and selected. See [www.comsol.com/products/specifications/](http://www.comsol.com/products/specifications/) for more details on availability.

When specifying reaction rates for a species in porous media, the specified reaction rate may have the basis of the total volume, the pore volume, or in the case of using the

volume of a particular phase (applicable when modeling an unsaturated porous medium).

- For **Total volume**, the reaction expressions, in  $\text{mol}/(\text{m}^3 \cdot \text{s})$ , are specified per unit volume of the model domain (multiplied by unity).
- For **Pore volume**, the reaction expressions, in  $\text{mol}/(\text{m}^3 \cdot \text{s})$ , are specified per unit volume of total pore space. The reaction expressions will be multiplied by the domain porosity,  $\epsilon_p$ . ( $\epsilon_p$  equals unity for nonporous domains).
- For **Liquid phase**, the reaction expressions, in  $\text{mol}/(\text{m}^3 \cdot \text{s})$ , are specified per unit volume of liquid in the pore space. The expressions will be multiplied by the liquid volume fraction  $\theta_l$ . ( $\theta_l$  equals the porosity ( $\epsilon_p$ ) on Porous Medium domains).
- For **Gas phase**, the reaction expressions, in  $\text{mol}/(\text{m}^3 \cdot \text{s})$ , are multiplied by the gas volume fraction  $\theta_g = \epsilon_p - \theta_l$ .  $\theta_g$  equals 0 for Porous Medium domains.

### HEAT SOURCE

The heat source will be defined as reaction heat from whole Chemistry if the **Chemistry** list is set to a coupled chemistry interface, otherwise it is defined as the specified value (SI unit:  $\text{W}/\text{m}^3$ ).

### FURTHER READING

See the theory chapter on chemical species transport, starting with the section *Mass Balance Equation*.



- *Fine Chemical Production in a Plate Reactor*: Application Library path **Chemical\_Reaction\_Engineering\_Module/Reactors\_with\_Mass\_and\_Heat\_Transfer/plate\_reactor**  
Web link: [www.comsol.com/model/fine-chemical-production-in-a-plate-reactor-8589](http://www.comsol.com/model/fine-chemical-production-in-a-plate-reactor-8589)

### *No Flux*

This node is the default boundary condition on exterior boundaries. It should be used on boundaries across which there is no mass flux, typically solid walls where no surface reactions occur. The condition applied for each species corresponds to

$$-\mathbf{n} \cdot (-D\nabla c) = 0$$

where  $\mathbf{n}$  denotes the outward pointing normal of the boundary. When the mass transport includes migration of ionic species, the no flux condition is:

$$-\mathbf{n} \cdot (-D\nabla c - zu_m Fc\nabla\phi) = 0$$

### CONVECTION

By default, the feature prescribes a vanishing flux due to diffusion and migration in an electric field. This is the appropriate no flux condition when the relative convective velocity at the boundary is zero. When the fluid velocity at the boundary is not equal to that of the boundary, it is often convenient to prescribe the total flux including the convection. To do this select **Include** in the **Convection** section.

When including the convection, the no flux condition prescribed is

$$-\mathbf{n} \cdot (-D\nabla c + \mathbf{u}c) = 0$$

or

$$-\mathbf{n} \cdot (-D\nabla c - zu_m Fc\nabla\phi + \mathbf{u}c) = 0$$

when migration of ionic species is included.

### *Inflow*

---

Use this node to specify all species concentrations at an inlet boundary.

If you want to specify the concentration of a subset of the partaking species, this can be done by using the [Concentration](#) node instead.

For the **Electroanalysis** interface, this node is available when you select the **Convection** checkbox on the physics interface **Settings** window.

### CONCENTRATION

For the concentration of each species  $c_{0,c}$  (SI unit: mol/m<sup>3</sup>), enter a value or expression.

## BOUNDARY CONDITION TYPE

The option **Concentration constraint** constrains the concentration values on the boundary by the use of pointwise constraints.

The other option, **Flux (Danckwerts)** can be used when the concentration at the boundary is not known, or when it varies in a nontrivial manner. This may, for example, be useful when reactions with high reaction rates occur in the vicinity of the inlet. In this case the concentration far upstream of the boundary is instead prescribed. The **Flux (Danckwerts)** condition prescribes the total flux defined by the upstream concentration and the fluid velocity at the boundary.

## CONSTRAINT SETTINGS

To display this section, click the **Show More Options** button (  ) and select **Advanced Physics Options**. You can find details about the different constraint settings in the section [Constraint Reaction Terms](#) in the *COMSOL Multiphysics Reference Manual*.

## FURTHER READING

See the theory chapter in the section [Danckwerts Inflow Boundary Condition](#).

### *Outflow*

---

Apply this condition at outlets boundaries where species should be transported out of the model domain by fluid motion or by an electric field (in the case of ions). It is assumed that convection and migration (in an electric field) are the dominating transport mechanisms across the boundary, and therefore that the diffusive transport can be ignored, that is:

$$\mathbf{n} \cdot (-D\nabla c) = 0$$

Note that the **Convection** or the **Migration in electric field** transport mechanisms needs to be included for this node to be available.

### *Concentration*

---

This condition node adds a boundary condition for the species concentration. For example, a  $c = c_0$  condition specifies the concentration of species  $c$ .

## CONCENTRATION

Individually specify the concentration for each species. Select the checkbox for the **Species** to specify the concentration, and then enter a value or expression in the

corresponding field. To use another boundary condition for a specific species, click to clear the checkbox for the concentration of that species.

When defining conditions on boundaries between different phases, see the section [Prescribing Conditions on Fluid–Solid Interfaces](#).

### CONSTRAINT SETTINGS

To display this section, click the **Show** button (  ) and select **Advanced Physics Options**. You can find details about the different constraint settings in the section [Constraint Reaction Terms](#) in the *COMSOL Multiphysics Reference Manual*.

### *Flux*

---

This node can be used to specify the species molar flux across a boundary. The flux can for example occur due to chemical reactions or a phase change at the boundary. The flux can also represent the transport to or from a surrounding environment currently not included model.

The prescribed flux of a species  $c$  is by default defined as

$$-\mathbf{n} \cdot (-D\nabla c) = J_0$$

where  $\mathbf{n}$  denotes the outward pointing normal of the boundary. When the mass transport includes migration of ionic species, the flux is defined as

$$-\mathbf{n} \cdot (-D\nabla c - zu_m Fc\nabla\phi) = J_0$$

The flux prescribed,  $J_0$ , can include any arbitrary user-specified expression. It can be constant or a function of a dependent variable or independent variable. Common examples are a flux dependent of the concentration, temperature, pressure, or the electric potential  $\phi$ .

When defining conditions on boundaries between different phases, see the section [Prescribing Conditions on Fluid–Solid Interfaces](#).

### CONVECTION

By default, the flux due to diffusion and migration in an electric field is prescribed. This is the appropriate flux condition when the relative velocity at the boundary is zero. When the fluid velocity is not equal to that of the boundary, it is often convenient to prescribe the total flux, including the convection. To do this select **Include** in the **Convection** section.

When including the convection, the prescribed flux is defined as

$$-\mathbf{n} \cdot (-D\nabla c + \mathbf{u}c) = J_0$$

or

$$-\mathbf{n} \cdot (-D\nabla c - zu_m Fc \nabla \phi + \mathbf{u}c) = J_0$$

when migration of ionic species is included.

### INWARD FLUX

Select the Species checkbox for the species for which to specify the flux, and enter a value or expression for the inward flux in the corresponding field. Use a minus sign when specifying a flux directed out of the system. To use another boundary condition for a specific species, click to clear the checkbox for that species.

#### *External convection*

Set **Flux type** to **External convection** to prescribe a flux to or from an exterior domain (not modeled) assumed to include convection. The exterior can for example include a forced convection to control the temperature or to increase the mass transport. In this case the prescribed mass flux corresponds to

$$J_0 = k_c(c_b - c)$$

where  $k_c$  is a mass transfer coefficient and  $c_b$  is the bulk concentration, the typical concentration far into the surrounding exterior domain.

#### *Symmetry*

---

The **Symmetry** node can be used to represent boundaries where the species concentration is symmetric, that is, where there is no mass flux across the boundary.

This boundary condition is identical to that of the **No Flux** node.

#### *Flux Discontinuity*

---

This node represents a discontinuity in the mass flux across an interior boundary:

$$-\mathbf{n} \cdot [(\mathbf{J} + \mathbf{u}c)_u - (\mathbf{J} + \mathbf{u}c)_d] = N_0 \quad \mathbf{J} = -D\nabla c - zu_m Fc \nabla \phi$$

where the value  $N_0$  (SI unit: mol/(m<sup>2</sup>·s)) specifies the jump in total flux at the boundary. This can be used to model a boundary source, for example a surface reaction, adsorption, or desorption.

### FLUX DISCONTINUITY

In this section the jump in species flux (or surface source) is specified.

Select the Species checkbox for the species to specify and enter a value or expression for the material flux jump in the corresponding field. To use a different boundary condition for a specific species, click to clear the checkbox for the flux discontinuity of that species.

### *Partition Condition*

---

The **Partition Condition** node can be used to prescribe the relation between the concentration of a solute species in two adjoining immiscible phases. It can for example be used on interior boundaries separating two liquid phases, a gas-liquid interface, or on a boundary separating a liquid phase and a solid or porous media.

Select **Partition coefficient** from the **Relation** list to prescribe a linear relationship between the concentration on either side of a boundary. For a species concentration  $c_i$ , the ratio between the concentration on the upside and on the downside of the boundary ( $c_{i,u}$  and  $c_{i,d}$  respectively) is then defined in terms of a partition coefficient  $K_i$  in the manner of

$$K_i = \frac{c_{i,u}}{c_{i,d}}$$

Use the associated input field to prescribe the partition coefficient for each species.

Select **User defined** from the **Relation** list to set up a nonlinear relation between the up and downside concentrations. For such relations  $f(c_i)_u = f(c_i)_d$ , where  $f(c_i)_u$  is the expression enforced on the upside. Use the associated input fields to enter the upside and downside expressions for each species.

The up and downside of the selected boundary is indicated with a red arrow in the Graphics window. The arrow points from the downside into the upside. Select the **Reverse direction** checkbox to reverse the direction of the arrow on the selected

boundary, and update the definition of the up and downside concentrations accordingly.



This feature is only available in a limited set of add-on products. See [www.comsol.com/products/specifications/](http://www.comsol.com/products/specifications/) for more details on availability.

---

#### FURTHER READING

For an example of using a partition condition, see this application example:



*Separation Through Dialysis*: Application Library path  
**Chemical\_Reaction\_Engineering\_Module/Mixing\_and\_Separation/dialysis**

---

### *Periodic Condition*

The **Periodic Condition** node can be used to define periodicity for the mass transport between two sets of boundaries. The node prescribes continuity in the concentration and the mass flux between the “source” and the “destination” side, respectively. Note that these names are arbitrary and does not influence the direction in which mass is transported. It is dictated by mass transfer equations in the adjacent domains.

#### BOUNDARY SELECTION

The node can be activated on more than two boundaries, in which case the feature tries to identify two separate surfaces that each consist of one or several connected boundaries.

#### DESTINATION SELECTION

For more complex geometries, it might be necessary to specify the destination selection manually. To do so, right-click the **Periodic Condition** node and choose **Manual Destination Selection**. You can then specify the boundaries that constitute the destination surfaces in the **Destination Selection** section.

#### CONSTRAINT SETTINGS

To display this section, click the **Show More Options** button (  ) and select **Advanced Physics Options** in the **Show More Options** dialog. This section contains settings for specifying the type of constraint and whether to use a pointwise or weak constraint. See

[Constraint Settings](#) in the *COMSOL Multiphysics Reference Manual* for more information.

#### ORIENTATION OF SOURCE

To display this section, click the **Show More Options** button (  ) and select **Advanced Physics Options** in the **Show More Options** dialog. For information about the **Orientation of Source** section, see [Orientation of Source and Destination](#) in the *COMSOL Multiphysics Reference Manual*.

#### ORIENTATION OF DESTINATION

This section appears if the setting for **Transform to intermediate map** in the **Orientation of Source** section is changed from the default value, **Automatic**, and **Advanced Physics Options** is selected in the **Show More Options** dialog. For information about the **Orientation of Destination** section, see [Orientation of Source and Destination](#) in the *COMSOL Multiphysics Reference Manual*.

#### MAPPING BETWEEN SOURCE AND DESTINATION

To display this section, click the **Show More Options** button (  ) and select **Advanced Physics Options** in the **Show More Options** dialog. For information about the **Mapping Between Source and Destination** section, see [Mapping Between Source and Destination](#) in the *COMSOL Multiphysics Reference Manual*.

#### FURTHER READING

For an example of using a periodic condition, see this application example:



*The KdV Equation and Solitons*: Application Library path  
**COMSOL\_Multiphysics/Equation\_Based/kdv\_equation**

---

#### *Line Mass Source*

---

The **Line Mass Source** feature models mass flow originating from a tube or line region with an infinitely small radius.



This feature is only available in a limited set of add-on products. See [www.comsol.com/products/specifications/](http://www.comsol.com/products/specifications/) for more details on availability.

---

## SELECTION

The **Line Mass Source** feature is available for all dimensions, but the applicable selection differs between the dimensions.

MODEL DIMENSION	APPLICABLE GEOMETRICAL ENTITY
2D	Points
2D Axisymmetry	Points not on the symmetry axis and the symmetry axis
3D	Edges

## SPECIES SOURCE

Enter the source strength,  $\dot{q}_{l,c}$ , for each species (SI unit: mol/(m·s)). A positive value results in species injection from the line into the computational domain, and a negative value means that the species is removed from the computational domain.

Line sources located on a boundary affect the adjacent computational domains. This effect makes the physical strength of a line source located in a symmetry plane twice the given strength.

## FURTHER READING

See the section [Mass Sources for Species Transport](#).

### *Point Mass Source*

The **Point Mass Source** feature models mass flow originating from an infinitely small domain around a point.



This feature is only available in a limited set of add-on products. See [www.comsol.com/products/specifications/](http://www.comsol.com/products/specifications/) for more details on availability.

## SPECIES SOURCE

Enter the source strength,  $\dot{q}_{p,c}$ , for each species (SI unit: mol/s). A positive value results in species injection from the point into the computational domain, and a negative value means that the species is removed from the computational domain.

Point sources located on a boundary or on an edge affect the adjacent computational domains. This has the effect, for example, that the physical strength of a point source located in a symmetry plane is twice the given strength.

## FURTHER READING

See the section [Mass Sources for Species Transport](#).

### *Open Boundary*

---

Use this node to set up mass transport across boundaries where both convective inflow and outflow can occur. On the parts of the boundary where fluid flows into the domain, an exterior species concentration is prescribed. On the remaining parts, where fluid flows out of the domain, a condition equivalent to the **Outflow** node is instead prescribed.

The direction of the flow across the boundary is typically calculated by a fluid flow interface and is provided as a model input to the Transport of Diluted Species interface.



This feature is only available in a limited set of add-on products. See [www.comsol.com/products/specifications/](http://www.comsol.com/products/specifications/) for more details on availability.

## EXTERIOR CONCENTRATION

Enter a value or expression for the **Exterior concentration**.

### *Thin Diffusion Barrier*

---

Use this boundary condition to model a thin layer through which mass is transported by diffusion only. The node is applicable on interior boundaries and can be used to avoid meshing thin structures.

#### THIN DIFFUSION BARRIER

Specify the **Layer thickness**,  $d_s$ , and input a **Diffusion coefficient**,  $D_{s,c}$ , for each of the species included.

### *Thin Impermeable Barrier*

---

This feature models a thin mass transfer barrier. It is available on interior boundaries and introduces a discontinuity in the concentration across the boundary. On each side, a no-flux condition is prescribed for the mass transport implying that it acts as a barrier. The feature can be used to avoid meshing thin structures.

Solving a model involving coupled fluid flow and mass transfer, the Thin Impermeable Barrier feature can be combined with an Interior Wall feature in order to model a thin solid wall.

### *Equilibrium Reaction*

---

Use this node to model a reaction where the kinetics is so fast that the equilibrium condition is fulfilled at all times. The node solves for an additional degree of freedom (the reaction rate  $R_{\text{eq}}$ ) to fulfill the equilibrium condition at all times in all space coordinates.

If the **Apply equilibrium condition on inflow boundaries** checkbox is selected, the specified inflow concentration values in all active **Inflow** boundary nodes for the physics interface are modified to comply with the equilibrium condition.



- A necessary requirement for this feature to be available is that two or more species are solved for by the interface.
- This feature is only available in a limited set of add-on products. See [www.comsol.com/products/specifications/](http://www.comsol.com/products/specifications/) for more details on availability.

---

#### **EQUILIBRIUM CONDITION**

The **Chemistry** list shows two ways to define an equilibrium reaction.

- **A coupled chemistry** — The **Equilibrium reaction formula** is available when the **Chemistry** list is set to a coupled chemistry interface. All the equilibrium reaction formulas in the coupled chemistry will appear in the formula list. Select one of them, then all coefficients (stoichiometric coefficients, equilibrium constant) will be taken from the coupled reaction automatically. There would be no any source term contributions if the **Equilibrium reaction formula** list is set to **None**.
- **None** — If **None** is selected from the **Chemistry** list, an equilibrium reaction will be defined by settings from fields of **Equilibrium definition**, **Equilibrium constant**, and **Unit activity concentration**.

The default value for **Equilibrium definition** list is **Equilibrium constant** or select **User defined**. For either option, the **Apply equilibrium condition on inflow boundaries** checkbox is selected by default.

For **Equilibrium constant**, enter an **Equilibrium constant**  $K_{\text{eq}}$  (dimensionless). Also enter a value or expression for the **Unit activity concentration**  $C_{a0}$  (SI unit: mol/m<sup>3</sup>).

Selecting **Equilibrium constant** defines an equilibrium condition based on the stoichiometric coefficients, the species activities, and the law of mass action.

For **User defined**, enter an **Equilibrium expression**  $E_{\text{eq}}$  (dimensionless).

### STOICHIOMETRIC COEFFICIENTS

This section is available when the **Chemistry** list is set to **None**.

Enter a value for the stoichiometric coefficient  $\nu_c$  (dimensionless). The default is 0. Use negative values for reactants and positive values for products in the modeled reaction.

Species with a stoichiometric coefficient value of 0 are not affected by the **Equilibrium Reaction** node.

### HEAT SOURCE

The heat source will be defined from reaction heat from this equilibrium reaction.

- An equilibrium reaction defined from a **Chemistry** (from the **Equilibrium reaction formula** list). The heat source is defined as the same as that of equilibrium reaction in Chemistry.
- **None** selected in the **Chemistry** list. Enter a value or expression for the heat source (SI unit: W/m<sup>3</sup>).

### FURTHER READING

See

- [Equilibrium Reaction Theory](#)
- [Theory for the Coupling of Mass Transport to Electrochemical Reactions](#)

### *Surface Reactions*

---

The **Surface Reactions** node can be used to account for the species boundary flux due to chemical reactions occurring on a surface (heterogeneous reactions). For a domain species participating in a surface reaction, the boundary flux corresponds to the reaction rate at the surface.

### SURFACE REACTION RATE

Specify the surface reaction rate  $J_0$  of each species resulting from the reactions. Note that if you have the Chemistry interface available, provided with the Chemical

Reaction Engineering Module, the reaction rate expressions can be automatically generated and picked up from the lists.

When defining conditions on boundaries between different phases, see the section [Prescribing Conditions on Fluid–Solid Interfaces](#).

#### FURTHER READING

For an example of using the Surface Reactions node, see this application example:



*Chemical Vapor Deposition of GaAs*: Application Library path  
**Chemical\_Reaction\_Engineering\_Module/  
Reactors\_with\_Mass\_and\_Heat\_Transfer/gaas\_cvd**

---

#### *Surface Equilibrium Reaction*

---

Use this node to model an equilibrium reaction on a boundary (surface). The settings for this node are similar to [Equilibrium Reaction](#). Note that a necessary requirement for this is feature to be available is that two or more species are solved for by the interface.

When defining conditions on boundaries between different phases, see the section [Prescribing Conditions on Fluid–Solid Interfaces](#).



This feature is only available in a limited set of add-on products. See [www.comsol.com/products/specifications/](http://www.comsol.com/products/specifications/) for more details on availability.

---

#### *Fast Irreversible Surface Reaction*

---

This boundary node defines an irreversible reaction where the kinetics is so fast that the only factor limiting the reaction rate is the transport of a species to the reacting surface.

The node will set the **Rate limiting species concentration to zero** at the boundary, and balance the fluxes of the species participating in the reaction and the current densities according to the Stoichiometric Coefficients settings.

When defining conditions on boundaries between different phases, see the section [Prescribing Conditions on Fluid–Solid Interfaces](#).



This feature is only available in a limited set of add-on products. See [www.comsol.com/products/specifications/](http://www.comsol.com/products/specifications/) for more details on availability.

---

### *Porous Electrode Coupling*

---

Use this node to add a molar source in a domain that is coupled to one or multiple [Porous Electrode Reaction](#) nodes of an Electrochemistry Interface.

The molar source is calculated from the number of electrons, stoichiometric coefficients, and volumetric current densities of the coupled porous electrode reactions specified in the **Reaction Coefficients** subnodes.

In the Transport of Concentrated Species interface, the molar sources (or sinks) are multiplied by the species molar masses to obtain the corresponding mass sources.

Additional [Reaction Coefficients](#) subnodes are available from the context menu (right-click the parent node) as well as from the **Physics** toolbar, **Attributes** menu.

Note that if you are also modeling the momentum transport and expect a nonnegligible total mass source or sink, which is often the case in gas diffusion electrodes, you need to also add a corresponding mass source/sink in the Fluid Flow interface. (A **Reacting Flow** multiphysics node adds the associated source/sink term in a Fluid Flow interface automatically.)



This feature is only available in a limited set of add-on products. See [www.comsol.com/products/specifications/](http://www.comsol.com/products/specifications/) for more details on availability.

---

### *Reaction Coefficients*

---

Add this node to the [Electrode Surface Coupling](#) and [Porous Electrode Coupling](#) features to define molar fluxes and sources based on electrode current densities in an **Electrochemistry** interface.

The molar flux or source is proportional to the stoichiometric coefficients and the current density according to Faraday's law.

Current densities from **Electrode Reaction** ( $i_{loc}$ , SI unit: A/m<sup>2</sup>) or **Porous Electrode Reaction** nodes ( $i_v$ , SI unit: A/m<sup>3</sup>) of any **Electrochemistry** interface in the model are available for selection as the **Coupled reaction**, and user-defined expressions are also supported.

Enter the **Number of participating electrons**  $n_m$  (dimensionless) and the **Stoichiometric coefficient**  $v_c$  (dimensionless) as explained in the theory section linked below.

Use multiple subnodes to couple to multiple reactions.



## Theory for the Coupling of Mass Transport to Electrochemical Reactions

---

### *Electrode Surface Coupling*

---

Use this node to define a flux boundary condition based on current densities of one or multiple **Electrode Reaction** nodes in an Electrochemistry interface.

The flux is proportional to the current densities and the stoichiometric coefficients according to Faraday's law as defined by summation over the **Reaction Coefficients** subnodes.

Note that if you are also modeling the momentum transport and expect a nonnegligible total mass flux over the boundary, which is often the case for gas diffusion electrodes, you need to also add a corresponding Electrode Surface Coupling node in the Fluid Flow interface.



This feature is only available in a limited set of add-on products. See [www.comsol.com/products/specifications/](http://www.comsol.com/products/specifications/) for more details on availability.

---

### *Porous Medium*

---

Use this node to model the concentration of diluted species transported by a solvent (mobile fluid phase) through interstices in a solid porous medium. In addition to

transport due to convection and diffusion, the node contains functionality to include species evolution through adsorption and dispersion.



This feature is only available in a limited set of add-on products. See [www.comsol.com/products/specifications/](http://www.comsol.com/products/specifications/) for more details on availability.

Species transport through a porous medium is affected both by properties of the fluid phase, and as well as properties of the solid matrix. These properties are defined in the [Fluid \(Porous Medium\)](#) and [Porous Matrix](#) subnodes respectively. The Porous Medium node supports material properties using a [Porous Material](#) node (described in the *COMSOL Multiphysics Reference Manual*), where properties are defined per phase in a similar manner.

Add an [Adsorption](#) or a [Dispersion](#) subfeature to the **Porous Medium** to account for the corresponding transport mechanism.

### *Fluid (Porous Medium)*

Use this node to specify the mass transfer in the mobile fluid solvent filling the pores of a porous medium. It is used as a subnode to [Porous Medium](#).

#### **MODEL INPUTS**

The temperature model input is always available. By default, the **Temperature** model input is set to **Common model input**, and the temperature is controlled from [Default Model Inputs](#) under **Global Definitions** or by a locally defined [Model Input](#). If a Heat Transfer interface is included in the component, it controls the temperature **Common model input**. Alternatively, the temperature field can be selected from another physics interface. All physics interfaces have their own tags (**Name**). For example, if a Heat Transfer in Fluids interface is included in the component, the **Temperature (ht)** option is available for  $T$ .

You can also select **User defined** from the **Temperature** model input in order to manually prescribe  $T$ .

#### **CONVECTION**

If transport by convection is active, the velocity field of the solvent needs to be specified. For **User defined**, enter values or expressions for the velocity components in the input fields. This input option is always available. You can also select the velocity

field solved for by a Fluid Flow interface added to the model component. These physics interfaces are available for selection in the **Velocity field** list.

## **DIFFUSION**

Use this section to specify diffusion coefficients describing the diffusion of each species in the solvent fluid.

Use the **Source** list to select to pick up diffusion coefficients defined in a material or a Chemistry interface.

Select **Material**, and a **Fluid material** to use a diffusion coefficient in a material available in the model. User-defined property groups including a diffusion coefficient output property are available for selection in the **Fluid diffusion coefficient** list.

Select **Chemistry** to use a diffusion coefficient from a Chemistry interface added to model component. Diffusion coefficients are automatically defined when **Calculate transport properties** is selected on the interface level of a Chemistry interface. All defined diffusion coefficients are available for selection in the **Fluid diffusion coefficient** list.

For **User defined**, enter a value or expression for the **Fluid diffusion coefficient**  $D_{F,i}$  of each species in the corresponding input field.

In a porous medium the diffusivity is reduced due to the fact that the solid grains impede Brownian motion. Select an **Effective diffusivity model** to account for the reduced diffusivity. The available models are **Millington and Quirk model** (the default), **Bruggeman model**, **Tortuosity model**, or **No correction**. For **Tortuosity model**, enter a value for the tortuosity  $\tau_{F,i}$  (dimensionless).

Note that multiple species, as well as Migration in Electric fields (described below) is only available for certain COMSOL Multiphysics add-on products. For details, see [www.comsol.com/products/specifications/](http://www.comsol.com/products/specifications/).

## **MIGRATION IN ELECTRIC FIELD**

This section is available when the **Migration in electric field** checkbox is selected. From the **Electric potential** list, select the source of the electric field.

- For **User defined**, enter a value or expression for the **Electric potential**  $V$ . This input option is always available.

- Select the electric potential solved by an AC/DC-based interface that has added to the component.
- Select the electric potential defined or solved for by an Electrochemistry interface added to the component.

By default the **Mobility** is set to be calculated based on the species effective diffusivity and the temperature using the **Nernst–Einstein relation**. For **User defined**, select the appropriate scalar or tensor type — **Isotropic**, **Diagonal**, **Symmetric**, or **Full** — and type in the value or expression of the effective mobility  $u_{me,i}$ .

Enter the **Charge number**  $z_c$  for each species.

### *Porous Matrix*

---

This node sets the porosity when modeling transport of diluted species in a **Porous Medium** or an **Unsaturated Porous Medium**. The porosity corresponds to the volume fraction occupied by the species containing fluid.

- By default the porosity of the solid matrix,  $\epsilon_p$ , is taken **From material**. The **Porous Matrix** node supports the use of a **Porous Material** added to the Materials branch. In this case the porosity is defined in the manner of

$$\epsilon_p = 1 - \sum_i \theta_{s,i} - \sum_i \theta_{imf,i}$$

where  $\theta_{s,i}$  and  $\theta_{imf,i}$  are the volume fractions given in **Solid** and **Immobile Fluids** subnodes under the **Porous Material** node.

- Select **From pellet bed densities** to compute the porosity using the (dry bulk) **Bed density**  $\rho_b$  and the (single phase) **Pellet density**  $\rho_{pe}$ . The porosity is then defined from

$$\epsilon_p = 1 - \frac{\rho_b}{\rho_{pe}}$$

- For **User defined**, enter a value or expression for the porosity.

### *Dispersion*

---

Local variations in the velocity as the fluid flows around solid particles lead to mechanical mixing, referred to as dispersion. Use this feature to account for dispersion in a **Porous Medium** or a **Unsaturated Porous Medium**

This subfeature is available when both the **Mass transfer in porous media mass transfer** checkbox and the **Convection** checkbox are selected in the **Settings** window for the physics interface.

Select the **Specify dispersion for each species individually** checkbox to specify the dispersion tensor  $D_D$  (SI unit:  $m^2/s$ ) for each species separately. When not selected the same dispersion tensor  $D_D$  is used for all species.

Select an option from the **Dispersion tensor** list — **Dispersivity** or **User defined**.

Select **Dispersivity** to specify the dispersion in terms of dispersivities (SI unit: m). Select an option from the **Dispersivity model** list: **Isotropic** (the default) or **Transverse isotropic** based on the properties of the porous media. For isotropic porous media, specify the longitudinal and transverse dispersivities. For transverse isotropic porous media, specify the longitudinal, horizontal transverse, and vertical transverse dispersivities.

For **User defined**, specify the dispersion components in terms of constants or expressions. Select **Isotropic**, **Diagonal**, **Symmetric**, or **Full** to enable the appropriate tensor components.

### *Unsaturated Porous Medium*

---

Use this node to model the concentration of diluted species transported by a solvent (mobile fluid phase) through interstices in a solid porous medium. In addition to transport due to convection and diffusion, the node contains functionality to include species evolution through adsorption and dispersion.

Use this node to model the concentration of diluted species transported by a liquid (mobile fluid phase) in a partially filled solid porous medium. The interstices of the porous medium contains the liquid carrier phase and gas pockets. Apart from convection and diffusion, the node contains functionality to include species evolution through adsorption, dispersion, and volatilization.



This feature is only available in a limited set of add-on products. See [www.comsol.com/products/specifications/](http://www.comsol.com/products/specifications/) for more details on availability.

---

The properties of each phase present are defined using the **Liquid**, the **Gas**, and the **Porous Matrix** subnodes respectively. The Unsaturated Porous Medium node supports material properties using a **Porous Material** node (described in the *COMSOL*

*Multiphysics Reference Manual*), where properties are defined per phase in a similar manner.

Add an [Adsorption](#) or a [Dispersion](#) subfeature to the **Unsaturated Porous Medium** to account for the corresponding transport mechanism.

## *Liquid*

---

Use this node to specify the mass transfer in the mobile liquid solvent present in the pores of the [Unsaturated Porous Medium](#).

### **MODEL INPUTS**

The temperature model input is always available. By default, the **Temperature** model input is set to **Common model input**, and the temperature is controlled from [Default Model Inputs](#) under **Global Definitions** or by a locally defined [Model Input](#). If a Heat Transfer interface is included in the component, it controls the temperature **Common model input**. Alternatively, the temperature field can be selected from another physics interface. All physics interfaces have their own tags (**Name**). For example, if a Heat Transfer in Fluids interface is included in the component, the **Temperature (ht)** option is available for  $T$ .

You can also select **User defined** from the **Temperature** model input in order to manually prescribe  $T$ .

### **SATURATION**

Select **Saturation** or **Liquid volume fraction** from the list.

For **Saturation**, enter a value for  $s$  (dimensionless) between 0 and 1. The liquid volume fraction is then computed from the saturation and porosity as  $\theta_l = \varepsilon_p s$ .

For **Liquid volume fraction**, enter a value for  $\theta_l$  (dimensionless) between 0 and the value of the porosity.

Select a **Liquid fraction time change**: **Liquid fraction constant in time** (the default), **Time change in liquid fraction**, or **Time change in pressure head**.

- For **Time change in fluid fraction**, enter  $d\theta/dt$  (SI unit: 1/s).
- For **Time change in pressure head**, enter  $dH_p/dt$  (SI unit: m/s) and a **Specific moisture capacity**  $C_m$  (SI unit: 1/m). If a Darcy's Law interface is included in the component, the time change in pressure head solved for can be selected.

## CONVECTION

If transport by convection is active, the velocity field of the solvent needs to be specified. For **User defined**, enter values or expressions for the velocity components in the input fields. This input option is always available. You can also select the velocity field solved for by a Fluid Flow interface added to the model component. These physics interfaces are available for selection in the **Velocity field** list.

## DIFFUSION

Use this section to specify diffusion coefficients describing the diffusion of each species in the solvent liquid.

Use the **Source** list to select to pick up diffusion coefficients defined in a material or a Chemistry interface.

Select **Material**, and a **Liquid material** to use a diffusion coefficient in a material available in the model. User-defined property groups including a diffusion coefficient output property are available for selection in the **Liquid diffusion coefficient** list.

Select **Chemistry** to use a diffusion coefficient from a Chemistry interface added to model component. Diffusion coefficients are automatically defined when **Calculate transport properties** is selected on the interface level of a Chemistry interface. All defined diffusion coefficients are available for selection in the **Liquid diffusion coefficient** list.

For **User defined**, enter a value or expression for the **Liquid diffusion coefficient**  $D_{L,i}$  of each species in the corresponding input field.

In a porous medium the diffusivity is reduced due to the fact that the solid grains impede Brownian motion. Select an **Effective diffusivity model, liquid** to account for the reduced diffusivity in the liquid. The available models are **Millington and Quirk model** (the default), **Bruggeman model**, **Tortuosity model**, or **No correction**. For **Tortuosity model**, enter a value for the tortuosity  $\tau_{L,i}$  (dimensionless).

Note that multiple species, as well as Migration in Electric fields (described below) is only available for certain COMSOL Multiphysics add-on products. For details see: [www.comsol.com/products/specifications/](http://www.comsol.com/products/specifications/).

## MIGRATION IN ELECTRIC FIELD

This section is available when the **Migration in electric field** checkbox is selected. From the **Electric potential** list, select the source of the electric field.

- For **User defined**, enter a value or expression for the **Electric potential**  $V$ . This input option is always available.
- Select the electric potential solved by an AC/DC-based interface that has added to the component.
- Select the electric potential defined or solved for by an Electrochemistry interface added to the component.

By default the **Mobility** is set to be calculated based on the species effective diffusivity and the temperature using the **Nernst–Einstein relation**. For **User defined**, select the appropriate scalar or tensor type — **Isotropic**, **Diagonal**, **Symmetric**, or **Full** — and type in the value or expression of the effective mobility  $u_{me,i}$ .

Enter the **Charge number**  $z_c$  for each species.

### *Gas*

---

Use this node to specify the mass transfer in the gas phase present in the pores of the [Unsaturated Porous Medium](#).

## DIFFUSION

The settings for the diffusion of each species in the gas phase are identical to those in the [Liquid](#) subnode.

## VOLATILIZATION

Enter a value for the volatilization isotherm  $k_{G,c}$  (dimensionless) for each species.

### *Adsorption*

---

Use this node to model adsorption of the (fluid phase) solute species onto the surface of the porous matrix. It is available as a subnode to the [Porous Medium](#) and the [Unsaturated Porous Medium](#) nodes.



This feature is only available in a limited set of add-on products. See [www.comsol.com/products/specifications/](http://www.comsol.com/products/specifications/) for more details on availability.

---

## MATRIX PROPERTIES

The density of the porous media is needed when modeling adsorption to the surface of the porous matrix. Choose to input either the **Dry bulk density**  $\rho$ , or the **Solid phase density**  $\rho_s$ . The former is the density of the porous matrix including empty pores, while the latter corresponds to the density of the pure solid phase. The density can be defined from the domain material by selecting **From material**, or from a user defined expression. When a **Porous Material** is used on the selection, the density will be requested from a **Solid** subfeature. Several **Solid** features can be used to model a homogeneous mixture of several solid components.

## ADSORPTION

Select an **Adsorption isotherm** — **Langmuir**, **Freundlich**, **Toth**, **BET**, or **User defined** to specify how to compute  $c_P$ , the amount of species sorbed to the solid phase (moles per unit dry weight of the solid):

- For **Langmuir**:

$$c_P = c_{Pmax} \frac{K_L c}{1 + K_L c}, \quad K_P = \frac{\partial c_P}{\partial c} = \frac{K_L c_{Pmax}}{(1 + K_L c)^2}$$

Enter a **Langmuir constant**  $k_{L,c}$  (SI unit:  $m^3/mol$ ) and an **Adsorption maximum**  $c_{p,max,c}$  (SI unit: mol/kg).

- For **Freundlich**:

$$c_P = K_F \left( \frac{c}{c_{ref}} \right)^N, \quad K_P = \frac{\partial c_P}{\partial c} = N \frac{c_P}{c}$$

Enter a **Freundlich constant**  $k_{F,c}$  (SI unit: mol/kg), a **Freundlich exponent**  $N_{F,c}$  (dimensionless), and a **Reference concentration**  $c_{ref,c}$  (SI unit: mol/ $m^3$ ).

- For **Toth**:

$$c_P = c_{Pmax} \frac{b_T c}{(1 + (b_T c)^{N_T})^{1/N_T}}$$

and

$$K_P = \frac{\partial c_P}{\partial c} = c_{P\max} b_T (1 + (b_T c)^{N_T})^{-\left(1 + \frac{1}{N_T}\right)}$$

Enter a **Toth constant**  $b_{T,c}$  (SI unit:  $\text{m}^3/\text{mol}$ ), a **Toth exponent**  $N_{T,c}$  (dimensionless), and an **Adsorption maximum**  $c_{p,\max,c}$  (SI unit:  $\text{mol}/\text{kg}$ ).

- For **BET (Brunauer–Emmett–Teller)**:

$$c_P = \frac{K_B c_0 c}{(c_S - c) \left( 1 + (K_B - 1) \frac{c}{c_S} \right)}$$

and

$$K_P = \frac{\partial c_P}{\partial c} = \frac{K_B c_0 c_S ((K_B - 1) c^2 + c_S^2)}{(c - c_S)^2 (c_S + (K_B - 1) c)^2}$$

Enter a **BET constant**  $K_{B,c}$  (dimensionless), a **Monolayer adsorption capacity**  $c_{0,c}$  (SI unit:  $\text{mol}/\text{kg}$ ), and an **Saturation concentration**  $c_{S,c}$  (SI unit:  $\text{mol}/\text{m}^3$ ).

- For **User defined** enter an **Adsorption isotherm**  $c_{P,c}$  (SI unit:  $\text{mol}/\text{kg}$ ):

$$c_P = f(c)$$

For more information, see [Adsorption](#) in the theory section.

#### FURTHER READING

See the theory chapter in the section [Mass Balance Equation for Transport of Diluted Species in Porous Media](#).

#### *Volatilization*

---

This feature is available when the **Mass transfer in porous media** checkbox is selected in the **Settings** window for the physics interface.

Use this feature to model mass transfer at the boundary due to volatilization. The species dissolved in the liquid are assumed to be vaporized at the boundary, and transported into the surrounding bulk region due to convection and diffusion. The mass transfer at the boundary is defined as

$$-\mathbf{n} \cdot \mathbf{J}_c = -h_c (k_{G,c} c - c_{\text{Gatm},c})$$

where  $h_c$  is the mass transfer coefficient,  $k_{G,c}$  the volatilization coefficient, and  $c_{\text{Gatm},c}$  the concentration in the surrounding atmosphere.



This feature is only available in a limited set of add-on products. See [www.comsol.com/products/specifications/](http://www.comsol.com/products/specifications/) for more details on availability.

### **VOLATILIZATION**

Enter a **Mass transfer coefficient**  $h_c$  defining the transfer into the surrounding media. This can be given by boundary layer theory. When assuming that no convective flow is present in the surrounding, the mass transfer coefficient can be defined from the gas diffusion coefficient  $D_{Gc}$  and the thickness of the diffusion layer  $d_s$  in the manner of

$$h_c = \frac{D_{Gc}}{d_s}$$

Also give the atmospheric concentration for each species,  $c_{\text{Gatm},c}$ . The **Volatilization** coefficient  $k_{G,c}$  for each species are taken from the adjacent **Unsaturated Porous Medium** domain.

### *Species Source*

In order to account for consumption or production of species in porous domains, the **Species Source** node adds source terms expressions  $S_i$  to the right-hand side of the species transport equations.

### **DOMAIN SELECTION**

From the **Selection** list, choose the domains on which to define rate expression or expressions that govern the source term in the transport equations.

If there are several types of domains, with subsequent and different reactions occurring within them, it might be necessary to remove some domains from the selection. These are then defined in an additional **Species Source** node.

### **SPECIES SOURCE**

Add a source term  $S_i$  (SI unit: mol/(m<sup>3</sup>.s)) for each of the species solved for. Enter a value or expression in the field of the corresponding species.

## Hygroscopic Swelling

---

The **Hygroscopic Swelling** multiphysics coupling node (  ) is used for moisture concentration coupling between the Solid Mechanics interface and either the Transport of Diluted Species or Transport of Diluted Species in Porous Media interfaces.

Hygroscopic swelling is an effect of internal strain caused by changes in moisture content. This volumetric strain can be written as

$$\varepsilon_{hs} = \beta_h M_m (c_{mo} - c_{mo,ref})$$

where  $\beta_h$  is the coefficient of hygroscopic swelling,  $M_m$  is the molar mass,  $c_{mo}$  is the moisture concentration, and  $c_{mo,ref}$  is the strain-free reference concentration.

This feature requires a license of either the MEMS Module or the Structural Mechanics Module. The multiphysics feature will appear automatically if both the Transport of Diluted Species and the Solid Mechanics interfaces are added to the same component. For the most current information about licensing, please see [www.comsol.com/products/specifications/](http://www.comsol.com/products/specifications/).

### FURTHER READING

More information about how to use hygroscopic swelling can be found in the [Hygroscopic Swelling](#) section in the *Structural Mechanics Module User's Guide*.

More information about multiphysics coupling nodes can be found in the section [The Multiphysics Branch](#) in the *COMSOL Multiphysics Reference Manual*.

## Out-of-Plane Flux

---

The out-of-plane flux node is used to prescribe a flux in an out-of-plane domain, and it can be used to reduce a model geometry to 2D, or even 1D, when the concentration variation is small in one or more directions. This could be the case for example when

the object to model is thin or slender. Figure 4-1 shows examples of possible situations in which this type of geometry reduction can be applied.

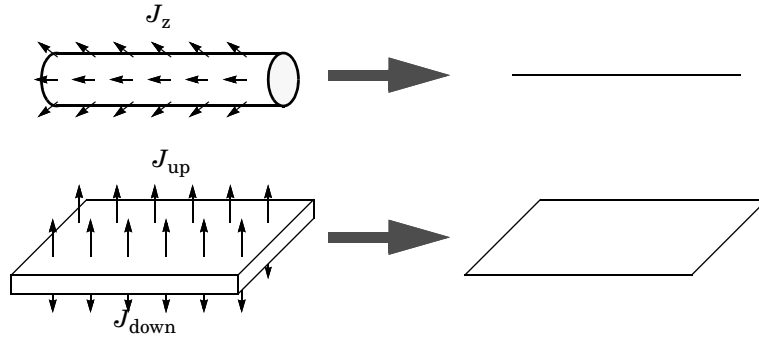

Figure 4-1: Geometry reduction from 3D to 1D (top) and from 3D to 2D (bottom).

For a 1D component this node adds a single out-of-plane molar flux  $J_{0,z,i}$  for species  $i$ . For a 2D component two fluxes can be prescribed for each species;  $J_{0,u,i}$  for the upside of the domain, and  $J_{0,d,i}$  for the downside of the domain.

The fluxes are added as a source contribution to the right-hand side of the transport equation. For example, in 2D components with diffusion, convection, and out-of-plane flux present, the mass transfer of species  $i$  is defined by the mass conservation equation

$$\frac{\partial c_i}{\partial t} + \nabla \cdot \mathbf{J}_i + \mathbf{u} \cdot \nabla c_i = R_i + S_{\text{opf},i}, \quad (4-1)$$

where  $S_{\text{opf},i}$  is the out-of-plane source for species  $i$

$$S_{\text{opf},i} = \frac{J_{0,i}}{d_z} = \frac{J_{0,u,i} + J_{0,d,i}}{d_z}.$$

For external convection on the upside and the downside of the domain, the out-of-plane flux is

$$J_{0,i} = k_{c,u,i}(c_{b,u,i} - c_i) + k_{c,d,i}(c_{b,d,i} - c_i)$$

where  $k_c$  is a mass transfer coefficient and  $c_b$  is the bulk concentration, the typical concentration far into the surrounding exterior domain. The prescribed flux,  $J_0$ , can

include any arbitrary user-specified expressions. It can be a constant or a function of a dependent variable or independent variables.

### UPSIDE INWARD FLUX

For 1D components, enter the **cross-sectional perimeter**  $P_c$  to get the out-of-plane flux

$$J_{0,i} = P_c J_{0,z,i}$$

The default value of  $P_c$  is the circumference. Either keep the default value, for a circular cross-section shape, or edit the value to get a user-defined shape of the out-of-plane cross-section.

The available flux type options are **General inward flux** and **External convection**. Select the **Species** checkbox for the species for which to specify the flux, and enter a value or expression for the inward flux in the corresponding field. Use a minus sign when specifying a flux directed out of the system. To use another boundary condition for a specific species, click to clear the checkbox for that species.

Set **Flux type** to **External convection** to prescribe a flux to or from an exterior domain (not modeled) assumed to include convection. The exterior can for example include a forced convection to control the temperature or to increase the mass transport. In this case the prescribed mass flux corresponds to

$$J_0 = k_c(c_b - c)$$

where  $k_c$  is a mass transfer coefficient and  $c_b$  is the bulk concentration, the typical concentration far into the surrounding exterior domain.

### DOWNSIDE INWARD FLUX

The available options are **General inward flux** and **External convection**. The settings are the same as for the [Upside Inward Flux](#) section.

### FURTHER READING

For an example of using the Out-of-Plane Flux node, see this application example:



*Cross-Flow Mass Transfer in a Thin Domain*: Application Library path  
**Chemical\_Reaction\_Engineering\_Module/Tutorials/thin\_domain**

---

## Fracture

---

Use this node to model mass transport along thin fractures in porous media. The node assumes that the transport in the tangential direction along the fracture is dominant as a result of lower flow resistance.

The Fracture feature has two default subfeatures — the [Fluid \(Fracture\)](#) subfeature where convection and diffusion are specified and the [Fracture Material](#) subfeature where the porosity  $\epsilon_p$  is defined.



This feature is only available in a limited set of add-on products. See [www.comsol.com/products/specifications/](http://www.comsol.com/products/specifications/) for more details on availability.

### FRACTURE PROPERTIES

Specify a value for the **Fracture thickness**  $d_{fr}$ .

For the **Fracture** boundary condition, there are a number of **Attributes** available which can be accessed either via the **Physics** Ribbon toolbar (for Windows) or by right-clicking on the **Fracture** node. These attributes are identical to the [Boundary, Edge, Point, and Pair Nodes for the Transport of Diluted Species in Fractures Interface](#) described, for example, in the *Chemical Reaction Engineering Module User's Guide*.

## Fluid (Fracture)

---

Use this node to specify the mass transfer in the mobile fluid solvent filling the pores of a fracture.

It uses the same input options as the [Fluid \(Porous Medium\)](#) subfeature under the [Porous Medium](#) feature. There are further details about the settings.

### MODEL INPUTS

The temperature model input is always available. By default, the **Temperature** model input is set to **Common model input**, and the temperature is controlled from **Default Model Inputs** under **Global Definitions** or by a locally defined **Model Input**. If a Heat Transfer interface is included in the component, it controls the temperature **Common model input**. Alternatively, the temperature field can be selected from another physics interface. All physics interfaces have their own tags (**Name**). For example, if a Heat

Transfer in Fluids interface is included in the component, the **Temperature (ht)** option is available for T.

### CONVECTION

If transport by convection is active, the velocity field of the solvent needs to be specified. Select an option from the **Velocity field** list to specify the convective velocity along the fracture. For a consistent model, use a Fracture feature in a Darcy's Law interface to compute the fluid flow velocity in the fracture.

For **User defined**, enter values or expressions for the velocity components in the table shown

### DIFFUSION

Use this section to specify diffusion coefficients describing the diffusion of each species in the solvent fluid.



The **Diffusion** settings are similar to those for the diffusion coefficients in the **Fluid (Porous Medium)** node under **Porous Medium**.

---

### *Fracture Material*



---

Specify the **Porosity**  $\epsilon_p$  (dimensionless) of the porous matrix. This is by default taken **From material**. Select **From pellet bed densities** to compute the porosity from the (dry bulk) **Bed density**  $\rho_b$  and the (single phase) **Pellet density**  $\rho_{pe}$  through the relation

$$\epsilon_p = 1 - \frac{\rho_b}{\rho_{pe}}$$

For **User defined**, enter a value or expression for the porosity.

# The Chemistry Interface

The **Chemistry (chem)** interface () is found under the **Chemical Species Transport** branch () when adding a physics interface.

This physics interface is a tool for generating a set of variables to be used for modeling chemical species and reactions systems. The variables are generated from species and reaction properties and can be divided in two categories:

- Rate expressions and heat sources for use in mass and heat balances.
- Material property variables (mixture density, diffusivities, viscosity, and so on) for use in space-dependent transport equations.

Many of the fields and nodes described in this section are only made available when either a [Reaction](#) or a [Species](#) (or both) subnode is added to the Model Builder. All predefined constants and expressions can be overwritten by user-defined expressions. This makes it possible to go beyond the modeling assumptions set as defaults in this physics interface.

The following is a description of the features and fields available in the **Settings** window for the Chemistry interface.

## SETTINGS

The **Label** is the default physics interface name.

The **Name** is used primarily as a scope prefix for variables defined by the physics interface. Refer to such physics interface variables in expressions using the pattern `<name>.<variable_name>`. In order to distinguish between variables belonging to different physics interfaces, the `name` string must be unique. Only letters, numbers, and underscores (`_`) are permitted in the **Name** field. The first character must be a letter.

The default **Name** (for the first physics interface in the model) is `chem`.

## MODEL INPUT

This section sets the **Temperature**, **Pressure**, and **Electrode potential** (only available with a Battery Design Module, Corrosion Module, Electrochemistry Module, Electrodeposition Module, or Fuel Cell & Electrolyzer Module license) to be used by the current interface. Toggle the **Enable electrode reactions** checkbox to enable the Electrode Potential input in the [Model Input](#) section, as well as the [Electrode Reaction](#) and [Electrode Reaction Group](#) features. Use the lists to select a temperature, pressure,

or electrode potential defined and announced by another interface in the model. For example, when a heat transfer interface is also included, the temperature solved for is available in the **Temperature** list.

For **Temperature** or **Pressure**, you can also select **Common model input** to use a globally available common model input. In all three cases, select **User defined** to manually define the variable in question.

### *Mixture Properties*

---

#### *Type*

Use this setting to define specify what kind of mixture assumption is used. For **Diluted Species** the mixture is composed of low concentration solutes present in a solvent. For **Concentrated Species** a mixture where no single species is considered to be in excess is assumed.

Select **Diluted species** from the **Type** list to use the concentration variables from a Transport of Diluted Species interface in the [Species Matching](#) section. The same setting should be used for any other interface solving for molar concentrations using a diluted species assumption. Select **Concentrated species** from the **Type** list to use the mass fractions from a Transport of Concentrated Species interface.

#### *Thermodynamics*

All property parameters and property functions required by the interface can be automatically created by coupling to a system added to the **Thermodynamics** node. To do so, click the **Thermodynamics** checkbox and select an existing [Thermodynamic System](#).

The **Thermodynamics** checkbox is enabled when the [Thermodynamics](#) node, including one or more systems, is available under **Global Definitions**. Also, the Chemistry interface needs to include at least one species.

#### *Phase*

Use the **Phase** list to specify the state of aggregation of the mixture.

### **SPECIES MATCHING**

This section is used to match species solved for in space dependent physics interfaces to the species defined in Chemistry. By doing so the variables for the reaction kinetics and the mixture properties defined by Chemistry can be applied to study chemically reacting or composition dependent systems.

### *Species Solved For*

Use this list to populate the inputs in the **Bulk species** table with dependent variables from a certain mass transfer interface. The **Species solved for** list contains all present interfaces of the **Type** selected in the **Mixture Properties** section. For example, when the **Type** is **Diluted species**, all Transport of Diluted Species interfaces or variants thereof, such as Transport of Diluted Species in Porous Media interface, are available in the list.

### *Bulk Species*

Use the **Bulk species** table to specify the concentrations to be used as arguments in reaction kinetics variables, for example the reaction rate. Reaction kinetics variables are generated by the species features ([Species](#) and [Species Group](#)) and by the reaction features ([Reaction](#), [Electrode Reaction](#), [Reversible Reaction Group](#), [Electrode Reaction Group](#), and [Equilibrium Reaction Group](#)).

The bulk species concentrations are also used in the mixture properties, both for transport properties like the density and viscosity, and thermodynamic properties like the enthalpy or heat capacity.

When a mass transfer interface has been selected in the **Species solved for** list, use the **Molar concentration** column to select one of the dependent variables in the selected interface to the corresponding **Species** in Chemistry. When using a concentrated species interface (defined by the **Type** list in the [Mixture Properties](#) section), instead use the **Mass fraction** column to select a dependent variable for each species in Chemistry. For a consistent set up, the species molar mass in the Transport of Concentrated Species interface is updated to the one defined in the Chemistry interface.

The **Molar concentration** and **Mass fraction** columns also includes a **User defined** option, in which case a constant, parameter, or variable expression can be entered in the **Value** column.

### *Thermodynamics Coupling*

When the [Thermodynamics](#) is enabled, the species in the Chemistry interface can be coupled to the species in the [Thermodynamic System](#). This is needed to ensure that arguments for the thermodynamic functions are correctly defined. Use the lists in the **From Thermodynamics** column to match each species in the Chemistry to a species in the coupled thermodynamic system. For each thermodynamics-coupled species, the required property parameters and functions are added under the corresponding thermodynamic system. When all species are matched, the Chemistry is considered fully coupled and functions representing mixture properties, such as the density, are also added automatically under the same thermodynamic system.

### *Surface Species*

The **Surface Species** table is available when there is at least one surface species (with “(ads)” as suffix).

Similar to the table for **Bulk Species**, the surface species can be matched (or coupled) directly to the surface species dependent variables if the Chemistry is coupled to a mass transfer interface where the surface concentration is solved. There are three cases where mass transfer interfaces solve surface species concentration (s).

- **Surface Reactions** physics interface;
- **Packed Bed** feature (with surface species transport in pellet) available in the **Transport of Diluted Species or Transport of Concentrated Species**;
- **Porous Catalyst** feature (with surface species transport in catalyst) available in the **Transport of Diluted Species or Transport of Concentrated Species**.

The last column **Value(mol/m<sup>2</sup>)** will be automatically set to **Solved for** when a surface species dependent variable is selected under the column **Surface concentration**. Otherwise for a User defined being for **Surface concentration** column, specify the concentration of surface species **Value(mol/m<sup>2</sup>)** column.

In addition, if a surface species is present at the same time as an [Electrode Reaction](#), the **Density of sites** input field becomes visible. The **Density of sites** input value will be used as the default reference concentration for surface species reacting in an [Electrode Reaction](#).

The species present in this section will not be used to define mixture properties.

### *Solid Species*

The **Solid Species** table is available when there is at least one solid species (with “(s)” as suffix). When present, use the table to specify the concentration of solid species.

Solid species may affect reaction kinetics, but does not contribute to mixture properties.

### *Aqueous Species*

The **Aqueous Species** table is available when there is at least one aqueous species (with “(aq)” as suffix). When present, use the table to specify the concentration of aqueous species.

Aqueous species may affect reaction kinetics, but does not contribute to mixture properties.

### *Equilibrium Reaction Rate Table*

This table is only available when equilibrium reactions are present in the interface. Use the **Reaction rate** column to specify the rate for each equilibrium reaction. By doing so the postprocessing variable for the total reaction rate for each species, of form `chem.Rsum_species`, will be updated correctly. For a mass transport interface, say Transport of Diluted Species, the reaction rate needed for an equilibrium reaction is typically a dependent variable. In that case, the name of the variable can be found in the **Shape Function** section of the **Equation View** of the node.

When the Chemistry interface is created using from the **Generate Space-Dependent Model** the table is automatically set up in accordance with the added equilibrium reaction nodes.

### **CALCULATE TRANSPORT PROPERTIES**

Select the **Calculate mixture properties** checkbox (selected as default) to calculate mixture properties that can be picked up in the space-dependent model interfaces. The properties that can be calculated are shown beneath the checkbox. There are four properties, heat capacity, ratio of specific heats, thermal conductivity and dynamic viscosity. For these properties, the **Automatic** and **User defined** are always available, the **Thermodynamics** is available when all bulk species are coupled to a **Thermodynamic System** (fully coupled). Consider also if the built-in **Automatic** expressions fit the model or if **User defined** expressions are more suitable.

The density and diffusion coefficient are always calculated.

It could be costly to calculate mixture properties by **Automatic** or **Thermodynamics** if there are a lot of species. The calculations of mixture properties are set to the **User defined** when the number of species from an imported file (a CHEMKIN file or a reaction file) exceeds the maximum number (default 200). The maximum number can be changed by entering a new value in the **Maximum number of species for mixture property models** field. This field is visible when a **Reversible Reaction Group** has the checkbox **Import CHEMKIN data** selected.



Transport Properties

---

### **ACTIVITY**

This section is available when the **Thermodynamics** checkbox is cleared.

Select the **Use activity** checkbox to solve for species activities instead of species concentrations, which is a common approach when nonideal fluids are modeled.

An activity coefficient other than 1 can be set for each species for the [Species](#) node in the **Species Concentration/Activity** section.

### CHEMKIN IMPORT FOR SPECIES PROPERTIES

It is available when the **Thermodynamics** checkbox is cleared.

This section enables CHEMKIN<sup>®</sup> import to simulate complex chemical reactions in gas phase.

Two types of CHEMKIN input files can be imported here: **Thermo** and **Transport**, for thermodynamic properties and transport properties, respectively. Properties for either volumetric or surface species are supported. Click **Browse** to locate the CHEMKIN file to be imported, then click **Import**. For **Thermo**, the imported data is directly entered in the **NASA format** fields in the [Species](#) node's **Thermodynamic Expressions** section; for **Transport**, the imported data is entered in its **Transport Expressions** section.

### *Feature Nodes Available for the Chemistry Interface*

---

The following feature nodes are available from the **Chemistry** ribbon toolbar (Windows users), **Chemistry** context menu (Mac or Linux users), or right-click to access the context menu (all users).

- [Equilibrium Reaction Group](#)
- [Reaction](#)
- [Electrode Reaction](#)
- [Electrode Reaction Group](#)
- [Reversible Reaction Group](#)
- [Species](#)
- [Species Activity](#)
- [Species Group](#)
- [Species Thermodynamics](#)<sup>1</sup>

### *Reaction*

---

Use the **Reaction** node (  ) to define a chemical reaction where one or several species form other chemical species.

To add a **Reaction** node either right-click the **Chemistry** node, or click **Reaction** in the **Chemistry** toolbar.



## Using the Reaction Node

### REACTION FORMULA

#### *Formula*

Enter a chemical equation in the **Formula** field. The chemical equation should be of the format “A + B  $\rightarrow$  C + D”. Here, A and B are reactants, C and D are product species, and  $\rightarrow$  denotes a reaction arrow. The participating species should be written with [Valid Species Names](#). Valid reaction arrows are “ $\rightleftharpoons$ ” for reversible reaction, “ $\Rightarrow$ ” for irreversible reaction, and “ $\rightleftharpoons$ ” for equilibrium reaction. Species can be given trivial names, or their chemical formulas can be used as names. Examples of valid formulas are; “carbon+oxygen $\Rightarrow$ carbondioxide”, and “C(s)+O<sub>2</sub>(g) $\Rightarrow$ CO<sub>2</sub>(g)”.

Click **Apply** to make the interface examine the species taking part in the chemical equation, and automatically add the associated [Species](#) features to the Model Builder.

#### *Balance* ()

Use the **Balance** button to automatically calculate the stoichiometric coefficients such that the number of atoms of each kind are the same on both sides of the reaction. This turns, for example, the formula “H<sub>2</sub>+O<sub>2</sub> $\Rightarrow$ H<sub>2</sub>O” into “2H<sub>2</sub>+O<sub>2</sub> $\Rightarrow$ 2H<sub>2</sub>O”. The balancing involves parsing all participating species for elements in the periodic table. It therefore requires that all species in the **Formula** field are written either using their chemical formula, say “H<sub>2</sub>O”, or that each species in the reaction have an enabled **Chemical Formula** field in their **Species** node. For example, it is possible to balance the formula “H<sub>2</sub>+O<sub>2</sub> $\Rightarrow$ water” as long as there is a Species node with the name “water” already present, and an enabled **Chemical Formula**.

For automatic reaction balancing to be successful, requires that the problem is well posed. One example of a problem that is not well posed is “C+H<sub>2</sub> $\Rightarrow$ CH<sub>4</sub>+C<sub>2</sub>H<sub>6</sub>”, in which case any ratio of CH<sub>4</sub>/C<sub>2</sub>H<sub>6</sub> could be obtained. Another example is “H<sub>2</sub> $\Rightarrow$ O<sub>2</sub>” where not all elements are present on both sides.

### Reaction Type

Select the **Reaction type** — **Reversible**, **Irreversible**, or **Equilibrium** — or edit the expression directly in the **Formula** field. In the latter case, specify the reaction type with a delimiter separating the two sides of the equation:

- $\rightleftharpoons$  denotes a **Reversible** reaction
- $\Rightarrow$  denotes an **Irreversible** reaction
- $=$  denotes a reaction at chemical **Equilibrium**

Each **Reaction type** has its own set of reaction kinetics:

- If the reaction is **Reversible** or **Irreversible**, the reaction rate for reaction  $i$  contributes to the change in species  $i$  as follows:

$$R_i = \sum_j \nu_{ij} r_j \quad (4-2)$$

where  $\nu_{ij}$  is the stoichiometric coefficient.

- If it is an **Equilibrium** reaction, the equilibrium expression is equal to the equilibrium constant:

$$K_{\text{eq}} = K_{\text{eq}0}$$

### REACTION RATE

This section is available when the **Reaction type** is either **Reversible** or **Irreversible**.

When **Mass action law** is selected (default), the rate expression is automatically derived from the stoichiometric coefficients in the reaction formula:

- For an **Irreversible** reaction type, the reaction rate becomes:

$$r_j = k_j^f \prod_{i \in \text{react}} c_i^{-\nu_{ij}} \quad (4-3)$$

- For a **Reversible** reaction type, the expression instead becomes:

$$r_j = k_j^f \prod_{i \in \text{react}} c_i^{-\nu_{ij}} - k_j^r \prod_{i \in \text{prod}} c_i^{\nu_{ij}} \quad (4-4)$$

The deduced overall reaction order is shown in text below the respective equation in the **Reaction Rate** section.

### Arbitrary Rate Expression

If the reaction order differs from the stoichiometric coefficients, or if an arbitrary rate expression is applicable, change **Reaction Rate** to **User defined**. An expression field  $r$  appears with the default expression being that from the mass action law. Below this there are fields to set the reaction order. For a reversible reaction the reverse reaction order may be specified in addition to the forward one. The unit of the rate constant  $k$  (or frequency factor  $A$  in the case of Arrhenius behavior), is derived from the reaction order, in SI units:  $(\text{m}^3/\text{mol})^{\alpha-1}/\text{s}$ , where  $\alpha$  equals the order with respect to volumetric species. When surface species are present — identified by their “(ads)” suffix — the unit is instead given by  $\text{m}^{3\alpha+2\beta-2}/\text{mol}^{\alpha+\beta-1}/\text{s}$ , where  $\beta$  is the order with respect to surface species.

Consider for example the reaction:

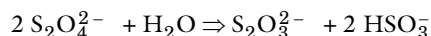

The automatically deduced reaction order is three, however, in the case that water is the solvent, the order should probably be two. This is specified as follows:

The screenshot shows the 'Settings' dialog for a reaction. The 'Reaction' label is '1: 2 SO4-- + H2O => S2O3-- + 2 HSO3-'. The 'Reaction Formula' is '2 SO4-- + H2O => S2O3-- + 2 HSO3-'. The 'Reaction type' is 'Irreversible'. The 'Reaction Rate' is set to 'User defined' with the expression 're.kf\_1\*re.c\_SO4\_2m^2' and unit 'mol/(m^3\*s)'. The 'Rate Constants' section has 'Use Arrhenius expressions' unchecked, 'Forward rate constant' set to 'k^f 1' with unit 'm^3/(mol\*s)'. The 'Reaction Orders' section has 'Volumetric overall reaction order' set to '2'. Annotations point to the 'User defined' dropdown, the rate expression field, the 'Use Arrhenius expressions' checkbox, and the 'Volumetric overall reaction order' field.

- Change to User Defined
- Adjust rate expression
- Override reaction order
- Note effect on unit

Figure 4-2: The reaction order can be manually specified for a user defined reaction rate.

## RATE CONSTANTS

This section applies for **Reversible** or **Irreversible** reactions and defines the reaction rate constants used in the reaction rates.

### *Forward Rate Constant and Reverse Rate Constant*

The **Forward rate constant**  $k^f$  is used for both **Reversible** and **Irreversible** reactions. The **Reverse rate constant**  $k^r$  is only used for **Reversible** reactions (Equation 4-3).

The SI units of the rate constants are automatically based on the order of the reaction with respect to the concentrations, as defined in the **Reaction formula**.

### *Specify Equilibrium Constant*

The **Specify equilibrium constant** checkbox is available for **Reversible** reactions. If the checkbox is selected the rate constants are defined in a different manner with the reverse rate constant being computed from the following expression:

$$k^r = k^f / K_{\text{eq}0}$$

Thus, in this case, the forward rate constant and equilibrium constant for the reaction are needed. The **Equilibrium constant** is edited in the [Equilibrium Settings](#) section.

### *Use Arrhenius Expressions*

When the **Use Arrhenius expressions** checkbox is selected the Arrhenius parameters are automatically used in predefined expressions for the forward and reverse rate constants  $k^f$  and  $k^r$ , respectively.

$$k^f = A^f (T/T_{\text{ref}})^{n^f} \exp(-E^f/(R_g T))$$

$$k^r = A^r (T/T_{\text{ref}})^{n^r} \exp(-E^r/(R_g T))$$

Specify the activation energy and the frequency factor in the Arrhenius expressions to account for temperature variations. The reference temperature,  $T_{\text{ref}}$  equals 1 K. The available fields are based on the **Reaction type** chosen in the [Reaction](#) node. Enter values or expressions for each of the following (reverse expressions are only available for reversible reactions):

- **Forward frequency factor**  $A^f$  and **Reverse frequency factor**  $A^r$  (unit depends on reaction order)
- **Forward temperature exponent**  $n^f$  and **Reverse temperature exponent**  $n^r$
- **Forward activation energy**  $E^f$  and **Reverse activation energy**  $E^r$  (SI unit: J/mol)

## EQUILIBRIUM SETTINGS

This section is available for equilibrium reactions, and for reversible reactions when the **Specify equilibrium constant** checkbox has been selected.

### *Equilibrium Expression*

For an equilibrium reaction, specify the **Equilibrium expression**. When the **Equilibrium expression** is set to **Automatic** the following expression is used:

$$K_{\text{eq}j} = \frac{\prod_{i \in \text{prod}} c_i^{v_{ij}}}{\prod_{i \in \text{react}} c_i^{-v_{ij}}}$$

Select **User defined** from the **Equilibrium expression** list to instead enter a manually defined equilibrium expression.

### *Equilibrium Constant*

Specify the **Equilibrium constant**  $K_{\text{eq}0}$  for an equilibrium reaction, or for a reversible reaction when the **Specify equilibrium constant** checkbox has been selected (in the **Rate Constants** section).

The **Equilibrium constant** can either be **User defined**, or automatically defined when set to **Automatic** or **Thermodynamics**.

Use the **Automatic** option to compute the equilibrium constant for an ideal system.

The **Thermodynamics** option is available when all reactions in the interface are equilibrium reactions, and the interface is fully coupled to a [Thermodynamic System](#) (see [Species Matching](#)). Use this setting to automatically compute the equilibrium constant for an ideal or nonideal system, dependent on the thermodynamic model applied for the coupled system.

Using **Automatic** or **Thermodynamics**,  $K_{\text{eq}0}$  is calculated from the Gibbs free energy of the reaction. For more details see [The Equilibrium Constant](#) and the [Automatically Defined Equilibrium Constants](#) section therein.

## REACTION THERMODYNAMIC PROPERTIES

This section contains information about thermodynamic properties that relate to a selected reaction. Several **Automatic** definitions are available here.

### Enthalpy of Reaction

The **Enthalpy of reaction**  $H$  (SI unit: J/mol) is calculated by the interface from species properties and the related stoichiometric coefficients:

$$H_j = \sum_{i \in \text{prod}} \nu_{ij} h_i - \sum_{i \in \text{react}} (-\nu_{ij}) h_i \quad (4-5)$$

### Entropy of Reaction

The **Entropy of reaction**  $S$  (SI unit: J/(mol·K)) comes from a similar expression:

$$S_j = \sum_{i \in \text{prod}} \nu_{ij} s_i - \sum_{i \in \text{react}} (-\nu_{ij}) s_i \quad (4-6)$$

In [Equation 4-5](#) and [Equation 4-6](#),  $h_i$  and  $s_i$  are the species' molar enthalpy and molar entropy, respectively.

Enter these quantities in the **Species Thermodynamic Expressions** section for the [Species](#) node either by using the predefined polynomial or by providing a custom expression or constants.

The stoichiometric coefficients,  $\nu_{ij}$ , are defined as being negative for reactants and positive for products. Using [Equation 4-5](#) and [Equation 4-6](#) to equate the Gibbs free energy of reaction enables the equilibrium constant to be expressed according to [Equation 4-5](#).

### Heat Source of Reaction

The **Heat source of reaction** (SI unit: W/m<sup>3</sup>) is automatically computed from the heat of each reaction  $j$ , given by

$$Q_j = -H_j r_j$$

## TURBULENT FLOW

When a reaction occurs in a fluid within the turbulent flow regime, the reaction rate may be affected by the turbulent flow. Use the settings in this section to model reactions affected by turbulent flow.



The **Turbulent Flow** section is available when the below conditions are met:

- 1 The mixture **Type** is **Concentrated species** in the **Mixture Properties** section
- 2 Reversible or irreversible bulk reaction is considered
- 3 **Use activity** not selected in the **Activity** section
- 4 **Define variables for porous pellets** is not selected in the **Pellet Chemistry** section

### *Turbulent Flow*

When the **Turbulent-reaction model** is set to **None**, laminar flow is assumed and the reaction source terms are defined from the prescribed reaction rates.

When the **Turbulent-reaction model** is set to **Eddy-dissipation**, turbulent flow will be accounted for in the reaction mass sources in the manner described in the [Turbulent Reactions](#) section, and in [The Reaction Source Term for Turbulent Flow](#), in the *CFD Module User's Guide*. In this case, enter values for the **Turbulent reaction model parameters**  $\alpha_{ED}$  and  $\beta_{ED}$  (dimensionless).

The **Eddy-dissipation** model also requires an estimation of the turbulent mixing time of the fluid flow turbulence. When a Fluid Flow interface defining it is present in the model, it can be selected from the **Turbulence time scale** list. For example, select **Turbulence time scale (spf/fp1)** to use the time scale defined by the **Fluid Properties** node fp1 in a Turbulent Flow, *k*- $\epsilon$  interface with the **Name** set to spf.

**Assume Infinitely Fast Reaction** This checkbox is available when a valid turbulence model is selected. With the checkbox selected, the reaction rate is limited by the turbulent mixing, and the settings for kinetic reaction rates in the **Rate Constants** and **Reaction Orders** is not available.

### *Regularization*

Select **Reaction rate regularization** to regularize the individual rate expressions added to each species. If the mass fraction for a reactant species  $\omega_i$  becomes smaller than its **Damping limit**,  $\omega_i^{dl}$ , the rate expression, for species  $\omega_i$  is reduced linearly. If  $\omega_i \leq 0$  for a reactant species, the reaction rate contribution to that species is completely removed.

Similarly, if the mass fraction for a product species  $\omega_j$  becomes larger than  $1 - \omega_j^{\text{dl}}$ , the rate expression added is damped linearly. If  $\omega_j \geq 1$  for a product species, the reaction rate contribution to that species is completely removed.

The default value for the **Damping limit**,  $\omega_i^{\text{dl}}$ , is  $10^{-6}$ , which is appropriate for most applications, but can require adjustment when working with for example catalytic trace species.

Regularization of the rate expressions adds considerable stability to the reaction expressions, but it should ideally only be used as a means to reach convergence. When reaction zones are not adequately resolved on the mesh, regularization can affect the mass balance.



This section is available under the same conditions as those of the **Turbulent Flow** section.

---

## *Species*

---

When a **Reaction** is defined, a **Species** node (  ) is automatically generated for the participating reactants and products. This feature enables you to review and enter species specific information regarding chemical kinetics, thermodynamics, and transport properties.

It is also possible to add and define an individual **Species** node: in the **Chemistry** toolbar click **Species** or right-click the **Chemistry** node and select it from the context menu.

### **NAME**

When a **Species** node is automatically generated using the **Formula** text field for the Reaction node, the **Name** is also automatically generated.

For a **Species** node added individually, enter a **Name** in the field and click **Apply**. By entering a name consisting of elements from the periodic table, the molar mass is calculated and added in the **Chemical Formula** section. The species charge, and type, are also deduced from the species name.



Valid Species Names

---

## TYPE

Select a species type — **Bulk species**, **Surface species**, or **Solvent**. The latter is only available when a diluted solution is assumed. That is when **Type** is set to **Diluted Species** in the **Mixture Properties** section (in the interface level).

**Bulk species** and **Solvent** are solved for volumetric concentrations (SI unit: mol/m<sup>3</sup>), while **Surface species** are solved for surface concentration (SI unit: mol/m<sup>2</sup>). The compositions for **Bulk species** and **Solvent** use the syntax `c_speciesname`, while **Surface species** uses `csurf_speciesname_surf`.

When **Surface species** is selected, the corresponding reaction formula introduces **(ads)** after the species notation and changes the species' name to `speciesname_surf`. Additionally, the Species node name is updated in a similar fashion.

## CHEMICAL FORMULA

The **Chemical Formula** section contains the species chemical formula, **Molar mass**,  $M$ , and **Charge**,  $z$ .

If the name entered for the species consists of only elements from the periodic table, and optionally charge and phase indication, then the **Chemical Formula** field will be populated with the name entered in the **Name** section, and the molar mass and charge will be added to this section. The species molar mass is computed from the mass of occurring individual elements<sup>1</sup>. The rules for writing chemical formulas are the same as those for **Species** names.



### Valid Species Names

---

When the species name contains parts not in the periodic table, for example when a descriptive name such as **water** is used, the molar mass is set to 0.0 kg/mol and the charge to zero. In this case, the molar mass needs to be defined in order to achieve mass balanced reactions and correct definitions of mass basis properties. By entering a chemical formula consisting only of elements from the periodic table (and optionally charge and phase indication), the molar mass, and charge are derived automatically.

When needed, the **Molar mass** can be edited in the corresponding text field. Editing the **Chemical formula** and pressing apply will override the molar mass and charge fields. The **Charge** field cannot be edited as long as a chemical formula is enabled.

---

1. Values are averages of upper and lower bounds for each atom as published by CIAAW. Source: CIAAW. Atomic weights of the elements 2019. Available online at [www.ciaaw.org](http://www.ciaaw.org).

With an enabled **Chemical Formula** it is possible to use the trivial name of a species and balance reactions. Having added the Species water, oxygen, and hydrogen, and filled in H<sub>2</sub>O, O, and H in their respective chemical formula sections, the **Formula** oxygen+hydrogen=water is balanced into oxygen+2hydrogen=water by clicking **Balance** in the **Reaction** node.

It is possible to specify the species density  $\rho$  when the fluid **Mixture** is specified as **Liquid**. The default value is that of water at 293 K.

### REACTION RATE

Change the **Automatic** default setting to **User defined** to use a species reaction rate other than the one set up in the associated **Reaction** node. For individual species, use the **User defined** option to set a reaction rate other than zero (that is, nonreactive).

Edit either the **Rate expression** (SI unit: mol/(m<sup>3</sup>·s)), the **Surface rate expression** (SI unit: mol/(m<sup>2</sup>·s)), or both. For a bulk species, both expressions appear if surface reactions are present since the reaction of the species can depend both on bulk reaction  $R$  and surface reaction  $R_{\text{ads}}$  rates. For a surface species, only the surface reaction rate  $R_{\text{ads}}$  appears.

### ADDITIONAL SOURCE

The **Additional Source** section is available in order to include additional rate contribution for the species to the reaction kinetics. When the **Additional source** checkbox is selected, add an **Additional rate expression** in the text field (SI unit: mol/m<sup>3</sup>).

### CONSTANT CONCENTRATION/ACTIVITY

To account for nonideality in the fluid mixture, adjust the activity coefficient in the **Activity coefficient** input field. This input field is only shown if activity instead of concentration has been chosen in the interface, that is, the **Use activity** checkbox is selected on the Chemistry interface **Settings** window

Click to select the **Keep concentration/activity constant** checkbox if the species concentration or activity should be treated as constant.

### THERMODYNAMIC EXPRESSIONS

The parameters utilized for calculation of thermodynamic mixture and reaction properties are set in this section.

Choose the **User defined** alternative to specify  $C_p$ ,  $h$ , and  $s$  directly.

## Electrode Reaction

---

To add an **Electrode Reaction** node (  ) either right-click the **Chemistry** node or in the **Chemistry** toolbar click **Electrode Reaction**.

The **Electrode Reaction** subnode defines the electrode kinetics for a charge transfer reaction that occurs on an electrolyte-electrode interface boundary. Use multiple nodes to model multiple reactions, for instance in mixed potential problems.

This node is available with a Battery Design Module, Corrosion Module, Electrochemistry, Module, Electrodeposition Module, or Fuel Cell & Electrolyzer Module license.

### REACTION FORMULA

#### Formula

Enter an electrode reaction Formula, as a reduction reaction. Use the single letter “e” to symbolize an electron. The delimiter between reactants and products has to be written as “<=>” (without quotation marks). The phase of the species, that is (aq) for aqueous dilute ions, (s) for solids, and (g) for gases can be indicated in the name. The phase is used to select an automatic reference state (see [Reference Concentrations](#)) for computing the equilibrium potential using the Nernst equation. Click **Apply** to make the interface examine the species taking part in the model’s reactions and automatically add the associated [Species](#) features to the Model Builder.

### EQUILIBRIUM POTENTIAL

The Equilibrium potential,  $E_{\text{eq}}$  (SI unit: V), is used in the electrode kinetics expressions in the following section (via the definition of the overpotential), or for setting up primary current distribution potential constraints.

#### Nernst Equation

After providing the reference electrode potential, the equilibrium potential is calculated using the Nernst equation. The concentrations entered in the [Species Matching](#) section of the **Chemistry** interface will be used to calculate the equilibrium potential. The reference concentrations, defined in the [Reference Concentrations](#) section, will be used to compute the activities in the reaction quotient expression,  $Q_{\text{r}}$ .

#### Automatic

This option is only available if the **Calculate mixture properties** checkbox in the [Calculate Transport Properties](#) section is selected.

The [Species](#) enthalpies and entropies are used to calculate the equilibrium potential of the electrode reaction at the temperature and composition of the system.

If only species enthalpies and entropies at standard state are available, use the [Nernst Equation](#) option instead.

## REFERENCE CONCENTRATIONS

The reference concentrations for the species in the reaction can be changed here.

### *Automatic*

The phase indicated when first naming a species will be used to select a suitable reference concentration. The species must indicate the phase in the name when the species is first created.

For aqueous dilute species, denoted by (aq) in their names, the activity is calculated as their concentration divided by 1 M. For gaseous species, denoted by (g) in their names, the activity is calculated as their concentration divided by the standard reference pressure of 1 atm, converted into concentration using the ideal gas law. For solid species, denoted by (s) in their names, the reference concentration is 1. For surface species, denoted by (ads) in their names, the reference surface concentration will be set to the site density configured in the [Species Matching](#) section. Any species not containing a phase in their name, will use a reference state depending on the phase selected under [Mixture Properties](#). If the phase is Gas, the gaseous species reference concentration described above will be used, while if the phase is Liquid, the aqueous species 1 M reference concentration will be used.

### *User Defined*

The reference concentrations for each type of species can be set manually, for aqueous, gaseous, solid, surface, and any other species, respectively.

## ELECTRODE KINETICS

See the [Electrode Reaction](#) node in [Shared Physics Features in the Current Distribution Interfaces](#) for a general description of the Electrode Kinetics section.

Electrode reactions in the Chemistry interface support **User-defined**, **Butler–Volmer**, and **Linearized Butler–Volmer** kinetics. For the latter two options, **User-defined** exchange current densities and exchange current densities according to the **Mass Action Law** are supported.

If the equilibrium potential is calculated using **Nernst Equation**, the exponents in the local current density expression are evaluated using the reference overpotential. If

instead the equilibrium potential is calculated using the **Automatic** option, the exponents are evaluated using the overpotential.

### HEAT OF REACTION

See the [Electrode Reaction](#) node in [Shared Physics Features in the Current Distribution Interfaces](#) for a general description of the Heat of Reaction section.

Electrode Reactions in Chemistry do not support the **Temperature Derivative** option.

By choosing **Automatic**, the **Thermoneutral voltage** parameter,  $E_{\text{therm}}$  (SI unit: V), will be calculated according to

$$E_{\text{therm}} = -\frac{\Delta_r H}{nF} \quad (4-7)$$

using the [Species](#) enthalpies.



- [Electrode Reactions Theory](#)
  - [Electrode Kinetics Expressions](#)
- 

### *Electrode Reaction Group*

---

To add an **Electrode Reaction Group** node () either right-click the **Chemistry** node or in the **Chemistry** toolbar click **Electrode Reaction Group**.

An **Electrode Reaction Group** is typically used to represent all electrode reactions occurring on one electrode.

Multiple [Electrode Reaction](#) nodes may be added to the **Electrode Reaction Group**. Variables for the sum of all electrode reactions in one group can be used as input in **Electrode Reaction** features in current distribution interfaces.

This node is available with a Battery Design Module, Corrosion Module, Electrochemistry Module, Electrodeposition Module, or Fuel Cell & Electrolyzer Module license.

### *Reversible Reaction Group*

---







The **Reversible Reaction Group** node () allows input of a large number of reversible reactions in the same table. All reactions are treated in the same way. More than one Reversible Reaction Group can be added to a component.

Add the node from the **Chemistry** toolbar or right-click **Chemistry** and add it from the context menu.

For the case when reaction kinetics data are entered manually into the **Reaction table** and temperature-dependent reaction kinetics apply. The Enthalpy of Reaction (J/mol) can be calculated from the thermodynamics properties of the species.

### REACTION TABLE

The reversible reactions in the **Reaction table** are numbered and contain reactants, products, and kinetic parameters describing the reaction. Use the buttons under the **Reaction table** to add and sort the reaction details.

- In general, use the **Move Up** (  ), **Move Down** (  ), and **Delete** (  ) buttons and the fields under tables to edit the table contents. Or right-click a table cell and select **Move Up**, **Move Down**, or **Delete**.
- The **Add** button (  ) adds default reactant, A, and product, B, with a default. Click the corresponding field to edit the reactant, product, or parameters. After editing the **Species Group** node is also updated. It is created together with the reaction group.
- You can save the parameters to a text file to reuse in other models. Click the **Save to File** button (  ) and enter a **File name** in the **Save to File** dialog, including the extension .txt. Click **Save** to store the parameters in a text file or in a Microsoft Excel Workbook spreadsheet if the license includes LiveLink™ for Excel®. The information is saved in space-separated columns in the same order as displayed on screen. When saving to Excel, an **Excel Save** dialog appears where you can specify the sheet and range and whether to overwrite existing data or include a header.
- You can import or load data in files from a spreadsheet program, for example, with the **Load from File** button (  ) and the **Load from File** dialog that appears. Data must be separated by spaces or tabs. If there is already data in the table, imported parameters are added after the last row. Move or edit rows as needed. If the license includes LiveLink™ for Excel® you can also load parameters from a Microsoft Excel Workbook spreadsheet. Then an **Excel Load** dialog appears where you can specify the sheet and range and whether to overwrite existing data. It is also possible to import from a spreadsheet containing a separate column for units.

### CREATE REACTION AND SPECIES

Enter a reaction number in the **Moving reaction (with the number) from table** text field and click **Create Reaction** to remove the reaction from the **Reaction table** to the model tree. This introduces a reaction node named after the reaction number and species

names and simultaneously creates corresponding species nodes. This action is powerful, since it enables all the editing possibilities available for [Reaction](#) and [Species](#) nodes.

### *Equilibrium Reaction Group*







---

The **Equilibrium Reaction Group** node (  ) allows for input of a large number of equilibrium reactions in the same table. This node functions in the same way as the [Reversible Reaction Group](#) for reversible reactions.

Add the node from the **Chemistry** toolbar or right-click **Chemistry** and add it from the context menu.

#### **REACTION TABLE**

The equilibrium reactions in the table are numbered and contain reactants, products, and kinetic parameters describing the reaction. Use the buttons under the **Reaction table** to add and sort the reaction details.

- In general, use the **Move Up** (  ), **Move Down** (  ), and **Delete** (  ) buttons and the fields under tables to edit the table contents. Or right-click a table cell and select **Move Up**, **Move Down**, or **Delete**.
- The **Add** button (  ) adds default reactant, A, and product, B, with a default. Click the corresponding field to edit the reactant, product, or parameters. After editing the [Species Group](#) node is also updated. It is created together with the reaction group.
- You can save the parameters to a text file to reuse in other models. Click the **Save to File** button (  ) and enter a **File name** in the **Save to File** dialog, including the extension .txt. Click **Save** to store the parameters in a text file or in a Microsoft Excel Workbook spreadsheet if the license includes LiveLink™ for Excel®. The information is saved in space-separated columns in the same order as displayed on screen. When saving to Excel, an **Excel Save** dialog appears where you can specify the sheet and range and whether to overwrite existing data or include a header.
- You can import or load data in files from a spreadsheet program, for example, with the **Load from File** button (  ) and the **Load from File** dialog that appears. Data must be separated by spaces or tabs. If there is already data in the table, imported parameters are added after the last row. Move or edit rows as needed. If the license includes LiveLink™ for Excel® you can also load parameters from a Microsoft Excel Workbook spreadsheet. Then an **Excel Load** dialog appears where you can specify the

sheet and range and whether to overwrite existing data. It is also possible to import from a spreadsheet containing a separate column for units.

### *Species Group*

---

The **Species Group** node (  ) contains information on a molecular level about the volumetric species and the surface species present in the coupled reaction group features. The **Property for Volumetric Species** or **Property for Surface Species** tables typically collect parameters from when importing CHEMKIN transport files.

This node is automatically added when either the [Reversible Reaction Group](#) or the [Equilibrium Reaction Group](#) is used.

For the case of temperature-dependent reaction kinetics, a [Species Thermodynamics](#) subnode is automatically created in which the thermodynamic properties of the species can be specified.

### *Species Activity*

---

The **Species Activity** node (  ) creates variables for the activities of all the species/surface species present in the Species Group parent feature. Edit the **Activity coefficient** field in the **Species Activity** or **Surface Species Activity** tables by clicking in these.

**Species Activity** is a subnode to the [Species Group](#) node. It is automatically generated when nonideality in the fluid mixture is accounted for; when the **Use activity** checkbox is selected in the **Activity** section.



### *Species Thermodynamics*



---

The **Species Thermodynamics** node (  ) creates variables for the enthalpies, entropies, and heat capacities for all the species/surface species present in the [Species Group](#) parent feature. The purpose is to compute thermodynamic mixture properties and the heat of reactions.

This node is a subnode to the [Species Group](#) node.



# The Nernst–Planck–Poisson Equations Interface

The **Nernst–Planck–Poisson Equations** interface () , found under the **Chemical Species Transport** branch () when adding a physics interface, is a predefined multiphysics interface for modeling transport of electrolyte species without the otherwise common assumption of local electroneutrality. This allows for simulating charge separation that typically arises close to an electrode surface, where ions in the electrolyte are attracted and repelled by unscreened excess charge on the electrode. The charge separation region, also called the diffuse double layer, normally extends a few nanometers away from the electrode surface into the electrolyte. The study of the charge separation is important to applications that consider very thin layers of electrolyte, such as electrochemical capacitors, atmospheric corrosion problems, ion-selective field effect transistors (ISFETs), and nanoelectrochemistry.



The Nernst–Planck–Poisson Equations predefined multiphysics interface adds [The Transport of Diluted Species Interface](#) () (with Migration enabled), which solves for the Nernst–Planck equations without charge neutrality, and [The Electrostatics Interface](#) () , that solves for the Poisson’s equation.

A [Space Charge Density Coupling](#) () multiphysics node is also added. This node computes the local space charge, based on the local concentrations and species charges in the Transport of Diluted Species interface, and adds it to Poisson’s Equation in the Electrostatics interface.

Finally, a [Potential Coupling](#) () multiphysics node is added that applies the potential dependent variable in the Electrostatics interface into the migration term of the Transport of Diluted Species interface.

	<ul style="list-style-type: none"> <li>• <a href="#">The Multiphysics Branch</a> in the <i>COMSOL Multiphysics Reference Manual</i>.</li> <li>• <a href="#">The Transport of Diluted Species Interface</a></li> <li>• <a href="#">The Electrostatics Interface</a></li> <li>• <a href="#">Space Charge Density Coupling</a></li> <li>• <a href="#">Potential Coupling</a></li> </ul>
	<p><i>Diffuse Double Layer</i>: Application Library path  <b>Electrochemistry_Module/Tutorials/diffuse_double_layer</b></p>

# The Electrophoretic Transport Interface

The **Electrophoretic Transport (el)** interface () , found under the **Chemical Species Transport** branch () , is used to solve for the electrophoretic transport of an arbitrarily number of species in water-based system, subject to potential gradients. The species transported can be any combination of weak and strong acids and bases, ampholytes, and uncharged species. The transport of masses and charge is based on the Nernst–Planck equations for molecular transport, in combination with electroneutrality, dissociation equilibria for weak acids, bases, and ampholytes as well as the water autoionization reaction.

The physics interface can simulate most forms of electrophoresis modes, such as zone electrophoresis, isotachopheresis, isoelectric focusing, and moving boundary electrophoresis.

Gel electrophoresis can be simulated by the inclusion of immobile charged species.

The interface supports simulation in 1D, 2D, and 3D as well as for axisymmetric components in 1D and 2D.

The dependent variables are the electrolyte potential, and the molar concentrations of the included species, added individual by each species node in the model tree.



*Zone Electrophoresis:* Application Library path **Electrochemistry\_Module/**  
**Electrochemical\_Engineering/zone\_electrophoresis**

---

## SETTINGS

The **Label** is the default physics interface name.

The **Name** is used primarily as a scope prefix for variables defined by the physics interface. Refer to such physics interface variables in expressions using the pattern `<name>.<variable_name>`. In order to distinguish between variables belonging to different physics interfaces, the `name` string must be unique. Only letters, numbers, and underscores (`_`) are permitted in the **Name** field. The first character must be a letter.

The default **Name** (for the first physics interface in the model) is `e1`.

### DOMAIN SELECTION

If any part of the model geometry should not partake in the mass transfer model, remove that part from the selection list.

### OUT-OF-PLANE THICKNESS



For 2D components, enter a value or expression for the out-of-plane **Thickness**  $d$  (SI unit: m). The value of  $d$  determines the size of the domain perpendicular to the modeled 2D cross section. This value yields, for example, the correct total current when the current density is obtained from a 2D simulation.

### CROSS-SECTIONAL AREA



For 1D components, enter a **Cross-sectional area**  $A_c$  (SI unit:  $\text{m}^2$ ) to define a parameter for the area of the geometry perpendicular to the 1D component. The value of this parameter is used, among other things, to automatically calculate the total current from the current density vector. The analogy is valid for other fluxes. The default is  $1 \text{ m}^2$ .

### TRANSPORT MECHANISMS

Mass transport due to diffusion and migration is always included. Use the checkboxes available under **Additional transport mechanisms** to control other transport mechanisms.

- By default, the **Convection** checkbox is selected. Clear the checkbox to disable convective transport.
- The **Mass transfer in porous media** checkbox activates functionality specific to species transport in porous media. When selected, the Porous Matrix Properties node can be added to a domain to specify the electrolyte volume fraction and tortuosity, and the Effective Transport Parameter Correction sections are enabled in the species nodes.

## CONSISTENT STABILIZATION

To display this section, click the **Show More Options** button (  ) and select **Stabilization** in the **Show More Options** dialog.

- When the **Crosswind diffusion** checkbox is selected, a weak term that reduces spurious oscillations is added to the transport equation. The resulting equation system is always nonlinear.
- For both **Streamline diffusion** and **Crosswind diffusion**, select an **Equation residual**. **Approximate residual** is the default and means that derivatives of the diffusivity are neglected. This setting is usually accurate enough and is computationally faster. If required, select **Full residual** instead.

## INCONSISTENT STABILIZATION

To display this section, click the **Show More Options** button (  ) and select **Stabilization** in the **Show More Options** dialog. By default, the **Isotropic diffusion** checkbox is not selected because this type of stabilization adds artificial diffusion and affects the accuracy of the original problem. However, this option can be used to get a good initial guess for under-resolved problems.

## ADVANCED SETTINGS

To display this section, click the **Show More Options** button (  ) and select **Advanced Physics Options** in the **Show More Options** dialog. Normally these settings do not need to be changed. Select a **Convective term** — **Nonconservative form** (the default) or **Conservative form**. Use the conservative formulation for compressible flow.

## DISCRETIZATION

To display all settings available in this section, click the **Show More Options** button (  ) and select **Advanced Physics Options** in the **Show More Options** dialog.

The concentration variables are set to use Linear elements by default.

The potential variable is set to use Quadratic elements by default.

The **Compute boundary fluxes** checkbox is activated by default so that COMSOL Multiphysics computes predefined accurate boundary flux variables. When this option is selected, the solver computes variables storing accurate boundary fluxes from each boundary into the adjacent domain.

If the checkbox is cleared, the COMSOL Multiphysics software instead computes the flux variables from the dependent variables using extrapolation, which is less accurate

in postprocessing results but does not create extra dependent variables on the boundaries for the fluxes.

The flux variables affected in the interface are:

- `<name>.nI1`, where `<name>` is the name of the interface (default is `e1`), set on the interface top node. This is the normal electrolyte current density.
- `<name>.ntflux_<species_name>` is the **Species name** (see [Common Settings for the Species Nodes in the Electrophoretic Transport Interface](#) below). This is the normal total flux for each species.

Also the **Apply smoothing to boundary fluxes** checkbox is available if the previous checkbox is selected. The smoothing can provide a more well-behaved flux value close to singularities.

For details about the boundary fluxes settings, see [Computing Accurate Fluxes](#) in the *COMSOL Multiphysics Reference Manual*.

Regarding the **Value type when using splitting of complex variables**, see [Splitting Complex-Valued Variables](#) in the *COMSOL Multiphysics Reference Manual*.

#### DEPENDENT VARIABLES

The dependent variable name for the electrolyte potential variable is `phi1` by default.

The name of the concentration dependent variables are named as `e1.xxx`, where `e1` is the name of the interface as set above, and the `xxx` string is controlled by the **Species name** setting on the individual species nodes.

#### FURTHER READING



- [Theory for the Electrophoretic Transport Interface](#)
- [Numerical Stabilization](#) in the *COMSOL Multiphysics Reference Manual*.
- In the *COMSOL Multiphysics Reference Manual*, see [Table 2-4](#) for links to common sections and [Table 2-5](#) for common feature nodes. You can also search for information: press F1 to open the **Help** window or Ctrl+F1 to open the **Documentation** window.

## *Common Settings for the Species Nodes in the Electrophoretic Transport Interface*

---

The interface features the following species nodes, applicable on the domain level:

- [Ampholyte](#)
- [Fully Dissociated Species](#)
- [Uncharged Species](#)
- [Weak Acid](#)
- [Weak Base](#)

Each species node add a dependent variable for the concentration. The initial and boundary condition, as well as adding additional source reaction terms, for each species concentration is controlled by adding subnodes to the species nodes:

- [Concentration](#)
- [Flux](#)
- [Inflow](#)
- [Initial Concentration](#)
- [No Flux](#)
- [Outflow](#)
- [Species Source](#)

The [Ampholyte](#), [Weak Acid](#), and [Weak Base](#) nodes are dissociation species and may define an arbitrary number of dissociation steps. Each dissociation step is defined by its  $\text{p}K_a$  (the acid equilibrium constant) parameter. For the weak bases the  $\text{p}K_a$  refers to the acid constant of the conjugate acid. Each dissociation step adds one additional subspecies concentration variable so that the concentration dependent variable represents the sum of all subspecies, and initial and boundary conditions are defined with respect to this total concentration.

All species node have a setting for the **Species name**, which needs to be unique. The species name is used for naming of all related variables of the species. For species nodes not defining any subspecies, the concentration variables are named as `<name>.c_<species_name>` where `<name>` is the name of the interface (default is `e1`), set on the interface top node, and `<species_name>` is the **Species name**. For dissociation species nodes defining multiple subspecies, the concentration nodes are named as `<name>.c<X>_<species_name>` where `<X>` is the integer from 1 up to the

total number of subspecies. Note that the **Solvent** node automatically defines the concentration variables for protons (<name>.cH) and hydroxide ions (<name>.cOH).

All species except the **Uncharged Species** carry charge and contribute to the total electrolyte current which is used in the equation for solving the electrolyte potential.

The **Immobile Species** checkbox can be used to lock the concentration of a species, to, for instance, define the immobile charges in an ion-selective membrane or a gel. When the checkbox is enabled the concentration of the species is not added as a dependent variable to the model; instead the concentration will be set to the value provided in the **Concentration** field. The contribution to the electrolyte current for immobile species is zero.

### *Diffusion and Migration Settings*

---

All species, except when the **Immobile Species** checkbox has been enabled, may be transported by diffusion, and charged species are also transported by migration in the electric field.

For dissociation species you can choose to set the transport parameters to be the **Same for all species** appearing in the different dissociation steps, or you can use **Individual** settings for each subspecies.

Typically the mobilities and diffusivities for small species are related by the **Nernst–Einstein relation**, and when this relation is enabled you can choose whether to specify either the **Diffusivity** (SI unit:  $\text{m}^2/\text{s}$ ) or the **Mobility** (SI-unit:  $\text{s}\cdot\text{mol}/\text{kg}$ ). The **Debye–Hückel–Henry** relation is commonly used for larger molecules, such as proteins.

---

**Note:** There are other definitions of the migration transport equations in the literature which use mobilities expressed in  $\text{m}^2/(\text{V}\cdot\text{s})$ , whereas COMSOL Multiphysics uses  $\text{s}\cdot\text{mol}/\text{kg}$ . To convert mobilities expressed in  $\text{m}^2/(\text{V}\cdot\text{s})$  to the corresponding values in  $\text{s}\cdot\text{mol}/\text{kg}$ , you typically divide by the Faraday constant,  $F_{\text{const}}$  (about 96,485 C/mol).

---

### **EFFECTIVE TRANSPORT PARAMETER CORRECTION**

If **Mass transfer in porous media** is enabled on the interface top node, you can use the settings of this section in the species nodes to account for the changed mass transport in a porous domain due to the lowered porosity and the increased tortuosity.

The default correction model is **Bruggeman**, which multiplies the diffusivity and mobility values by the porosity to the power of 1.5. The porosity of a domain is set by the [Porous Matrix Properties](#) node.

### IONIC STRENGTH CONTRIBUTION

To display this section, click the **Show More Options** button (  ) and select **Advanced Physics Options** in the **Show More Options** dialog.

The **Debye–Hückel–Henry** relation makes use of the ionic strength for calculating the species mobility from the diffusivity. All charged species contribute to the ionic strength, either assuming the species contributing to an **Ideal solution** or by using the **Linderstrøm-Lang** assumption. The latter is usually used for macromolecules.

### *Domain, Boundary, and Pair Nodes for the Electrophoretic Transport Interface*

---

The interface has the following domain, boundary, and pair nodes, listed in alphabetical order, available from the **Physics** ribbon toolbar (Windows users), **Physics** context menu (Mac or Linux users), or by right-clicking to access the context menu (all users).



To add a node, go to the **Physics** toolbar, no matter what operating system you are using. Subnodes are available by clicking the parent node and selecting it from the **Attributes** menu.

---

- Ampholyte
- Concentration
- Current
- Current Density
- Current Source
- Flux
- Fully Dissociated Species
- Inflow
- Initial Concentration
- Initial Potential
- Insulation
- No Flux
- Outflow
- Porous Matrix Properties
- Potential
- Protein
- Species Source
- Solvent
- Uncharged Species
- Weak Acid
- Weak Base



For axisymmetric components, COMSOL Multiphysics takes the axial symmetry boundaries (at  $r = 0$ ) into account and automatically adds an **Axial Symmetry** node that is valid on boundaries representing the symmetry axis.



In the *COMSOL Multiphysics Reference Manual*, see [Table 2-4](#) for links to common sections and [Table 2-5](#) for common feature nodes. You can also search for information: press F1 to open the **Help** window or Ctrl+F1 to open the **Documentation** window.

### *Solvent*

The settings of this node are used to define the properties of the aqueous solvent.

If Convection is enabled on the interface top node, you can specify the **Velocity field** (m/s) as user defined input using analytical expressions or the velocity field variables solved for by a separate physics interface.

The Solvent node automatically defines the concentration variables and for protons ( $\langle \text{name} \rangle . \text{cH}$ ) and hydroxide ions ( $\langle \text{name} \rangle . \text{cOH}$ ), and the corresponding flux expressions. See [Diffusion and Migration Settings](#) for how to set up the transport parameters for the proton and hydroxide ions.

In the **Solvent Properties** section you can modify the **Dynamic viscosity** (Pa·s) and **Relative permittivity** (unitless) values. The **Built in** and default values are applicable to water. These parameters are used when calculating mobilities according to the **Debye–Hückel–Henry** relation in the species nodes.

In the **Water Self-Ionization** section you can change the default **Built in** expression for the **Water self-ionization constant**,  $pK_w$  (unitless), to any user-defined expression.

### *Porous Matrix Properties*

---

Use this node, available if **Mass transfer in porous media** has been enabled on the interface top-node, to define the **Porosity** (electrolyte volume fraction) and **Tortuosity** of a domain.

The porosity should be a number between 0 and 1.

### *Fully Dissociated Species*

---

Use this node to define a fully dissociated charged species, such as strong bases and acids.

The **Charge number**,  $Z_0$  (unitless), defines the species charge.

See also [Common Settings for the Species Nodes in the Electrophoretic Transport Interface](#) and [Diffusion and Migration Settings](#).

### *Uncharged Species*

---

Use this node to define a species that does not carry any charge, nor is impacted by the electric field.

See also [Common Settings for the Species Nodes in the Electrophoretic Transport Interface](#) and [Diffusion and Migration Settings](#).

### *Weak Acid*

---

The **Weak acid** node supports multiple dissociation steps, where the acid of the first dissociation step is uncharged.

The species can be either **Monoprotic**, subject to one dissociation step only, or **Polyprotic**. For the latter case, any positive integer larger than one can be used to define the **Number of dissociation steps**.

See also [Common Settings for the Species Nodes in the Electrophoretic Transport Interface](#) and [Diffusion and Migration Settings](#).

### *Weak Base*

---

The **Weak base** node supports multiple dissociation steps, where the base of the last dissociation step is uncharged.

The species can be either **Monoprotic**, subject to one dissociation step only, or **Polyprotic**. For the latter case, any positive integer larger than one can be used to define the **Number of dissociation steps**.

Note that the  $\text{p}K_a$  refers to the acid constant of the conjugate acid of the weak base.

See also [Common Settings for the Species Nodes in the Electrophoretic Transport Interface](#) and [Diffusion and Migration Settings](#).

### *Ampholyte*

---

Use the **Ampholyte** node generically to define any species where the average charge depends on the pH of the solution. The **Dissociation model** may be based either on a set of **Equilibrium constants** or an **Average charge**.

When using the **Equilibrium constants** the **Base charge in last dissociation step**,  $Z_0$  (unitless), needs to be set and be defined as an integer.

The **Average charge**,  $\bar{Z}$  (unitless) parameter is typically a function of pH and may be added as an analytical function or an interpolation polynomial under **Definitions**. The average squared charge, used in the electrolyte potential equation, is calculated automatically based on  $\bar{Z}$ .

See also [Common Settings for the Species Nodes in the Electrophoretic Transport Interface](#) and [Diffusion and Migration Settings](#).

### *Protein*

---

Use the **Protein** node to define macromolecules. The features of the Protein node are similar to the [Ampholyte](#) node, but with the default settings applicable for larger molecules.

See also [Common Settings for the Species Nodes in the Electrophoretic Transport Interface](#) and [Diffusion and Migration Settings](#).

## *Current Source*

---

To make this node available, click the **Show More Options** button (  ) and select **Advanced Physics Options** in the **Show More Options** dialog.

Use this node to add a current source in a domain. A current source may appear in a domain in homogenized porous electrode modeling, but should normally not be used.

## *Initial Potential*

---

Use this node to specify the **Initial Value** of the electrolyte potential for the solver.

## *Current*

---

The **Current** boundary condition sets the total current or average current density over a boundary. It will set a constant electrolyte potential along the given boundary, which satisfies the current value setting.

This node is typically used to model electrode surfaces or boundaries facing an electrolyte reservoir (containing an electrode).

When using the **Total current** option in 1D or 2D, the boundary area is based either on the **Cross-sectional area** (1D) or the **Out-of-Plane thickness** (2D) properties, set on the physics interface top node.

## *Current Density*

---

Use the **Current Density** node to specify the current density distribution along a boundary.

This node is typically used to model electrode surfaces where the electrode kinetics depends on the electrolyte potential.

Note that using this node in 2D or 3D may result in an uneven potential distribution along the boundary. To mitigate such effects you can use the [Current](#) node instead.

## *Insulation*

---

The **Insulation** boundary condition describes the walls of a cell or the boundaries of the cell that do not face an electrode (or a reservoir containing an electrode). The boundary condition imposes the following equation:

$$\mathbf{i}_l \cdot \mathbf{n} = 0$$

### *Potential*

---

Add the **Potential** node on a boundary to set a fixed potential. This node is typically used to model electrode surfaces or boundaries facing an electrolyte reservoir.

The node sets the potential in the electrolyte,  $\phi_l$ , to be equal to the **Boundary electrolyte potential**,  $\phi_{l, \text{bnd}}$  (SI unit: V).

#### **CONSTRAINT SETTINGS**

To display this section, click the **Show More Options** button (  ) and select **Advanced Physics Options** in the **Show More Options** dialog.

### *Species Source*

---

To make this node available, click the **Show More Options** button (  ) and select **Advanced Physics Options** in the **Show More Options** dialog.

This node may be added as a subnode to any species node. See also [Common Settings for the Species Nodes in the Electrophoretic Transport Interface](#).

In order to account for consumption or production of species, for example in porous electrodes or as a result of reversible reactions, the **Species Source** node adds source terms expressions  $S$  (SI unit:  $\text{mol}/(\text{m}^3 \cdot \text{s})$ ) to the right-hand side of the transport equation of the parent species.

### *Initial Concentration*

---

This node may be added as a subnode to any species node. See also [Common Settings for the Species Nodes in the Electrophoretic Transport Interface](#).

This node specifies the initial value for the **Concentration**,  $c$  ( $\text{mol}/\text{m}^3$ ), of the parent species. This value serve as the initial condition for a transient simulation. The value also serves as a start guess for stationary problems.

You can use spatially dependent functions (such as smoothed step functions) available under **Definitions** when defining the **Concentration** expression to specify different concentrations in different parts of the geometry. You can also use additional **Initial Values** node and modify the **Selection** to set different values for different domains.

## *Concentration*

---

This node may be added as a subnode to any species node. See also [Common Settings for the Species Nodes in the Electrophoretic Transport Interface](#)

This condition node adds a boundary condition for the parent species concentration. Use the node to, for instance, specify the inlet concentration at the boundary facing an electrolyte reservoir.

## *No Flux*

---

This node may be added as a subnode to any species node. See also [Common Settings for the Species Nodes in the Electrophoretic Transport Interface](#).

This node is the default boundary condition on exterior boundaries. It represents boundaries where no mass flows in or out of the boundaries. Hence, the total flux is zero.

## *Flux*

---

This node may be added as a subnode to any species node. See also [Common Settings for the Species Nodes in the Electrophoretic Transport Interface](#).

This node can be used to specify the species inward flux across a boundary. The flux can represent a flux from or into a much larger surrounding environment, a phase change, or a flux due to chemical reactions.

### **INWARD FLUX**

Enter a value or expression for the species mass flux  $J_0$ . Use a minus sign when specifying a flux directed out of the system.

#### *External convection*

Set **Flux type** to **External convection** to prescribe a flux to or from an exterior domain (not modeled) assumed to include convection. The exterior can for example include a forced convection to control the temperature or to increase the mass transport. In this case the prescribed mass flux corresponds to

$$J_0 = k_c(c_b - c)$$

where  $k_c$  is a mass transfer coefficient and  $c_b$  is the bulk concentration, the typical concentration far into the surrounding exterior domain.

## *Inflow*

---

This node is available when you select the **Convection** checkbox on the physics interface **Settings** window.

Use this node to specify the species concentrations at an inlet boundary.

### **BOUNDARY CONDITION TYPE**

The option **Concentration constraint** constrains the concentration values on the boundary by the use of pointwise constraints. When using this option the boundary condition is identical to the [Concentration](#) node.

The other option, **Flux (Danckwerts)** can be more stable and fast to solve when high reaction rates are anticipated in the vicinity of the inlet. Oscillations on the solutions can also be avoided in such cases. The latter condition uses a flux boundary condition based on the velocity across the boundary and the concentration values.



## *Outflow*

---

Set this condition at outlets where species are transported out of the model domain by migration or fluid motion. It is assumed that migration and convection are the dominating transport mechanisms across outflow boundaries, and therefore that diffusive transport can be ignored; that is:

$$\mathbf{n} \cdot (-D\nabla c) = 0$$

# The Surface Reactions Interface

The **Surface Reactions (sr)** interface () , found under the **Chemical Species Transport** branch () when adding a physics interface, is used to model the chemical reactions of surface and bulk species on a boundary. Surface species can be transported in the tangential direction of the surface by Fick's law whereas bulk species are assumed to be immobile on the surface.

The physics interface supports simulation of surface reactions on boundaries in 1D, 2D, and 3D as well as for axisymmetric components in 1D and 2D. The dependent variables are the surface concentrations,  $c_{s,i}$  (SI unit: mol/m<sup>2</sup>) and the bulk concentrations,  $c_{b,i}$  (SI unit: mol/m<sup>2</sup>).

When this physics interface is added, these default nodes are also added to the **Model Builder** — **Surface Properties, No Flux**, and **Initial Values**. Then, from the **Physics** toolbar, add other nodes that implement, for example, boundary conditions. You can also right-click **Surface Reactions** to select physics features from the context menu.

## SETTINGS



The **Label** is the default physics interface name.



The **Name** is used primarily as a scope prefix for variables defined by the physics interface. Refer to such physics interface variables in expressions using the pattern <name>.<variable\_name>. In order to distinguish between variables belonging to different physics interfaces, the **name** string must be unique. Only letters, numbers, and underscores (\_) are permitted in the **Name** field. The first character must be a letter.

The default **Name** (for the first physics interface in the model) is **sr**.

## DEPENDENT VARIABLES

Add or remove species and also change the names of the dependent variables that represent the species concentrations. Note that the names can be changed but the names of fields and dependent variables must be unique within a model.

Enter the **Number of surface species**. Use the **Add Surface Concentration** () and **Remove Surface Concentration** () buttons as needed. The resulting **Surface (adsorbed) species concentrations**  $cs_1, cs_2, cs_3, \dots$  are then listed in the table.

Enter the **Number of bulk species**. Use the **Add Bulk Concentration** (  ) and **Remove Bulk Concentration** (  ) buttons as needed. The resulting **Bulk concentrations** cb1, cb2, cb3, ... are then listed in the table.

#### DISCRETIZATION

To display all settings available in this section, click the **Show More Options** button (  ) and select **Advanced Physics Options** in the **Show More Options** dialog.

#### CONSISTENT AND INCONSISTENT STABILIZATION

To display these sections, click the **Show More Options** button (  ) and select **Stabilization** in the **Show More Options** dialog.

By default the **Compensate for boundary stretching** checkbox is selected for the [Surface Properties](#) node. This section is then used to stabilize the tangential mesh velocity term.

When the **Compensate for boundary stretching** checkbox is cleared (not selected), and for fixed geometries or moving geometries, the stabilization has no effect.

See [Surface Reaction Equations on Deforming Geometries](#) for more information.



- [Boundary, Edge, Point, and Pair Nodes for the Surface Reactions Interface](#)
  - [Theory for the Surface Reactions Interface](#)
- 

#### *Boundary, Edge, Point, and Pair Nodes for the Surface Reactions Interface*

---

The [Surface Reactions Interface](#) has these boundary, edge, point, and pair nodes, listed in alphabetical order, available from the **Physics** ribbon toolbar (Windows users), **Physics** context menu (Mac or Linux users), or right-click to access the context menu (all users).



In general, to add a node, go to the **Physics** toolbar, no matter what operating system you are using. Subnodes are available by clicking the parent node and selecting it from the **Attributes** menu.

---

These nodes are described in this section:

- [Initial Values](#)
- [Reactions](#)
- [Surface Concentration](#)
- [Surface Properties](#)

All other available nodes are described for the Transport of Diluted Species interface. See [Domain, Boundary, and Pair Nodes for the Transport of Diluted Species Interface](#).



In the *COMSOL Multiphysics Reference Manual* see [Table 2-4](#) for links to common sections and [Table 2-5](#) to common feature nodes. You can also search for information: press F1 to open the **Help** window or Ctrl+F1 to open the **Documentation** window.

---

### *Surface Properties*

---

Use the **Surface Properties** node to define the density of sites, the site occupancy number, and the surface diffusion.

#### **SPECIES CONSERVATION ON DEFORMING GEOMETRY**

The **Compensate for boundary stretching** checkbox is selected by default. Click to clear the checkbox if required.

#### **SITES**

Enter a value or expression for the **Density of sites**  $\Gamma_s$  (SI unit: mol/m<sup>2</sup>). The default is  $2 \times 10^{-5}$  mol/m<sup>2</sup>.

Enter a **Site occupancy number**  $\sigma_i$  (dimensionless), indicating how many surface sites a surface species block upon adsorption.

This section is only present if the number of surface species is 1 or higher.

#### **SURFACE DIFFUSION**

Select a **Surface material** from the list. The default is **None**.

For each surface concentration species, the default **Diffusion coefficient**  $D_1$  (SI unit: m<sup>2</sup>/s) is **User defined**. Select **Isotropic**, **Diagonal**, **Symmetric**, or **Full** depending on the characteristics of the surface, and then enter values or expressions in the field or matrix.

This section is only present if the number of surface species is 1 or higher.

## BULK SPECIES

For each bulk species enter the **Molar mass**  $M_i$  (SI unit: kg/mol) and the **Density**  $\rho_i$  (SI unit: kg/m<sup>3</sup>). The default molar mass is 0.144 kg/mol and the default density is 5320 kg/m<sup>3</sup>.

This section is only present if the number of bulk species is 1 or higher.



## Surface Reaction Equations on Deforming Geometries

---

### *Initial Values*

---

The **Initial Values** node allows the initial value or guess for the surface and bulk concentrations.

#### INITIAL VALUES

Based on the number of surface species and number of bulk species entered for the physics interface under Dependent Variables section, enter values for the same number of **Surface concentration**  $cs$ ,  $cs2$ ,  $cs3$ , ... (SI unit: mol/m<sup>2</sup>) and **Bulk concentration**  $cb$ ,  $cb2$ ,  $cb3$ , ... (SI unit: mol/m<sup>2</sup>) in each field.

### *Reactions*

---

The **Reactions** node adds rate expression terms to the species transport equations in order to account for consumption or production of species due to reactions.

#### REACTION RATE FOR SURFACE SPECIES

Add a reaction rate expression,  $R_{s,cs1,cs2...}$  (SI unit: mol/(m<sup>2</sup>·s)), for each surface species taking part in a surface reaction.

This section is only present if the number of surface species is 1 or higher.

#### REACTION RATE FOR BULK SPECIES

Add a reaction rate expression,  $R_{b,cb1,cb2...}$  (SI unit: mol/(m<sup>2</sup>·s)), for each bulk species taking part in a surface reaction.

This section is only present if the number of bulk species is 1 or higher.

## *Surface Concentration*

---

Use the **Surface Concentration** node to set the surface concentrations for one or more species on an edge (3D components) or a point (2D and 2D axisymmetric components).

### **SURFACE CONCENTRATION**

Select each species checkbox as needed and enter a value or expression for each species concentration,  $c_{s,0}, c_{s1}, c_{s2}, \dots$  (SI unit:  $\text{mol}/(\text{m}^2 \cdot \text{s})$ ).

### **CONSTRAINT SETTINGS**

To display this section, click the **Show More Options** button (  ) and select **Advanced Physics Options** in the **Show More Options** dialog.

# Theory for the Transport of Diluted Species Interface

The [Transport of Diluted Species Interface](#) provides a predefined modeling environment for studying the evolution of chemical species transported by diffusion and convection as well as migration due to an electric field. The physics interface assumes that all species present are dilute; that is, that their concentration is low compared to a solvent fluid or solid. As a rule of thumb, a mixture containing several species can be considered dilute when the concentration of the solvent is more than 90 mol%. Due to the dilution, mixture properties such as density and viscosity can be assumed to correspond to those of the solvent.

When studying mixtures that are not dilute, the mixture and transport properties depend on the composition, and a different physics interface is recommended. See [The Transport of Concentrated Species Interface](#) in the *Chemical Reaction Engineering Module User's Guide* for more information.

*Fick's law* governs the diffusion of the solutes, dilute mixtures, or solutions, while the phenomenon of ionic migration is sometimes referred to as *electrokinetic flow*. The Transport of Diluted Species interface supports the simulations of chemical species transport by convection, migration, and diffusion in 1D, 2D, and 3D as well as for axisymmetric components in 1D and 2D.

In this section:

- [Adding Transport Through Migration](#)
- [Material Balance Formulation](#)
- [Crosswind Diffusion](#)
- [Danckwerts Inflow Boundary Condition](#)
- [Equilibrium Reaction Theory](#)
- [Mass Balance Equation](#)
- [Mass Sources for Species Transport](#)
- [Solving a Diffusion Equation Only](#)
- [Supporting Electrolytes](#)
- [References](#)

Note: Some features explained in this section require certain add-on modules. For details see [www.comsol.com/products/specifications/](http://www.comsol.com/products/specifications/)

The section also includes the theory for [The Transport of Diluted Species in Porous Media Interface](#):

- [Adsorption](#)
- [Convection in Porous Media](#)
- [Diffusion in Porous Media](#)
- [Dispersion](#)
- [Mass Balance Equation for Transport of Diluted Species in Porous Media](#)
- [Mass Transport in Fractures](#)
- [Reactions](#)

### *Mass Balance Equation*

---

The default node attributed to the Transport of Diluted Species interface models chemical species transport through diffusion and convection and solves the mass conservation equation for one or more chemical species  $i$ :

$$\frac{\partial c_i}{\partial t} + \nabla \cdot \mathbf{J}_i + \mathbf{u} \cdot \nabla c_i = R_i \quad (4-8)$$

[Equation 4-8](#) in its form above includes the transport mechanisms diffusion and convection. If *Migration in Electric Field* is activated (only available in some add-on products), the migration mechanism will be added to the equation as well. See more details in the section [Adding Transport Through Migration](#).

- $c_i$  is the concentration of the species (SI unit: mol/m<sup>3</sup>)
- $D_i$  denotes the diffusion coefficient (SI unit: m<sup>2</sup>/s)
- $R_i$  is a reaction rate expression for the species (SI unit: mol/(m<sup>3</sup>·s))
- $\mathbf{u}$  is the mass averaged velocity vector (SI unit: m/s)
- $\mathbf{J}_i$  is the mass flux diffusive flux vector (SI unit: mol/(m<sup>2</sup>·s))

The mass flux relative to the mass averaged velocity,  $\mathbf{J}_i$  (SI unit: mol/(m<sup>2</sup>·s)), is associated with the mass balance equation above and used in boundary conditions and flux computations. The Transport of Diluted Species interface always includes mass transport due to molecular diffusion. In this case the mass flux  $\mathbf{J}_i$  defines the diffusive flux vector

$$\mathbf{J}_i = -D\nabla c_i \quad (4-9)$$

An input field for the diffusion coefficient is available.

When *Migration in Electric Fields* is activated, the migration term is also added to the diffusive flux vector as shown in the section [Adding Transport Through Migration](#).

The third term on the left side of [Equation 4-8](#) describes the convective transport due to a velocity field  $\mathbf{u}$ . This field can be expressed analytically or obtained from coupling the physics interface to one that solves for fluid flow, such as *Laminar Flow*. Note that all fluid flow interfaces solve for the mass averaged velocity.

On the right-hand side of the mass balance equation ([Equation 4-8](#)),  $R_i$  represents a source or sink term, typically due to a chemical reaction or desorption on a porous matrix. To specify  $R_i$ , another node must be added to the Transport of Diluted Species interface — the **Reaction** node for example, which includes an input field for specifying a reaction expression using the variable names of all participating species.

### *Equilibrium Reaction Theory*

---

The feature Equilibrium Reaction is described in this section. A chemical equilibrium reaction system is defined by the stoichiometry of the reaction and the relation between the chemical activities of the chemical species participating in the reaction (the equilibrium condition).

The kinetics of the reaction is so fast that the equilibrium condition is fulfilled at all times in all space coordinates.

The equilibrium condition is commonly based on the stoichiometric coefficients,  $\nu_i$  (dimensionless), of the reaction; the species activities of the reacting species  $a_i$  (dimensionless); and an equilibrium constant,  $K_{\text{eq}}$  (1) according to

$$K_{\text{eq}} = \frac{\prod_{i \in \text{products}} a_i^{\nu_i}}{\prod_{i \in \text{reactants}} a_i^{-\nu_i}}$$

where the species activities are defined as

$$a_i = \gamma_{c,i} \frac{c_i}{c_{a0}}$$

where  $c_{a0}$  (SI unit: mol/m<sup>3</sup>) is the standard molarity, and  $\gamma_{c,i}$  (dimensionless) an activity coefficient.

Defining the stoichiometric coefficients positive for products and negative for reactants, the above equilibrium condition can also be written

$$K_{\text{eq}} = \prod_i a_i^{v_i}$$

The **Equilibrium Reaction** node solves for a reaction rate so that the equilibrium condition is always fulfilled in the domain. It is available for the Chemical Reaction Engineering Module; Battery Design Module; Corrosion Module; Electrochemistry Module; Electrodeposition Module; and Fuel Cell & Electrolyzer Module.



$\gamma_{e,i}$  is set to unity when the Equilibrium constant is selected in the Settings window. For nonunity activity coefficients, a user-defined equilibrium condition can be used.

#### **EQUILIBRIUM REACTIONS AND INFLOW BOUNDARY CONDITIONS**

Contradictory constraints arise if the boundary conditions for concentrations or activities are set so that the domain equilibrium condition is not fulfilled. Special treatment is therefore needed at Inflow boundaries, where the concentrations are set for all species in the mass transport interfaces.

One way of avoiding competing constraints on an inflow boundary is to add an additional reaction coordinate degree of freedom, solved for to create a set of modified inflow concentrations that fulfill the domain equilibrium condition. The reaction coordinate gives rise to a concentration shift, which is the offset to the inflow concentrations provided by the user. The shift for each species obeys the stoichiometry of the reaction and the equilibrium expression. The modified inflow concentrations are then used in the boundary conditions for the domain mass transport equations. The resulting modified inflow concentrations can be seen as the stationary solution for a batch reactor with the user inflow concentrations as initial concentrations. In addition, the domain reaction rate degree of freedom of the equilibrium reaction is constrained to zero on all Inflow boundaries.

#### **EQUILIBRIUM REACTIONS AND CONCENTRATION BOUNDARY CONDITIONS**

No special treatment is made with regards to input concentration values of the Concentration boundary node. Using this feature, you can explicitly set one or a set of concentrations, and the equilibrium condition acts on the rest of the concentrations.

However, there is no solution to the problem if more concentrations than the number of species minus the number of equilibrium reactions are set using this feature.

### EQUILIBRIUM REACTIONS AND TIME-DEPENDENT SIMULATIONS

Spurious oscillations may occur in a time-dependent problem if the initial conditions do not fulfill the equilibrium condition. Since equilibrium reactions are assumed to be infinitely fast, the solution is to initialize the problem using an additional study step, solving for a stationary problem with all nonequilibrium reaction rates set to zero. Manual scaling of the reaction rate dependent variables is needed in this study step.

#### *Material Balance Formulation*

---

The default node attributed to [The Transport of Diluted Species Interface](#) assumes chemical species transport through diffusion and convection (depending on the modules licensed, a checkbox to activate migration is available) and implements the mass balance equation in [Equation 4-8](#).

Two formulations of the mass balance are available, these are referred to as the nonconservative and conservative form:

$$\text{nonconservative: } \frac{\partial c}{\partial t} + \nabla \cdot \mathbf{J}_i + \mathbf{u} \cdot \nabla c = R \quad (4-10)$$

$$\text{conservative: } \frac{\partial c}{\partial t} + \nabla \cdot \mathbf{J}_i + \nabla \cdot (c\mathbf{u}) = R \quad (4-11)$$

In these equations  $\mathbf{J}_i$  is the diffusive flux vector,  $\mathbf{u}$  is the solvent velocity field, and  $R$  is a production or consumption rate expression. The nonconservative is often more numerically robust, and therefore chosen by default for the interface. This formulation however disregards density changes in the fluid. This can be seen by expanding the conservative convection term using the chain rule. One of the resulting terms,  $c\nabla \cdot \mathbf{u}$ , equals zero for an incompressible fluid which results in the nonconservative form. To switch between the two formulations, click the **Show** button (  ) and select **Advanced Physics Options**.

#### *Solving a Diffusion Equation Only*

---

Remove the convection term from [Equation 4-10](#) and [Equation 4-11](#) by clearing the Convection checkbox in the Transport Mechanisms section for [The Transport of Diluted Species Interface](#). The equation then becomes

$$\frac{\partial c}{\partial t} = \nabla \cdot \mathbf{J}_i + R$$

### *Mass Sources for Species Transport*

---

**Note:** The features below are only available in a limited set of add-on products. For a detailed overview of which features are available in each product, visit [www.comsol.com/products/specifications/](http://www.comsol.com/products/specifications/)

---

There are two types of mass sources in the Transport of Diluted Species interface: point sources and line sources.

#### **POINT SOURCE**

A point source is theoretically formed by assuming a mass injection/ejection,  $Q_c$  (SI unit: mol/(m<sup>3</sup>·s)), in a small volume  $\delta V$  and then letting the size of the volume tend to zero while keeping the total mass flux constant. Given a point source strength,  $\dot{q}_{p,c}$  (SI unit: mol/s), this can be expressed as

$$\lim_{\delta V \rightarrow 0} \int_{\delta V} Q_c = \dot{q}_{p,c} \quad (4-12)$$

An alternative way to form a point source is to assume that mass is injected/extracted through the surface of a small object. Letting the object surface area tend to zero while keeping the mass flux constant results in the same point source. For this alternative approach, effects resulting from the physical object's volume need to be neglected.

The weak contribution

$$\dot{q}_{p,c} \text{test}(c)$$

is added at a point in the geometry. As can be seen from Equation 4-12,  $Q_c$  must tend to plus or minus infinity as  $\delta V$  tends to zero. This means that in theory the concentration also tends to plus or minus infinity.

Observe that “point” refers to the physical representation of the source. A point source can therefore only be added to points in 3D components and to points on the symmetry axis in 2D axisymmetry components. Other geometrical points in 2D components represent physical lines.

The finite element representation of Equation 4-12 corresponds to a finite concentration at a point with the effect of the point source spread out over a region around the point. The size of the region depends on the mesh and on the strength of the source. A finer mesh gives a smaller affected region but also a more extreme concentration value. It is important not to mesh too finely around a point source since this can result in unphysical concentration values. It can also have a negative effect on the condition number for the equation system.

### LINE SOURCE

A line source can theoretically be formed by assuming a source of strength  $Q_{1,c}$  (SI unit:  $\text{mol}/(\text{m}^3 \cdot \text{s})$ ), located within a tube with cross section  $\delta S$  and then letting  $\delta S$  tend to zero while keeping the total mass flux per unit length constant. Given a line source strength,  $\dot{q}_{1,c}$  (SI unit:  $\text{mol}/(\text{m} \cdot \text{s})$ ), this can be expressed as

$$\lim_{\delta S \rightarrow 0} \int_{\delta S} Q_{1,c} = \dot{q}_{1,c} \quad (4-13)$$

As in the point source case, an alternative approach is to assume that mass is injected/extracted through the surface of a small object. This results in the same mass source, but requires that effects resulting from the physical object's volume are neglected.

The weak contribution

$$q_{1,c}^{\text{test}(c)}$$

is added on lines in 3D or at points in 2D (which represent cut-through views of lines). Line sources can also be added on the axisymmetry line in 2D axisymmetry components. It cannot, however, be added on geometrical lines in 2D since those represent physical planes.

As with a point source, it is important not to mesh too finely around the line source.



For feature node information, see [Line Mass Source](#) and [Point Mass Source](#).

---

**Note:** Migration is only available in a limited set of add-on products. For a detailed overview of which features are available in each product, visit [www.comsol.com/products/specifications/](http://www.comsol.com/products/specifications/)

---

In addition to transport due to convection and diffusion, the Transport of Diluted Species interface supports ionic species transport by *migration*. This is done by selecting the Migration in Electric Field checkbox under the Transport Mechanisms section for the physics interface. The mass balance then becomes:

$$\frac{\partial c_i}{\partial t} + \nabla \cdot (-D_i \nabla c_i - z_i u_{m,i} F c_i \nabla V + c_i \mathbf{u}) = R_i \quad (4-14)$$

where

- $c_i$  (SI unit: mol/m<sup>3</sup>) denotes the concentration of species  $i$
- $D_i$  (SI unit: m<sup>2</sup>/s) is the diffusion coefficient of species  $i$
- $\mathbf{u}$  (SI unit: m/s) is the fluid velocity
- $F$  (SI unit: A·s/mol) refers to Faraday's constant
- $V$  (SI unit: V) denotes the electric potential
- $z_i$  (dimensionless) is the charge number of the ionic species, and
- $u_{m,i}$  (SI unit: mol·s/kg) is its ionic mobility

In this case the diffusive flux vector is

$$\mathbf{J}_i = -D_i \nabla c_i - z_i u_{m,i} F c_i \nabla V$$

The velocity,  $\mathbf{u}$ , can be a computed fluid velocity field from a Fluid Flow interface or a specified function of the spatial variables  $x$ ,  $y$ , and  $z$ . The potential can be provided by an expression or by coupling the system of equations to a current balance, such as the Electrostatics interface. Sometimes it is assumed to be a supporting electrolyte present, which simplifies the transport equations. In that case, the modeled charged species concentration is very low compared to other ions dissolved in the solution. Thus, the species concentration does not influence the solution's conductivity and the net charge within the fluid.

The Nernst–Einstein relation can in many cases be used for relating the species mobility to the species diffusivity according to

$$u_{m,i} = \frac{D_i}{RT}$$

where  $R$  (SI unit: J/(mol·K)) is the molar gas constant and  $T$  (SI unit: K) is the temperature.

---

**Note:** In the *Nernst–Planck Equations* interface, the ionic species contribute to the charge transfer in the solution. It includes an *electroneutrality condition* and also computes the electric potential field in the electrolyte. For more information, see [Theory for the Nernst–Planck Equations Interface](#). This interface is included in the Chemical Reaction Engineering Module.

---

### *Supporting Electrolytes*

---

In *electrolyte* solutions, a salt can be added to provide a high electrolyte conductivity and decrease the ohmic losses in a cell. These solutions are often called *supporting electrolytes*, buffer solutions, or carrier electrolytes. The added species, a negative and a positive ion pair, predominates over all other species. Therefore, the supporting electrolyte species can be assumed to dominate the current transport in the solution. In addition, the predominant supporting ions are usually selected so that they do not react at the electrode surfaces since the high conductivity should be kept through the process, that is, they should not be electroactive species. This also means that the concentration gradients of the predominant species in a supporting electrolyte are usually negligible.

Modeling and solving for a supporting electrolyte in the *Electrostatics* or *Secondary Current Distribution* interfaces will give a potential distribution that drives the migration in the Transport of Diluted Species Interface.

The current density vector is proportional to the sum of all species fluxes as expressed by Faraday’s law:

$$\mathbf{i} = F \sum_i z_i \mathbf{N}_i$$

The electroneutrality condition ensures that there is always a zero net charge at any position in a dilute solution. Intuitively, this means that it is impossible to create a current by manually pumping positive ions in one direction and negative ions in the other. Therefore, the convective term is canceled out to yield the following expression for the electrolyte current density, where  $j$  denotes the supporting species:

$$\mathbf{i} = F \sum_j -z_j^2 u_{m,j} F c_j \nabla \phi \quad (4-15)$$

Equation 4-15 is simply Ohm's law for ionic current transport and can be simplified to

$$\mathbf{i} = -\kappa \nabla \phi \quad (4-16)$$

where  $\kappa$  is the conductivity of the supporting electrolyte. A current balance gives the current and potential density in the cell

$$\nabla \cdot \mathbf{i} = 0$$

which, in combination with Equation 4-16, yields:

$$\nabla \cdot (-\kappa \nabla \phi) = 0 \quad (4-17)$$

Equation 4-17 can be easily solved using the Electrostatics or Secondary Current Distribution interface and, when coupled to the Transport in Diluted Species interface, the potential distribution shows up in the migration term.

### *Crosswind Diffusion*

---

Transport of diluted species applications can often result in models with a very high cell Péclet number — that is, systems where convection or migration dominates over diffusion. Streamline diffusion and crosswind diffusion are of paramount importance to obtain physically reasonable results. The Transport of Diluted Species interface provides two crosswind diffusion options using different formulations. Observe that crosswind diffusion makes the equation system nonlinear even if the transport equation is linear.

#### **DO CARMO AND GALEÃO**

This is the formulation described in [Numerical Stabilization](#) in the *COMSOL Multiphysics Reference Manual*. The method reduces over- and undershoots to a minimum, even for anisotropic meshes.

In some cases, the resulting nonlinear equation system can be difficult to converge. This can happen when the cell Péclet number is very high and the model contains many thin layers, such as contact discontinuities. You then have three options:

- Refine the mesh, especially in regions with thin layers.
- Use a nonlinear solver with a constant damping factor less than one.
- Switch to the Codina crosswind formulation.

#### **CODINA**

The Codina formulation is described in [Ref. 1](#). It adds diffusion strictly in the direction orthogonal to the streamline direction. Compared to the do Carmo and Galeão formulation, the Codina formulation adds less diffusion but is not as efficient at reducing over- and undershoots. It also does not work as well for anisotropic meshes. The advantage is that the resulting nonlinear system is easier to converge and that underresolved gradients are less smeared out.

#### *Danckwerts Inflow Boundary Condition*

---

Constraining the composition to fixed values at an inlet to a reactor may sometimes result in issues with unreasonably high reaction rates or singularities at the inlet boundary. These problems may many times be mitigated by using a flux boundary condition instead, based on the upstream concentrations and the fluid velocity at the boundary. In chemical engineering, this type of flux boundary condition is also known as a Danckwerts condition.

Use the Danckwerts condition to specify inlet conditions for domains where high reaction rates are anticipated in the vicinity to the inlet ([Ref. 2](#)).

Given an upstream concentration  $c_{i,0}$ , the Danckwerts inflow boundary condition prescribed the total flux as

$$\mathbf{n} \cdot (\mathbf{J}_i + \mathbf{u}c_i) = \mathbf{n} \cdot (\mathbf{u}c_{i,0}) \quad (4-18)$$

**VARIABLY SATURATED POROUS MEDIA**

The following equations for the molar concentrations,  $c_i$ , describe the transport of solutes in a variably saturated porous medium for the most general case, when the pore space is primarily filled with liquid but also contain pockets or immobile gas:

$$\frac{\partial}{\partial t}(\theta_l c_i) + \frac{\partial}{\partial t}(\rho c_{p,i}) + \frac{\partial}{\partial t}(\theta_g c_{g,i}) + \mathbf{u} \cdot \nabla c_i = \nabla \cdot [(D_{D,i} + D_{e,i})\nabla c_i] + R_i + S_i \quad (4-19)$$

On the left-hand side of Equation 4-19, the first three terms correspond to the accumulation of species within the liquid, solid, and gas phases, while the last term describes the convection due to the velocity field  $\mathbf{u}$  (SI unit: m/s).

In Equation 4-19  $c_i$  denotes the concentration of species  $i$  in the liquid (SI unit: mol/m<sup>3</sup>),  $c_{p,i}$  the amount adsorbed to solid particles (moles per unit dry weight of the solid), and  $c_{g,i}$  the concentration of species  $i$  in the gas phase.

The equation balances the mass transport throughout the porous medium using the porosity  $\epsilon_p$ , the liquid volume fraction  $\theta_l$ ; the dry bulk density,  $\rho = (1 - \epsilon_p)\rho_s$ , and the solid phase density  $\rho_s$ .

For saturated porous media, the liquid volume fraction  $\theta_l$  is equal to the porosity  $\epsilon_p$ , but for unsaturated porous media, they are related by the saturation  $s$  as  $\theta_l = \epsilon_p s$ . The resulting gas volume fraction in the case of an unsaturated porous medium is

$$\theta_g = \epsilon_p - \theta_l = (1 - s)\epsilon_p$$

On the right-hand side of Equation 4-19, the first term introduces the spreading of species due to mechanical mixing resulting from the porous media (dispersion), as well as from diffusion and volatilization to the gas phase. The dispersion tensor is denoted  $D_D$  (SI unit: m<sup>2</sup>/s) and the effective diffusion by  $D_e$  (SI unit: m<sup>2</sup>/s).

The last two terms on the right-hand side of Equation 4-19 describe production or consumption of the species;  $R_i$  is a reaction rate expression which can account for reactions in the liquid, solid, or gas phase, and  $S_i$  is an arbitrary source term, for example due to a fluid flow source or sink.

### Adsorption

The time evolution of the adsorption, the solute transport to or from the solid phase, is defined by assuming that the amount of solute adsorbed to the solid,  $c_{P,i}$ , is a function of the concentration in the fluid  $c_i$ . This implies that the solute concentration in the liquid and solid phase are in instant equilibrium. The adsorption term can be expanded to give

$$\frac{\partial}{\partial t}(\rho c_{P,i}) = \rho \frac{\partial c_{P,i}}{\partial c_i} \frac{\partial c_i}{\partial t} - c_{P,i} \rho_s \frac{\partial \epsilon_P}{\partial t} = \rho K_{P,i} \frac{\partial c_i}{\partial t} - c_{P,i} \rho_s \frac{\partial \epsilon_P}{\partial t} \quad (4-20)$$

where  $K_{P,i} = \partial c_{P,i} / \partial c_i$  is the adsorption isotherm.

### Volatilization

Volatilization is the process where a solute species in the liquid is transported to the gas phase due to vaporization. Assuming that the amount of solute in the gas phase,  $c_{G,i}$ , is a linear function of the liquid phase concentration, the volatilization term is defined as

$$\frac{\partial}{\partial t} \theta_g c_{G,i} = \theta_g \frac{\partial c_{G,i}}{\partial c_i} \frac{\partial c_i}{\partial t} + k_{G,i} c_i \frac{\partial \theta_g}{\partial t} = \theta_g k_{G,i} \frac{\partial c_i}{\partial t} + k_{G,i} c_i \frac{\partial \theta_g}{\partial t} \quad (4-21)$$

where  $k_{G,i} = \partial c_{G,i} / \partial c_i$  is the linear volatilization.

## SATURATED POROUS MEDIA

In the case of transport in a saturated porous medium,  $\theta_1 = \epsilon_p$ , and the governing equations are

$$\frac{\partial}{\partial t}(\epsilon_p c_i) + \frac{\partial}{\partial t}(\rho c_{P,i}) + \mathbf{u} \cdot \nabla c_i = \nabla \cdot [(D_{D,i} + D_{e,i}) \nabla c_i] + R_i + S_i \quad (4-22)$$

### Convection in Porous Media

---

Convection (also called advection) describes the movement of a species, such as a pollutant, with the bulk fluid velocity. The velocity field  $\mathbf{u}$  corresponds to a superficial volume average over a unit volume of the porous medium, including both pores and matrix. This velocity is sometimes called *Darcy velocity*, and defined as volume flow

rates per unit cross section of the medium. This definition makes the velocity field continuous across the boundaries between porous regions and regions with free flow.



The velocity field to be used in the Model Inputs section on the physics interface can, for example, be prescribed using the velocity field from a Darcy's Law or a Brinkman Equations interface.

The average linear fluid velocities  $\mathbf{u}_a$ , provides an estimate of the fluid velocity within the pores:

$$\mathbf{u}_a = \frac{\mathbf{u}}{\varepsilon_p} \quad \text{Saturated}$$

$$\mathbf{u}_a = \frac{\mathbf{u}}{\theta_l} \quad \text{Unsaturated}$$

where  $\varepsilon_p$  is the porosity and  $\theta_l = s\varepsilon_p$  the liquid volume fraction, and  $s$  the saturation, a dimensionless number between 0 and 1.

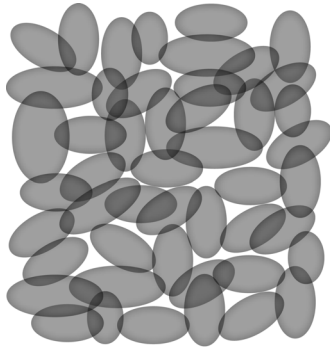

*Figure 4-3: A block of a porous medium consisting of solids and the pore space between the solid grains. The average linear velocity describes how fast the fluid moves within the pores. The Darcy velocity attributes this flow over the entire fluid-solid face.*

#### **MATERIAL BALANCE FORMULATION**

The Transport of Diluted Species interface in porous media includes two formulations of the material balance. The conservative formulation of the species equations in [Equation 4-19](#) is written as:

$$\frac{\partial}{\partial t}(\theta_l c_i) + \frac{\partial}{\partial t}(\rho c_{p,i}) + \frac{\partial}{\partial t}(\theta_g c_{g,i}) + \nabla \cdot \mathbf{u} c_i = \nabla \cdot [(D_{D,i} + D_{e,i}) \nabla c_i] + R_i + S_i \quad (4-23)$$

If the conservative formulation is expanded using the chain rule, then one of the terms from the convection part,  $c_i \nabla \cdot \mathbf{u}$ , would equal zero for an incompressible fluid and would result in the nonconservative formulation described in [Equation 4-19](#).

When using the nonconservative formulation, which is the default, the fluid is assumed incompressible and divergence free:  $\nabla \cdot \mathbf{u} = 0$ . The nonconservative formulation improves the stability of systems coupled to a momentum equation (fluid flow equation).



To switch between the two formulations, click the **Show** button (  ) and select **Advanced Physics Options**. In the section **Advanced Settings** select either **Nonconservative** (the default) or **Conservative**. The conservative formulation should be used for compressible flow.

### *Diffusion in Porous Media*

The effective diffusion in porous media,  $D_e$ , depends on the structure of the porous material and the phases involved. Dependent on whether the transport of diluted species occurs in free flow or in saturated or unsaturated porous media, the effective diffusivity is defined as:

$$\begin{aligned} D_e &= D_F && \text{Free Flow} \\ D_e &= \frac{\epsilon_p}{\tau_L} D_L && \text{Saturated Porous Media} \\ D_e &= \frac{\theta_l}{\tau_L} D_L && \text{Unsaturated Porous Media} \\ D_e &= \frac{\theta_l}{\tau_L} D_L + \frac{\theta_g}{\tau_G} k_G D_G && \text{Unsaturated with Volatilization} \end{aligned}$$

Here  $D_F$ ,  $D_L$ , and  $D_G$  are the single-phase diffusion coefficients for the species diluted in a fluid, a pure liquid, and a gas phase, respectively (SI unit:  $\text{m}^2/\text{s}$ ), and  $\tau_F$ ,  $\tau_L$ , and  $\tau_G$  are the corresponding tortuosity factors (dimensionless).

The tortuosity factor accounts for the reduced diffusivity due to the fact that the solid grains impede Brownian motion. The interface provides predefined expressions to

compute the tortuosity factors in partially saturated porous media according to the Millington and Quirk model (Ref. 3):

$$\tau_L = \theta_l^{-7/3} \varepsilon_p^2, \tau_G = \theta_g^{-7/3} \varepsilon_p^2$$

and Bruggeman model

$$\tau_L = \theta_l^{-5/2} \varepsilon_p^2, \tau_G = \theta_g^{-5/2} \varepsilon_p^2$$

For saturated porous media  $\theta_l = \varepsilon_p$ . The fluid tortuosity for the Millington and Quirk model is

$$\tau_L = \varepsilon_p^{-1/3}$$

and for the Bruggeman model the tortuosity is defined as

$$\tau_L = \varepsilon_p^{-1/2}$$

User defined expressions for the tortuosity factor can also be applied.

### *Dispersion*

---

The contribution of dispersion to the mixing of species typically overshadows the contribution from molecular diffusion, except when the fluid velocity is very low.

The spreading of mass, as a fluid travel through a porous medium is caused by several contributing effects. Local variations in fluid velocity lead to mechanical mixing referred to as dispersion occurs because the fluid in the pore space flows around solid particles, so the velocity field varies within pore channels. The spreading in the direction parallel to the flow, or *longitudinal dispersivity*, typically exceeds the *transverse dispersivity* from up to an order of magnitude. Being driven by the concentration gradient alone, molecular diffusion rate is low relative to the mechanical dispersion, except at very low fluid velocities.

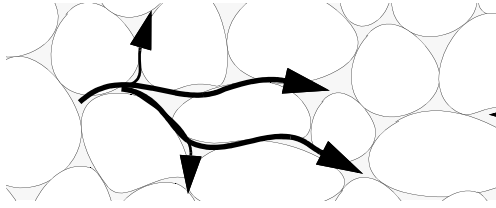

Figure 4-4: Spreading of fluid around solid particles in a porous medium.

The dispersion is controlled through the dispersion tensor  $D_D$ . The tensor components can either be given by user-defined values or expressions or derived from the directional dispersivities.

Using the longitudinal and transverse dispersivities in 2D, the dispersivity tensor components are (Ref. 5):

$$D_{Dii} = \alpha_L \frac{u_i^2}{|\mathbf{u}|} + \alpha_T \frac{u_j^2}{|\mathbf{u}|}$$

$$D_{Dij} = D_{Dji} = (\alpha_L - \alpha_T) \frac{u_i u_j}{|\mathbf{u}|}$$

In these equations,  $D_{Dii}$  (SI unit:  $\text{m}^2/\text{s}$ ) are the principal components of the dispersivity tensor, and  $D_{Dji}$  and  $D_{Dij}$  are the cross terms. The parameters  $\alpha_L$  and  $\alpha_T$  (SI unit: m) specify the longitudinal and transverse dispersivities; and  $u_i$  (SI unit: m/s) stands for the velocity field components.

In order to facilitate modeling of stratified porous media in 3D, the tensor formulation by Burnett and Frind (Ref. 4) can be used. Consider a transverse isotropic media, where the strata are piled up in the  $z$  direction, the dispersivity tensor components are:

$$\begin{aligned}
D_{Lxx} &= \alpha_1 \frac{u^2}{|\mathbf{u}|} + \alpha_2 \frac{v^2}{|\mathbf{u}|} + \alpha_3 \frac{w^2}{|\mathbf{u}|} \\
D_{Lyy} &= \alpha_1 \frac{v^2}{|\mathbf{u}|} + \alpha_2 \frac{u^2}{|\mathbf{u}|} + \alpha_3 \frac{w^2}{|\mathbf{u}|} \\
D_{Lzz} &= \alpha_1 \frac{w^2}{|\mathbf{u}|} + \alpha_2 \frac{u^2}{|\mathbf{u}|} + \alpha_3 \frac{v^2}{|\mathbf{u}|} \\
D_{Lxy} &= D_{Lyx} = (\alpha_1 - \alpha_2) \frac{uv}{|\mathbf{u}|} \\
D_{Lxz} &= D_{Lzx} = (\alpha_1 - \alpha_3) \frac{uw}{|\mathbf{u}|} \\
D_{Lyz} &= D_{Lzy} = (\alpha_1 - \alpha_3) \frac{vw}{|\mathbf{u}|}
\end{aligned} \tag{4-24}$$

In Equation 4-24 the fluid velocities  $u$ ,  $v$ , and  $w$  correspond to the components of the velocity field  $\mathbf{u}$  in the  $x$ ,  $y$ , and  $z$  directions, respectively, and  $\alpha_1$  (SI unit: m) is the longitudinal dispersivity. If  $z$  is the vertical axis,  $\alpha_2$  and  $\alpha_3$  are the dispersivities in the transverse horizontal and transverse vertical directions, respectively (SI unit: m). Setting  $\alpha_2 = \alpha_3$  gives the expressions for isotropic media shown in Bear (Ref. 5 and Ref. 6).

### *Adsorption*

---

As species travel through a porous medium they typically attach to (adsorb), and detach (desorb) from the solid phase, which slows chemical transport through the porous medium. Adsorption and desorption respectively reduces or increases species concentrations in the fluid. The adsorption properties vary between chemicals, so a plume containing multiple species can separate into components (Ref. 7). The Adsorption feature includes four predefined and one user-defined relationships to predict the solid concentrations,  $c_{pi}$  from the concentration in the liquid phase,  $c_i$ :

$$\begin{aligned}
c_P &= c_{P\max} \frac{K_L c}{1 + K_L c} && \text{Langmuir} \\
c_P &= K_F \left( \frac{c}{c_{\text{ref}}} \right)^{N_F} && \text{Freundlich} \\
c_P &= c_{P\max} \frac{b_T c}{(1 + (b_T c)^{N_T})^{1/N_T}} && \text{Toth} \\
c_P &= \frac{K_B c_0 c}{(c_S - c) \left( 1 + (K_B - 1) \frac{c}{c_S} \right)} && \text{BET}
\end{aligned} \tag{4-25}$$

The above equations contains the following parameters:

- Freundlich (Ref. 8)
  - Freundlich constant  $K_F$  (SI unit: mol/kg), Freundlich exponent  $N_F$  (dimensionless), and reference concentration  $c_{\text{ref}}$  (SI unit: mol/m<sup>3</sup>).
- Langmuir (Ref. 9)
  - Langmuir constant  $K_L$  (SI unit: m<sup>3</sup>/mol), and adsorption maximum  $c_{P\max}$  (SI unit: mol/kg).
- Toth (Ref. 10)
  - Toth constant  $b_T$  (SI unit: m<sup>3</sup>/mol), Toth exponent  $N_T$  (dimensionless), and adsorption maximum  $c_{P\max}$  (SI unit: mol/kg).
- BET (Brunauer–Emmett–Teller, Ref. 11)
  - BET constant  $K_B$  (dimensionless), the monolayer adsorption capacity  $c_0$  (SI unit: mol/kg) and the saturation concentration,  $c_S$  (SI unit: mol/m<sup>3</sup>).

These predefined expressions are adsorption isotherms that describe the amount of species sorbed to the solid. Applying the isotherms, as defined in the [Adsorption](#) section above, assumes that adsorption is at equilibrium locally. This implies that the species phase transfer, between the fluid and the solid phase (within the porous medium), is much faster than the transport within the fluid phase.

Using a [Species Source](#) feature, arbitrary expressions can be entered to define, for example, nonequilibrium and temperature-dependent adsorption laws, in the manner of Fetter (Ref. 12), or Bear and Verruijt (Ref. 13).

The retardation factor,  $\mathbf{RF}$ , describes how adsorption slows the solute velocity,  $\mathbf{u}_c$ , relative to the average linear velocity of the fluid,  $\mathbf{u}_a$ , as in

$$RF = 1 + \frac{\rho_b}{\theta} \frac{\partial c_P}{\partial c} = \frac{\mathbf{u}_a}{\mathbf{u}_c}$$

If the contaminant moves at the average linear velocity of the fluid for  $RF = 1$ . For  $RF > 1$ , the contaminant velocity is lower than the fluid velocity owing to residence time on solids.

### Reactions

---

Chemical reactions of all types influence species transport in porous media. Examples include biodegradation, radioactive decay, transformation to tracked products, temperature- and pressure-dependent functions, exothermic reactions, and endothermic reactions. The reactions represent change in species concentration per unit volume porous medium per time. Reaction terms are used on the right-hand side of the governing equation to represent these processes. For reactions in a fluid phase, multiply the expression by the fluid volume fraction  $\theta$ . Similarly, solid phase reaction expressions include the bulk density,  $\rho_b$ , and gas phase reactions include the gas volume fraction,  $\alpha_v$ .

The following expressions define some common types of reactions:

$$\begin{aligned}
 R_{Li} &= -\theta \frac{\ln 2}{\lambda_{Li}} c_i && \text{Radioactive decay — liquid} \\
 R_{Pi} &= -\rho_b \frac{\ln 2}{\lambda_{Pi}} \left( \frac{\partial c_{Pi}}{\partial c_i} \right) c_i && \text{Radioactive decay — solid} \\
 R_{Gi} &= -\frac{\ln 2}{\lambda_{Gi}} \alpha_v \left( \frac{\partial c_{Gi}}{\partial c} \right) c_i && \text{Radioactive decay — gas} \\
 R_{Lk} &= \theta \zeta_{Li} c_i && \text{Creation from parent } c_{Li} \text{ — liquid} \\
 R_{Pk} &= \rho_b \zeta_{Pi} \left( \frac{\partial c_{Pi}}{\partial c_i} \right) c_i && \text{Creation from sorbed parent } c_{Pi} \text{ — solid} \\
 R_{Gk} &= -\zeta \alpha_v \left( \frac{\partial c_{Gi}}{\partial c} \right) c_i && \text{Reaction — gas}
 \end{aligned}$$

where  $\lambda$  is the chemical half life,  $\zeta$  is a reaction rate, and the subscripts  $L$ ,  $P$ , and  $G$  denote liquid, solid, and gas phases, respectively. In the equations, the reactions either depend on liquid concentration  $c_i$  or solid phase concentrations  $c_{Pi}$  obtained using the sorption derivative with  $c_i$  or gas phase concentration  $c_{Gi}$  depending on the gas volume fraction, the volatilization, and the liquid concentration.

Reaction rates can vary with results from other equations in your model, such as temperature. For example, enter the Arrhenius rate law given in Ref. 14:

$$\zeta_T = \zeta_R \exp\left[\frac{E_a(T - T_R)}{R_u T T_R}\right] \quad (4-26)$$

In Equation 4-26,  $T$  denotes the current absolute temperature,  $T_R$  denotes the reference absolute temperature,  $E_a$  is the activation energy, and  $R_u$  is the universal gas constant.

### *Mass Transport in Fractures*

---

When thin fractures occur in porous media, fluid flow tends to move faster along the fracture than in the surrounding media. The transport of chemical species therefore also occur also faster in the direction of the fractures.

The fluid flow in a fracture can be modeled using Darcy's law formulated in a thin sheet of porous medium (a fracture):

$$\mathbf{u} = \frac{\kappa}{\mu} \nabla_t p$$

Here  $\mathbf{u}$  is the tangential Darcy velocity,  $\kappa$  is the fracture permeability,  $\mu$  the fluid's dynamic viscosity, and  $\nabla_t p$  is the tangential gradient of the fluid pressure.

The equation to solve for mass transport of species  $c_i$  in a thin fracture, embedded in a porous media, is derived from Equation 4-19. The resulting equation is:

$$d_{fr} \left( \frac{\partial \rho_b c_{p,i}}{\partial t} + \frac{\partial \varepsilon_p c_i}{\partial t} + \nabla_t \cdot (D_{e,i} \nabla_t c_i) + \mathbf{u} \cdot \nabla_t c_i \right) = d_{fr} R_i + d_{fr} S_i + n_0 \quad (4-27)$$

Here  $d_{fr}$  is the fracture thickness,  $c_{p,i}$  the amount of species adsorbed to (or desorbed from) the porous matrix (moles per unit dry weight of the solid),  $\varepsilon_p$  is the fracture porosity, and  $D_e$  is the effective diffusivity. The first two terms on the right hand side represent source terms from reactions, and  $n_0$  corresponds to out-of plane flux from the adjacent porous domain.

In order to arrive at the tangential differential equation, the gradient is split into the contributions normal and tangential to the fracture:

$$\nabla c_i = \nabla_n c_i + \nabla_t c_i$$

The normal gradient is defined in the direction normal to the boundary representing the fracture and the tangential gradient is defined along the boundary. Assuming that the variations in the normal (thin) direction of the fracture are negligible compared to those in the tangential direction, the gradient is simplified as:

$$\nabla c_i = \nabla_t c_i$$

Using The Transport of Diluted Species in Fractures Interface, the transport along fracture boundaries alone is solved for. In this case the transport in the surrounding porous media neglected and the out-of plane flux  $n_0$  vanishes.



See [Fracture](#) for more information about the boundary feature solving [Equation 4-27](#). See  for more information about the physics interface solving the equation on boundaries only.

## References

1. R. Codina, “A discontinuity-capturing crosswind-dissipation for the finite element solution of the convection-diffusion equation,” *Comput. Methods Appl. Mech. Eng.*, vol. 110, pp. 325–342, 1993.
2. P.V. Danckwerts, “Continuous flow systems: Distribution of residence times,” *Chem. Eng. Sci.*, vol. 2, no. 1, 1953.
3. R.J. Millington and J.M. Quirk, “Permeability of Porous Solids,” *Trans. Faraday Soc.*, vol. 57, pp. 1200–1207, 1961.
4. R.D. Burnett and E.O. Frind, “An Alternating Direction Galerkin Technique for Simulation of Groundwater Contaminant Transport in Three Dimensions: 2. Dimensionality Effects,” *Water Resour. Res.*, vol. 23, no. 4, pp. 695–705, 1987.
5. J. Bear, *Hydraulics of Groundwater*, McGraw Hill, 1979.
6. J. Bear, *Dynamics of Fluids in Porous Media*, Elsevier Scientific Publishing, 1972.
7. D.M. Mackay, D.L. Freyberg, P.V. Roberts, and J.A. Cherry, “A Natural Gradient Experiment on Solute Transport in a Sand Aquifer: 1. Approach and Overview of Plume Movement,” *Water Resour. Res.*, vol. 22, no. 13, pp. 2017–2030, 1986.
8. H.M.F. Freundlich, “Über die Adsorption in Lösungen” (in German), *Z. Phys. Chem.*, vol 57, pp. 385–470, 1906

9. I. Langmuir, "The Constitution and Fundamental Properties of Solids and Liquids, Part I Solids," *J. Am. Chem. Soc.*, vol. 38, pp. 2221–2295, 1916.
10. J. Toth, "State equation of the solid gas interface layer," *Acta Chem. Acad. Hung.* vol. 69, pp. 311–317, 1971.
11. S. Brunauer, P.H. Emmett, E. Teller, "Adsorption of gases in multimolecular layers," *J. Am. Chem. Soc.*, vol. 60, no. 2, pp. 309–319, 1938.
12. C.W. Fetter, *Contaminant Hydrogeology*, Prentice Hall, 1999.
13. J. Bear and A. Verruijt, *Modeling Groundwater Flow and Pollution*, D. Reidel Publishing, 1994.
14. I. Langmuir, "Chemical Reactions at Low Temperatures," *J. Amer. Chem. Soc.*, vol. 37, 1915.
15. J.M. Coulson and J.F. Richardson, *Chemical Engineering*, vol. 2, 4th ed., Pergamon Press, Oxford, U.K., 1991.
16. J.M. Coulson and J.F. Richardson, *Chemical Engineering*, vol. 1, 4th ed., Pergamon Press, Oxford, U.K., 1991.
17. D.E Rosner, *Transport Processes in Chemically Reacting Flow Systems*, ISBN-13: 978-1483130262, Butterworth–Heinemann, 1986.
18. R.B. Bird, W.E. Stewart, and E.N. Lightfoot, *Transport Phenomena*, 2nd ed., John Wiley & Sons, Inc., 2007.

# Theory for the Electrophoretic Transport Interface

The [Electrophoretic Transport Interface](#) models transport of charged and uncharged species, and in addition sets up a charge balance equation for the electrolyte potential.

The species concentrations are denoted,  $c_i$  (SI unit: mol/m<sup>3</sup>), and the potential,  $\phi_l$  (SI unit: V).

The species are transported by diffusion, migration, and (optionally) convection according to the Nernst–Planck set of equations. The total flux of species  $i$  is denoted  $\mathbf{N}_i$  (SI unit: mol/(m<sup>2</sup>·s)) according to

$$\mathbf{N}_i = -D_i \nabla c_i - z_i u_{m,i} F c_i \nabla \phi_l + \mathbf{u} c_i = \mathbf{J}_i + \mathbf{u} c_i \quad (4-28)$$

where  $D_i$  (SI unit: m<sup>2</sup>/s) is the diffusion coefficient,  $z_i$  (1) the corresponding charge,  $u_{m,i}$  (SI unit: s·mol/kg) the mobility and  $\mathbf{u}$  (SI unit: m/s) the velocity vector.  $\mathbf{J}_i$  denotes the molar flux relative to the convective transport (SI unit: mol/(m<sup>2</sup>·s)). For a detailed description of the theory of these equations and the different boundary conditions, see [Theory for the Transport of Diluted Species Interface](#).

## CHARGE BALANCE EQUATION

The current vector,  $\mathbf{i}_l$  (A/m<sup>2</sup>), is defined as

$$\mathbf{i}_l = \sum_i z_i \mathbf{N}_i \quad (4-29)$$

where the summation is made over all species in the electrolyte.

The governing equation for the electrolyte potential is

$$\nabla \cdot \mathbf{i}_l = Q_l \quad (4-30)$$

where  $Q_l$  (SI unit: A/m<sup>3</sup>) is the electrolyte current source stemming from, for example, porous electrode reactions. For nonporous electrode domains this source term is usually zero.

### PROTON AND HYDROXIDE CONCENTRATIONS AND ELECTRONEUTRALITY

Assuming the total number of species to be  $N + 2$ , the assumption of electroneutrality is

$$\sum_{i=1}^{N+2} z_i c_i = 0 \quad (4-31)$$

In water-based systems the species  $H^+$  and  $OH^-$  are always present. The auto ionization reaction for water is



This reaction is fast, following the equilibrium relation

$$c_{H^+} c_{OH^-} = K_w \times 1 \text{ mol}^2 \text{ dm}^{-6} \quad (4-33)$$

where  $K_w \approx 10^{-14}$ .

Now, the electroneutrality condition, including the two additional species  $H^+$  and  $OH^-$ , reads

$$c_{H^+} - c_{OH^-} + \sum_{i=1}^N z_i c_i = 0 \quad (4-34)$$

Combining these two equations results in the following algebraic expressions for the concentrations of  $H^+$  and  $OH^-$ .

$$c_{H^+} = -\frac{\Sigma}{2} + \sqrt{\frac{\Sigma^2}{4} + K_w \times 1 \text{ mol}^2 \text{ dm}^{-6}} \quad (4-35)$$

and

$$c_{OH^-} = \frac{\Sigma}{2} + \sqrt{\frac{\Sigma^2}{4} + K_w \times 1 \text{ mol}^2 \text{ dm}^{-6}} \quad (4-36)$$

where

$$\Sigma = \sum_{i=1}^N z_i c_i \quad (4-37)$$

### MASS BALANCE EQUATIONS FOR DISSOCIATION SPECIES

Assume a set of species  $S_i$  describing  $k$  dissociation steps from

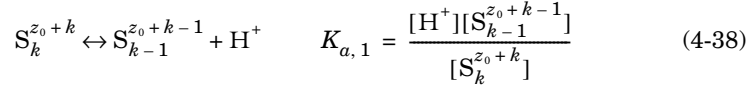

to

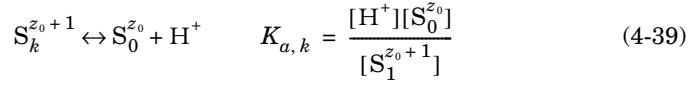

where  $z_0$  is the charge (valence) of species  $S_0$  (which has no dissociable protons) and  $K_{a,j}$  is the acid (equilibrium) constant of the  $j$ th dissociation reaction. The brackets “[ ]” here represent the species activity. The charge of each species is always deductible from the index  $i$  according to  $z_{0+i}$  and will be dropped from now on.

If the proton activity is known, any species  $S_m$  may be expressed using any other species  $S_l$  according to

$$[S_m] = \frac{[H]^{m-l}[S_l]}{k-l} \prod_{j=k-m+1} K_{a,j} \quad (4-40)$$

if  $m > l$  and

$$[S_m] = [H]^{m-l}[S_l] \prod_{j=k-l+1}^{k-m} K_{a,j} \quad (4-41)$$

if  $l > m$ .

Setting  $m = i$  and denoting the flux of species  $i$  by  $\mathbf{N}_i$  using equation [Equation 4-28](#), the mass balance equation for the concentration  $c_i$  of each subspecies  $i$  in the dissociation chain is

$$\frac{\delta c_i}{\delta t} + \nabla \cdot \mathbf{N}_i = R_{\text{eq},i,k-i} - R_{\text{eq},i,k-i+1} + R_i \quad (4-42)$$

where  $R_{\text{eq},i,j}$  is the reaction source stemming from the  $j$ th dissociation step (with  $R_{\text{eq},i,k+1} = 0$ ), and  $R_i$  any additional reaction sources.

The reaction source contributions from the dissociation steps are generally not known, but may be canceled by taking the sum of all mass balance equations, resulting in

$$\sum_{i=0}^k \left( \frac{\delta c_i}{\delta t} + \nabla \cdot \mathbf{N}_i \right) = \sum_{i=0}^k R_i \quad (4-43)$$

#### AVERAGE IONIZATION FORMULATION FOR LARGE MOLECULES

Large protein molecules are typically subject to a large number of dissociation steps.

As an alternative way to a long chain of dissociation steps for describing protein transport, you can instead formulate the protein transport based on the average number of protons  $\bar{v}$  (1) removed from the molecule.  $\bar{v}$  is typically provided as a function of pH, based on experimental data. The average charge of the species then is  $\bar{z} = z_0 - \bar{v}$ , so that the flux of the species is written as:

$$\mathbf{N}_i = -D\nabla c_i - \bar{z}u_m F c_i \nabla \phi_l + \mathbf{u}c_i \quad (4-44)$$

and similarly the addition to the charge neutrality condition is  $\bar{z}c_i$ .

When considering the contribution to the current and the charge balance equation you need to take into account that the squared average charge,  $\bar{z}^2 = (z_0 - \bar{v})^2$ , is not equal to the “average squared charge”,  $\bar{z}^2 = z_0^2 + 2z_0\bar{v} + \bar{v}^2 = \bar{z}^2 - \bar{v}^2 + \bar{v}^2$  (Ref. 1).

The addition to the current density vector is

$$\mathbf{i}_l = \dots - F(\bar{z}D_i \nabla c_i + \bar{z}^2 u_m c_i \nabla \phi_l) \quad (4-45)$$

The average number of protons removed from the proton typically depends on the pH. If the average number of removed protons depend only on the pH, the averaged squared number of protons removed can be written as

$$\bar{v}^2 = -c_{H^+} \frac{d}{dc_{H^+}} \bar{v} + \bar{v}^2 \quad (4-46)$$

And from this you can derive the average squared charge according to

$$\bar{z}^2 = -c_{H^+} \frac{d}{dc_{H^+}} \bar{v} + \bar{z}^2 = -c_{H^+} \frac{d}{dc_{H^+}} \bar{z} + \bar{z}^2 \quad (4-47)$$

#### DIFFUSIVITY-MOBILITY RELATIONS

The Stokes radius  $r$  of a molecule is related to the diffusivity according to

$$r = \frac{kT}{6\pi\mu D} \quad (4-48)$$

where  $\mu$  (SI unit: Pa·s) is the dynamic viscosity and  $k$  the Boltzmann constant.

For small molecules, there is the frequently used Nernst–Einstein relation between the diffusivity and the mobility

$$u_m = \frac{D}{RT} \quad (4-49)$$

For larger molecules, such as proteins, the mobility may instead be calculated based on the Debye–Hückel–Henry expression (Ref. 2) according to

$$u_m = \frac{ef(\kappa r)}{6\pi\mu F(1 + \kappa r)} = \frac{Df(\kappa r)}{RT(1 + \kappa r)} \quad (4-50)$$

where  $\kappa$  (1/m) is the Debye parameter, which depends on the ionic strength of the solution, is defined for ideal solutions as

$$\kappa^2 = \frac{2e^2 N_A}{\epsilon\epsilon_0 kT} \sum_{i=1}^N z_i^2 c_i \quad (4-51)$$

where  $\epsilon$  is the dielectric constant of the fluid and  $\epsilon_0$  the permittivity of free space. ( $z_i^2$  should be used if available in the formula above when calculating the ionic strength).

The function  $f$  above is based on a sigmoidal function so that it ranges from 1 for  $\kappa r = 0$  to 1.5 for  $\kappa r = \infty$ . Note that the Debye–Hückel–Henry expression approaches the Nernst–Einstein mobility as  $r \rightarrow 0$ .

For larger molecules (macro ions), where the distance between the charges is large compared to  $1/\kappa$ , the Linderström–Lang approximation postulates a smaller contribution of to the ionic strength so that the  $z$ -valent ion behaves as a monovalent ion with a  $z$ -fold concentration. For an assemble of  $N - M$  smaller molecules and  $M$  macro ions, the Debye parameter then is defined as

$$\kappa^2 = \frac{2e^2 N_A}{\epsilon\epsilon_0 kT} \left( \sum_{i=1}^{N-M} z_i^2 c_i + \sum_{i=N-M+1}^N \text{abs}(z_i) c_i \right) \quad (4-52)$$

## REFERENCES

1. R.A. Moshier, D.A. Saville, and W. Thormann, *The Dynamics of Electrophoresis*, VCH Verlagsgesellschaft mbH, Weinheim, Germany, 1992.
2. R.A. Moshier, P. Gebauer, J. Caslavská, and W. Thormann, “Computer Simulation and Experimental Validation of the Electrophoretic Behavior of Proteins. 2. Model Improvement and Application to Isotachopheresis,” *Anal. Chem.*, vol. 64, pp. 2991–2997, 1992.

# Theory for the Surface Reactions Interface

The [Surface Reactions Interface](#) solves for an arbitrary number of surface concentrations,  $c_{s,i}$  (SI unit: mol/m<sup>2</sup>), referring to species adsorbed on a reactive surface, and an arbitrary number of bulk concentrations  $c_{b,k}$  (SI unit: mol/m<sup>3</sup>), referring to the species in the solid material that constitutes the bulk of the reactive surface.

In this section:

- [Governing Equations for the Surface Concentrations](#)
- [Governing Equations for the Bulk Concentrations](#)
- [ODE Formulations for Surface Concentrations](#)
- [Surface Reaction Equations on Deforming Geometries](#)
- [Reference for the Surface Reactions Interface](#)

## *Governing Equations for the Surface Concentrations*

---

Transport of adsorbed species occurs in the tangential direction along the surface. The Surface Reactions interface models the tangential flux in the surface dimension, the *surface molar flux*,  $\mathbf{N}_{t,i}$  (SI unit: mol/(m·s)) (the subscript  $t$  refers to the tangential direction), as governed by diffusion according to Fick's law:

$$\mathbf{N}_{t,i} = -D_{s,i} \nabla_t c_{s,i}$$

where  $D_{s,i}$  (SI unit: m<sup>2</sup>/s) is the surface diffusion coefficient for species  $i$ .

The governing equation for the surface concentrations is written as

$$\frac{\partial c_{s,i}}{\partial t} = -\nabla_t \cdot \mathbf{N}_{t,i} + R_{s,i} \quad (4-53)$$

where  $R_{s,i}$  (SI unit: mol/(m<sup>2</sup>·s)) is the sum of all sources due to surface reactions and adsorption/desorption phenomena.

Of frequent interest for surface reaction kinetics are the fractional surface coverages,  $\theta_i$  (dimensionless), of the species (with index  $i$ ).

Writing the density of sites of the surface as  $\Gamma_s$  (SI unit: mol/m<sup>2</sup>) and the site occupancy number for each species as  $\sigma_i$  (dimensionless), the surface coverages can be calculated from

$$\theta_i = \frac{\sigma_i c_{s,i}}{\Gamma_s}$$

(The site occupancy number accounts for the situation when a large species covers more than one site on the surface.)

For the case of monolayer adsorption, the sum of all fractional coverages of free and adsorbed sites is unity, and hence the fraction of free sites on the surface,  $\theta_*$ , can be calculated from

$$\theta_* = 1 - \sum_i \theta_i$$

### *Governing Equations for the Bulk Concentrations*

---

#### **BULK SPECIES RATES AND GROWTH VELOCITY**

The reaction rate for a bulk species of index  $k$ , being added to the bulk due to surface reactions is defined as  $R_{b,k}$  (SI unit: mol/(s·m<sup>2</sup>)).

The reaction rate in mass basis,  $r_{b,k}$  (SI unit: kg/(s·m<sup>2</sup>)) for species  $k$ , is given by

$$r_k = M_k R_{b,k}$$

with  $M_k$  (SI unit: kg/mol) being the molar mass of the species.

Based on this, the species contribution to the bulk growth velocity,  $v_k$  (SI unit: m/s), is given by

$$v_{b,k} = \frac{r_{b,k}}{\rho_k}$$

where  $\rho_k$  is the species density (SI unit: kg/m<sup>3</sup>).

#### **TOTAL RATES AND VELOCITY**

To get the corresponding total values, a summation for all bulk species is made according to

$$R_{b, \text{tot}} = \sum_k R_{b, k}$$

$$r_{b, \text{tot}} = \sum_k r_{b, k}$$

$$v_{b, \text{tot}} = \sum_k v_{b, k}$$

### FRACTIONAL RATES AND VELOCITY

The fractional deposition rates are calculated by

$$R_{b, \text{frac}, k} = \frac{R_{b, k}}{R_{b, \text{tot}}}$$

$$r_{b, \text{frac}, k} = \frac{r_{b, k}}{r_{b, \text{tot}}}$$

$$v_{b, \text{frac}, k} = \frac{v_{b, k}}{v_{b, \text{tot}}}$$



The fractional deposition rates can be used as measures of the local fractional composition in a deposited layer at a certain thickness or time.

### ACCUMULATED BULK QUANTITIES

By solving for the bulk species concentrations for each time step, the accumulated mass and thickness changes of the bulk material can be calculated.

The bulk concentration,  $c_{b, k}$  (SI unit: mol/m<sup>2</sup>), for species  $k$  is governed by the equation

$$\frac{\partial c_{b, k}}{\partial t} = R_{b, k} \quad (4-54)$$

The bulk concentration in mass basis,  $m_{b, k}$  (SI unit: kg/m<sup>2</sup>) for a species  $k$ , can be derived from

$$m_{b, k} = M_k c_{b, k}$$

leading to the bulk thickness  $s_{b,k}$  (SI unit: m) of species  $k$  according to

$$s_{b,k} = \frac{m_{b,k}}{\rho_k}$$

#### **TOTAL BULK QUANTITIES**

The total bulk concentration is calculated according to

$$c_{b,\text{tot}} = \sum_k c_{b,k}$$

The deposited total mass,  $m_{b,\text{tot}}$  (SI unit: kg/m<sup>2</sup>) is

$$m_{b,\text{tot}} = \sum_k m_{b,k}$$

and the total bulk thickness,  $s_{\text{tot}}$  (SI unit: m) is

$$s_{b,\text{tot}} = \sum_k s_k$$

#### **FRACTIONAL QUANTITIES**

The fractional bulk concentration, bulk mass, and thickness (all dimensionless) are calculated according to

$$c_{b,\text{frac},k} = \frac{c_{b,k}}{c_{b,\text{tot}}}$$

$$m_{b,\text{frac},k} = \frac{m_{b,k}}{m_{b,\text{tot}}}$$

$$s_{b,\text{frac},k} = \frac{s_{b,k}}{s_{b,\text{tot}}}$$

### *ODE Formulations for Surface Concentrations*

---

The surface of a 1D geometry has a 0 dimension, hence no surface transport can be modeled and the governing equation is reduced to an ODE:

$$\frac{\partial c_{s,i}}{\partial t} = R_{s,i}$$

### *Surface Reaction Equations on Deforming Geometries*

---

If a Surface Reaction interface is used in conjunction with a Deformed Geometry or a Moving Mesh interface, the boundary concentration can either be assumed to be transported with the deforming geometry (moving mesh), with no compensation for the stretching (the Compensate for boundary stretching checkbox is not selected), or the species can be assumed to “float” on the mesh (the Compensate for boundary stretching checkbox is selected, which is the default). In the latter case the following is assumed in regard to the coupling between the surface species and bulk species and the mesh movement:

- Expansion or contraction of the boundary dilutes or increases concentration of the species, respectively, so that the surface integral (in spatial coordinates) of the species is kept constant.
- Tangential mesh movement has no impact on the local concentration in spatial coordinates, that is, the tangential transport of surface and bulk species does not move with the mesh in the tangential direction.

In order to comply with the additional contributions to the mass balance, equations are added. First, the following terms are added to the right-hand side of [Equation 4-53](#) and [Equation 4-54](#), respectively:

$$-c_{s,i} \frac{\partial}{\partial t} \ln \partial A$$

$$-c_{b,k} \frac{\partial}{\partial t} \ln \partial A$$

where  $\partial A$  is the infinitesimal mesh area segment (area scale factor). The above terms account for the concentration change due to a fractional area change.

Second, the resulting unwanted tangential convection, imposed by the mesh movement, is compensated for by the adding following terms to the right-hand side of [Equation 4-53](#) and [Equation 4-54](#), respectively:

$$\nabla_t \cdot (c_{s,i} \mathbf{v}_{t, \text{mesh}})$$

$$\nabla_t \cdot (c_{b,k} \mathbf{v}_{t, \text{mesh}})$$

where  $\mathbf{v}_{t,\text{mesh}}$  is the mesh velocity in the tangential direction.

This convective term needs often to be stabilized using methods such as streamline diffusion or isotropic diffusion.

### *Reference for the Surface Reactions Interface*

---

1. R.J. Kee, M.E. Coltrin, and P. Glarborg, *Chemically Reacting Flow*, Chapter 11, John Wiley & Sons, 2003.

# Theory for the Coupling of Mass Transport to Electrochemical Reactions

When relating the species fluxes at an electrode surface to the electric currents, the general chemical reaction formula

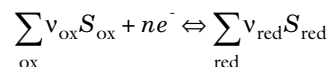

is used to define the stoichiometric coefficients,  $\nu_i$ , with  $\nu_i$  being positive ( $\nu_{\text{red}}$ ) for products and negative ( $\nu_{\text{ox}}$ ) for the reactants in a reduction reaction. The number of participating electrons,  $n$ , is always positive.

In this section:

- [Molar Sources and Sinks](#)
- [Mass Sources and Sinks](#)

## *Molar Sources and Sinks*

---

The molar species fluxes,  $N_i$  (SI unit: mol/(m<sup>2</sup>·s)), perpendicular to an electrode-electrolyte interface are calculated by summing all the flux contributions from the electrode reactions, of index  $m$ , according to Faraday's law:

$$N_i = \sum_m \frac{\nu_{i,m} i_m}{n_m F}$$

where  $i_m$  is the local current density (SI unit: A/m<sup>2</sup>) of the electrochemical reaction,  $n_m$  the number of participating electrons and  $F$  (SI unit: C/mol) is *Faraday's constant*.

The molar species flux,  $N_i$ , is obtained from normal component of the molar species flux vector over the electrode-electrolyte interface:

$$N_i = \mathbf{N}_i \cdot \mathbf{n}$$

where  $\mathbf{n}$  is the normal vector of the boundary pointing into the domain.

For a porous electrode, the electrochemical reactions result in species source terms calculated from:

$$R_{i, \text{molar}} = -\sum_m a_{v,m} \frac{v_{i,m} i_m}{n_m F}$$

where  $a_{v,m}$ , (SI unit:  $\text{m}^2/\text{m}^3$ ) is the specific surface area.

### *Mass Sources and Sinks*

---

To compute the mass flux of a species,  $\mathbf{n}_i$  (SI unit:  $\text{kg}/(\text{m}^2 \cdot \text{s})$ ), the molar flux is multiplied by the molar mass,  $M_i$  (SI unit:  $\text{kg}/\text{mol}$ ), resulting in

$$\mathbf{n}_i \cdot \mathbf{n} = M_i N_i$$

for a mass flux boundary, and

$$R_{i, \text{mass}} = M_i R_{i, \text{molar}}$$

for a porous source term.

In the Transport of Concentrated Species interface, where a nonconservative formulation of the flux equations are used, the source term is corrected for the mass change in the species transporting phase according to

$$R_{w_i, \text{nonconservative}} = M_i R_{i, \text{molar}} - w_i \sum_i M_i R_{i, \text{molar}} \quad (4-55)$$



Equation 4-55 is for a domain source only, the flux expression over a boundary is not changed for a nonconservative formulation.

---

# Fluid Flow Interfaces

This chapter describes the physics interfaces found under the **Fluid Flow** branch () . The chapter summarizes each physics interface including the different fields, material properties, and boundary conditions associated with them, and suggests how and when to apply it.

In this chapter:

- [The Laminar Flow and Creeping Flow Interfaces](#)
- [The Darcy's Law Interface](#)
- [The Free and Porous Media Flow, Brinkman Interface](#)
- [The Free and Porous Media Flow, Darcy Interface](#)
- [The Brinkman Equations Interface](#)
- [Theory for the Laminar Flow and Creeping Flow Interfaces](#)
- [Theory for the Darcy's Law Interface](#)
- [Theory for the Free and Porous Media Flow, Brinkman Interface](#)
- [Theory for the Free and Porous Media Flow, Darcy Interface](#)
- [Theory for the Brinkman Equations Interface](#)
- [Theory for the Coupling of Fluid Flow to Electrochemical Reactions](#)

# The Laminar Flow and Creeping Flow Interfaces

In this section:

- [The Creeping Flow Interface](#)
- [The Laminar Flow Interface](#)
- [Domain, Boundary, Pair, and Point Nodes for Single-Phase Flow](#)



- [Theory for the Laminar Flow and Creeping Flow Interfaces](#)
- 

In the *COMSOL Multiphysics Reference Manual*, see [Table 2-4](#) for links to common sections such as **Discretization**, **Consistent Stabilization**, **Inconsistent Stabilization**, and **Advanced Settings** sections, some of them accessed by clicking the **Show** button (  ) and choosing the applicable option. You can also search for information: press F1 to open the **Help** window or Ctrl+F1 to open the **Documentation** window.

## *The Creeping Flow Interface*

---

The **Creeping Flow (spf)** interface (  ) is used for simulating fluid flows at very low Reynolds numbers for which the inertial term in the Navier–Stokes equations can be neglected. Creeping flow, also referred to as Stokes flow, occurs in systems with high viscosity or small geometrical length scales (for example, in microfluidics and MEMS devices). The fluid can be compressible or incompressible, as well as Newtonian or non-Newtonian.

The equations solved by the Creeping Flow interface are the Stokes equations for conservation of momentum and the continuity equation for conservation of mass.

The Creeping Flow interface can be used for stationary and time-dependent analyses.

The main feature is the **Fluid Properties** node, which adds the Stokes equations and provides an interface for defining the fluid material and its properties. Except where noted below, see [The Laminar Flow Interface](#) for all other settings.

## PHYSICAL MODEL

By default, the **Neglect inertial term (Stokes flow)** checkbox is selected. If cleared, the inertial terms are included in the computations.

## DISCRETIZATION

By default, the Creeping Flow interface uses **P2+P1** elements. Contrary to general laminar and turbulent single-phase flow simulations employing purely linear P1+P1 elements, P2+P1 elements are well suited for most creeping flow simulations but are not in general fully conservative. Full conservation properties and high accuracy is obtained by selecting P2+P2 or P3+P3 elements.

Note that P1+P1, P2+P2, and P3+P3 discretizations (the so-called equal order interpolations) require streamline diffusion to be active.

## *The Laminar Flow Interface*

---

The **Laminar Flow (spf)** interface () is used to compute the velocity and pressure fields for the flow of a single-phase fluid in the laminar flow regime. A flow remains laminar as long as the Reynolds number is below a certain critical value. At higher Reynolds numbers, disturbances have a tendency to grow and cause transition to turbulence. This critical Reynolds number depends on the model, but a classical example is pipe flow, where the critical Reynolds number is known to be approximately 2000.

The physics interface supports incompressible flow, weakly compressible flow (the density depends on temperature but not on pressure), and compressible flow at low Mach numbers (typically less than 0.3). It also supports flow of non-Newtonian fluids.

The equations solved by the Laminar Flow interface are the Navier–Stokes equations for conservation of momentum and the continuity equation for conservation of mass.

The Laminar Flow interface can be used for stationary and time-dependent analyses. Time-dependent studies should be used in the high-Reynolds number regime as these flows tend to become inherently unsteady.

When the Laminar Flow interface is added, the following default nodes are also added in the **Model Builder: Fluid Properties, Wall** (the default boundary condition is **No slip**), and **Initial Values**. Other nodes that implement, for example, boundary conditions and volume forces, can be added from the **Physics** toolbar or from the context menu displayed when right-clicking **Laminar Flow**.

## SETTINGS

The **Label** is the default physics interface name.

The **Name** is used primarily as a scope prefix for variables defined by the physics interface. Physics interface variables can be referred to using the pattern `<name>.<variable_name>`. In order to distinguish between variables belonging to different physics interfaces, the `name` string must be unique. Only letters, numbers, and underscores (`_`) are permitted in the **Name** field. The first character must be a letter.

The default **Name** (for the first physics interface in the model) is `spf`.

### *About the Physics Interface Label Names*

The label for a single-phase flow interface (the node name in the Model Builder) is dynamic and is reset according to the turbulence model and the neglect inertial term (Stokes flow) property set at the physics interface level. The availability also depends on the software license.

If the **Neglect inertial term (Stokes flow)** checkbox is selected, then the Label changes to **Creeping Flow**, which is the same Label that displays when that interface is added from the Model Wizard or Add Physics window.

## PHYSICAL MODEL

### *Compressibility*

Depending of the fluid properties and the flow regime, three options are available for the **Compressibility** option. In general the computational complexity increases from **Incompressible flow** to **Weakly compressible flow** to **Compressible flow (Ma<0.3)** but the underlying hypotheses are increasingly more restrictive in the opposite direction.

When the **Incompressible flow** option (default) is selected, the incompressible form of the Navier–Stokes and continuity equations is applied. In addition, the fluid density is evaluated at the **Reference pressure level** defined in this section. The **Reference temperature** is set to 293.15 K.

The **Weakly compressible flow** option models compressible flow when the pressure dependency of the density can be neglected. When selected, the compressible form of the Navier–Stokes and continuity equations is applied. In addition, the fluid density is evaluated at the **Reference pressure level** defined in this section.

When the **Compressible flow (Ma<0.3)** option is selected, the compressible form of the Navier–Stokes and continuity equations is applied.  $Ma < 0.3$  indicates that the inlet and outlet conditions, as well as the stabilization, may not be suitable for transonic and supersonic flow. For more information, see [The Mach Number Limit](#).

### *Neglect Inertial Term (Stokes Flow)*

For low Reynolds number flows, the inertial terms in the Navier–Stokes equations may be neglected.

### *Porous Media Domains*

With the addition of various modules, the **Enable porous media domains** checkbox is available. Selecting this option, a **Fluid and Matrix Properties** node, a **Mass Source** node, and a **Forchheimer Drag** subnode are added to the physics interface. These are described for the **Brinkman Equations** interface in the respective module’s documentation. The **Fluid and Matrix Properties** can be applied on all domains or on a subset of the domains.

### *Porous Treatment of No Slip Condition*

**Porous treatment of no slip condition** is available when **Enable porous media domains** is activated. It controls how the **No Slip** condition on **Wall** boundaries and **Interior Wall** boundaries adjacent to **Porous Medium** should be treated. The options are **Standard no slip formulation** (default) and **Porous slip**. The latter option provides a unified treatment when the porous matrix is fully resolved as well as when it is under resolved ensuring a smooth transition between regions with different resolutions; see No Slip under [Wall](#).

### *Include Gravity*

When the **Include gravity** checkbox is selected, a global **Gravity** feature is shown in the interface model tree, and the buoyancy force is included in the Navier–Stokes equations.

Also, when the **Include gravity** checkbox is selected, the **Use reduced pressure** option changes the pressure formulation from using the total pressure (default) to using the reduced pressure. This option is suitable for configurations where the density changes are very small; otherwise, the default formulation can be used. For more information, see [Gravity](#)

### *Reference Values*

Reference values are global quantities used to evaluate the density of the fluid when the **Incompressible flow** or the **Weakly compressible flow** option is selected.

**Reference pressure level** There are generally two ways to include the pressure in fluid flow computations: either to use the absolute pressure  $p_A = p + p_{\text{ref}}$ , or the gauge pressure  $p$ . When  $p_{\text{ref}}$  is nonzero, the physics interface solves for the gauge pressure whereas material properties are evaluated using the absolute pressure. The reference pressure level is also used to define the reference density.

**Reference temperature** The reference temperature is used to define the reference density.

**Reference position** When **Include gravity** or **Rotating frame** is selected, the reference position can be defined. It corresponds to the location where the total pressure (that includes the hydrostatic pressure) is equal to the **Reference pressure level**.

#### DEPENDENT VARIABLES

The following dependent variables (fields) are defined for this physics interface — the **Velocity field  $\mathbf{u}$**  and its components, and the **Pressure  $p$** .

If required, the names of the field, component, and dependent variable can be edited. Editing the name of a scalar dependent variable changes both its field name and the dependent variable name. If a new field name coincides with the name of another field of the same type, the fields share degrees of freedom and dependent variable names. A new field name must not coincide with the name of a field of another type or with a component name belonging to some other field. Component names must be unique within a model except when two fields share a common field name.

#### CONSISTENT STABILIZATION

To enable this section, click the **Show More Options** button (  ) and select **Stabilization** in the **Show More Options** dialog.

There are two *consistent stabilization methods*: **Streamline diffusion** and **Crosswind diffusion**. Usually, both checkboxes for these methods are selected by default and should remain selected for optimal performance. Consistent stabilization methods do not perturb the original transport equation. Streamline diffusion must be selected when using equal-order interpolation for pressure and velocity.

Select the **Use dynamic subgrid time scale** checkbox to estimate the influence of temporal variations in the velocity field, instead of using the inverse time step, in the consistent stabilization terms. This checkbox is selected by default

Select the **Limit small time steps effect on stabilization time scale** checkbox to prevent loss of stabilization at small time steps.

#### INCONSISTENT STABILIZATION

To enable this section, click the **Show More Options** button (  ) and select **Stabilization** in the **Show More Options** dialog.

There is usually just one *inconsistent stabilization method* — **Isotropic diffusion**. This method is equivalent to adding a term to the diffusion coefficient in order to dampen

the effect of oscillations by making the system somewhat less dominated by convection. If possible, minimize the use of the inconsistent stabilization method because by using it you no longer solve the original problem. By default, the **Isotropic diffusion** checkbox is not selected because this type of stabilization adds artificial diffusion and affects the accuracy of the original problem. However, this option can be used to get a good initial guess for underresolved problems.

If required, select the **Isotropic diffusion** checkbox and enter a **Tuning parameter**  $\delta_{id}$  as a scalar positive value. The default value is 0.25 (a reasonable value to start with is roughly 0.5 divided by the element order). A higher value adds more isotropic diffusion.



- [Numerical Stability — Stabilization Techniques for Fluid Flow](#)
- 

#### ADVANCED SETTINGS

To display this section, click the **Show More Options** button (  ) and select **Advanced Physics Options** in the **Show More Options** dialog. Normally these settings do not need to be changed.

The **Use pseudo time stepping for stationary equation form** is per default set to **Automatic from physics**. This option can add pseudo time derivatives to the equation when the **Stationary equation** form is used in order to speed up convergence. Pseudo time stepping is triggered when the Laminar Flow interface is selected in some multiphysics coupling features. Set **Automatic from physics** to **On** to apply pseudo time stepping also for laminar flows. Set it to **Off** to disable pseudo time stepping completely.

When **Use pseudo time stepping for stationary equation form** is set to **Automatic from physics** or **On**, a **CFL number expression** should also be defined. For the default **Automatic** option, the local CFL number (from the Courant–Friedrichs–Lewy condition) is determined by a PID regulator.

The **Use Block Navier–Stokes preconditioner** checkbox under **Linear solver** is available when the **Compressibility** option is set to **Incompressible flow**. When this checkbox is selected, the default solver for time-dependent study steps will use the Block Navier–Stokes preconditioner in iterative solvers for the velocity and pressure. Using this

preconditioner may result in shorter solution times for large time-dependent problems with high Reynolds numbers.



- [Pseudo Time Stepping for Laminar Flow Models](#)
- [Domain, Boundary, Pair, and Point Nodes for Single-Phase Flow](#)
- [Theory for the Laminar Flow and Creeping Flow Interfaces](#)
- [Block Navier–Stokes](#) in the *COMSOL Multiphysics Reference Manual*.

### DISCRETIZATION

The default discretization for Laminar Flow is **P1+P1** elements — that is, piecewise linear interpolation for velocity and pressure. This is suitable for most flow problems.

Some higher-order interpolations are also available, and they can be cost-effective options to obtain high accuracy for flows with low Reynolds numbers.

The **P2+P2** and **P3+P3** options, the equal-order interpolation options, are the preferred higher-order options because they have higher numerical accuracy than the mixed-order options **P2+P1** and **P3+P2**. The equal-order interpolation options do, however, require streamline diffusion to be active.



*Flow Past a Cylinder*: Application Library path **COMSOL\_Multiphysics/Fluid\_Dynamics/cylinder\_flow**

## Domain, Boundary, Pair, and Point Nodes for Single-Phase Flow

---

The following nodes, listed in alphabetical order, are available from the **Physics** ribbon toolbar (Windows users), **Physics** context menu (Mac or Linux users), or by right-clicking to access the context menu (all users).

- Average Pressure
- Boundary Stress
- Flow Continuity
- Fluid Properties
- Gravity
- Initial Values
- Inlet
- Line Mass Source<sup>1</sup>
- Open Boundary
- Outlet
- Periodic Flow Condition
- Point Mass Source<sup>1</sup>
- Porous Interface
- Pressure Point Constraint
- Rotating Frame
- Symmetry
- Volume Force
- Wall

<sup>1</sup> A feature that may require an additional license



For 2D axisymmetric components, COMSOL Multiphysics takes the axial symmetry boundaries (at  $r = 0$ ) into account and adds an **Axial Symmetry** node that is valid on the axial symmetry boundaries only.

---

In the *COMSOL Multiphysics Reference Manual*, see [Table 2-4](#) for links to common sections and [Table 2-5](#) to common feature nodes. You can also search for information: press F1 to open the **Help** window or Ctrl+F1 to open the **Documentation** window.



For a detailed overview of the functionality available in each product, visit [www.comsol.com/products/specifications/](http://www.comsol.com/products/specifications/)

---

## Fluid Properties

---

The **Fluid Properties** node adds the momentum and continuity equations solved by the physics interface, except for volume forces, which are added by the [Volume Force](#)

feature. The node also provides an interface for defining the material properties of the fluid.

### MODEL INPUTS

Fluid properties, such as density and viscosity, can be defined through user inputs, variables, or by selecting a material. For the latter option, additional inputs, for example temperature or pressure, may be required to define these properties.

#### *Temperature*

By default, the **Temperature** model input is set to **Common model input**, and the temperature is controlled from **Default Model Inputs** under **Global Definitions** or by a locally defined **Model Input**. If a Heat Transfer interface is included in the component, it controls the temperature **Common model input**. Alternatively, the temperature field can be selected from another physics interface. All physics interfaces have their own tags (**Name**). For example, if a Heat Transfer in Fluids interface is included in the component, the **Temperature (ht)** option is available for  $T$ .

You can also select **User defined** from the **Temperature** model input in order to manually prescribe  $T$ .

#### *Absolute Pressure*

This input appears when a material requires the absolute pressure as a model input. The absolute pressure is used to evaluate material properties, but it also relates to the value of the calculated pressure field. There are generally two ways to calculate the pressure when describing fluid flow: either to solve for the absolute pressure or for a pressure (often denoted gauge pressure) that relates to the absolute pressure through a reference pressure.

The choice of pressure variable depends on the system of equations being solved. For example, in a unidirectional incompressible flow problem, the pressure drop over the modeled domain is probably many orders of magnitude smaller than the atmospheric pressure, which, when included, may reduce the stability and convergence properties of the solver. In other cases, such as when the pressure is part of an expression for the gas volume or the diffusion coefficients, it may be more convenient to solve for the absolute pressure.

The default **Absolute pressure**  $p_A$  is  $p + p_{\text{ref}}$ , where  $p$  is the dependent pressure variable from the Navier–Stokes or RANS equations, and  $p_{\text{ref}}$  is from the user input defined at the physics interface level. When  $p_{\text{ref}}$  is nonzero, the physics interface solves for a gauge pressure. If the pressure field instead is an absolute pressure field,  $p_{\text{ref}}$  should be set to 0.

The **Absolute pressure** field can be edited by clicking **Make All Model Inputs Editable** (  ) and entering the desired value in the input field.



## FLUID PROPERTIES

### *Density*

The density can either be specified by a material, or by a **User defined** expression. The density in a material can depend on temperature and pressure, and these dependencies are automatically replaced by  $p_{\text{ref}}$  for weakly compressible flows and  $p_{\text{ref}}$  and  $T_{\text{ref}}$  for incompressible flows (as specified by the **Compressibility** setting at the physics interface level). If density variations with respect to pressure are to be included in the computations, **Compressibility** must be set to compressible. Any dependencies in the density on quantities other than temperature and pressure must be consistent with the **Compressibility** setting at the interface level.

### *Dynamic Viscosity*

The **Dynamic viscosity**  $\mu$  describes the relationship between the shear rate and the shear stresses in a fluid. Intuitively, water and air have low viscosities, and substances often described as thick (such as oil) have higher viscosities.

### *Volume Force*

The **Volume Force** node specifies the volume force  $\mathbf{F}$  on the right-hand side of the momentum equation.

$$\rho \frac{\partial \mathbf{u}}{\partial t} + \rho (\mathbf{u} \cdot \nabla) \mathbf{u} = \nabla \cdot \left[ -p \mathbf{I} + \mu (\nabla \mathbf{u} + (\nabla \mathbf{u})^T) - \frac{2}{3} \mu (\nabla \cdot \mathbf{u}) \mathbf{I} \right] + \mathbf{F}$$

If several volume-force nodes are added to the same domain, then the sum of all contributions are added to the momentum equation.

### *Initial Values*

The initial values serve as initial conditions for a transient simulation or as an initial guess for a nonlinear solver in a stationary simulation. Note that for a transient compressible-flow simulation employing a material for which the density depends on

the pressure (such as air), discontinuities in the initial values trigger pressure waves even when the Mach number is small. The pressure waves must be resolved and this puts a restriction on the time step.

### INITIAL VALUES

Initial values or expressions should be specified for the **Velocity field  $\mathbf{u}$**  and the **Pressure  $p$** .

When **Include gravity** is selected and **Use reduced pressure** not selected in the interface **Physical model** section, the **Compensate for hydrostatic pressure approximation** (named **Compensate for hydrostatic pressure** for compressible flows) checkbox is available and selected by default. When it is selected, the hydrostatic pressure is automatically added to the pressure entered in  $p$  user input.

### *Wall*

---

The **Wall** node includes a set of boundary conditions describing fluid-flow conditions at stationary, moving, and leaking walls. For turbulent flow, the description may involve wall functions and asymptotic expressions for certain turbulence variables.

### BOUNDARY CONDITION

Select a **Boundary condition** for the wall.

- [No Slip](#)
- [Slip](#)
- [Leaking Wall](#)

### *No Slip*

**No slip** is the default boundary condition to model solid walls. A no-slip wall is a wall where the fluid velocity relative to the wall velocity is zero. For a stationary wall that means that  $\mathbf{u} = 0$ .

The option for **Porous treatment of no slip condition** is available when **Enable porous media domains** is activated in the **Physical Model** section in the settings for the main physics interface node. It specifies how **Wall** boundaries and **Interior Wall** boundaries adjacent to porous domains are treated. When **Standard no slip formulation** is chosen, a common no slip condition is applied on all solid walls. When the default **Porous slip** is chosen, a blending analytic expression is instead applied on the corresponding wall boundaries adjacent to the porous medium domain. It results in a no slip condition in case the porous length scale is fully resolved by the mesh and a slip condition in the

opposite limit when the mesh is much coarser than the porous scale. A smooth transition between these limits is ensured. Note that the interpretation and usage of nonzero slip at the wall is the same as in the **Navier slip** boundary condition. By default, **Velocity formulation** is on and the treatment is based on an approximate reconstruction of the far-field pressure gradient using the slip velocity at the wall. If the **Pressure-gradient formulation** is chosen, the local pressure gradient at the wall is employed.

### *Slip*

The **Slip** option prescribes a no-penetration condition,  $\mathbf{u} \cdot \mathbf{n} = 0$ . It is implicitly assumed that there are no viscous effects at the slip wall and hence, no boundary layer develops. From a modeling point of view, this can be a reasonable approximation if the main effect of the wall is to prevent fluid from leaving the domain.

### *Leaking Wall*

This boundary condition may be used to simulate a wall where fluid is leaking into or leaving the domain with the velocity  $\mathbf{u} = \mathbf{u}_l$  through a perforated wall. The components of the **Fluid velocity**  $\mathbf{u}_l$  on the leaking wall should be specified.

## **WALL MOVEMENT**

This section contains controls to describe the wall movement relative to the lab (or spatial) frame.

The **Translational velocity** setting controls the translational wall velocity,  $\mathbf{u}_{tr}$ . The list is per default set to **Automatic from frame**. The physics automatically detects if the spatial frame moves. This can for example happen if an ALE interface is present in the model component. If there is no movement  $\mathbf{u}_{tr} = \mathbf{0}$ . If the frame moves,  $\mathbf{u}_{tr}$  becomes equal to the frame movement.  $\mathbf{u}_{tr}$  is accounted for in the actual boundary condition prescribed in the **Boundary condition** section.

Select **Zero (Fixed wall)** from **Translational velocity** selection list to prescribe  $\mathbf{u}_{tr} = \mathbf{0}$ .

Select **Manual** from **Translational velocity** selection list in order to manually prescribe **Velocity of moving wall**,  $\mathbf{u}_{tr}$ . This can for example be used to model an oscillating wall where the magnitude of the oscillations are very small compared to the rest of the model. Specifying translational velocity manually does not automatically cause the associated wall to move. An additional Moving Mesh node needs to be added from Definitions to physically track the wall movement in the spatial reference frame.

The **Sliding wall** option is appropriate if the wall behaves like a conveyor belt with the surface sliding in a tangential direction. A velocity is prescribed at the wall and the boundary itself does not have to actually move relative to the reference frame.

- For 3D components, values or expressions for the **Velocity of sliding wall**  $\mathbf{u}_w$  should be specified. If the velocity vector entered is not in the plane of the wall, COMSOL Multiphysics projects it onto the tangential direction. Its magnitude is adjusted to be the same as the magnitude of the vector entered.
- For 2D components, the tangential direction is unambiguously defined by the direction of the boundary. For this reason, the sliding wall boundary condition has different definitions in different space dimensions. A single entry for the **Velocity of the tangentially moving wall**  $U_w$  should be specified in 2D.

### CONSTRAINT SETTINGS

This section is displayed by clicking the **Show More Options** button (  ) and selecting **Advanced Physics Options** in the **Show More Options** dialog. The **Constraints** settings can be set to **Automatic**, **Pointwise constraints**, **Nitsche constraints**, or **Weak constraints**. **Mixed constraints** can be selected when imposing a no slip condition exactly.

Depending on the constraint method selected, the following settings are available:

- **Apply reaction terms on** can be set to **Individual dependent variables** (default) or **All physics (symmetric)**. This setting is not available when **Nitsche constraints** is selected.
- Select **Elemental** (default) or **Nodal** under **Constraint method**. This setting is not available for **Nitsche constraints** or **Weak constraints**.



- [Theory for the Wall Boundary Condition](#)
  - [The Moving Mesh Interface](#) in the *COMSOL Multiphysics Reference Manual*
- 

### *Inlet*

This condition should be used on boundaries for which there is a net flow into the domain. To obtain a numerically well-posed problem, it is advisable to also consider the Outlet conditions when specifying an Inlet condition. For example, if the pressure is specified at the outlet, the velocity may be specified at the inlet, and vice versa. Specifying the velocity vector at both the inlet and the outlet may cause convergence difficulties.

## BOUNDARY CONDITION

The available **Boundary condition** options for an inlet are **Velocity**, **Fully developed flow**, and **Pressure**. After selecting a **Boundary Condition** from the list, a section with the same or a similar name displays underneath. For example, if **Velocity** is selected, a **Velocity** section, where further settings are defined, is displayed.

## VELOCITY

The **Normal inflow velocity** is specified as  $\mathbf{u} = -\mathbf{n}U_0$ , where  $\mathbf{n}$  is the boundary normal pointing out of the domain and  $U_0$  is the normal inflow speed.

The **Velocity field** option sets the velocity vector to  $\mathbf{u} = \mathbf{u}_0$ . The components of the inlet velocity vector  $\mathbf{u}_0$  should be defined for this choice.

## PRESSURE CONDITIONS

This option specifies the normal stress, which in most cases is approximately equal to the pressure.

- For incompressible flow, the **Pressure** list has two options, **Static** and **Total**. For weakly compressible and compressible flow, the static pressure should be specified in the text field.
  - If **Pressure** is **Static**, and the reference pressure  $p_{\text{ref}}$ , defined at the physics interface level, is equal to 0, the value of the pressure  $p_0$ , at the boundary, is the absolute pressure. Otherwise,  $p_0$  is the relative pressure at the boundary.
  - If **Pressure** is **Total**, the **Average** checkbox is available and cleared by default to prescribe the total pressure pointwise. If it is selected, the averaged total pressure is imposed in the weak forms instead.

When **Include gravity** is selected and **Use reduced pressure** not selected in the interface **Physical model** section, the **Compensate for hydrostatic pressure approximation** (named **Compensate for hydrostatic pressure** for incompressible flows) checkbox is available and selected by default. When it is selected, the hydrostatic pressure is automatically added to the pressure entered in  $p_0$  user input.

- The **Suppress backflow** option adjusts the inlet pressure locally in order to reduce the amount of fluid exiting the domain through the boundary. If you clear the suppress backflow option, the inlet boundary can become an outlet depending on the pressure field in the rest of the domain.

- **Flow direction** controls in which direction the fluid enters the domain.
  - For **Normal flow**, it prescribes zero tangential velocity component.
  - For **User defined**, an **Inflow velocity direction**  $\mathbf{d}_u$  (dimensionless) should be specified. The magnitude of  $\mathbf{d}_u$  does not matter, only the direction.  $\mathbf{d}_u$  must point into the domain.

## MASS FLOW

The mass flow at an inlet can be specified by the **Mass flow rate**, the **Pointwise mass flux**, the **Standard flow rate**, or the **Standard flow rate (SCCM)**.

The **Apply condition on each disjoint selection separately** checkbox is selected per default. When this setting is selected, the mass flow condition is applied separately on each disjoint selection. If this option is not selected, the condition is applied over the whole feature selection. The **Apply condition on each disjoint selection separately** should be disabled only if the flow conditions are known to be identical on each disjoint boundary.

### *Mass Flow Rate*

The **Mass flow rate** option sets the integrated mass flow over the boundary selection, the **Normal mass flow rate** to a specific value,  $m$ . The mass flow is assumed to be parallel to the boundary normal, and the tangential flow velocity is set to zero.

For 2D components, the **Channel thickness**  $d_{bc}$  is used to define the area across which the mass flow occurs. This setting is not applied to the whole model. Line or surface integrals of the mass flow over the boundary evaluated during postprocessing or used in integration coupling operators do not include this scaling automatically. Such results should be appropriately scaled when comparing them with the specified mass flow.

### *Pointwise Mass Flux*

The **Pointwise mass flux** sets the mass flow parallel to the boundary normal. The tangential flow velocity is set to zero. The mass flux is a model input, which means that COMSOL Multiphysics can take its value from another physics interface when available. When **User defined** is selected a value or function  $M_f$  should be specified for the **Mass flux**.

### *Standard Flow Rate*

The **Standard flow rate**  $Q_{sv}$  sets a standard volumetric flow rate, according to the SEMI standard E12-0303. The mass flow rate is specified as the volumetric flow rate of a gas at standard density — the **Mean molar mass**  $M_n$  divided by a **Standard molar volume**  $V_m$  (that is, the volume of one mole of a perfect gas at standard pressure and standard

temperature). The flow occurs across the whole boundary in the direction of the boundary normal and is computed by a surface (3D) or line (2D) integral. The tangential flow velocity is set to zero.

The standard density can be defined directly, or by specifying a standard pressure and temperature, in which case the ideal gas law is assumed. The options in the **Standard flow rate defined by** list are:

- **Standard density**, for which the **Standard molar volume**  $V_m$  should be specified.
- **Standard pressure and temperature**, for which the **Standard pressure**  $P_{st}$  and the **Standard temperature**  $T_{st}$  should be defined.

For 2D components, the **Channel thickness**  $d_{bc}$  is used to define the area across which the mass flow occurs. This setting is not applied to the whole model. Line or surface integrals of the mass flow over the boundary evaluated during postprocessing or used in integration coupling operators do not include this scaling automatically. Such results should be appropriately scaled when comparing them with the specified mass flow.

#### *Standard Flow Rate (SCCM)*

The **Standard flow rate (SCCM)** boundary condition is equivalent to the **Standard flow rate** boundary condition, except that the flow rate is entered directly in SCCMs (standard cubic centimeters per minute) without the requirement to specify units. Here, the dimensionless **Number of SCCM units**  $Q_{sccm}$  should be specified.

### **FULLY DEVELOPED FLOW**

The **Fully developed flow** option adds contributions to the inflow boundary, which force the flow toward the solution for a fully developed channel flow. The channel can be thought of as a virtual extrusion of the inlet cross section. The inlet boundary must hence be flat in order for the fully developed flow condition to work properly. In 2D axisymmetric models, the inlet normal must be parallel to the symmetry axis.

Select an option to control the flow rate at the inlet:

- **Average velocity**,  $U_{av}$ .
- **Flow rate**,  $V_0$ . Two-dimensional models also require an **Entrance thickness**,  $D_z$ , which is the out-of-plane thickness of the extruded entrance channel.
- **Average pressure**,  $P_{av}$ . Note that  $P_{av}$  is the average pressure on the inflow boundary.

The **Apply condition on each disjoint selection separately** checkbox is selected per default. When this setting is selected, the fully developed flow condition is applied separately on each disjoint selection. If this option is not selected, the condition is

applied over the whole feature selection. The **Apply condition on each disjoint selection separately** should be disabled only if the flow conditions are known to be identical on each disjoint boundary.

The fully developed flow condition requires any volume force to be approximately aligned with the normal of the inlet boundary. The exception is gravity when the **Include gravity** setting is selected in the physics interface settings. Unless **Use reduced pressure** is also selected, an option to **Compensate for hydrostatic pressure** or **Compensate for hydrostatic pressure approximation** becomes available. It is selected per default and should only be deselected if the inlet normal is aligned with the gravity force and you want to specify an average pressure that includes the hydrostatic pressure.

### CONSTRAINT SETTINGS

This section is displayed by clicking the **Show** button (  ) and selecting **Advanced Physics Options**.

---

	<ul style="list-style-type: none"><li>• <a href="#">Prescribing Inlet and Outlet Conditions</a></li><li>• <a href="#">Normal Stress Boundary Condition</a></li></ul>
---	--

---

	<a href="#">Fully Developed Flow (Inlet)</a>
---	--

---

### *Outlet*

This condition should be used on boundaries for which there is a net outflow from the domain. To obtain a numerically well-posed problem, it is advisable to also consider the Inlet conditions when specifying an Outlet condition. For example, if the velocity is specified at the inlet, the pressure may be specified at the outlet, and vice versa. Specifying the velocity vector at both the inlet and the outlet may cause convergence difficulties. Selecting appropriate outlet conditions for the Navier–Stokes equations is a nontrivial task. Generally, if there is something interesting happening at an outflow boundary, the computational domain should be extended to include this phenomenon.

## BOUNDARY CONDITION

The available **Boundary condition** options for an outlet are **Pressure**, **Velocity**, **Fully developed flow**, and **Mass flow**.

## PRESSURE CONDITIONS

This option specifies the normal stress, which in most cases is approximately equal to the pressure. The tangential stress component is set to zero.

- For incompressible flow, the **Pressure** list has two options, **Static** and **Total**. For weakly compressible and compressible flow, the static pressure should be specified in the text field.
  - If **Pressure** is **Static**, and the reference pressure  $p_{\text{ref}}$ , defined at the physics interface level, is equal to 0, the value of the pressure  $p_0$ , at the boundary, is the absolute pressure. Otherwise,  $p_0$  is the relative pressure at the boundary.
  - If **Pressure** is **Total**, the **Average** checkbox is available and selected by default to prescribed the averaged total pressure in the weak forms. If it is cleared, the total pressure is imposed pointwise.

When **Include gravity** is selected and **Use reduced pressure** not selected in the interface **Physical model** section, the **Compensate for hydrostatic pressure approximation** (named **Compensate for hydrostatic pressure** for incompressible flows) checkbox is available and selected by default. When it is selected, the hydrostatic pressure is automatically added to the pressure entered in  $p_0$  user input.

- The **Normal flow** option changes the no tangential stress condition to a no tangential velocity condition. This forces the flow to exit (or enter) the domain perpendicularly to the outlet boundary.
- The **Suppress backflow** checkbox is selected by default. This option adjusts the outlet pressure in order to reduce the amount of fluid entering the domain through the boundary.

## VELOCITY

See the **Inlet** node **Velocity** section for the settings.

## FULLY DEVELOPED FLOW

This boundary condition is applicable when the flow exits the domain into a long pipe or channel, at the end of which a flow profile is fully developed.

The channel can be thought of as a virtual extrusion of the outlet cross section. The outlet boundary must hence be flat in order for the fully developed flow condition to

work properly. In 2D axisymmetric models, the outlet normal must be parallel to the symmetry axis.

Select an option to control the flow rate at the outlet:

- **Average velocity**,  $U_{av}$ .
- **Flow rate**,  $V_0$ . Two-dimensional models also require an **Entrance thickness**,  $D_z$ , which is the out-of-plane thickness of the extruded entrance channel.
- **Average pressure**,  $P_{av}$ . Observe that  $P_{av}$  is the average pressure on the outflow.



The **Apply condition on each disjoint selection separately** checkbox is selected per default. When this setting is selected, the fully developed flow condition is applied separately on each disjoint selection. If this option is not selected, the condition is applied over the whole feature selection. The **Apply condition on each disjoint selection separately** should be disabled only if the flow conditions are known to be identical on each disjoint boundary.

The fully developed flow condition requires any volume force to be approximately aligned with the normal of the outlet boundary. The exception is gravity when the **Include gravity** setting is selected in the physics interface settings. Unless **Use reduced pressure** is also selected, an option to **Compensate for hydrostatic pressure** or **Compensate for hydrostatic pressure approximation** becomes available. It is selected per default and should only be deselected if the outlet normal is aligned with the gravity force and you want to specify an average pressure that includes the hydrostatic pressure.

### CONSTRAINT SETTINGS

This section is displayed by clicking the **Show** button (  ) and selecting **Advanced Physics Options**.

---

	Prescribing Inlet and Outlet Conditions
	Fully Developed Flow (Outlet)

---

## *Symmetry*

---

This node provides a boundary condition for symmetry boundaries. It should only be used when the geometry and expected solution have mirror symmetry. By using symmetries in a model its size can be reduced by one-half or more, making this an efficient tool for solving large problems.

The **Symmetry** boundary condition prescribes no penetration and vanishing shear stresses. The boundary condition is a combination of a Dirichlet condition and a Neumann condition:

$$\mathbf{u} \cdot \mathbf{n} = 0, \quad \left( -p\mathbf{I} + \mu(\nabla\mathbf{u} + (\nabla\mathbf{u})^T) - \frac{2}{3}\mu(\nabla \cdot \mathbf{u})\mathbf{I} \right) \mathbf{n} = \mathbf{0}$$

$$\mathbf{u} \cdot \mathbf{n} = 0, \quad (-p\mathbf{I} + \mu(\nabla\mathbf{u} + (\nabla\mathbf{u})^T))\mathbf{n} = \mathbf{0}$$

for the compressible and incompressible formulations. The Dirichlet condition takes precedence over the Neumann condition, and the above equations are equivalent to the following equation for both the compressible and incompressible formulations:

$$\mathbf{u} \cdot \mathbf{n} = 0, \quad \mathbf{K} - (\mathbf{K} \cdot \mathbf{n})\mathbf{n} = \mathbf{0}$$
$$\mathbf{K} = \mu(\nabla\mathbf{u} + (\nabla\mathbf{u})^T)\mathbf{n}$$

### **BOUNDARY SELECTION**

For 2D axial symmetry, a boundary condition does not need to be defined for the symmetry axis at  $r = 0$ . The software automatically provides a condition that prescribes  $u_r = 0$  and vanishing stresses in the  $z$  direction and adds an **Axial Symmetry** node that implements these conditions on the axial symmetry boundaries only.

### **CONSTRAINT SETTINGS**

This section is displayed by clicking the **Show** button (  ) and selecting **Advanced Physics Options**.

## *Open Boundary*

---

The **Open Boundary** condition describes boundaries in contact with a large volume of fluid. Fluid can both enter and leave the domain on boundaries with this type of condition.

## BOUNDARY CONDITIONS

The **Boundary condition** options for open boundaries are **Normal stress** and **No viscous stress**.

### *Normal Stress*

The **Normal stress**  $f_0$  condition implicitly imposes  $p \approx f_0$ .

When **Include gravity** is selected and **Use reduced pressure** not selected in the interface **Physical model** section, the **Compensate for hydrostatic pressure approximation** (named **Compensate for hydrostatic pressure** for incompressible flows) checkbox is available and selected by default. When it is selected, the hydrostatic pressure is automatically added to the pressure entered in  $f_0$  user input.

### *No Viscous Stress*

The **No Viscous Stress** condition specifies vanishing viscous stress on the boundary. This condition does not provide sufficient information to fully specify the flow at the open boundary and must at least be combined with pressure constraints at adjacent points.

The **No viscous stress** condition prescribes:

$$\left( \mu(\nabla \mathbf{u} + (\nabla \mathbf{u})^T) - \frac{2}{3}\mu(\nabla \cdot \mathbf{u})\mathbf{I} \right) \mathbf{n} = \mathbf{0}$$

$$\mu(\nabla \mathbf{u} + (\nabla \mathbf{u})^T) \mathbf{n} = \mathbf{0}$$

for the compressible and the incompressible formulations. This condition can be useful in some situations because it does not impose any constraint on the pressure. A typical example is a model with volume forces that give rise to pressure gradients that are hard to prescribe in advance. To make the model numerically stable, this boundary condition should be combined with a point constraint on the pressure.

### *Boundary Stress*

---

The **Boundary Stress** node adds a boundary condition that represents a general class of conditions also known as traction boundary conditions.

## BOUNDARY CONDITION

The **Boundary condition** options for the boundary stress are **General stress**, **Normal stress**, and **Normal stress, normal flow**.

### General Stress

When **General stress** is selected, the components for the **Stress  $\mathbf{F}$**  should be specified. The total stress on the boundary is set equal to the given stress  **$\mathbf{F}$** :

$$\left(-p\mathbf{I} + \mu(\nabla\mathbf{u} + (\nabla\mathbf{u})^T) - \frac{2}{3}\mu(\nabla \cdot \mathbf{u})\mathbf{I}\right)\mathbf{n} = \mathbf{F}$$

$$(-p\mathbf{I} + \mu(\nabla\mathbf{u} + (\nabla\mathbf{u})^T))\mathbf{n} = \mathbf{F}$$

for the compressible and the incompressible formulations.

This boundary condition implicitly sets a constraint on the pressure that for 2D flows is

$$p = 2\mu\frac{\partial u_n}{\partial n} - \mathbf{n} \cdot \mathbf{F} \quad (5-1)$$

If  $\partial u_n/\partial n$  is small, [Equation 5-1](#) states that  $p \approx -\mathbf{n} \cdot \mathbf{F}$ .

### Normal Stress

**Normal Stress** is described for the Open Boundary node.

#### Normal Stress, Normal Flow

For **Normal stress, normal flow**, the magnitude of the **Normal stress  $f_0$**  should be specified. The tangential velocity is set to zero on the boundary:

$$\mathbf{n}^T \left(-p\mathbf{I} + \mu(\nabla\mathbf{u} + (\nabla\mathbf{u})^T) - \frac{2}{3}\mu(\nabla \cdot \mathbf{u})\mathbf{I}\right)\mathbf{n} = -f_0, \quad \mathbf{t} \cdot \mathbf{u} = 0$$

$$\mathbf{n}^T (-p\mathbf{I} + \mu(\nabla\mathbf{u} + (\nabla\mathbf{u})^T))\mathbf{n} = -f_0, \quad \mathbf{t} \cdot \mathbf{u} = 0$$

for the compressible and the incompressible formulations.

This boundary condition implicitly sets a constraint on the pressure that for 2D flows is

$$p = 2\mu\frac{\partial u_n}{\partial n} + f_0 \quad (5-2)$$

If  $\partial u_n/\partial n$  is small, [Equation 5-2](#) states that  $p \approx f_0$ .

When **Include gravity** is selected and **Use reduced pressure** not selected in the interface **Physical model** section, the **Compensate for hydrostatic pressure approximation** (named **Compensate for hydrostatic pressure** for incompressible flows) checkbox is available and selected by default. When it is selected, the hydrostatic pressure is automatically added

to the pressure entered in  $f_0$  or  $p_{\text{hydro}}$  is added to  $\mathbf{F}$  depending on the selected option.

### CONSTRAINT SETTINGS

This section is displayed by clicking the **Show** button (  ) and selecting **Advanced Physics Options**.

If **Normal Stress, Normal Flow** is selected as the **Boundary condition**, then to **Apply reaction terms** on all dependent variables, the **All physics (symmetric)** option should be selected. Alternatively, the **Individual dependent variables** could be selected to restrict the reaction terms as needed.

### *Periodic Flow Condition*

---

The **Periodic Flow Condition** splits its selection into a source group and a destination group (the **Destination Selection** section is optional). Fluid that leaves the domain through one of the destination boundaries enters the domain through the corresponding source boundary. This corresponds to a situation where the geometry is a periodic part of a larger geometry. If the boundaries are not parallel to each other, the velocity vector is automatically transformed.

If the boundaries are curved, the orientation of the source must be specified manually (see [Orientation of Source](#)).

No input is required when **Compressible flow (Ma<0.3)** is selected for **Compressibility** under the **Physical Model** section for the physics interface. Typically when a periodic boundary condition is used with a compressible flow, the pressure is the same at both boundaries and the flow is driven by a volume force.

### BOUNDARY SELECTION



The software usually automatically identifies the boundaries as either source boundaries or destination boundaries, as indicated in the selection list. This works fine for cases like opposing parallel boundaries. In other cases, right-click **Periodic Flow Condition** and select **Manual Destination Selection** to control the destination. By default it contains the selection that COMSOL Multiphysics identifies.

### DESTINATION SELECTION

This section is available for specifying the destination boundaries, if needed, when the **Manual Destination Selection** option is selected in the context menu for the **Periodic Flow**

**Condition** node. You can only select destination boundaries from the union of all source and destination boundaries.

### FLOW CONDITION

This section is available when **Incompressible flow** is selected for **Compressibility** under the **Physical Model** section for the physics interface.

The **Flow Condition** at the boundary is specified through a value or expression for either the **Pressure difference**,  $p_{\text{src}} - p_{\text{dst}}$ , or the **Mass flow**,  $\dot{m}$ . The mass flow option ensures a pressure difference is achieved across the source and destination boundaries. This pressure difference can, for example, drive the fully developed flow in a channel.

To set up a periodic boundary condition, both boundaries must be selected in the **Periodic Flow Condition** node. COMSOL Multiphysics automatically assigns one boundary as the source and the other as the destination. To manually set the destination selection, a **Destination Selection** subnode is available from the context menu (by right-clicking the parent node) or from the **Physics** toolbar, **Attributes** menu. All destination sides must be connected.

### ORIENTATION OF SOURCE

To display this section, click the **Show More Options** button (  ) and select **Advanced Physics Options** in the **Show More Options** dialog. For information about the **Orientation of Source** section, see [Orientation of Source and Destination](#) in the *COMSOL Multiphysics Reference Manual*.

### ORIENTATION OF DESTINATION

This section appears if the setting for **Transform to intermediate map** in the **Orientation of Source** section is changed from the default value, **Automatic**, and **Advanced Physics Options** is selected in the **Show More Options** dialog. For information about the **Orientation of Destination** section, see [Orientation of Source and Destination](#) in the *COMSOL Multiphysics Reference Manual*.

### MAPPING BETWEEN SOURCE AND DESTINATION

To display this section, click the **Show More Options** button (  ) and select **Advanced Physics Options** in the **Show More Options** dialog. For information about the **Mapping Between Source and Destination** section, see [Mapping Between Source and Destination](#) in the *COMSOL Multiphysics Reference Manual*.

## *Porous Interface*

---

The **Porous Interface** condition is designed to properly account for a sudden jump in porosity,  $\epsilon_p$ , across a boundary between different domains. It describes possible discontinuity of stress across the interface, and also reveals modified behavior of tangential velocity due to boundary layer on the upstream side of the interface. Choose among the following options under the **Continuity conditions**:

- **Velocity and stress** — stress continuity is invoked;
- **Velocity and porosity-corrected stress** (default)— the sum of stress and a contribution due to the inertial term being constant across the interface;
- **Velocity and porosity-corrected stress with loss** — the sum of the stress and a contribution due to the inertial term is lost in the downstream direction.

All three options give continuity of the velocity across the interface in constant-density flows, while in case of a jump in density:

- 1 give continuity of the mass flux (product of density and normal velocity) and tangential velocity;
- 2 account for the density-jump correction in the stress condition.

When **Velocity and porosity-corrected stress with loss** is chosen, a **Pressure loss model** needs to be specified. The options are:

- **User-defined loss coefficients** (default). Enter values for **Expansion loss coefficient** and **Contraction loss coefficient**;
- **Borda–Carnot**. Specify **Vena contracta model**.

**Vena contracta model** allows two options:

- **User defined** (default) — enter value of **Vena contracta coefficient**;
- **Weisbach** — enter values of **Lower limit** and **Exponent**.

Notice that the notions ‘expansion’ and ‘contraction’ used in this section correspond not to geometrical changes, but to the variations of the microscopic structure across the interface in the flow direction — increasing or decreasing porosity,  $\epsilon_p$ , respectively.

## *Flow Continuity*

---

The **Flow Continuity** condition is suitable for pairs where the boundaries match; it prescribes that the flow field is continuous across the pair.

The parts of the boundary where a source boundary lacks a corresponding destination boundary and vice versa will get conditions from other boundary conditions under the physics interface acting as fallback boundary conditions on the nonoverlapping parts. By default, the [Wall](#) node is used as fallback unless another feature has been selected for the boundary. When the condition is set for pairs adjacent to domains with different porosity  $\epsilon_p$ , it imposes conditions identical to the **Porous Interface** feature, which is designed to properly account for a sudden jump in porosity. See the section [Porous Interface](#) above for further details (note that the **Flow Continuity** does not account for the density-jump corrections),



About Pairs

---

### *Pressure Point Constraint*

---

The **Pressure Point Constraint** condition can be used to specify the pressure level. If it is not possible to specify the pressure level using a boundary condition, the pressure level must be set in some other way, for example, by specifying a fixed pressure at a point.

#### **PRESSURE CONSTRAINT**

The relative pressure value is set by specifying the **Pressure**  $p_0$ . If the reference pressure  $p_{\text{ref}}$  defined at the physics interface level is equal to zero,  $p_0$  represents the absolute pressure.

When **Include gravity** is selected and **Use reduced pressure** not selected in the interface **Physical model** section, the **Compensate for hydrostatic pressure approximation** (named **Compensate for hydrostatic pressure** for incompressible flows) checkbox is available and selected by default. When it is selected, the hydrostatic pressure is automatically added to the pressure entered in  $p_0$  user input.

#### **CONSTRAINT SETTINGS**

This section is displayed by clicking the **Show** button (  ) and selecting **Advanced Physics Options**.

The **Apply reaction terms on** setting is set per default to **Individual dependent variables**. **All physics (symmetric)** cannot be used together with a segregated solver when fluid flow is coupled with Moving Mesh, Level Set, or Phase Field in Fluids.

## *Average Pressure*

---

The **Average Pressure** condition can be used to specify the pressure level. If it is not possible to specify the pressure level using a boundary condition, the pressure level must be set in some other way, for example, by specifying an average pressure in all flow domains.

### **AVERAGE PRESSURE CONSTRAINT**

The relative average pressure is set by specifying the **Average pressure**  $p_{\text{ave}}$ . If the reference pressure  $p_{\text{ref}}$  defined at the physics interface level is equal to zero,  $p_{\text{ave}}$  represents the average absolute pressure.

When **Include gravity** and **Use reduced pressure** are selected, the average reduced pressure is constrained to  $p_{\text{ave}}$ .



The **Average Pressure** constraint couples all the degrees of freedom for the pressure. This could lead to large memory usage and ill-conditioned systems. In such cases, consider using a **Pressure Point Constraint** instead.

---

## *Point Mass Source*

---

This feature requires at least one of the following licenses: Battery Design Module, CFD Module, Chemical Reaction Engineering Module, Corrosion Module, Electrochemistry Module, Electrodeposition Module, Fuel Cell & Electrolyzer Module, Microfluidics Module, Pipe Flow Module, or Subsurface Flow Module.

The **Point Mass Source** feature models mass flow originating from an infinitely small domain centered around a point.

For the Reacting Flow in Porous Media, Diluted Species interface, which is available with the CFD Module, Chemical Reaction Engineering Module, or Battery Design Module, there are two nodes: one for the fluid flow (**Fluid Point Source**) and one for the species (**Species Point Source**).

### **SOURCE STRENGTH**

The source **Mass flux**,  $\dot{q}_p$ , should be specified. A positive value results in mass being ejected from the point into the computational domain. A negative value results in mass being removed from the computational domain.

Point sources located on a boundary or on an edge affect the adjacent computational domains. This has the effect, for example, that a point source located on a symmetry plane has twice the given strength.



Mass Sources for Fluid Flow in the *COMSOL Multiphysics Reference Manual*

### *Line Mass Source*

This feature requires at least one of the following licenses: Battery Design Module, CFD Module, Chemical Reaction Engineering Module, Corrosion Module, Electrochemistry Module, Electrodeposition Module, Fuel Cell & Electrolyzer Module, Microfluidics Module, Pipe Flow Module, or Subsurface Flow Module.

The **Line Mass Source** feature models mass flow originating from a tube region with infinitely small radius.

For the Reacting Flow in Porous Media, Diluted Species interface, which is available with the CFD Module, Chemical Reaction Engineering Module, or Battery Design Module, there are two nodes, one for the fluid flow (**Fluid Line Source**) and one for the species (**Species Line Source**).

#### **SELECTION**

The **Line Mass Source** feature is available for all dimensions, but the applicable selection differs between the dimensions.

MODEL DIMENSION	APPLICABLE GEOMETRICAL ENTITY
2D	Points
2D Axisymmetry	Points not on the axis of symmetry
3D	Edges

#### **SOURCE STRENGTH**

The source **Mass flux**,  $\dot{q}_1$ , should be specified. A positive value results in mass being ejected from the line into the computational domain and a negative value means that mass is removed from the computational domain.

Line sources located on a boundary affect the adjacent computational domains. This, for example, has the effect that a line source located on a symmetry plane has twice the given strength.



Mass Sources for Fluid Flow in the *COMSOL Multiphysics Reference Manual*

## *Gravity*

The **Gravity** global feature is automatically added when **Include gravity** is selected at the interface level in the **Physical Model** settings. It defines the gravity forces from the **Acceleration of gravity** value.

### **ACCELERATION OF GRAVITY**

The **Acceleration of gravity** (SI unit m/s, default value  $-g_{\text{const}}\mathbf{e}_z$  in 2D axial symmetry and 3D and  $-g_{\text{const}}\mathbf{e}_y$  in 2D) is used to define the gravity forces. It should be a global quantity.

When in addition to **Include gravity** also **Rotating frame** is selected (only possible in 3D and 2D axial symmetry), the **Project gravity vector on rotation axis** checkbox is available (by default selected).

## *Rotating Frame*

The **Rotating Frame** global feature is automatically added when **Rotating frame** is selected at the interface level in the **Physical Model** settings. It defines the fictitious Coriolis, centrifugal and Euler forces from the settings in the **Rotating Frame** section.

### **ROTATING FRAME**

In 2D, the axis of rotation is an out-of-plane axis. In this case, select a **Rotation axis base point**  $\mathbf{r}_{\text{bp}}$ .

In 2D axial symmetry, the axis of rotation is the symmetry axis.

In 3D, select an **Axis of rotation** — **x-axis**, **y-axis**, **z-axis** (the default), or **User defined**. For **User defined** enter a **Rotation axis direction**  $\mathbf{e}_{\text{ax}}$  and a **Rotation axis base point**  $\mathbf{r}_{\text{bp}}$ .



Select a **Rotation speed** — **Angular velocity**, **Revolutions per time**, or **User defined**.

- For **Angular velocity**, enter a value for the angular velocity magnitude  $\Omega_f$ .

- For **Revolutions per time**, enter an RPM value.
- For **User defined**, enter the **Rotation angle**  $\alpha$  in radians as function of time (the variable  $t$ ).

In case **Angular velocity** or **Revolutions per time** is selected, also select a **Rotational direction** — **Counterclockwise** (the default) or **Clockwise**.

# The Darcy's Law Interface

The **Darcy's Law (dl)** interface (  ), found under the **Porous Media and Subsurface Flow** branch (  ) when adding a physics interface, is used to simulate fluid flow through interstices in a porous medium. It can be used to model low-velocity flows or media where the permeability and porosity are very small, and for which the pressure gradient is the major driving force and the flow is mostly influenced by the frictional resistance within the pores. Set up multiple **Darcy's Law** interfaces to model multiphase flows involving more than one mobile phase. The Darcy's Law interface can be used for stationary and time-dependent analyses.

The main feature is the **Porous Medium Properties** node, which provides interfaces for defining the fluid material and the porous matrix properties.

When this physics interface is added, the following default nodes are also added in the **Model Builder — Porous Medium, No Flow** (the default boundary condition), and **Initial Values**. Then, from the **Physics** toolbar, add other nodes that implement, for example, boundary conditions and mass sources. You can also right-click **Darcy's Law** to select physics features from the context menu.

## SETTINGS

The **Label** is the default physics interface name.

The **Name** is used primarily as a scope prefix for variables defined by the physics interface. Refer to such physics interface variables in expressions using the pattern `<name>.<variable_name>`. In order to distinguish between variables belonging to different physics interfaces, the `name` string must be unique. Only letters, numbers, and underscores (`_`) are permitted in the **Name** field. The first character must be a letter.

The default **Name** (for the first physics interface in the model) is `dl`.

## PHYSICAL MODEL

Enter a **Reference pressure level**  $p_{\text{ref}}$  (SI unit: Pa). The default value is `1 [atm]`.

## GRAVITY EFFECTS

By default there are no gravity effects added to Darcy's Law interface. Select the checkbox **Include gravity** to activate the acceleration of gravity. When this checkbox is selected, a global **Gravity** feature node is shown in the interface model tree.

Enter a value for the acceleration of gravity. The default value `g_const` is the predefined standard acceleration of gravity on earth.



For a detailed overview of the functionality available in each product, visit [www.comsol.com/products/specifications/](http://www.comsol.com/products/specifications/).

---

## DISCRETIZATION

To display all settings available in this section, click the **Show More Options** button (  ) and select **Advanced Physics Options** in the **Show More Options** dialog.

You can choose the order of the shape functions used for the pressure variable solved by the Darcy's Law interface. The default shape functions are **Quadratic** Lagrange.

The **Compute boundary fluxes** checkbox is not activated by default. When this option is selected, the solver computes variables storing accurate boundary fluxes from each boundary into the adjacent domain.

If the checkbox is cleared, the COMSOL Multiphysics software instead computes the flux variables from the dependent variables using extrapolation, which is less accurate in postprocessing results but does not create extra dependent variables on the boundaries for the fluxes.

Also, the **Apply smoothing to boundary fluxes** checkbox is available if the previous checkbox is selected. The smoothing can provide a better behaved flux value close to singularities.



For details about the boundary fluxes settings, see [Computing Accurate Fluxes](#) in the *COMSOL Multiphysics Reference Manual*.

The **Value type when using splitting of complex variables** setting should in most pure mass transport problems be set to **Real** which is the default. It makes sure that the dependent variable does not get affected by small imaginary contributions, which can occur, for example, when combining a Time Dependent or Stationary study with a frequency-domain study. For more information, see [Splitting Complex-Valued Variables](#) in the *COMSOL Multiphysics Reference Manual*.

## DEPENDENT VARIABLES

The dependent variable (field variable) is the **Pressure**. The name can be changed but the names of fields and dependent variables must be unique within a model.

---

	<ul style="list-style-type: none"><li>• <a href="#">Domain, Boundary, Edge, Point, and Pair Nodes for the Darcy's Law Interface</a></li><li>• <a href="#">Theory for the Darcy's Law Interface</a></li><li>• <a href="#">Physical Constants</a> in the <i>COMSOL Multiphysics Reference Manual</i></li></ul>
	<ul style="list-style-type: none"><li>• <i>Species Transport in the Gas Diffusion Layers of a PEM</i>: Application Library path <b>Fuel_Cell_and_Electrolyzer_Module/Fuel_Cells/pem_gdl_species_transport_2d</b></li><li>• <i>Steam Reformer</i>: Application Library path <b>Chemical_Reaction_Engineering_Module/Reactors_with_Porous_Catalysts/steam_reformer</b></li><li>• <i>Terzaghi Compaction</i>: Application Library path <b>Subsurface_Flow_Module/Poromechanics/terzaghi_compaction</b></li></ul>

---

### *Domain, Boundary, Edge, Point, and Pair Nodes for the Darcy's Law Interface*

---

The [Darcy's Law Interface](#) has the following domain, boundary, edge, point, and pair nodes, these nodes are available from the **Physics** ribbon toolbar (Windows users), **Physics** context menu (Mac or Linux users), or right-click to access the context menu (all users).

## DOMAIN

- Porous Medium
- Unsaturated Porous Medium
- Dual Porosity Medium
- Dual Permeability Medium
- Unsaturated Dual Permeability Medium
- Mass Source
- Cross Section
- Initial Values
- Unsaturated Porous Medium
- ThicknessContributing Velocity
- Porous Electrode Coupling

## BOUNDARY, EDGE, AND POINT

The following nodes (listed in alphabetical order) are available on exterior boundaries:

- Atmosphere/Gauge
- Electrode–Electrolyte Interface Coupling
- Flux Discontinuity
- Fracture
- Hydraulic Head
- Inlet
- Interior Wall
- Line Mass Source
- Mass Flux
- No Flow
- Outlet
- Periodic Condition
- Pervious Layer
- Point Mass Source
- Precipitation
- Pressure
- Pressure Head
- Reaction Coefficients<sup>1</sup>
- Symmetry
- Barrier

<sup>1</sup> This node is described for the Transport of Diluted Species Interface

The relevant physics interface condition at interior boundaries is continuity:

$$\mathbf{n} \cdot (\rho_1 \mathbf{u}_1 - \rho_2 \mathbf{u}_2) = 0$$

The continuity boundary condition ensures that the pressure and mass flux are continuous. In addition, the [Pressure](#) boundary condition is available on interior boundaries.

The continuity boundary condition provides continuity for the pressure and mass flux. In addition, the following boundary conditions are available on interior boundaries:

- Pressure
- Pressure Head
- Hydraulic Head
- Interior Wall
- Pervious Layer
- Flux Discontinuity
- Fracture
- Barrier



Note that some of the above-mentioned domain or boundary conditions are only available with some products. For a detailed overview of the functionality available in each product, visit [www.comsol.com/products/specifications/](http://www.comsol.com/products/specifications/)



In general, to add a node, go to the **Physics** toolbar, no matter what operating system you are using. Subnodes are available by clicking the parent node and selecting it from the **Attributes** menu.



For axisymmetric components, COMSOL Multiphysics takes the axial symmetry boundaries (at  $r = 0$ ) into account and automatically adds an **Axial Symmetry** node that is valid on the axial symmetry boundaries only.



In the *COMSOL Multiphysics Reference Manual* see [Table 2-4](#) for links to common sections and [Table 2-5](#) to common feature nodes. You can also search for information: press F1 to open the **Help** window or Ctrl+F1 to open the **Documentation** window.

### *Porous Medium*

The **Porous Medium** node adds the equations for modeling flow through porous domains. By default these are [Equation 5-3](#) and [Equation 5-4](#) (excluding any mass sources).

$$\frac{\partial}{\partial t}(\varepsilon_p \rho) + \nabla \cdot (\rho \mathbf{u}) = Q_m \quad (5-3)$$

$$\mathbf{u} = -\frac{\kappa}{\mu}\nabla p \quad (5-4)$$

For a steady-state problem the first term in Equation 5-3 disappears. When **Mass Source** is active Equation 5-4 is of the following form:

$$\mathbf{u} = -\frac{\kappa}{\mu}(\nabla p - \rho\mathbf{g}) \quad (5-5)$$

The **Porous Medium** feature has two default subfeatures — the **Fluid** subfeature where the fluid density  $\rho$  (SI unit:  $\text{kg}/\text{m}^3$ ) and dynamic viscosity  $\mu$  (SI unit:  $\text{Pa}\cdot\text{s}$ ) are defined and the **Porous Matrix** subfeature where the permeability  $\kappa$  (SI unit:  $\text{m}^2$ ) and porosity  $\epsilon_p$  (dimensionless) are specified.

### COORDINATE SYSTEM SELECTION

Select a coordinate system from the **Coordinate system** list for the interpretation of directions in anisotropic material properties. The default is the **Global coordinate system**, and the list contains any additional orthonormal coordinate system (except boundary coordinate systems) added under the **Definitions** node.

The subnodes inherit these coordinate system settings. In particular, the **Permeability** or **Hydraulic conductivity** (in the **Porous Matrix** subnode) should be set according to the coordinate system selected in this section.

### FLOW MODEL

Define if the flow follows a linear or nonlinear pressure-velocity relationship.

- **Darcian flow** (default) defines a linear relationship using Equation 5-3 and Equation 5-4.
- **Non-Darcian flow** defines a nonlinear relationship using Equation 5-3 and

$$\nabla p = -\frac{\mu}{\kappa}\mathbf{u} - \beta\rho|\mathbf{u}|\mathbf{u}$$

where the nonlinear parameter  $\beta$  (SI unit:  $1/\text{m}$ ) is further specified in the **Porous Matrix** subfeature.

### STORAGE MODEL

Define the time dependent storage term by selecting one of the following options from the list:

- **From density and porosity** (default), uses the formulation of Equation 5-3

- **Linearized storage**, where the following linear equation is used to define the storage:

$$S_p = \varepsilon_p \chi_f + (1 - \varepsilon_p) \chi_p$$

- **Poroelastic storage**, where  $S_p = \varepsilon_p \chi_f$
- **Quasistatic**, where the storage term is set to zero
- **User defined** to directly specify the storage coefficient  $S_p$



- [Porous Material](#) in the *COMSOL Multiphysics Reference Manual*
- [About Darcian and Non-Darcian Flow](#) in the *Porous Media Flow Module User's Guide*
- [Storage Models](#) in the *Subsurface Flow Module User's Guide*



Note that some options are only available in some modules. For a detailed overview of the functionality available in each product, visit [www.comsol.com/products/specifications/](http://www.comsol.com/products/specifications/)

## LOCATION IN USER INTERFACE

*Context Menus*

**Darcy's Law > Porous Medium**

**Richards' Equation > Porous Medium**

*Ribbon*

Physics tab with *interface* as **Darcy's Law** or **Richards' Equation** selected:

**Domains > interface > Porous Medium**

*Fluid*

This node defines the material properties of the fluid of the [Porous Medium](#), the [Unsaturated Porous Medium](#), the [Dual Porosity Medium](#), the [Dual Permeability Medium](#), or the [Unsaturated Porous Medium](#) parent node.

## MODEL INPUT

This section contains fields and values that are inputs for expressions defining material properties. If such user-defined property groups are added, the model inputs appear here.

## FLUID PROPERTIES

The available options for the **Fluid type** are **Incompressible**, **Compressible**, **Compressible, linearized**, or **Ideal gas**. The selection determines how the density and compressibility of the fluid are set.

### *Incompressible*

The default **Reference density**  $\rho_{\text{ref}}$  uses values **From material**. For **User defined** enter another value or expression.

### *Compressible*

The default **Density**  $\rho$  uses values **From material**. For **User defined** enter another value or expression as a function of the absolute pressure. The compressibility of the fluid is computed from it.

### *Compressible, Linearized*

The default **Reference density**  $\rho_{\text{ref}}$  and the **Fluid compressibility**  $\chi_f$  use values **From material**. For **User defined** enter another value or expression. The fluid density increases linearly as a function of the fluid pressure.

### *Ideal Gas*

For **Ideal gas** it uses the ideal gas law to describe the gas density. In this case, specify the thermodynamics properties. Select a **Gas constant type** — **Specific gas constant**  $R_s$  (the default) or **Mean molar mass**  $M_n$  (SI unit: J/(mol·K)). For **Mean molar mass** the universal gas constant  $R = 8.314$  J/(mol·K) is used as the built-in physical constant. For both properties, the defaults use values **From material**. For **User defined** enter another value or expression.

### *Dynamic Viscosity*

For all fluid types specify the **Dynamic viscosity**  $\mu$  (SI unit: Pa·s) uses values **From material**. For **User defined** enter another value or expression.

### *Constitutive Relation*

The Polymer Flow Module allows the use of inelastic non-Newtonian models. For Darcian Flow, you can choose between two options: **Specify dynamic viscosity** (default) or **Inelastic non-Newtonian**. Use the default option to either get the dynamic viscosity from a material, or to add a user defined expression. The default option lets you either use the dynamic viscosity from a material or define it with a custom expression. The **Inelastic non-Newtonian** option provides several models and defines the **Apparent shear rate**.

### *Inelastic Non-Newtonian*

The following inelastic non-Newtonian Models are available for the **Fluid** feature under the **Porous Medium** feature:

- Power Law
- Carreau
- Carreau–Yasuda
- Cross
- Cross–Williamson
- Sisko

The setup of these models in porous media is similar to their definition under the [Fluid Properties](#) feature.

### *Apparent Shear Rate*

To define the apparent shear rate  $\dot{\gamma}_{app}$ , either enter a user-defined expression for the correction factor ( $\alpha$ ) or choose the **Capillary bundle approach** from the list and provide a value for the Tortuosity factor ( $C$ ).



- Read more about the theory of [Non-Newtonian Fluids in Porous Media](#) in the *Polymer Flow Module User's Guide*

---

### **LOCATION IN USER INTERFACE**

A default **Fluid** node is automatically added to the [Porous Medium](#), the [Unsaturated Porous Medium](#), the [Dual Porosity Medium](#), the [Dual Permeability Medium](#), and the [Unsaturated Dual Permeability Medium](#) node.

### *Context Menus*

**Darcy's Law** > *porous medium feature* > **Fluid**

**Richards' Equation** > *porous medium feature* > **Fluid**

### *Porous Matrix*

---

This node defines the porosity and material properties of the solid matrix of the [Porous Medium](#) or [Unsaturated Porous Medium](#) parent node.

## MODEL INPUT

This section contains fields and values that are inputs for expressions defining material properties. If such user-defined property groups are added, the model inputs appear here.

## MATRIX PROPERTIES

The default **Porosity**  $\epsilon_p$  of the solid matrix is taken **From material**. In a **Porous Material** node, the porosity is defined as follows:

$$\epsilon_p = 1 - \sum_i \theta_{si} - \sum_i \theta_{imfi}$$

where  $\theta_{si}$  and  $\theta_{imfi}$  are the porosities of the **Solid** and **Immobile Fluids** subnodes under the **Porous Material** node. See [Porous Material](#) in the *COMSOL Multiphysics Reference Manual* for more information.

Select **User defined** to enter a value or expression for  $\epsilon_p$ .

If required by a **Storage model** in the parent node, specify the **Effective compressibility** of the porous matrix. The default value is  $\chi_p = 10^{-4}$  1/Pa.

Select a **Permeability model** to specify the capacity of the porous material to transmit flow. Which options are available depends on the **Flow model** setting in the parent node. Note that for the [Unsaturated Porous Medium](#) parent node only the Darcian Flow models are available.

### *Darcian Flow*

If **Darcian flow** is selected in the parent **Porous medium** node, select between the following options for the **Permeability model**:

- Select **Permeability** (default) to define the permeability of the porous matrix. The default **Permeability**  $\kappa$  (SI unit:  $\text{m}^2$ ) uses the value **From material**, as defined by the **Porous material**. For **User defined** select **Isotropic** to define a scalar value or **Diagonal** or **Symmetric** to define a tensor value.
- Select **Hydraulic conductivity** or define a combination of fluid permeability and dynamic viscosity. For **Hydraulic conductivity**  $K$  (SI unit: m/s) select **Isotropic** to define a scalar value or **Diagonal** or **Symmetric** to define a tensor value. The default is  $2.94 \cdot 10^{-4}$  m/s.

- Select **Kozeny–Carman** to define the permeability from the porosity and mean particle diameter. Enter the mean **Particle diameter**  $d_p$  (SI unit: m), the default value is 0.5 mm.
- Select **Power law** to define the permeability as an exponential function of the porosity:  $\kappa = b_{PI} \varepsilon_p^n$ , where  $b_{PI}$  and  $n$  are empirical parameters. Enter the proportionality factor  $b_{PI}$  (SI unit:  $m^2$ ) and the exponent  $n$  (dimensionless).

#### Non-Darcian Flow

If **Non-Darcian flow** is selected in the parent node, select between the following options for the **Permeability model**:

- For **Forchheimer**, the default **Permeability**  $\kappa$  (SI unit:  $m^2$ ) uses the value **From material**. Furthermore, the dimensionless **Forchheimer parameter**  $c_F$  can be defined. The default value is 0.55.
- If **Ergun** is selected, enter the mean **Particle diameter**  $d_p$  (default value: 0.5 mm).
- For **Burke–Plummer**, specify the mean **Particle diameter**  $d_p$  (default value: 0.5 mm).
- For **Klinkenberg**, the default **Permeability**  $\kappa_\infty$  (SI unit:  $m^2$ ) uses the value **From material**. Enter the **Klinkenberg parameter**  $b_K$ . Its default value is  $10^3$  Pa.
- For **User defined**, the default **Permeability**  $\kappa$  (SI unit:  $m^2$ ) uses the value **From material**. In addition, the **Inertial resistance coefficient**  $\beta$  (SI unit:  $1/m$ ) can be defined. Its default value is zero.



- [About Darcian and Non-Darcian Flow](#) in the *Porous Media Flow Module User's Guide*
- [Permeability Models](#) in the *Porous Media Flow Module User's Guide*



Note that some options are only available in some modules. For a detailed overview of the functionality available in each product, visit [www.comsol.com/products/specifications/](http://www.comsol.com/products/specifications/)

#### RETENTION MODEL

For an **Unsaturated Porous Medium** select between the following options for the retention model:

- **van Genuchten**, to specify the retention model using the van Genuchten relationship. Enter the constitutive relation constants  $\alpha$  (the default value is 1, and the SI unit is

1/m),  $n$  (default value is 2), and  $l$  (default value is 0.5). The constitutive parameter  $m$  is equal to  $1 - 1/n$ .

- **Brooks and Corey** to use the retention model according to the Brooks and Corey relationships.
- **User defined** to use a different retention model. Enter user defined expressions for the **Effective saturation**  $S_e$ , the **Liquid volume fraction**  $\theta_l$ . The default is  $\epsilon_p$  (the porosity variable). Specify the **Specific moisture capacity**  $C_m$  (SI unit: 1/m). The default value is 0 (1/m). Enter an expression for the **Relative permeability**  $\kappa_r$ . The default value is 1.

If there is a residual volume of liquid that cannot move through the pore network, also enter a value between 0 and 1 for the **Residual liquid volume fraction**  $\theta_r$ . The default value is 0.



Retention and Permeability Relationships in the *Subsurface Flow Module*  
User's Guide

#### LOCATION IN USER INTERFACE

A default **Porous Matrix** node is automatically added to **Porous Medium** or the **Unsaturated Porous Medium** node.

*Context Menus*

**Darcy's Law** > *porous medium feature* > **Fluid**

**Richards' Equation** > *porous medium feature* > **Fluid**

#### *Unsaturated Porous Medium*

The **Unsaturated Porous Medium** node adds Richards' equation (Equation 5-6) for flow in variably saturated porous media.

$$\rho \left( \frac{C_m}{\rho g} + S_e S_p \right) \frac{\partial p}{\partial t} + \nabla \cdot \rho \left( -\frac{\kappa_r \kappa}{\mu} (\nabla p + \rho g \nabla D) \right) = Q_m \quad (5-6)$$

The **Unsaturated Porous Medium** feature has two default subfeatures: the **Fluid** subfeature, where the fluid density  $\rho$  (SI unit: kg/m<sup>3</sup>) and viscosity  $\mu$  (SI unit: Pa·s) are defined, and the **Porous Matrix** subfeature, where the permeability  $\kappa$  (SI unit: m<sup>2</sup>) and porosity  $\epsilon_p$  (dimensionless) are specified as well as the retention model.

## COORDINATE SYSTEM SELECTION

Select a coordinate system from the **Coordinate system** list for the interpretation of directions in anisotropic material properties. The default is the **Global coordinate system**, and the list contains any additional orthonormal coordinate system (except boundary coordinate systems) added under the **Definitions** node.

The subnodes inherit these coordinate system settings. In particular, the **Permeability** or **Hydraulic conductivity** (in the **Porous Matrix** subnode) should be set according to the coordinate system selected in this section.

## STORAGE MODEL

With this option, define the first term in Equation 5-6. Therefore, choose from a list one of the following formulations:

- From retention model
- Linearized storage (default)
- From liquid content
- User defined

If **From retention model** is chosen, the first term of Equation 5-6 accounts only for the specific moisture capacity  $C_m$  which is defined by the **Retention Model** in the **Porous Matrix** subnode:

$$\frac{C_m \partial p}{g \partial t}.$$

For the option **Linearized storage** the storage coefficient  $S_p$  in Equation 5-6 is defined as

$$S_p = \varepsilon_p \chi_f + (1 - \varepsilon_p) \chi_p.$$

**From liquid content** enforces the first term of Equation 5-6 to be defined in terms of liquid volume fraction as

$$\frac{\partial(\rho \theta_l)}{\partial t}$$

and the **User defined** option allows to define the storage coefficient  $S_p$  in [Equation 5-6](#) directly.



Note that some options are only available in some modules. For a detailed overview of the functionality available in each product, visit [www.comsol.com/products/specifications/](http://www.comsol.com/products/specifications/)

## LOCATION IN USER INTERFACE

*Context Menus*

**Darcy's Law > Unsaturated Porous Medium**

**Richards' Equation > Unsaturated Porous Medium**

*Ribbon*

Physics tab with *interface* as **Darcy's Law** or **Richards' Equation** selected:

**Domains > interface > Unsaturated Porous Medium**

### *Dual Porosity Medium*

Use the Dual Porosity Medium if the flow through macropores is governed by Darcy's law and the micropores do not significantly contribute to the overall flow in the porous medium.

The feature has three default subfeatures —the **Fluid** subfeature where the fluid density  $\rho$  (SI unit:  $\text{kg}/\text{m}^3$ ) and dynamic viscosity  $\mu$  (SI unit:  $\text{Pa}\cdot\text{s}$ ) are defined, the **Macropores** subfeature where the hydraulic properties of the macroporous matrix are defined, and the **Micropores** where the hydraulic properties of the microporous matrix are defined.

## COORDINATE SYSTEM SELECTION

Select a coordinate system from the **Coordinate system** list for the interpretation of directions in anisotropic material properties. The default is the **Global coordinate system**, and the list contains any additional orthonormal coordinate system (except boundary coordinate systems) added under the **Definitions** node.

The subnodes inherit these coordinate system settings. In particular, the **Permeability** or **Hydraulic conductivity** (in the **Macropores** and **Micropores** subnodes) should be set according to the coordinate system selected in this section.

## STORAGE MODEL

Choose from a list one of the following formulations:

- **From density and porosity** (default), uses the formulation equivalent to [Equation 5-3](#)
- **Linearized storage**, where the following linear equation is used to define the storage in the macropores as  $S_p = \varepsilon_p \chi_f + (1 - \varepsilon_p) \chi_p$  and in the micropores as  $S_{p,m} = \varepsilon_{p,m} \chi_f + (1 - \varepsilon_{p,m}) \chi_p$ .
- **Poroelastic storage**, where  $S_p = \varepsilon_p \chi_f$  in the macropores and  $S_{p,m} = \varepsilon_{p,m} \chi_f$  in the micropores.
- **Quasistatic**, where the storage term is set to zero
- **User defined** to directly specify the storage coefficient  $S_p$  and  $S_{p,m}$  for the macro- and micropores respectively.



- [Storage Models](#) in the *Subsurface Flow Module User's Guide*

---

## INTERPOROSITY FLOW

Specify the **Fluid Transfer Function**  $\alpha_w$  which is used to calculate the interporosity flow, the mass exchange between macro- and microscale system:

$$Q_{ip} = \alpha_w (p_M - p_m) \quad (5-7)$$

with  $p_M$  being the pressure within the macropores and  $p_m$  the pressure within the micropores.



Find more information in the *Subsurface Flow Module User's Guide*

- [Dual Porosity & Dual Permeability Modeling](#)
- [Dual Porosity and Dual Permeability Theory](#)



Note that some options are only available in some modules. For a detailed overview of the functionality available in each product, visit [www.comsol.com/products/specifications/](http://www.comsol.com/products/specifications/)

## LOCATION IN USER INTERFACE

*Context Menus*

**Darcy's Law > Dual Porosity/Permeability > Dual Porosity Medium**

**Richards' Equation > Dual Porosity/Permeability > Dual Porosity Medium**

*Ribbon*

Physics tab with **Darcy's Law** or **Richards' Equation** selected:

**Domains > Dual Porosity/Permeability > Dual Porosity Medium**

### *Dual Permeability Medium*

---

Use the **Dual Permeability Medium** feature to model transport in a saturated dual permeability medium where Darcy's Law describes the transport in each system.

The feature has three default subfeatures—the **Fluid** subfeature where the fluid density  $\rho$  (SI unit:  $\text{kg}/\text{m}^3$ ) and dynamic viscosity  $\mu$  (SI unit:  $\text{Pa}\cdot\text{s}$ ) are defined, the **Macropores** subfeature where the hydraulic properties of the macroporous matrix are defined, and the **Micropores** where the hydraulic properties of the microporous matrix are defined.

## COORDINATE SYSTEM SELECTION

Select a coordinate system from the **Coordinate system** list for the interpretation of directions in anisotropic material properties. The default is the **Global coordinate system**, and the list contains any additional orthonormal coordinate system (except boundary coordinate systems) added under the **Definitions** node.

The subnodes inherit these coordinate system settings. In particular, the **Permeability** or **Hydraulic conductivity** (in the **Macropores** and **Micropores** subnodes) should be set according to the coordinate system selected in this section.

## STORAGE MODEL

With this option under the **Porous Medium** section, [Equation 5-3](#) is formulated with respect to a storage term (analogous to [Equation 4-4](#)). Therefore, choose from a list one of the following formulations:

- **From density and porosity** (default), uses the formulation of [Equation 4-4](#)
- **Linearized storage**, where the following linear equation is used to define the storage:

$$S_{p,i} = \varepsilon_{p,i}\chi_f + (1 - \varepsilon_{p,i})\chi_{p,i}$$

with  $i=M$  for the macropores and  $i=m$  for the micropores.

- **Poroelastic storage**, where  $S_{p,i} = \varepsilon_{p,i}\chi_f$
- **Quasistatic**, where the storage term is set to zero
- **User defined** to directly specify the storage coefficient  $S_p$



• [Storage Models](#) in the *Subsurface Flow Module User's Guide*

### INTERPOROSITY FLOW

Specify the **Fluid Transfer Function**  $\alpha_w$  which is used to calculate the interporosity flow, which is the mass exchange between macro- and microscale system:

$$Q_{ip} = \alpha_w(p_M - p_m) \quad (5-8)$$

with  $p_M$  being the pressure in the macropores and  $p_m$  the pressure in the micropores.



Find more information in the *Subsurface Flow Module User's Guide*

- [Dual Porosity & Dual Permeability Modeling](#)
- [Dual Porosity and Dual Permeability Theory](#)



Note that some options are only available in some modules. For a detailed overview of the functionality available in each product, visit [www.comsol.com/products/specifications/](http://www.comsol.com/products/specifications/)

### LOCATION IN USER INTERFACE

*Context Menus*

**Darcy's Law > Dual Porosity/Permeability > Dual Permeability Medium**

**Richards' Equation > Dual Porosity/Permeability > Dual Permeability Medium**

*Ribbon*

Physics tab with **Darcy's Law** or **Richards' Equation** selected:

**Domains > Dual Porosity/Permeability > Dual Permeability Medium**

## Unsaturated Dual Permeability Medium

---

Use the **Unsaturated Dual Permeability Medium** feature to model the transport in an unsaturated dual permeability medium where Richards' Equation (Equation 5-6) describes the transport in each system.

$$\begin{aligned}\theta_M \left( \rho \left( S_{c,M} S_{p,M} + \frac{C_{m,M}}{\rho g} \right) \frac{\partial p_M}{\partial t} + \nabla(\rho \mathbf{u}_M) \right) &= -Q_{ip} + \theta_M Q_m \\ (1 - \theta_M) \left( \rho \left( S_{c,m} S_{p,m} + \frac{C_{m,m}}{\rho g} \right) \frac{\partial p_m}{\partial t} + \nabla(\rho \mathbf{u}_m) \right) &= Q_{ip} + (1 - \theta_M) Q_m \\ p &= \theta_M p_M + (1 - \theta_M) p_m\end{aligned}\tag{5-9}$$

$\theta_M$  is the volume fraction of the macropores and  $Q_{ip}$  is the interporosity flow, which is the mass transfer from the macroscale to the microscale system. The indices **M** and **m** stand for macropores and micropores, respectively.

The feature has three default subfeatures—the **Fluid** subfeature where the fluid density  $\rho$  (SI unit: kg/m<sup>3</sup>) and dynamic viscosity  $\mu$  (SI unit: Pa·s) are defined, the **Macropores** subfeature where the hydraulic properties of the macroporous matrix are defined, and the **Micropores** where the hydraulic properties of the microporous matrix are defined.

### COORDINATE SYSTEM SELECTION

Select a coordinate system from the **Coordinate system** list for the interpretation of directions in anisotropic material properties. The default is the **Global coordinate system**, and the list contains any additional orthonormal coordinate system (except boundary coordinate systems) added under the **Definitions** node.

The subnodes inherit these coordinate system settings. In particular, the **Permeability** or **Hydraulic conductivity** (in the **Macropores** and **Micropores** subnodes) should be set according to the coordinate system selected in this section.

### STORAGE MODEL

With this option, define the first term in Equation 5-9. Therefore, choose from a list one of the following formulations:

- From retention model
- Linearized storage (default)
- From liquid content
- User defined

If **From retention model** is chosen, the first term of Equation 5-9 accounts only for the specific moisture capacity  $C_{m,i}$  which is defined by the **Retention Model** in the **Macropores** (i=M) or **Micropores** (i=m) subnode:

$$\frac{C_{m,i} \partial p}{g \partial t}.$$

For the option **Linearized storage** the storage coefficient  $S_{p,i}$  in Equation 5-9 is defined as

$$S_{p,i} = \varepsilon_{p,i} \chi_f + (1 - \varepsilon_{p,i}) \chi_{p,i}.$$

**From liquid content** enforces the first term of Equation 5-9 to be defined in terms of liquid volume fraction as

$$\frac{\partial(\rho \theta_{l,i})}{\partial t}$$

- and the **User defined** option allows to define the storage coefficient  $S_{p,i}$  in Equation 5-9 directly.



- [Storage Models](#) in the *Subsurface Flow Module User's Guide*
- 

### INTERPOROSITY FLOW

Specify the **Fluid Transfer Function**  $\alpha_w$  which is used to calculate the interporosity flow, which is the mass exchange between macro- and microscale system:

$$Q_{ip} = \alpha_w (p_M - p_m) \quad (5-10)$$

with  $p_M$  being the pressure within the macroscale system and  $p_m$  the pressure within the microscale system.



- [Dual Porosity & Dual Permeability Modeling](#) in the *Subsurface Flow Module User's Guide*
- 

### LOCATION IN USER INTERFACE

*Context Menus*

**Darcy's Law > Dual Porosity/Permeability > Unsaturated Dual Permeability Medium**

**Richards' Equation > Dual Porosity/Permeability > Unsaturated Dual Permeability Medium**

*Ribbon*

Physics tab with **Darcy's Law** or **Richards' Equation** selected:

**Domains > Dual Porosity/Permeability > Unsaturated Dual Permeability Medium**

*Macropores*

---

This node defines the porosity and material properties of the macroporous matrix of the [Dual Porosity Medium](#), the [Dual Permeability Medium](#), or the [Unsaturated Dual Permeability Medium](#) parent node.

**MODEL INPUT**

This section contains fields and values that are inputs for expressions defining material properties. If such user-defined property groups are added, the model inputs appear here.

**VOLUME FRACTION**

Here enter the **Volume Fraction of Macropores**,  $\theta_M$ .

**MATRIX PROPERTIES**

The default **Porosity**  $\epsilon_{p,M}$  of the solid matrix of the macropore system is taken **From material**. Select **User defined** to enter a value or expression for  $\epsilon_{p,M}$ .

If required by a **Storage model** in the parent node, specify the **Effective compressibility** of the porous matrix of the macropore system. The default value is  $\chi_{p,M} = 10^{-4}$  1/Pa.

Select a **Permeability model** to specify the capacity of the porous material to transmit flow. For the macropore settings only the Darcian Flow models are available. Select between the following options for the **Permeability model**:

- Select **Permeability** (default) to define the permeability of the porous matrix. The default **Permeability**  $\kappa_M$  (SI unit:  $m^2$ ) uses the value **From material**, as defined by the **Porous material**. For **User defined** select **Isotropic** to define a scalar value or **Diagonal** or **Symmetric** to define a tensor value.
- Select **Hydraulic conductivity** or define a combination of fluid permeability and dynamic viscosity. For **Hydraulic conductivity**  $K_M$  (SI unit: m/s) select **Isotropic** to

define a scalar value or **Diagonal** or **Symmetric** to define a tensor value. The default is  $2.94 \cdot 10^{-4}$  m/s.

- Select **Kozeny–Carman** to define the permeability from the porosity and mean particle diameter. Enter the mean **Particle diameter**  $d_{p,M}$  (SI unit: m), the default value is 0.5 mm.

### RETENTION MODEL

For an **Unsaturated Dual Permeability Medium** select between the following options for the retention model:

- **van Genuchten**, to specify the retention model using the van Genuchten relationship. Enter the constitutive relation constants  $\alpha$  (the default value is 1, and the SI unit is 1/m),  $n$  (default value is 2), and  $l$  (default value is 0.5). The constitutive parameter  $m$  is equal to  $1 - 1/n$ .
- **Brooks and Corey** to use the retention model according to the Brooks and Corey relationships.
- **User defined** to use a different retention model. Enter user defined expressions for the **Effective saturation**  $S_{e,M}$ , the **Liquid volume fraction**  $\theta_{l,M}$ . The default is  $\epsilon_{p,M}$  (the porosity variable). Specify the **Specific moisture capacity**  $C_{m,M}$  (SI unit: 1/m). The default value is 0 (1/m). Enter an expression for the **Relative permeability**  $\kappa_{r,M}$ . The default value is 1.

If there is a residual volume of liquid that cannot move through the pore network, also enter a value between 0 and 1 for the **Residual liquid volume fraction**  $\theta_r$ . The default value is 0.



[Retention and Permeability Relationships](#) in the *Subsurface Flow Module User's Guide*

---

### LOCATION IN USER INTERFACE

A default **Macropores** node is automatically added to the **Dual Porosity Medium**, the **Dual Permeability Medium**, and the **Unsaturated Dual Permeability Medium** node.

*Context Menus*

**Darcy's Law** > *porous medium feature* > **Macropores**

**Richards' Equation** > *porous medium feature* > **Macropores**

## *Micropores*

---

This node defines the porosity and material properties of the microporous matrix of the [Dual Porosity Medium](#), [Dual Permeability Medium](#), or the [Unsaturated Dual Permeability Medium](#) parent node.

### **MODEL INPUT**

This section is only available for the [Unsaturated Dual Permeability Medium](#) parent node and contains fields and values that are inputs for expressions defining material properties. If such user-defined property groups are added, the model inputs appear here.

### **MATRIX PROPERTIES**

The default **Porosity**  $\varepsilon_{p,m}$  of the solid matrix of the micropore system is taken **From material**. Select **User defined** to enter a value or expression for  $\varepsilon_{p,m}$ .

If required by a **Storage model** in the parent node, specify the **Effective compressibility** of the microscale porous matrix. The default value is  $\chi_{p,m} = 10^{-4}$  1/Pa.

Select a **Permeability model** to specify the capacity to transmit flow for the porous material of the microscale system. Here, only the Darcian Flow models are available.

Select between the following options for the **Permeability model**:

- Select **Permeability** (default) to define the permeability of the porous matrix. The default **Permeability**  $\kappa_m$  (SI unit:  $m^2$ ) uses the value **From material**, as defined by the **Porous material**. For **User defined** select **Isotropic** to define a scalar value or **Diagonal** or **Symmetric** to define a tensor value.
- Select **Hydraulic conductivity** or define a combination of fluid permeability and dynamic viscosity. For **Hydraulic conductivity**  $K_m$  (SI unit: m/s) select **Isotropic** to define a scalar value or **Diagonal** or **Symmetric** to define a tensor value. The default is  $2.94 \cdot 10^{-4}$  m/s.
- Select **Kozeny–Carman** to define the permeability from the porosity and mean particle diameter. Enter the mean **Particle diameter**  $d_{p,m}$  (SI unit: m), the default value is 0.5 mm.

### **RETENTION MODEL**

For an [Unsaturated Dual Permeability Medium](#) select between the following options for the retention model:

- **From macropores** to take over the retention model settings from the **Macropores** node.

- **van Genuchten**, to specify the retention model using the van Genuchten relationship. Enter the constitutive relation constants  $\alpha$  (the default value is 1, and the SI unit is 1/m),  $n$  (default value is 2), and  $l$  (default value is 0.5). The constitutive parameter  $m$  is equal to  $1 - 1/n$ .
- **Brooks and Corey** to use the retention model according to the Brooks and Corey relationships.
- **User defined** to use a different retention model. Enter user defined expressions for the **Effective saturation**  $S_{e,m}$ , the **Liquid volume fraction**  $\theta_{l,m}$ . The default is  $\epsilon_{p,m}$  (the porosity variable). Specify the **Specific moisture capacity**  $C_{m,m}$  (SI unit: 1/m). The default value is 0 (1/m). Enter an expression for the **Relative permeability**  $\kappa_{r,m}$ . The default value is 1.

If there is a residual volume of liquid that cannot move through the pore network, also enter a value between 0 and 1 for the **Residual liquid volume fraction**  $\theta_r$ . The default value is 0.



Retention and Permeability Relationships in the *Subsurface Flow Module*  
*User's Guide*

### INITIAL VALUES

Define the initial pressure of the microscale system. The default is to use the initial values defined in the [Initial Values](#) feature node which means that the same initial values apply to the macroscale and the microscale system.

Select **User Defined** to specify an initial pressure for the microscale system  $p_{m0,init}$ .



Note that some options are only available in some modules. For a detailed overview of the functionality available in each product, visit [www.comsol.com/products/specifications/](http://www.comsol.com/products/specifications/)

### LOCATION IN USER INTERFACE

A default **Micropores** node is automatically added to the [Dual Porosity Medium](#), the [Dual Permeability Medium](#), and the [Unsaturated Dual Permeability Medium](#) node.

*Context Menus*

**Darcy's Law** > *porous medium feature* > **Micropores**

**Richards' Equation** > *porous medium feature* > **Micropores**

## Mass Source

---

The **Mass Source** node adds a mass source  $Q_m$ , which appears on the right-hand side of the Darcy's Law equation (Equation 5-3).

$$\frac{\partial}{\partial t}(\rho\varepsilon) + \nabla \cdot (\rho\mathbf{u}) = Q_m \quad (5-11)$$

For the Fracture Flow interface, the mass source is applicable to the right-hand side of Equation 4-40 in the *Subsurface Flow Module User's Guide* (where it is multiplied with the fracture thickness).

### MASS SOURCE

Enter a value or expression for the **Mass source**  $Q_m$  (SI unit: kg/(m<sup>3</sup>·s)). The default is 0 kg/(m<sup>3</sup>·s).

### LOCATION IN USER INTERFACE

#### Context Menus

**Darcy's Law > Mass Source**

**Richards' Equation > Mass Source**

#### Ribbon

Physics tab with *interface* as **Darcy's Law** or **Richards' Equation** selected:

**Domains > interface > Mass Source**

## Contributing Velocity

---

The **Contributing Velocity** node adds a velocity contribution  $\mathbf{u}_{\text{ctrb}}$  to the velocity field  $\mathbf{u}_d$  that is computed from the flow model selected in the parent **Porous Medium**, **Unsaturated Porous Medium**, or **Dual Porosity Medium** feature. The total velocity field used in the continuity equation is therefore

$$\mathbf{u} = \mathbf{u}_d + \mathbf{u}_{\text{ctrb}} \quad (5-12)$$

Such velocity contributions can arise in multiphysics models that involve, for example, transport of solutes. If several **Contributing Velocity** nodes are added under the same parent feature, the contributions are treated additively. The sum of all contributing velocity fields is available in the variables `name.Uctrb` (material frame) and `name.uctrb` (spatial frame), with `name` being the **Name** of the physics interface (for example, `d1`).

## COORDINATE SYSTEM SELECTION

Select a coordinate system from the **Coordinate system** list to specify the coordinate system in which the contributing velocity field is given. The default is the **Global coordinate system**. Note that the coordinate system used to specify the components of the contributing velocity field can be selected independently of the coordinate system of the parent feature.

## CONTRIBUTING VELOCITY

The default contributing velocity field  $\mathbf{u}_{\text{ctrb}}$  is **User defined**, which lets you enter the components of the contributing velocity field explicitly. If a matching velocity field is announced by another feature, it will be available in the selection list.

## ADVANCED

Select the **Frame** in which the contributing velocity field is specified. The default is the **Reference configuration**, which means that the velocity field follows the material under, for example, a rotation of the domain. If instead your contributing velocity field follows a fixed direction in space, select the **Deformed configuration**. This section is only displayed if **Advanced Physics Options** is activated and the spatial and material frame of the component differ, such as in the presence of a **Moving Mesh** or **Solid Mechanics** interface.

## LOCATION IN USER INTERFACE

### *Context Menus*

If the selected *porous medium feature* is [Porous Medium](#), [Unsaturated Porous Medium](#), or [Dual Porosity Medium](#):

**Darcy's Law** > *porous medium feature* > **Contributing Velocity**

**Richards' Equation** > *porous medium feature* > **Contributing Velocity**

### *Ribbon*

Physics tab with **Porous Medium**, **Unsaturated Porous Medium**, or **Dual Porosity Medium** selected:

**Attributes** > **Contributing Velocity**

### *Initial Values*

---

The **Initial Values** node adds an initial value for the pressure that can serve as an initial condition for a transient simulation or as an initial guess for a nonlinear solver.

If you have the Subsurface Flow Module licensed, you can specify the pressure either directly or as an expression for the pressure head,  $H_p$ , or the hydraulic head,  $H$ ; the hydraulic head and the pressure head relate to the pressure  $p$  as

$$H_p = \frac{p}{\rho g}; \quad H = H_p + D$$

where  $\rho$  is the fluid density (SI unit:  $\text{kg}/\text{m}^3$ );  $g$  denotes the acceleration of gravity (SI unit:  $\text{m}/\text{s}^2$ ); and  $D$  is the elevation (SI unit: m).

### INITIAL VALUES

Enter a value or expression for the initial value of the **Pressure**  $p$  (SI unit: Pa). The default value is 0 Pa.

In case the Subsurface Flow Module is available, click the **Pressure head** button to enter a value or expression for  $H_p$  (SI unit: m). The default is 0 m. Click the **Hydraulic head** button to enter a value or expression for  $H$  (SI unit: m). The default is 0 m.

### LOCATION IN USER INTERFACE

*Context Menus*

**Darcy's Law** > **Initial Values**

**Richards' Equation** > **Initial Values**

*Ribbon*

Physics tab with *interface* as **Darcy's Law** or **Richards' Equation** selected:

**Domains** > *interface* > **Initial Values**

*Gravity*

---

The **Gravity** node is automatically added when **Include gravity** is selected at interface level in the **Darcy's Law** settings and it is active in all domains in which the Darcy's Law interface is applied.

### COORDINATE SYSTEM SELECTION

The **Global coordinate system** is selected by default. The **Coordinate system** list contains any additional coordinate systems that the model includes. It can be used when prescribing the direction of the gravitational forces.

## GRAVITY

Specify either the acceleration vector or — in case you have a Subsurface Flow Module license — the elevation.

When **Acceleration** is selected from the list, enter the components of the **Gravity vector  $\mathbf{g}$** . The default value is `g_const` which is the physical constant having the value  $9.8066 \text{ m/s}^2$ .

- For 3D and 2D axisymmetric models, the default value is `-g_const` in the  $z$  direction.
- For 2D models, the default value is `-g_const` in the  $y$  direction.

When **Elevation** is selected from the list, specify the **Elevation  $D$**  (SI unit: m). The **Acceleration of gravity** is taken **From physics interface** by default but could be overridden when **User defined** is selected.

When the checkbox **Include gravity** is not selected in the Darcy's Law interface Settings, the elevation  $D$  is set equal to zero.

Select the checkbox **Specify reference position** to define a reference position for the gravity calculation.

## LOCATION IN USER INTERFACE

*Context Menus*

**Darcy's Law > Gravity**

**Richards' Equation > Gravity**

*Cross Section*

---

Use this node with 1D components to model domains with another cross-sectional area than the global one that is used in the interface **Physical Model** section. In 1D geometries, the pressure is assumed to be constant in the radial direction, and Darcy's Law accounts for that.

## CROSS SECTION

Enter values for the **Cross-sectional area  $A_c$**  to set the cross section of the domain in the plane perpendicular to the 1D geometry.

## LOCATION IN USER INTERFACE

*Context Menus*

**Darcy's Law** > **Cross Section**

**Richards' Equation** > **Cross Section**

*Ribbon*

Physics tab with *interface* as **Darcy's Law** or **Richards' Equation** selected:

**Domains** > *interface* > **Cross Section**

*Thickness*

---

Use this node with 2D and 1D axisymmetric components to model domains with another thickness than the overall thickness that is specified in the interface **Physical Model** section. In 2D geometries, the pressure is assumed to be constant in the out-of-plane direction (the  $z$  direction with default spatial coordinate names). In 1D axisymmetric geometries the thickness represents the  $z$  direction.

### THICKNESS

Specify a value for the **Thickness**  $d_z$  of the domain in the out-of-plane direction. This value replaces the overall thickness in the domains that are selected in the **Domain Selection** section, and is used to multiply some terms into the heat equation.

## LOCATION IN USER INTERFACE

*Context Menus*

**Darcy's Law** > **Thickness**

**Richards' Equation** > **Thickness**

*Ribbon*

Physics tab with *interface* as **Darcy's Law** or **Richards' Equation** selected:

**Domains** > *interface* > **Thickness**

*Porous Electrode Coupling*

---

Use the **Porous Electrode Coupling** node to define a mass source based on the volumetric current densities of one or multiple **Porous Electrode Reaction** nodes in an Electrochemistry interface.

The source (or sink) is proportional to the **Molar mass (kg/mol)** of the reacting species, the current densities and the stoichiometric coefficients according to Faraday's law as defined by summation over the Reaction Coefficient subnodes.

### SPECIES

Based on the number of species required for the model, use the **Add ( + )** and **Delete (≡x)** buttons under the table to add or remove **Species**. Then enter a value for the **Molar mass (kg/mol)** in the applicable rows for each species.

The setting in the table will determine the number of available fields for entering the stoichiometric coefficients of the Reaction Coefficient subnodes.

### LOCATION IN USER INTERFACE

*Context Menus*

**Darcy's Law > Porous Electrode Coupling**

**Richards' Equation > Porous Electrode Coupling**

*Ribbon*

Physics tab with *interface* as **Darcy's Law** or **Richards' Equation** selected:

**Domains > interface > Porous Electrode Coupling**

### *Electrode Surface Coupling*

---

Use the **Electrode Surface Coupling** node to define a combined wall and inflow/outflow boundary condition based on current densities of one or multiple Electrode Reaction nodes in an Electrochemistry interface.

The flow is proportional to the **Molar mass (kg/mol)** of the reacting species, the current densities and the stoichiometric coefficients according to Faraday's law as defined by summation over the Reaction Coefficient subnodes.

### SPECIES

Based on the number of species required for the model, use the **Add ( + )** and **Delete (≡x)** buttons under the table to add or remove **Species**. Then enter a value for the **Molar mass (kg/mol)** in the applicable rows for each species.

The setting in the table will determine the number of available field for entering the stoichiometric coefficients of the Reaction Coefficient subnodes.

## LOCATION IN USER INTERFACE

*Context Menus*

**Darcy's Law** > **Electrode Surface Coupling**

**Richards' Equation** > **Electrode Surface Coupling**

*Ribbon*

Physics tab with *interface* as **Darcy's Law** or **Richards' Equation** selected:

**Boundaries** > *interface* > **Electrode Surface Coupling**

*Pressure*

---

Use the **Pressure** node to specify the pressure on a boundary. In many cases the distribution of pressure is known, giving a Dirichlet condition  $p = p_0$  where  $p_0$  is a known pressure given as a number, a distribution, or an expression involving time,  $t$ , for example.

### PAIR SELECTION

If this node is selected from the **Pairs** menu, choose the pair to apply this condition to. A pair must be created first. See [Identity, Contact, and Sector Symmetry Pairs](#) in the *COMSOL Multiphysics Reference Manual* for more details.

### PRESSURE

Enter a value or expression for the **Pressure**  $p_0$  (SI unit: Pa). Enter a relative pressure value in  $p_0$  (SI unit: Pa).

For the Subsurface Flow Module, the **Pressure** node provides the pressure  $P_0$  as a condition on edges in 3D models. Then select the edges under **Edge Selection**.

### CONSTRAINT SETTINGS

To display this section, click the **Show More Options** button (  ) and select **Advanced Physics Options** in the **Show More Options** dialog.

As an attribute to the [Fracture](#) boundary condition or as boundary condition to [The Fracture Flow Interface](#) (which are available in the Subsurface Flow Module and the Porous Media Flow Module), the pressure can also be specified on edges (in 3D) or

points (in 2D) surrounding the fracture domain. In other cases, pressure constraints on edges or points are not implemented.



If the boundary condition is adjacent to an [Unsaturated Dual Permeability Medium](#) feature it constrains the pressures in the [Macropores](#) and [Micropores](#) to  $p_0$ .

## LOCATION IN USER INTERFACE

*Context Menus*

**Darcy's Law > Pressure**

**Richards' Equation > Pressure**

*Ribbon*

Physics tab with *interface* as **Darcy's Law** or **Richards' Equation** selected:

**Boundaries > interface > Pressure**

**Pairs > interface > Pressure**

## *Mass Flux*

Use the **Mass Flux** node to specify the mass flux into or out of the model domain through some of its boundaries. It is often possible to determine the mass flux from the pumping rate or from measurements. With this boundary condition, positive values correspond to flow into the model domain:

$$\mathbf{n} \cdot \rho \frac{k}{\mu} (\nabla p + \rho g \nabla D) = N_0$$

where  $N_0$  is a value or expression for the specified inward (or outward) Darcy flux.  $D$  is the elevation head which is set to zero for other than Subsurface Flow Module applications.

## **MASS FLUX**

Enter a value or expression for the **Inward mass flux**  $N_0$ . A positive value of  $N_0$  represents an inward mass flux whereas a negative value represents an outward mass flux. The units are based on the geometric entity: **Boundaries**: (SI unit:  $\text{kg}/(\text{m}^2 \cdot \text{s})$ ).

## LOCATION IN USER INTERFACE

### *Context Menus*

**Darcy's Law > Mass Flux**

**Richards' Equation > Mass Flux**

### *Ribbon*

Physics tab with *interface* as **Darcy's Law** or **Richards' Equation** selected:

**Boundaries > interface > Mass Flux**

### *Line Mass Source*

---

The **Line Mass Source** node adds mass flow originating from a tube of infinitely small radius.

## SELECTION

The **Line Mass Source** feature is available for all dimensions, but the applicable selection differs between the dimensions.

MODEL DIMENSION	APPLICABLE GEOMETRICAL ENTITY
2D	Points
2D Axisymmetry	Points not on the symmetry axis
3D	Edges

## LINE MASS SOURCE

Enter a value or expression for the source strength,  $N_0$  (SI unit: kg/(m·s)). A positive value results in mass injection from the line into the computational domain, and a negative value means that the mass is removed from the computational domain.

Line sources located on a boundary affect the adjacent computational domains. This effect makes the physical strength of a line source located in a symmetry plane twice the given strength.

### *Fracture Flow*

The equivalent feature available for fracture flow is the **Mass Source** attribute of the [Fracture](#) boundary condition and the **Mass Source** point feature of the Fracture Flow Interface, both available in 3D only.

## LOCATION IN USER INTERFACE

According to the model dimension as mentioned in [Selection](#), this feature is available for the *geometrical entities* **Edges** or **Points**.

*Context Menus*

**Darcy's Law** > *geometrical entity* > **Line Mass Source**

**Richards' Equation** > *geometrical entity* > **Line Mass Source**

*Ribbon*

Physics tab with **Darcy's Law** or **Richards' Equation** selected:

*geometrical entity* > **Line Mass Source**

## *Point Mass Source*

---

The **Point Mass Source** node models mass flow originating from an infinitely small sphere centered around a point. It is available for points in 3D geometries.

## POINT MASS SOURCE

Enter a value or expression for the source strength,  $N_0$  (SI unit: kg/(s)). A positive value results in mass injection from the point into the computational domain, and a negative value means that the mass is removed from the computational domain.

Point sources located on a boundary or on an edge affect the adjacent computational domains. This has the effect, for example, that the physical strength of a point source located in a symmetry plane is twice the given strength.

## LOCATION IN USER INTERFACE

*Context Menus*

**Darcy's Law** > **Points** > **Point Mass Source**

**Richards' Equation** > **Points** > **Point Mass Source**

*Ribbon*

Physics tab with **Darcy's Law** or **Richards' Equation** selected:

**Points** > **Point Mass Source**

## *Inlet*

---

The **Inlet** node adds a boundary condition for the inflow (or outflow) perpendicular (normal) to the boundary. It has three options that can be used to specify inlet condition on a boundary, as follows:

### **VELOCITY**

Enter a value or expression for the **Normal inflow velocity**  $U_0$  (SI unit: m/s). A positive value of  $U_0$  represents an inflow velocity. A negative value represents an outflow velocity. The inlet velocity boundary condition is implemented as;

$$\mathbf{n} \cdot \rho \frac{\kappa}{\mu} (\nabla p + \rho \mathbf{g} \nabla D) = \rho U_0$$

where  $U_0$  is a value or expression for the specified inward (or outward) Darcy velocity. A positive value of the velocity  $U_0$  corresponds to flow into the model domain whereas a negative value represents an outflow.  $D$  is the elevation head which is set to zero for other than Subsurface Flow Module applications.

### **PRESSURE**

Use the **Pressure** option to specify the inlet pressure on a boundary. In many cases the distribution of pressure is known, giving a Dirichlet condition  $p = p_0$  where  $p_0$  is a known pressure given as a number, a distribution, or an expression involving time,  $t$ , for example. Enter a value or expression for the **Pressure**  $p_0$  (SI unit: Pa).

### **MASS FLOW**

If you select **Mass flow** as the inlet condition, there are four options to specify the **Mass flow type**: the total **Mass flow rate**  $M_0$  (SI unit: kg/s), the **Pointwise mass flux**  $N_0$  (kg/(m<sup>2</sup>·s)), the **Standard flow rate**  $Q_{sv}$  (m<sup>3</sup>/s), and the **Standard flow rate**  $Q_{scem}$  (in number of SCCM units).

With the options **Mass flow rate**, **Standard flow rate**, and **Standard flow rate SCCM**, positive values correspond to flow into the model domain:

$$-\int_{\partial\Omega} \rho(\mathbf{u} \cdot \mathbf{n}) dS = M_0$$

where  $M_0$  is a value or expression for the specified inward (or outward) Darcy flux.

For the **Standard flow rate**  $Q_{sv}$ , which is a volumetric flow rate of a gas at standard density according to the SEMI standard E12-0303, the equation above is divided by the standard density term:

$$-\int_{\partial\Omega} \frac{\rho}{\rho_{std}} (\mathbf{u} \cdot \mathbf{n}) dS = Q_{sv}$$

$\rho_{std}$  can be specified as mean molar mass  $m_m$  divided by a standard molar volume  $V_m$ , or as a function of standard pressure  $p_{st}$  and standard temperature  $T_{st}$ :

$$\rho_{std} = \frac{p_{st} m_m}{RT_{st}}$$

The **Standard flow rate SCCM** option is equivalent to the Standard flow rate option, except that the flow rate is entered directly in SCCMs (standard cubic centimeters per minute) without the requirement to specify units. Here, the dimensionless number of SCCM units  $Q_{sccm}$  should be specified.

In the **Pointwise mass flux** boundary condition, positive values correspond to flow into the model domain:

$$\mathbf{n} \cdot \rho \frac{\kappa}{\mu} (\nabla p + \rho g \nabla D) = N_0$$

where  $N_0$  is a value or expression for the specified inward (or outward) Darcy flux.

## CONSTRAINT SETTINGS

To display this section, click the **Show More Options** button (  ) and select **Advanced Physics Options** in the **Show More Options** dialog.

## LOCATION IN USER INTERFACE

*Context Menus*

**Darcy's Law** > Inlet

**Richards' Equation** > Inlet

*Ribbon*

Physics tab with *interface* as **Darcy's Law** or **Richards' Equation** selected:

**Boundaries** > *interface* > Inlet

## Symmetry

---

The **Symmetry** node describes a symmetry boundary. The following condition implements the symmetry condition on an axis or a flow divide:

$$\mathbf{n} \cdot \frac{\kappa}{\mu} \nabla p = 0$$

$$\mathbf{n} \cdot \frac{\kappa}{\mu} (\nabla p + \rho g \nabla D) = 0$$

For axisymmetric components, COMSOL Multiphysics takes the axial symmetry boundaries (at  $r = 0$ ) into account and automatically adds an **Axial Symmetry** node that is valid on the axial symmetry boundaries only.

### LOCATION IN USER INTERFACE

*Context Menus*

**Darcy's Law > Symmetry**

**Richards' Equation > Symmetry**

*Ribbon*

Physics tab with *interface* as **Darcy's Law** or **Richards' Equation** selected:

**Boundaries > interface > Symmetry**

## No Flow

---

The **No Flow** node is the default boundary condition stating that there is no flow across impermeable boundaries. The mathematical formulation is:

$$\mathbf{n} \cdot \rho \frac{\kappa}{\mu} (\nabla p + \rho g \nabla D) = 0$$

where  $\mathbf{n}$  is the vector normal to the boundary.  $D$  is the elevation head which is set to zero for any other than Subsurface Flow Module applications.

### LOCATION IN USER INTERFACE

*Context Menus*

**Darcy's Law > No Flow**

**Richards' Equation > No Flow**

*Ribbon*

Physics tab with *interface* as **Darcy's Law** or **Richards' Equation** selected:

**Boundaries > interface > No Flow**

### *Flux Discontinuity*

---

Use the **Flux Discontinuity** node to specify a mass flux discontinuity through an interior boundary. The condition is represented by the following equation:

$$-\mathbf{n} \cdot (\rho \mathbf{u}_1 - \rho \mathbf{u}_2) = N_0$$

In this equation,  $\mathbf{n}$  is the vector normal (perpendicular) to the interior boundary,  $\rho$  is the fluid density,  $\mathbf{u}_1$  and  $\mathbf{u}_2$  are the Darcy velocities in the adjacent domains (as defined in Equation 5-13) and  $N_0$  is a specified value or expression for the flux discontinuity.

$$\mathbf{u} = -\frac{\kappa}{\mu} \nabla p \quad (5-13)$$

For this boundary condition, a positive value of  $N_0$  corresponds to a flow discontinuity in the opposite direction to the normal vector of the interior boundary.

#### **MASS FLUX**

Enter a value or expression for the **Inward mass flux**  $N_0$  (SI unit: kg/(m<sup>2</sup>·s)). A positive value of  $N_0$  represents a mass flux discontinuity in the opposite direction to the normal vector of the interior boundary.

#### **LOCATION IN USER INTERFACE**

*Context Menus*

**Darcy's Law > Thin Structures > Flux Discontinuity**

**Richards' Equation > Thin Structures > Flux Discontinuity**

*Ribbon*

Physics tab with **Darcy's Law** or **Richards' Equation** selected:

**Boundaries > Thin Structures > Flux Discontinuity**

**Pairs > Flux Discontinuity**

## Outlet

---

The **Outlet** node adds a boundary condition for the outflow (or inflow) perpendicular (normal) to the boundary. It has different options that can be used to specify inlet condition on a boundary, as follows:

### VELOCITY

Enter a value or expression for the **Normal outflow velocity**  $U_0$  (SI unit: m/s). A positive value of  $U_0$  represents an outflow velocity whereas a negative value represents an inflow velocity.

$$-\mathbf{n} \cdot \rho \frac{\kappa}{\mu} \nabla p = \rho U_0$$

where  $U_0$  is a specified value or expression for the outward (or inward) Darcy velocity.

### PRESSURE

Similar to the inlet **Pressure** option, the outlet pressure on a boundary can be specified. Enter a value or expression for the **Pressure**  $p_0$  (SI unit: Pa).

### DISCHARGE

Enter a value or expression for the discharge  $Q_D$  to specify the volumetric flow rate through the boundary. The mass flux  $\rho \mathbf{u}$  is related to the discharge as follows:

$$\int_{\partial\Omega} \rho \mathbf{u} \cdot \mathbf{ds} = \rho Q_D. \quad (5-14)$$

The mean normal outflow velocity at the boundary can then be calculated as  $U_{\text{out}} = Q_D/A$ , where  $A$  is the cross-sectional area of the boundary.

### LOCATION IN USER INTERFACE

*Context Menus*

**Darcy's Law > Outlet**

**Richards' Equation > Outlet**

*Ribbon*

Physics tab with *interface* as **Darcy's Law** or **Richards' Equation** selected:

**Boundaries > interface > Outlet**

## *Precipitation*

---

The **Precipitation** node adds a boundary condition for the inflow (of rain) perpendicular (normal) to the boundary.

Enter a value or expression for the **Precipitation rate** which then contributes to the mass flux at the selected boundaries.

Select the **Slope correction** checkbox to apply a correction that depends on the normal to the boundary and the vertical axis. This is needed when the boundary is inclined.

### **LOCATION IN USER INTERFACE**

#### *Context Menus*

**Darcy's Law > Hydraulics > Precipitation**

**Richards' Equation > Hydraulics > Precipitation**

#### *Ribbon*

Physics tab with **Darcy's Law** or **Richards' Equation** selected:

**Boundaries > Hydraulics > Precipitation**

## *Periodic Condition*

---

Use this node to add a periodic condition to at least two boundaries (source and destination boundaries). It applies a pressure condition as follows:

$$p_{\text{src}} = p_{\text{dst}} + \Delta p$$

### **FLOW CONDITION**

Specify either a **Pressure difference**  $\Delta p$  or a **Mass flow**  $\dot{m}$ . If the mass flow option is selected, the pressure difference is computed such that

$$\dot{m} = \int_{\text{dst}} \rho \mathbf{u} \cdot \mathbf{n}$$

## BOUNDARY SELECTION AND ORIENTATION

---



The software usually automatically identifies the boundaries as either source or destination boundaries, as indicated in the selection list. This works fine for cases like opposing parallel boundaries. In other cases, right-click **Periodic Flow Condition** and select **Manual Destination Selection** to control the destination.

More details on how to handle curved boundaries and mapping between source and destination are located in the [Periodic Boundary Conditions](#) section in the *Comsol Multiphysics Reference Manual*.

---

### *Interior Wall*

---

The **Interior Wall** boundary condition can only be applied on interior boundaries. It is similar to the **No Flux** boundary available on exterior boundaries except that it applies on both sides of an interior boundary. It allows discontinuities of velocity and pressure across the boundary. The **Interior Wall** boundary condition can be used to avoid meshing thin structures by applying no-flux condition on interior curves and surfaces instead.

### LOCATION IN USER INTERFACE

#### *Context Menus*

**Darcy's Law > Thin Structures > Interior Wall**

**Richards' Equation > Thin Structures > Interior Wall**

#### *Ribbon*

Physics tab with **Darcy's Law** or **Richards' Equation** selected:

**Boundaries > Thin Structures > Interior Wall**

### *Barrier*

---

The **Barrier** boundary condition models interior permeable walls, membranes, geotextiles, or perforated plates as thin permeable barriers. The **Barrier** boundary condition can only be applied on interior boundaries.

## WALL

Enter a value or expression for the **Thickness**  $d_b$  (SI unit: m, the default is 0.1 m) and for the **Permeability**  $\kappa_b$  (SI unit:  $m^2$ ). The default **Permeability**  $\kappa_b$  uses the value **From material**. For **User defined** select **Isotropic** to define a scalar value or **Diagonal**, **Symmetric**, or **Full** to define a tensor value and enter another value or expression in the field or matrix.

## LOCATION IN USER INTERFACE

### *Context Menus*

**Darcy's Law** > **Thin Structures** > **Barrier**

**Richards' Equation** > **Thin Structures** > **Barrier**

### *Ribbon*

Physics tab with **Darcy's Law** or **Richards' Equation** selected:

**Boundaries** > **Thin Structures** > **Barrier**

### *Pressure Head*

---

Use the **Pressure Head** node to specify the pressure head (instead of the pressure) on a boundary. It adds this boundary condition for the pressure head  $H_p = H_{p0}$ , where  $H_{p0}$  is a known pressure head given as a number, a distribution, or an expression involving time,  $t$ , for example. The dimension of the pressure head is length (SI unit: m).

## PRESSURE HEAD

Enter a value or expression for the **Pressure head**  $H_{p0}$  (SI unit: m). The default is 0 m.

## CONSTRAINT SETTINGS

To display this section, click the **Show More Options** button (  ) and select **Advanced Physics Options** in the **Show More Options** dialog.

## LOCATION IN USER INTERFACE

### *Context Menus*

**Darcy's Law** > **Hydraulics** > **Pressure Head**

**Richards' Equation** > **Hydraulics** > **Pressure Head**

### *Ribbon*

Physics tab with **Darcy's Law** or **Richards' Equation** selected:

**Boundaries** > **Hydraulics** > **Pressure Head**

## Pairs > Pressure Head

### *Hydraulic Head*

---

Use the **Hydraulic Head** node to specify the hydraulic head (instead of the pressure) on a boundary. This adds the Dirichlet condition for the hydraulic head  $H = H_0$  where  $H_0$  is a known hydraulic head given as a number, a distribution, or an expression involving time,  $t$ , for example.

#### HYDRAULIC HEAD

Enter a value or expression for the **Hydraulic head**  $H_0$  (SI unit: m). The default is 0 m.

#### CONSTRAINT SETTINGS

To display this section, click the **Show More Options** button (  ) and select **Advanced Physics Options** in the **Show More Options** dialog.

#### LOCATION IN USER INTERFACE

##### *Context Menus*

**Darcy's Law > Hydraulics > Hydraulic Head**

**Richards' Equation > Hydraulics > Hydraulic Head**

##### *Ribbon*

Physics tab with **Darcy's Law** or **Richards' Equation** selected:

**Boundaries > Hydraulics > Hydraulic Head**

**Pairs > Hydraulic Head**

### *Atmosphere/Gauge*

---

The **Atmosphere/Gauge** node specifies an atmospheric pressure or gauges the pressure to the atmospheric value. This means that the total hydraulic potential reduces to the gravitational pressure at the free surface. At a free surface, such as a spring or a seepage face, the pressure is atmospheric. If the pressures in the model is gauged to the atmospheric value ( $p = 0$ ), the total hydraulic potential reduces to the gravitational potential at the free surface — for example, the height of the free surface multiplied by the fluid weight, or  $\rho_f g D$ . This boundary condition sets the pressure at the boundary to zero and  $p = 0$ .

## CONSTRAINT SETTINGS

To display this section, click the **Show More Options** button (  ) and select **Advanced Physics Options** in the **Show More Options** dialog.

## LOCATION IN USER INTERFACE

*Context Menus*

**Darcy's Law > Hydraulics > Atmosphere/Gauge**

**Richards' Equation > Hydraulics > Atmosphere/Gauge**

*Ribbon*

Physics tab with **Darcy's Law** or **Richards' Equation** selected:

**Boundaries > Hydraulics > Atmosphere/Gauge**

*Pervious Layer*

---

The **Pervious Layer** node provides a boundary condition that describes a mass flux through a semi-pervious layer connected to an external fluid source at different pressure, pressure head, or hydraulic head. The model domain might connect to a larger body of water through the semi-pervious layer. This condition is represented with the following boundary condition:

$$\mathbf{n} \cdot \rho \frac{\kappa}{\mu} (\nabla p + \rho g \nabla D) = \rho R_b \left[ \frac{(p_b - p)}{\rho g} + (D_b - D) \right] \quad (5-15)$$

In this equation,  $p_b$  (SI unit: Pa) and  $D_b$  (SI unit: m) are the pressure and the elevation of the distant fluid source, respectively, and  $R_b$  (SI unit: 1/s) is the conductance of materials between the source and the model domain (conductance to flow in the semi-pervious layer adjacent to the boundary). Typically  $R_b = K'/B'$ , where  $K'$  is the hydraulic conductivity (SI unit: m/s) of the layer and  $B'$  (SI unit: m) is its thickness. Using logical relationships, it is possible to activate these expressions at different times or under various flow conditions.

When the pressure head  $H_p$  is specified instead of the pressure, the boundary condition is the following:

$$\mathbf{n} \cdot \rho K \nabla (H_p + D) = \rho R_b [(H_{pb} - H_p) + (D_b - D)] \quad (5-16)$$

$H_{pb}$  is the pressure head (SI unit: m) at the edge of the layer.

When the hydraulic head  $H$  is specified instead of the pressure head, the boundary condition becomes:

$$\mathbf{n} \cdot \rho K \nabla H = \rho R_b [H_b - H] \quad (5-17)$$

$H_b$  is the hydraulic head (SI unit: m) at the edge of the layer.

$K$  in Equation 5-16 and Equation 5-17 is the hydraulic conductivity.

At a free surface, such as a water table or seepage face, the pressure is atmospheric (here taken to be zero), so the total hydraulic potential equals gravitational potential, which is defined on  $D$ .



Gravity effects are not active by default. Select the checkbox **Include gravity** to activate the acceleration of gravity. Setting the elevation  $D$  to zero also turns off gravity effects.

#### PERVIOUS LAYER

Specify the material properties whether to specify an external pressure, pressure head, or hydraulic head.

Select an **External variable to specify** — **Pressure and elevation** to specify the external pressure, **Pressure head and elevation** to specify the external pressure head, or **Hydraulic head**. For all selections, enter a value for the **Conductance  $R_b$**  (SI unit: 1/s).

- For **Pressure and elevation** enter an **External pressure  $p_b$**  (SI unit: Pa) and **External elevation  $D_b$**  (SI unit: m).
- For **Pressure head and elevation** enter an **External pressure head  $H_{pb}$**  (SI unit: m),  $H_{pb}$  (SI unit: m) and **External elevation  $D_b$**  (SI unit: m).
- For **Hydraulic head** enter the **Hydraulic head  $H_b$**  (SI unit: m).

#### LOCATION IN USER INTERFACE

*Context Menus*

**Darcy's Law > Hydraulics > Pervious Layer**

**Richards' Equation > Hydraulics > Pervious Layer**

*Ribbon*

Physics tab with **Darcy's Law** or **Richards' Equation** selected:

**Boundaries > Hydraulics > Pervious Layer**

## Well

---

The **Well** feature is intended to model injection or production wells and is available with the Subsurface Flow Module.

### WELL

Enter a value or expression for the **Well diameter**  $d_w$  (SI unit: m, the default is 0.1 m). Select the **Well type** from the list: **Production** or **Injection**.

Specify either the **Pressure** (SI unit: Pa), **Pressure head** (SI unit: m), **Hydraulic head** (SI unit: m), or the **Mass flow**. If you select **Mass flow**, specify the total **Mass flow rate** (SI unit: kg/s), the **Mass flow rate per unit length** (SI unit: kg/(m·s)) or the **Mass flux** (SI unit: kg/(m<sup>2</sup>·s)).

### LOCATION IN USER INTERFACE

According to the model dimension this feature is available for the *geometrical entities* **Edges** (3D) or **Points** (2D).

*Context Menus*

**Darcy's Law** > *geometrical entity* > **Well**

**Richards' Equation** > *geometrical entity* > **Well**

*Ribbon*

Physics tab with **Darcy's Law** or **Richards' Equation** selected:

*geometrical entity* > **Well**

## Fracture

---

Use the **Fracture** node to model flow along a boundaries representing fractures within a porous medium. By default, it adds the tangential form of the continuity equation and of Darcy's Law.

$$d_f \frac{\partial}{\partial t} (\epsilon_p \rho) + \nabla_T \cdot (d_f \rho \mathbf{u}) = d_f Q_m \quad (5-18)$$

$$\mathbf{u} = -\frac{\kappa}{\mu} \nabla_T p \quad (5-19)$$

The **Fracture** feature has two default subfeatures — the **Fluid (Fracture)** subfeature where the fluid density  $\rho$  (SI unit: kg/m<sup>3</sup>) and dynamic viscosity  $\mu$  (SI unit: Pa·s) are

defined and the [Fracture Material](#) subfeature where the permeability  $\kappa$  (SI unit:  $\text{m}^2$ ) and porosity  $\epsilon_p$  (dimensionless) are specified.

### COORDINATE SYSTEM SELECTION

Select a coordinate system from the **Coordinate system** list for the interpretation of directions in anisotropic material properties. The default is the **Global coordinate system**, and the list contains any additional orthonormal coordinate system (except boundary coordinate systems) added under the **Definitions** node.

The subnodes inherit these coordinate system settings. In particular, the **Permeability** or **Hydraulic conductivity** (in the [Fracture Material](#) subnode) should be set according to the coordinate system selected in this section.

### APERTURE

Enter a value for the **Fracture thickness**  $d_f$ .

### FLOW MODEL

Define if the flow follows a linear or nonlinear pressure-velocity relationship.

- **Darcian flow** (default) defines a linear relationship using [Equation 5-18](#) and [Equation 5-19](#).
- **Non-Darcian flow** defines a nonlinear relationship using [Equation 5-18](#) and the pressure-velocity relationship

$$\nabla_T p = -\frac{\mu}{\kappa} \mathbf{u} - \beta \rho |\mathbf{u}| \mathbf{u}$$

where the nonlinear parameter  $\beta$  (SI unit:  $1/\text{m}$ ) is further specified in the [Fracture Material](#) subfeature.

### STORAGE MODEL

[Equation 5-18](#) can also be formulated with respect to a storage term.

$$\rho S \frac{\partial p}{\partial t} + \nabla \cdot \rho \left[ -\frac{\kappa}{\mu} (\nabla p) \right] = Q_m$$

The storage coefficient  $S$  can be interpreted as the weighted compressibility of the porous material and the fluid. Define the time dependent storage term by selecting one of the following options from the list:

- **From density and porosity** (default), uses the formulation of [Equation 5-18](#)
- **Linearized storage**, where the following linear equation is used to define the storage:

$$S = \varepsilon_p \chi_f + (1 - \varepsilon_p) \chi_p$$

- **User defined** to directly specify the storage coefficient  $S$



- [About Darcian and Non-Darcian Flow](#) in the *Porous Media Flow Module User's Guide*
- [Storage Models](#) in the *Subsurface Flow Module User's Guide*

## FRACTURE MODEL

Choose between two options to model fractures that have different characteristics.

- **Highly conductive fracture** represents a fracture filled with a highly permeable material.
- **Thin conducting barrier** represents a fracture that is filled with a low permeable material and therefore acts as a barrier for the flow which adds a jump in the pressure across the boundary:

$$-\mathbf{n}_{u,d} \cdot (\rho \mathbf{u})_{u,d} = \rho \frac{(p_{d,u} - p_{u,d}) \kappa_b}{d_b \mu}$$

The barrier thickness  $d_b$  and permeability  $\kappa_b$  are defined in the [Fracture Material](#) subnode.

In addition, either on the upside, downside, or on both sides a highly conductive fracture material is present and [Equation 5-18](#) and [Equation 5-19](#) are solved for the highly conductive side. Further specifications are done in the [Fracture Material](#) subnode.



Note that the option to specify the **Fracture Model** is only available for the Fracture feature within the Darcy's Law interface.

For the [Fracture](#) boundary node several subnodes are available from the context menu (right-click the parent node) or from the **Physics** toolbar, **Attributes** menu. As they are almost identical to the boundary conditions of the Fracture Flow interface, see [Domain, Boundary, Edge, Point, and Pair Nodes for the Fracture Flow Interface](#) in

the *Subsurface Flow User's Guide* for further description. Note that **Precipitation** is only available for the Fracture Flow interface.



This feature requires a specific license. For a detailed overview of the functionality available in each product, visit [www.comsol.com/products/specifications/](http://www.comsol.com/products/specifications/).



*Flow in a Fractured Reservoir*: Application Library path  
**Subsurface\_Flow\_Module/Fluid\_Flow/fractured\_reservoir\_flow**

## LOCATION IN USER INTERFACE

### *Context Menus*

**Darcy's Law** > **Fracture**

**Richards' Equation** > **Fracture**

**Fracture Flow** > **Fracture**

### *Ribbon*

Physics tab with *interface* as **Darcy's Law** or **Richards' Equations** selected:

**Boundaries** > *interface* > **Fracture**

With **Fracture Flow** selected:

**Boundaries** > **Fracture**

### *Fluid (Fracture)*

This node defines the material properties of the fluid of the **Fracture** parent node. The fluid can be specified as general gas or liquid or as an ideal gas.

## MODEL INPUT

This section contains fields and values that are inputs for expressions defining material properties. If such user-defined property groups are added, the model inputs appear here.

## FLUID PROPERTIES

The available options for the **Fluid type** are **Gas/Liquid** (default) or **Ideal gas**. The selection determines how the density and compressibility of the fluid are set. The latter

is only required if a linearized storage model has been selected in the parent [Fracture](#) node. For all fluid types specify the dynamic viscosity  $\mu$  (SI unit: Pa·s).

#### *Gas/Liquid*

This option specifies the **Density** and the **Compressibility** for a general gas or liquid.

#### *Ideal Gas*

For **Ideal gas** it uses the ideal gas law to describe the fluid. In this case, specify the thermodynamics properties. Select a **Gas constant type** — **Specific gas constant**  $R_s$  (the default) or **Mean molar mass**  $M_n$  (SI unit: J/(mol·K)). For **Mean molar mass** the universal gas constant  $R = 8.314$  J/(mol·K) is used as the built-in physical constant. For both properties, the defaults use values **From material**. For **User defined** enter another value or expression.

If required by a **Storage Model**, the **Compressibility** of the ideal gas is calculated as  $\chi_f = 1/p_A$  with the absolute pressure  $p_A$  (Pa).



---

If **Hydraulic conductivity** is selected as the **Permeability model** (see the [Fracture Material](#) section), dynamic viscosity is not available. The hydraulic conductivity is defined using a combination of fluid and fracture material properties and replaces the need of defining the dynamic viscosity.

---

#### **LOCATION IN USER INTERFACE**

A default **Fluid** node is automatically added to the [Fracture](#) node.

#### *Context Menus*

**Darcy's Law** > **Fracture** > **Fluid**

**Richards' Equation** > **Fracture** > **Fluid**

**Fracture Flow** > **Fracture** > **Fluid**

#### *Fracture Material*

---

This node defines the porosity and material properties of the solid matrix of the [Fracture](#) parent node.

#### **MODEL INPUT**

This section contains fields and values that are inputs for expressions defining material properties. If such user-defined property groups are added, the model inputs appear here.

## BARRIER PROPERTIES

This section appears if the **Thin conducting barrier** option for the **Fracture model** is chosen in the parent [Fracture](#) feature.

Enter the values for the barrier thickness  $d_b$  and permeability  $\kappa_b$ .

Note that the **Thin Conductive barrier** option is only available for the Fracture feature within the Darcy's Law interface.

## FRACTURE MATERIAL PROPERTIES

If the **Thin conducting barrier** option for the **Fracture model** is chosen in the parent [Fracture](#) feature you can specify the **Conductive layer position** here. Choose between **Both sides**, **Upside**, and **Downside**. A sketch above shows the position of conductive layers and barrier within the fracture.

The **Porosity**  $\varepsilon_p$  of the fracture material is taken **From material** by default. Select **User defined** to enter a value or expression for  $\varepsilon_p$ .

If required by a **Storage model** in the parent node, specify the **Effective compressibility** of the porous matrix. The default value is  $\chi_p = 10^{-4}$  1/Pa.

Select a **Permeability model** to specify the capacity of the fracture material to transmit flow. Which options are available depends on the **Flow model** setting in the parent node.

- Select **Permeability** (default) to define the permeability of the fracture material.
- Select **Hydraulic conductivity** or define a combination of fluid permeability and dynamic viscosity. For **Hydraulic conductivity**  $K$  (SI unit: m/s) select **Isotropic** to define a scalar value or **Diagonal** or **Symmetric** to define a tensor value. The default is  $2.94 \cdot 10^{-4}$  m/s.
- Select **Cubic law** to define the permeability from the fracture thickness specified in the parent node and the roughness factor  $f_f$ .

If the Non-Darcian Flow Model is selected in the parent [Fracture](#) feature enter a value for the **Inertial resistance coefficient**  $\beta$ .



- [About Darcian and Non-Darcian Flow](#) in the *Porous Media Flow Module User's Guide*
  - [Permeability Models](#) in the *Porous Media Flow Module User's Guide*
- 

## LOCATION IN USER INTERFACE

A default **Fracture Material** node is automatically added to the [Fracture](#) node.



*Context Menus*

**Darcy's Law > Fracture > Fracture Material**

**Richards' Equation > Fracture > Fracture Material**

**Fracture Flow > Fracture > Fracture Material**

# The Free and Porous Media Flow, Brinkman Interface

The **Free and Porous Media Flow, Brinkman (fp)** interface (  ) is found under the **Porous Media and Subsurface Flow** branch (  ) when adding a physics interface. It is used to compute fluid velocity and pressure fields of single-phase flow where free flow is connected to porous media. The Free and Porous Media Flow, Brinkman interface is used over at least two different domains: a free channel and a porous medium. The physics interface is well suited for transitions between slow flow in porous media, governed by the Brinkman equations, and fast flow in channels described by the Navier–Stokes equations. Fluids with varying density can be included at Mach numbers below 0.3. Also the viscosity of a fluid can vary, for example, to describe non-Newtonian fluids. The physics interface can be used for stationary and time-dependent analyses.

When this physics interface is added, the following default nodes are also added in the **Model Builder** — **Fluid Properties**, **Wall**, and **Initial Values**. Then, from the **Physics** toolbar, add a **Porous Medium** node to be used on the domain selection corresponding to the porous media, or add other nodes that implement, for example, boundary conditions and volume forces. You can also right-click **Free and Porous Media Flow, Brinkman** to select physics features from the context menu.

## SETTINGS

The **Label** is the default physics interface name.

The **Name** is used primarily as a scope prefix for variables defined by the physics interface. Refer to such physics interface variables in expressions using the pattern `<name>.<variable_name>`. In order to distinguish between variables belonging to different physics interfaces, the `name` string must be unique. Only letters, numbers, and underscores (`_`) are permitted in the **Name** field. The first character must be a letter.

The default **Name** (for the first physics interface in the model) is `fp`.

## PHYSICAL MODEL

### *Compressibility*

By default the physics interface uses the **Incompressible flow** formulation of the Navier–Stokes and Brinkman equations to model constant density flow. If required, select

**Weakly compressible flow** from the **Compressibility** list, to account for small variations in the density, which are only dependent on the temperature (nonisothermal flow) or **Compressible flow (Ma<0.3)** for fully compressible flow. However, for the flow modeled with this physics interface, the Mach number must be below 0.3.

#### *Swirl Flow*

For 2D axisymmetric components, select the **Swirl flow** checkbox to include the swirl velocity component, that is the velocity component  $u_\phi$  in the azimuthal direction. While  $u_\phi$  can be nonzero, there can be no gradients in the  $\phi$  direction. Note that this feature is only available for specific modules. Visit [www.comsol.com/products/specifications/](http://www.comsol.com/products/specifications/) for a detailed overview.

#### *Neglect Inertial Term*

Select the **Neglect inertial term (Stokes flow)** checkbox if the inertial forces are small compared to the viscous forces.

#### *Enable porous media domains*

The **Enable porous media domains** checkbox is selected by default to solve the Brinkman equations in porous domains. If it is cleared, the **Porous Medium** node is no longer available in this interface.

#### *Include Gravity*

Gravity is not included by default. Select the **Include gravity** checkbox to activate the acceleration of gravity. This automatically adds a global **Gravity** feature node to the interface model tree, and the buoyancy force is included in the Equations.

Also, when the **Include gravity** checkbox is selected, the **Use reduced pressure** option changes the pressure formulation from using the total pressure (default) to using the reduced pressure. This option is suitable for configurations where the density changes are very small; otherwise, the default formulation can be used. For more information, see [Gravity](#).

#### *Rotating Frame*

When the **Rotating Frame** checkbox is selected, a global **Rotating Frame** feature is shown in the interface model tree, and the fictitious Coriolis, centrifugal and Euler forces, stemming from the change to a non-inertial frame of reference, are included in the Navier–Stokes equations. Note that this feature is only available for specific modules. Visit [www.comsol.com/products/specifications/](http://www.comsol.com/products/specifications/) for a detailed overview.

For 2D components, the **Gravity** feature and the **Rotating Frame** feature are mutually exclusive, and thus can not be selected simultaneously. For 2D axisymmetric

components, the **Rotating Frame** checkbox and feature are only available when also the **Swirl flow** checkbox is selected.

When the **Rotating Frame** checkbox is selected, the **Use reduced pressure** option changes the pressure formulation from using the total pressure (default) to using the reduced pressure. This option is suitable for configurations where the density changes are very small; otherwise, the default formulation can be used. For more information, see [Rotating Frame](#)

#### *Include Buoyancy-Induced Turbulence*

When either the **Gravity** or the **Rotating Frame** checkbox is selected, and a turbulence model that solves for the turbulent kinetic energy,  $k$ , is used, the **Include buoyancy-turbulence** checkbox is available. When selected, the **Buoyancy contribution** is by default set to **Automatic from multiphysics**. Contributions are only obtained from multiphysics couplings that support buoyancy-induced turbulence, such as Nonisothermal Flow. If the **Buoyancy contribution** is switched to **Used defined**, a text field for the **Turbulent Schmidt number** appears.

When the **Incompressible flow** or the **Weakly compressible flow** option is selected, the **Hydrostatic pressure approximation** checkbox is available (selected by default). See also [Theory for Buoyancy-Induced Turbulence](#) in the *CFD Module User's Guide*.

#### *Porous Treatment of No Slip Condition*

Choose how the **No Slip** condition on interior boundaries should be treated. The options are **Standard no slip formulation** and **Porous slip** (default). The latter option provides a unified treatment when the porous matrix is fully resolved as well as when it is under resolved ensuring a smooth transition between regions with different resolutions; see No Slip under **Wall** in [The Laminar Flow and Creeping Flow Interfaces](#) section.

#### *Reference Pressure Level*

Enter a **Reference pressure level**  $p_{\text{ref}}$  (SI unit: Pa). The default value is 1 [atm].

#### *Reference Temperature*

Enter a **Reference temperature**  $T_{\text{ref}}$  (SI unit: K). The default value is 293.15 [K].

#### *Reference Position*

If **Include gravity** or **Rotating frame** is selected, a **Reference position**  $r_{\text{ref}}$  (SI unit: m) can be specified which is then used for the calculation of the hydrostatic pressure.

## TURBULENCE

Turbulent flow can be simulated by changing the **Turbulence model type** to **RANS-EVM** (Reynolds-Averaged Navier–Stokes, eddy-viscosity model), **RANS-RSM** (Reynolds-Averaged Navier–Stokes, Reynolds stress model), or **Large Eddy Simulation** (which is only available in 3D). If turbulent flow is activated, you can choose the **Turbulence model** and between different options for **Wall treatment**. For a description of the turbulence models, wall treatment options, and turbulence model parameters, see [Theory for the Turbulent Flow Interfaces](#) in the *CFD Module User’s Guide*.

## DEPENDENT VARIABLES

The following dependent variables (fields) are defined for this physics interface — the **Velocity field  $\mathbf{u}$**  (SI unit: m/s) and its components, and the **Pressure  $p$**  (SI unit: Pa).



- [Domain, Boundary, Point, and Pair Nodes for the Free and Porous Media Flow, Brinkman Interface](#)
- [Theory for the Free and Porous Media Flow, Brinkman Interface](#)

### *Domain, Boundary, Point, and Pair Nodes for the Free and Porous Media Flow, Brinkman Interface*

The [Free and Porous Media Flow, Brinkman Interface](#) has the following domain, boundary, point, and pair nodes, listed in alphabetical order, available from the **Physics** ribbon toolbar (Windows users), **Physics** context menu (Mac or Linux users), or right-click to access the context menu (all users).



In general, to add a node, go to the **Physics** toolbar, no matter what operating system you are using. Subnodes are available by clicking the parent node and selecting it from the **Attributes** menu.

- [Electrode–Electrolyte Interface Coupling](#)
- [Fluid Properties](#)
- [Gravity](#)
- [Initial Values](#)
- [Porous Electrode Coupling](#)
- [Porous Medium](#)
- [Rotating Frame](#)
- [Mass Source](#)
- [Volume Force](#)
- [Wall](#)

Note that some features are only available with certain COMSOL products (see [www.comsol.com/products/specifications/](http://www.comsol.com/products/specifications/)).



See the Transport of Diluted Species interface for [Porous Electrode Coupling](#) and [Reaction Coefficients](#).

The following nodes (listed in alphabetical order) are described for the Laminar Flow interface in the *COMSOL Multiphysics Reference Manual*:

- [No Viscous Stress](#)
- [Flow Continuity](#)
- [Inlet](#)
- [Line Mass Source](#)
- [Outlet](#)
- [Open Boundary](#)
- [Periodic Flow Condition](#)
- [Point Mass Source](#)
- [Pressure Point Constraint](#)
- [Symmetry](#)



In the *COMSOL Multiphysics Reference Manual* see [Table 2-4](#) for links to common sections and [Table 2-5](#) to common feature nodes. You can also search for information: press F1 to open the **Help** window or Ctrl+F1 to open the **Documentation** window.

### *Fluid Properties*

Use the **Fluid Properties** node to define the fluid material, density, and dynamic viscosity.

#### **FLUID PROPERTIES**

The default **Fluid material** uses the **Domain material** (the material defined for the domain). Select another material as needed.

The default **Density**  $\rho$  (SI unit:  $\text{kg}/\text{m}^3$ ) uses values **From material** based on the **Fluid material** selection. For **User defined** enter another value or expression. The default is  $0 \text{ kg}/\text{m}^3$ .

The **Dynamic viscosity**  $\mu$  (SI unit: Pa·s) uses values **From material** based on the **Fluid material** selection. For **User defined** enter another value or expression. The default is  $0 \text{ Pa}\cdot\text{s}$ .

## *Porous Medium*

---

The **Porous Medium** node adds the Brinkman equations (excluding any mass sources) to the interface. It has two default subfeatures — the **Fluid** subfeature where the fluid density  $\rho$  (SI unit:  $\text{kg}/\text{m}^3$ ) and dynamic viscosity  $\mu$  (SI unit:  $\text{Pa}\cdot\text{s}$ ) are defined and the **Porous Matrix** subfeature where the permeability  $\kappa$  (SI unit:  $\text{m}^2$ ) and porosity  $\varepsilon_p$  (dimensionless) are specified.

### **FLOW MODEL**

Define if the flow follows a linear or nonlinear pressure-velocity relationship.

- **Darcian flow** (default) defines a linear relationship characteristic for low Reynolds number laminar flows.
- **Non-Darcian flow** defines a nonlinear relationship due to inertial or turbulence effects.

### **POROUS MEDIUM TURBULENCE MODEL**

Defines a model which complements the basic turbulence model and accounts for the influence of the porous matrix on turbulent flow in Porous Media.

- **Default** and **Nakayama–Kuwahara** specify **Coefficient of subgrid turbulence generation by porous matrix**  $C_{\text{stpm}}$  which by default is set to 0.212.
- **Pedras-de Lemos** asks to specify **Choice of the Pedras-de Lemos model coefficient**. When **User defined** is chosen, specify **Coefficient of subgrid turbulence generation by porous matrix**  $C_{\text{stpm}}$  with default value 0.212. Choosing **Original** results in  $C_{\text{stpm}} = 0.28 \cdot \sqrt{\varepsilon_p}$ , while choosing **Recalibrated** results in  $C_{\text{stpm}} = 0.18$ .

## *Fluid*

---

This node defines the material properties of the fluid of the **Porous Medium** parent node.

### **MODEL INPUT**

This section contains fields and values that are inputs for expressions defining material properties. If such user-defined property groups are added, the model inputs appear here.

### **FLUID PROPERTIES**

Specify the **Density**  $\rho$  and the **Dynamic viscosity**  $\mu$  (SI unit:  $\text{Pa}\cdot\text{s}$ ) of the fluid. The defaults use values **From material**, for **User defined** enter a value or expression.

The dynamic viscosity describes the relationship between the shear stresses and the shear rate in a fluid. Intuitively, water and air have a low viscosity, and substances often described as thick, such as oil, have a higher viscosity.

If the Polymer Flow Module license is available and for Darcian flow, also non-Newtonian models are available and the **Constitutive Relation** can be switched between **Specify dynamic viscosity** (default) or **Inelastic non-Newtonian**.

#### *Constitutive Relation*

Use the default option to either get the dynamic viscosity from a material, or to add a user defined expression. The default option lets you either use the dynamic viscosity from a material or define it with a custom expression. The **Inelastic non-Newtonian** option provides several models and defines the **Apparent shear rate**.

#### *Inelastic Non-Newtonian*

The following inelastic non-Newtonian Models are available for the **Fluid** feature under the **Porous Medium** feature:

- Power Law
- Carreau
- Carreau–Yasuda
- Cross
- Cross–Williamson
- Sisko

The setup of these models in porous media is similar to their definition under the [Fluid Properties](#) feature.

#### *Apparent Shear Rate*

To define the apparent shear rate  $\dot{\gamma}_{app}$ , either enter a user-defined expression for the correction factor ( $\alpha$ ) or choose the **Capillary bundle approach** from the list and provide a value for the Tortuosity factor ( $C$ ).



- Read more about the theory of [Non-Newtonian Fluids in Porous Media](#) in the *Polymer Flow Module User's Guide*
-

This node defines the porosity and material properties of the solid matrix of the **Porous Medium** parent node.

#### **MODEL INPUT**

This section contains fields and values that are inputs for expressions defining material properties. If such user-defined property groups are added, the model inputs appear here.

#### **MATRIX PROPERTIES**

The **Porosity**  $\varepsilon_p$  (a dimensionless number between 0 and 1) uses by default the value **From material**. For **User defined** the default value is 1 which is equivalent to free flow.

Select a **Permeability model** to specify the capacity of the porous material to transmit flow. Depending on the **Flow model** selection in the parent **Porous Medium** feature node you can choose between the following options:

- **Permeability** (the default) to directly enter the permeability of the porous matrix or **Kozeny–Carman** to define the permeability from the porosity and mean **Particle diameter** for **Darcian** flow or
- **Forchheimer**, **Ergun**, or **User defined** for **Non-Darcian** flow.

Note that some of these options are only available for certain modules. For a detailed overview of the functionality available in each product, visit [www.comsol.com/products/specifications/](http://www.comsol.com/products/specifications/).

The default **Permeability**  $\kappa$  (SI unit:  $\text{m}^2$ ) uses the value **From material**, as defined by the **Porous material** list. For **User defined** select **Isotropic** to define a scalar value or **Diagonal** or **Symmetric** to define a tensor value.

For **Kozeny–Carman**, enter the mean **Particle diameter**  $d_p$  (SI unit: m), the default value is 0.5 mm.

In case a **Non-Darcian** flow model is chosen in the parent node, **Forchheimer** is the default selection for the **Permeability model**. For **Forchheimer**, the default **Permeability**  $\kappa$  (SI unit:  $\text{m}^2$ ) uses the value **From material**. Furthermore, the dimensionless **Forchheimer parameter**  $c_F$  can be defined. The default value is 0.55.

If **Ergun** is selected, enter the mean **Particle diameter**  $d_p$  (default value: 0.5 mm). The permeability  $\kappa$  is then calculated using [Equation 2-4](#) in the *Porous Media Flow Module User's Guide*.

For the option **User defined** the default **Permeability** uses the option **From material**. Furthermore, the **Inertial resistance coefficient**  $\beta$  (SI unit: 1/m) can be defined. Its default value is 0.0.



- [About Darcian and Non-Darcian Flow](#) in the *Porous Media Flow Module User's Guide*
- [Permeability Models](#) in the *Porous Media Flow Module User's Guide*

---

### *Mass Source*

Enter a value or expression for an optional mass source (or sink) **Source term**  $Q_m$  (SI unit:  $\text{kg}/(\text{m}^3 \cdot \text{s})$ ). This term accounts for mass deposit or mass creation within porous domains. The physics interface assumes that the mass exchange occurs at zero velocity.

---

### *Volume Force*

The **Volume Force** node specifies the force  $\mathbf{F}$  on the right-hand side of the Navier–Stokes or Brinkman equations, depending on whether a [Fluid Properties](#) or [Porous Medium](#) node is active on the domain. It then acts on each fluid element in the specified domains.

#### **VOLUME FORCE**

Enter the components of the **Volume force**  $\mathbf{F}$  (SI unit:  $\text{N}/\text{m}^3$ ).

---

### *Porous Electrode Coupling*

Use the **Porous Electrode Coupling** node to define a mass source based on the volumetric current densities of one or multiple [Porous Electrode Reaction](#) nodes in an Electrochemistry interface.

The source (or sink) is proportional to the **Molar mass (kg/mol)** of the reacting species, the current densities and the stoichiometric coefficients according to Faraday's law as defined by summation over the Reaction Coefficient subnodes.

#### **SPECIES**

Based on the number of species required for the model, use the **Add** (  $+$  ) and **Delete** (  $\times$  ) buttons under the table to add or remove **Species**. Then enter a value for the **Molar mass (kg/mol)** in the applicable rows for each species.

The setting in the table will determine the number of available fields for entering the stoichiometric coefficients of the Reaction Coefficient subnodes.

### *Initial Values*

---

The **Initial Values** node adds initial values for the velocity field and the pressure that can serve as an initial condition for a transient simulation or as an initial guess for a nonlinear solver.

#### **INITIAL VALUES**

Enter initial values or expressions for the **Velocity field  $\mathbf{u}$**  (SI unit: m/s) and for the **Pressure  $p$**  (SI unit: Pa). The default values are 0 m/s and 0 Pa, respectively.

### *Gravity*

---

The **Gravity** global feature is automatically added when **Include gravity** is selected at the interface level in the **Physical Model** settings. It defines the gravity forces from the **Acceleration of gravity** value.

This feature requires a specific license. For a detailed overview of the functionality available in each product visit [www.comsol.com/products/specifications/](http://www.comsol.com/products/specifications/).

#### **ACCELERATION OF GRAVITY**

The **Acceleration of gravity** (SI unit m/s, default value  $-g_{\text{const}}\mathbf{e}_z$  in 2D axial symmetry and 3D and  $-g_{\text{const}}\mathbf{e}_y$  in 2D) is used to define the gravity forces. It should be a global quantity.

When in addition to **Include gravity** also **Rotating frame** is selected (only possible in 3D and 2D axial symmetry), the **Project gravity vector on rotation axis** checkbox is available (by default selected).

### *Rotating Frame*

---

The **Rotating Frame** global feature is automatically added when **Rotating frame** is selected at the interface level in the **Physical Model** settings. It defines the fictitious Coriolis, centrifugal, and Euler forces from the settings in the **Rotating Frame** section.

This feature requires a specific license. For a detailed overview of the functionality available in each product visit [www.comsol.com/products/specifications/](http://www.comsol.com/products/specifications/).

## ROTATING FRAME

In 2D, the axis of rotation is an out-of-plane axis. In this case, select a **Rotation axis base point**  $\mathbf{r}_{bp}$ .

In 2D axial symmetry, the axis of rotation is the symmetry axis.

In 3D, select an **Axis of rotation** — **x-axis**, **y-axis**, **z-axis** (the default), or **User defined**. For **User defined** enter a **Rotation axis direction**  $\mathbf{e}_{ax}$  and a **Rotation axis base point**  $\mathbf{r}_{bp}$ .

Select a **Rotation speed** — **Angular velocity**, **Revolutions per time**, or **User defined**.

- For **Angular velocity**, enter a value for the angular velocity magnitude  $\Omega_f$ .
- For **Revolutions per time**, enter an RPM value.
- For **User defined**, enter the **Rotation angle**  $\alpha$  in radians as function of time (the variable  $\tau$ ).

In case **Angular velocity** or **Revolutions per time** is selected, also select a **Rotational direction** — **Counterclockwise** (the default) or **Clockwise**.

## *Electrode–Electrolyte Interface Coupling*

---

Use the **Electrode–Electrolyte Interface Coupling** node to define a combined wall and inflow/outflow boundary condition based on current densities of one or multiple [Electrode Reaction](#) nodes in an Electrochemistry interface.

The flow is proportional to the **Molar mass (kg/mol)** of the reacting species, the current densities and the stoichiometric coefficients according to Faraday’s law as defined by summation over the Reaction Coefficient subnodes.

## TANGENTIAL VELOCITY CONDITION

For information about this section, see the [Wall](#) node. **No slip** is the default, but **Slip** may in some cases be a more applicable, for instance if a gas diffusion electrode is modeled as a boundary condition.

## SPECIES

Based on the number of species required for the model, use the **Add** ( **+** ) and **Delete** ( **✖** ) buttons under the table to add or remove **Species**. Then enter a value for the **Molar mass (kg/mol)** in the applicable rows for each species.

The setting in the table will determine the number of available field for entering the stoichiometric coefficients of the Reaction Coefficient subnodes.

## Wall

---

The **Wall** node includes a set of boundary conditions describing fluid-flow conditions at stationary, moving, and leaking walls.

### BOUNDARY CONDITION

Select a **Boundary condition** for the wall.

- [No Slip](#)<sup>1</sup>
- [Slip](#)
- [Leaking Wall](#)

#### No Slip

**No slip** is the default boundary condition for a stationary solid wall for laminar flow (and SST, Low Re  $k$ - $\epsilon$ , Algebraic  $y$ Plus, L-VEL, and Spalart–Allmaras turbulence models). The condition prescribes  $\mathbf{u} = 0$ ; that is, the fluid at the wall is not moving.

#### Slip

The **Slip** option prescribes a no-penetration condition,  $\mathbf{u} \cdot \mathbf{n} = 0$ . It is implicitly assumed that there are no viscous effects at the slip wall and hence, no boundary layer develops. From a modeling point of view, this can be a reasonable approximation if the main effect of the wall is to prevent fluid from leaving the domain.

#### Leaking Wall

This boundary condition can be used to simulate a wall where fluid is leaking into or leaving the domain with the velocity  $\mathbf{u} = \mathbf{u}_1$  through a perforated wall. The components of the **Fluid velocity**  $\mathbf{u}_1$  on the leaking wall should be specified.

### CONSTRAINT SETTINGS

This section is displayed by clicking the **Show** button (  ) and selecting **Advanced Physics Options**.



- [The Moving Mesh Interface](#) in the *COMSOL Multiphysics Reference Manual*
-

# The Free and Porous Media Flow, Darcy Interface

The **Free and Porous Media Flow, Darcy** interface (  ) combines the **Darcy's Law** and **Laminar Flow** interfaces to compute fluid velocity and pressure fields where free flow is connected to porous media. The physics interface is suited for situations when both the free flow and the flow in the porous media are laminar.

When a predefined **Free and Porous Media Flow, Darcy** interface is added from the **Porous Media and Subsurface Flow** branch (  ) of the **Model Wizard** or **Add Physics** window, the **Darcy's Law** and **Laminar Flow** interfaces are added to the Model Builder. In addition, the **Multiphysics** node is added, which automatically includes the **Free and Porous Media Flow Coupling** multiphysics coupling.

## *On the Constituent Physics Interfaces*

The **Darcy's Law** interface is used to simulate fluid flow through interstices in a porous medium. It can be used to model low-velocity flows in media where the permeability and porosity are very small, and for which the pressure gradient is the major driving force and the flow is mostly influenced by the frictional resistance within the pores.

The **Laminar Flow** interface is used to compute the velocity and pressure for a fluid flow in the laminar flow regime. A flow will remain laminar as long as the Reynolds number is below a certain critical value. At higher Reynolds numbers, disturbances have a tendency to grow and cause transition to turbulence.

## **SETTINGS FOR PHYSICS INTERFACES AND COUPLING FEATURES**

When physics interfaces are added using the predefined couplings, for example **Free and Porous Media Flow, Darcy**, specific settings are included with the physics interfaces and the coupling features.

However, if physics interfaces are added one at a time, followed by the coupling features, these modified settings are not automatically included.

## *Free and Porous Media Flow Coupling (Multiphysics Coupling)*

---

The **Free and Porous Media Flow Coupling** multiphysics coupling node (  ) bidirectionally links the **Laminar Flow** and **Darcy's Law** interfaces.

## SETTINGS

The **Label** is the default multiphysics coupling feature name.

The **Name** is used primarily as a scope prefix for variables defined by the coupling node. Refer to such variables in expressions using the pattern `<name>.<variable_name>`. In order to distinguish between variables belonging to different coupling nodes or physics interfaces, the `name` string must be unique. Only letters, numbers, and underscores (`_`) are permitted in the **Name** field. The first character must be a letter.

The default **Name** (for the first multiphysics coupling feature in the model) is `nsd1`.

## DOMAIN SELECTION

When nodes are added from the context menu, you can select **Manual** (the default) from the **Selection** list to choose specific domains to define the multiphase flow coupling, or select **All domains** as needed.

When the **Free and Porous Media Flow Coupling** is added as an effect of adding a Free and Porous Media Flow, Darcy multiphysics interface, the selection is the intersection of the boundaries of the participating physics interfaces.

Only boundaries that are active in the participating physics interfaces (which are chosen from the **Coupled Interfaces** selection list) can be selected.

## COUPLED INTERFACES

This section defines the physics involved in the multiphysics coupling. The **Free flow** and **Porous media flow** lists include all applicable physics interfaces.

The default values depend on how the coupling node is created.

- If it is added from the **Physics** ribbon (Windows users), **Physics** contextual toolbar (Mac and Linux users), or context menu (all users), then the first physics interface of each type in the component is selected as the default.
- If it is added automatically when a multiphysics interface is selected in the **Model Wizard** or **Add Physics** window, then the two participating physics interfaces are selected.

You can also select **None** from either list to uncouple the Free and Porous Media Flow Coupling node from a physics interface. If the physics interface is removed from the **Model Builder**, for example **Darcy's Law** is deleted, then the **Porous media flow** list defaults to **None** as there is nothing to couple to.

## COUPLING SETTINGS

This section defines the settings for the **Free flow boundary condition**.

- When **No slip** is selected, the tangential component of the fluid velocity at the free-porous interface on the free-flow side (computed in the **Free flow** interface) is set to zero.
- When **Continuous tangential velocity** is selected, the tangential velocity component of the flow on both sides of the free-porous interface is continuous. In addition, continuity of normal stresses and conservation of mass across the interface are ensured.
- When **Beavers–Joseph** is selected, the difference of the tangential velocity components of the flow on both sides of the free-porous interface is proportional to the shear stress at the free-porous interface on the free-flow side. For this option, enter a value or expression for the **Beavers and Joseph parameter**  $a_{BJ}$  (dimensionless) that determines the proportionality. In addition, select the checkbox **Use projected permeability** to use only the component of the permeability tensor in the direction of the difference of the tangential velocities on both sides of the interface, instead of the trace of the permeability tensor, in determining the proportionality.
- When **Beavers–Joseph–Saffman** is selected, the tangential velocity component of the flow at the free-porous interface on the free-flow side is proportional to the shear stress at the interface on the free-flow side. For this option also, enter a value or expression for the **Beavers and Joseph parameter**  $a_{BJ}$  (dimensionless) that determines the proportionality. In addition, select the checkbox **Use projected permeability** to use only the component of the permeability tensor in the direction of the difference of the tangential velocities on both sides of the interface, instead of the trace of the permeability tensor, in determining the proportionality.
- When **Viscous slip** is selected, the difference of the tangential velocity components of the flow on the free-flow side and a user-supplied interfacial velocity is proportional to the shear stress at the free-porous interface on the free-flow side. Enter values for the **Slip length**  $L_s$  (SI unit: m, the default is  $1e-7$  m), and an **Interfacial velocity**  $\mathbf{u}_b$  (SI unit: m/s, the default is 0 m/s).

In all the above cases, additionally continuity of normal stresses and conservation of mass across the interface are ensured.

Select the **Include pressure jump across free-porous boundary** checkbox to specify an additional pressure jump  $p_j$  (SI unit: Pa, the default is 0 Pa), in order to model, for example, a resistive layer or other pressure losses at the free-porous interface.





---

Please find related information in the *CFD Module User's Guide*:

- [The Darcy's Law Interface](#)
  - [Theory for the Darcy's Law Interface](#)
  - [The Laminar Flow Interface](#)
  - [Theory for the Single-Phase Flow Interfaces](#)
  - [Theory for the Free and Porous Media Flow, Darcy Interface](#)
-

# The Brinkman Equations Interface

The **Brinkman Equations (br)** interface (  ), found under the **Porous Media and Subsurface Flow** branch (  ) when adding a physics interface, is used to compute fluid velocity and pressure fields of single-phase flow in porous media in the laminar flow regime. The physics interface extends Darcy's law to describe the dissipation of the kinetic energy by viscous shear, similar to the Navier–Stokes equations. Fluids with varying density can be included at Mach numbers below 0.3. Also the viscosity of a fluid can vary, for example, to describe non-Newtonian fluids. To simplify the equations, select the Stokes–Brinkman flow feature to reduce the dependence on inertial effects when the Reynolds number is significantly less than 1. The physics interface can be used for stationary and time-dependent analyses.

The main node is the Porous Medium feature, which adds the Brinkman equations and provides interfaces for defining the fluid material and the porous matrix.

When this physics interface is added, the following default nodes are also added in the **Model Builder — Porous Medium, Wall** (the default boundary type, using **No slip** as the default boundary condition), and **Initial Values**. Then, from the **Physics** toolbar, add other nodes that implement, for example, boundary conditions and volume forces. You can also right-click **Brinkman Equations** to select physics features from the context menu.

The boundary conditions are essentially the same as for the Laminar Flow interface. Differences exist for the following boundary types: Outlet, Symmetry, Open Boundary, and Boundary Stress where the viscous part of the stress is divided by the porosity to appear as

$$\frac{1}{\varepsilon_p} \left\{ \mu (\nabla \mathbf{u} + (\nabla \mathbf{u})^T) - \frac{2}{3} \mu (\nabla \cdot \mathbf{u}) \mathbf{I} \right\}$$

In the *COMSOL Multiphysics Reference Manual* see [Table 2-4](#) for links to common sections such as **Discretization**, **Consistent Stabilization**, **Inconsistent Stabilization**, and **Advanced Settings**, all accessed by clicking the **Show** button (  ) and choosing the applicable option. You can also search for information: press F1 to open the **Help** window or Ctrl+F1 to open the **Documentation** window.

## SETTINGS

The **Label** is the default physics interface name.

The **Name** is used primarily as a scope prefix for variables defined by the physics interface. Refer to such physics interface variables in expressions using the pattern `<name>.<variable_name>`. In order to distinguish between variables belonging to different physics interfaces, the **name** string must be unique. Only letters, numbers, and underscores (`_`) are permitted in the **Name** field. The first character must be a letter.

The default **Name** (for the first physics interface in the model) is `br`.

## PHYSICAL MODEL

This node specifies the properties of the Brinkman Equations interface, which describe the overall type of fluid flow model.

### *Compressibility*

By default the physics interface uses the **Incompressible flow** formulation of the Brinkman equations to model constant density flow. Alternatively, from the **Compressibility** list select **Weakly compressible flow**, which should be used when the pressure dependency of the density can be neglected, or **Compressible flow (Ma<0.3)** to solve for the full compressible flow of which, however, the Mach number must be below 0.3.

### *Swirl Flow*

For 2D axisymmetric models, select the **Swirl flow** checkbox to include the swirl velocity component, that is the velocity component  $u_\phi$  in the azimuthal direction. While  $u_\phi$  can be nonzero, there can be no gradients in the  $\phi$  direction.

Note that this feature is only available for specific modules. See [www.comsol.com/products/specifications/](http://www.comsol.com/products/specifications/) for a detailed overview.

### *Neglect Inertial Term (Stokes–Brinkman Flow)*

The **Neglect inertial term (Stokes–Brinkman)** checkbox is selected by default to model flow at low Reynolds numbers for which the inertial term can be neglected. This results in the linear Stokes–Brinkman equations.

### *Include Gravity*

Gravity is not included by default. Select the **Include gravity** checkbox to activate the acceleration of gravity. This automatically adds a global **Gravity** feature node to the interface model tree, and the buoyancy force is included in the equations.

Note that this feature is only available for specific modules. See [www.comsol.com/products/specifications/](http://www.comsol.com/products/specifications/) for a detailed overview.

Also, when the **Include gravity** checkbox is selected, the **Use reduced pressure** option changes the pressure formulation from using the total pressure (default) to using the reduced pressure. This option is suitable for configurations where the density changes are very small; otherwise, the default formulation can be used. For more information, see [Gravity](#).

#### *Rotating Frame*

When the **Rotating Frame** checkbox is selected, a global **Rotating Frame** feature is shown in the interface model tree, and the fictitious Coriolis, centrifugal and Euler forces, stemming from the change to a non-inertial frame of reference, are included in the Navier–Stokes equations.

For 2D components, the **Gravity** feature and the **Rotating Frame** feature are mutually exclusive, and thus can not be selected simultaneously. For 2D axisymmetric components, the **Rotating Frame** checkbox and feature are only available when also the **Swirl flow** checkbox is selected.

When the **Rotating Frame** checkbox is selected, the **Use reduced pressure** option changes the pressure formulation from using the total pressure (default) to using the reduced pressure. This option is suitable for configurations where the density changes are very small; otherwise, the default formulation can be used. For more information, see [Rotating Frame](#)

#### *Include Buoyancy-Induced Turbulence*

When either the **Gravity** or the **Rotating Frame** checkbox is selected, and a turbulence model that solves for the turbulent kinetic energy,  $k$ , is used, the **Include buoyancy-turbulence** checkbox is available. When selected, the **Buoyancy contribution** is by default set to **Automatic from multiphysics**. Contributions are only obtained from multiphysics couplings that support buoyancy-induced turbulence, such as Nonisothermal Flow. If the **Buoyancy contribution** is switched to **Used defined**, a text field for the **Turbulent Schmidt number** appears.

When the **Incompressible flow** or the **Weakly compressible flow** option is selected, the **Hydrostatic pressure approximation** checkbox is available (selected by default). See also [Theory for Buoyancy-Induced Turbulence](#) in the *CFD Module User's Guide*.

#### *Porous Treatment of No Slip Condition*

Choose how the **No Slip** condition on **Wall** boundaries and **Interior Wall** boundaries adjacent to **Porous Medium** should be treated. The options are **Standard no slip formulation** and **Porous slip** (the default). The latter option provides a unified treatment when the porous matrix is fully resolved as well as when it is under resolved ensuring

a smooth transition between regions with different resolutions; see No Slip under [Wall](#) in [The Laminar Flow and Creeping Flow Interfaces](#) section.

#### *Reference Pressure Level*

Enter a **Reference pressure level**  $p_{\text{ref}}$  (SI unit: Pa). The default value is 1 [atm].

#### *Reference Temperature Level*

Enter a **Reference temperature level**  $T_{\text{ref}}$  (SI unit: K). The default value is 293.15 [K].

#### *Reference Position*

If **Include gravity** or **Rotating frame** is selected, a **Reference position**  $r_{\text{ref}}$  (SI unit: m) can be specified which is then used for the calculation of the hydrostatic pressure.

### **TURBULENCE**

Turbulent flow can be simulated by changing the **Turbulence model type** to **RANS-EVM** (Reynolds-Averaged Navier–Stokes, eddy-viscosity model). If **RANS-EVM** is activated, you can set the **Turbulence model** either to one of the algebraic turbulence models, **Algebraic yPlus** (the default) or **L-VEL**, or to one of the following two-equation turbulence models:  $k$ - $\epsilon$ , Low Reynolds Number  $k$ - $\epsilon$ . The **Wall treatment** is set to **Automatic** (default) or **Low Re** while **Wall functions** is the only option for  $k$ - $\epsilon$ .

For more information about turbulence modeling, see [Theory for the Turbulent Flow Interfaces](#) in the *CFD Module User's Guide*.

### **DEPENDENT VARIABLES**

The following dependent variables (fields) are defined for this physics interface — the **Velocity field**  $\mathbf{u}$  (SI unit: m/s) and its components, and the **Pressure**  $p$  (SI unit: Pa).

### **ADVANCED SETTINGS**

To display this section, click the **Show More Options** button (  ) and select **Advanced Physics Options** in the **Show More Options** dialog. Normally these settings do not need to be changed.

The **Use pseudo time stepping for stationary equation form** option adds pseudo time derivatives to the equation when the **Stationary equation** form is used in order to speed up convergence. When selected, a **CFL number expression** should also be defined. For

the default **Automatic** option, the local CFL number (from the Courant–Friedrichs–Lewy condition) is determined by a PID regulator.



- [Domain, Boundary, Point, and Pair Nodes for the Brinkman Equations Interface](#)
  - [Theory for the Brinkman Equations Interface](#)
- In the *COMSOL Multiphysics Reference Manual*:
- [Pseudo Time Stepping for Laminar Flow Models and Pseudo Time Stepping](#)
  - [Numerical Stability — Stabilization Techniques for Fluid Flow](#)
  - [Nitsche Constraints](#)

---

### *Domain, Boundary, Point, and Pair Nodes for the Brinkman Equations Interface*

---

The [Brinkman Equations Interface](#) has the following domain, boundary, point, and pair nodes, listed in alphabetical order, available from the **Physics** ribbon toolbar (Windows users), **Physics** context menu (Mac or Linux users), or right-click to access the context menu (all users).



In general, to add a node, go to the **Physics** toolbar, no matter what operating system you are using. Subnodes are available by clicking the parent node and selecting it from the **Attributes** menu.

These nodes are described in this section:

- [Porous Medium](#)
- [Initial Values](#)
- [Mass Source](#)
- [Gravity](#)
- [Volume Force](#)
- [Fluid Properties](#)
- [Rotating Frame](#)

The following nodes (listed in alphabetical order) are described for the Laminar Flow interface in the *COMSOL Multiphysics Reference Manual*:

- Flow Continuity
- Inlet
- Line Mass Source
- Boundary Stress
- Outlet
- Open Boundary
- Periodic Flow Condition
- Point Mass Source
- Pressure Point Constraint
- Symmetry
- Wall



In the *COMSOL Multiphysics Reference Manual* see [Table 2-4](#) for links to common sections and [Table 2-5](#) to common feature nodes. You can also search for information: press F1 to open the **Help** window or Ctrl+F1 to open the **Documentation** window.

### *Porous Medium*

The **Porous Medium** node adds the Brinkman equations: [Equation 4-34](#) and [Equation 4-35](#) (excluding any mass sources). It has two default subfeatures — the **Fluid** subfeature where the fluid density  $\rho$  (SI unit:  $\text{kg}/\text{m}^3$ ) and dynamic viscosity  $\mu$  (SI unit: Pa·s) are defined and the **Porous Matrix** subfeature where the permeability  $\kappa$  (SI unit:  $\text{m}^2$ ) and porosity  $\varepsilon_p$  (dimensionless) are specified.

#### **COORDINATE SYSTEM SELECTION**

Select a coordinate system from the **Coordinate system** list for the interpretation of directions in anisotropic material properties. The default is the **Global coordinate system**, and the list contains any additional orthonormal coordinate system (except boundary coordinate systems) added under the Definitions node.

The subnodes inherit these coordinate system settings. In particular, the **Permeability** (in the **Porous Matrix** subnode) should be set according to the coordinate system selected in this section.

## FLOW MODEL

Define if the flow follows a linear or nonlinear pressure-velocity relationship.

- **Darcian flow** (default) defines a linear relationship characteristic for low Reynolds number laminar flows.
- **Non-Darcian flow** defines a nonlinear relationship due to inertial or turbulence effects.

## POROUS MEDIUM TURBULENCE MODEL

If in the parent feature node a turbulence model other than **Algebraic yPlus** or **L-VEL** is selected, define a model which complements the basic turbulence model and accounts for the influence of the porous matrix on turbulent flow in porous media.

- For **Default** and **Nakayama–Kuwahara** specify the **Coefficient of subgrid turbulence generation by porous matrix**  $C_{\text{stpm}}$  which by default is set to 0.212.
- For **Pedras–de Lemos**, specify the **Choice of the Pedras–de Lemos model coefficient**. When **User defined** is chosen, specify the **Coefficient of subgrid turbulence generation by porous matrix**  $C_{\text{stpm}}$  with default value 0.212. Choosing **Original** results in  $C_{\text{stpm}} = 0.28 \cdot \sqrt{\epsilon_p}$ , while choosing **Recalibrated** results in  $C_{\text{stpm}} = 0.18$ .
- If **Turbulence model type** is **RANS-RSM**, specify the **Production of Reynolds stresses by porous matrix**. The default is **Isotropic** and the other option is **Streamwise**.

## DISTANCE EQUATION

This section is available for the turbulence models **Algebraic yPlus** or **L-VEL**. Select how the **Reference length scale**  $l_{\text{ref}}$  (SI unit: m) is defined — **Automatic** (default) or **Manual**:

- For **Automatic** the wall distance is automatically evaluated to one tenth of the shortest side of the geometry bounding box. This is usually quite accurate but it can sometimes give a too high value if the geometry consists of several slim entities. In such cases, define the reference length scale manually.
- For **Manual** it defines a different value or expression for the length scale. The default is 1 m.

$l_{\text{ref}}$  controls the result of the distance equation. Objects that are much smaller than  $l_{\text{ref}}$  are effectively be diminished while the distance to objects much larger than  $l_{\text{ref}}$  are accurately represented.

## LOCATION IN USER INTERFACE

*Context Menus*

**Brinkman Equations > Porous Medium**

*Ribbon*

Physics tab with **Brinkman Equations** selected:

**Domains > Porous Medium**

*Fluid*

---

This node defines the material properties of the fluid of the [Porous Medium](#) parent node.

### MODEL INPUT

This section contains fields and values that are inputs for expressions defining material properties. If such user-defined property groups are added, the model inputs appear here.

### FLUID PROPERTIES

Specify the **Density**  $\rho$  and the **Dynamic viscosity**  $\mu$  (SI unit: Pa·s) of the fluid. The defaults use values **From material**, for **User defined** enter a value or expression.

The dynamic viscosity describes the relationship between the shear stresses and the shear rate in a fluid. Intuitively, water and air have a low viscosity, and substances often described as thick, such as oil, have a higher viscosity.

If the Polymer Flow Module license is available and for Darcian flow, also non-Newtonian models are available and the **Constitutive Relation** can be switched between **Specify dynamic viscosity** (default) or **Inelastic non-Newtonian**.

*Constitutive Relation*

Use the default option to either get the dynamic viscosity from a material, or to add a user defined expression. The default option lets you either use the dynamic viscosity from a material or define it with a custom expression. The **Inelastic non-Newtonian** option provides several models and defines the **Apparent shear rate**.

*Inelastic Non-Newtonian*

The following inelastic non-Newtonian Models are available for the **Fluid** feature under the **Porous Medium** feature:

- Power Law

- Carreau
- Carreau–Yasuda
- Cross
- Cross–Williamson
- Sisko

The setup of these models in porous media is similar to their definition under the [Fluid Properties](#) feature.

#### *Apparent Shear Rate*

To define the apparent shear rate  $\dot{\gamma}_{app}$ , either enter a user-defined expression for the correction factor ( $\alpha$ ) or choose the **Capillary bundle approach** from the list and provide a value for the Tortuosity factor ( $C$ ).



- Read more about the theory of [Non-Newtonian Fluids in Porous Media](#) in the *Polymer Flow Module User's Guide*

#### **LOCATION IN USER INTERFACE**

A default **Fluid** node is automatically added to the [Porous Medium](#) node.

#### *Context Menus*

**Brinkman Equations > Porous Medium > Fluid**

#### *Porous Matrix*

This node defines the porosity and material properties of the solid matrix of the [Porous Medium](#) parent node.

#### **MODEL INPUT**

This section contains fields and values that are inputs for expressions defining material properties. If such user-defined property groups are added, the model inputs appear here.

#### **MATRIX PROPERTIES**

The **Porosity**  $\varepsilon_p$  (a dimensionless number between 0 and 1) uses by default the value **From material**. For **User defined** the default value is 1.

Select a **Permeability model** to specify the capacity of the porous material to transmit flow. Depending on the **Flow model** selection in the parent **Porous Medium** feature node you can choose between the following options:

- **Permeability** (the default) to directly enter the permeability of the porous matrix or **Kozeny–Carman** to define the permeability from the porosity and mean **Particle diameter** for **Darcian** flow or
- **Forchheimer**, **Ergun**, or **User defined** for **Non-Darcian** flow.

Note that some of these options are only available for certain modules. For a detailed overview of the functionality available in each product, visit [www.comsol.com/products/specifications/](http://www.comsol.com/products/specifications/).

The default **Permeability**  $\kappa$  (SI unit:  $\text{m}^2$ ) uses the value **From material**, as defined by the **Porous material** list. For **User defined** select **Isotropic** to define a scalar value or **Diagonal** or **Symmetric** to define a tensor value.

For **Kozeny–Carman**, enter the mean **Particle diameter**  $d_p$  (SI unit: m), the default value is 0.5 mm.

In case a **Non-Darcian** flow model is chosen in the parent node, **Forchheimer** is the default selection for the **Permeability model**. For **Forchheimer**, the default **Permeability**  $\kappa$  (SI unit:  $\text{m}^2$ ) uses the value **From material**. Furthermore, the dimensionless **Forchheimer parameter**  $c_F$  can be defined. The default value is 0.55.

If **Ergun** is selected, enter the mean **Particle diameter**  $d_p$  (default value: 0.5 mm). The permeability  $\kappa$  is then calculated using [Equation 2-4](#) in the *Porous Media Flow Module User's Guide*.

For the option **User defined** the default **Permeability** uses the option **From material**. Furthermore, the **Inertial resistance coefficient**  $\beta$  (SI unit:  $1/\text{m}$ ) can be defined. Its default value is 0.0.



- [About Darcian and Non-Darcian Flow](#) in the *Porous Media Flow Module User's Guide*
  - [Permeability Models](#) in the *Porous Media Flow Module User's Guide*
- 

#### LOCATION IN USER INTERFACE

A default **Porous Matrix** node is automatically added to the **Porous Medium** node.

Context Menus

**Brinkman Equations > Porous Medium > Porous Matrix**

### Mass Source

---

The **Mass Source** node adds a mass source (or mass sink)  $Q_m$  to the right-hand side of the continuity equation: [Equation 5-73](#). This term accounts for mass deposit and/or mass creation in porous domains. The physics interface assumes that the mass exchange occurs at zero velocity.

$$\frac{\partial}{\partial t}(\varepsilon_p \rho) + \nabla \cdot (\rho \mathbf{u}) = Q_m \quad (5-20)$$

#### DOMAIN SELECTION

Only Porous Matrix domains are available.

#### MASS SOURCE

Enter a value or expression for the **Source term**  $Q_{br}$  (SI unit:  $\text{kg}/(\text{m}^3 \cdot \text{s})$ ). The default is  $0 \text{ kg}/(\text{m}^3 \cdot \text{s})$ .

#### LOCATION IN USER INTERFACE

Context Menus

**Brinkman Equations > Mass Source**

Ribbon

Physics tab with **Brinkman Equations** selected:

**Domains > Mass Source**

### Volume Force

---

Use the **Volume Force** node to specify the force  $\mathbf{F}$  on the right-hand side of [Equation 5-74](#). It then acts on each fluid element in the specified domains.

$$\frac{\rho}{\varepsilon_p} \left( \frac{\partial \mathbf{u}}{\partial t} + (\mathbf{u} \cdot \nabla) \frac{\mathbf{u}}{\varepsilon_p} \right) = -\nabla p + \nabla \cdot \left[ \frac{1}{\varepsilon_p} \left\{ \mu (\nabla \mathbf{u} + (\nabla \mathbf{u})^T) - \frac{2}{3} \mu (\nabla \cdot \mathbf{u}) \mathbf{I} \right\} \right] - \left( \kappa^{-1} \mu + \frac{Q_m}{\varepsilon_p^2} \right) \mathbf{u} + \mathbf{F} \quad (5-21)$$

## VOLUME FORCE

Enter the components of **Volume force  $\mathbf{F}$**  (SI unit: N/m<sup>3</sup>).

## LOCATION IN USER INTERFACE

*Context Menus*

**Brinkman Equations > Volume Source**

*Ribbon*

Physics tab with **Brinkman Equations** selected:

**Domains > Volume Source**

## *Initial Values*

---

The **Initial Values** node adds initial values for the velocity field and the pressure that can serve as an initial condition for a transient simulation or as an initial guess for a nonlinear solver.

## INITIAL VALUES

Enter initial values or expressions for the **Velocity field  $\mathbf{u}$**  (SI unit: m/s) and the **Pressure  $p$**  (SI unit: Pa). The default values are 0 m/s and 0 Pa, respectively.

## LOCATION IN USER INTERFACE

*Context Menus*

**Brinkman Equations > Initial Values**

*Ribbon*

Physics tab with **Brinkman Equations** selected:

**Domains > Initial Values**

## *Fluid Properties*

---

The **Fluid Properties** node adds the momentum and continuity equations to solve for free flow in nonporous domains. The node also provides an interface for defining the material properties of the fluid.

## MODEL INPUTS

Fluid properties, such as density and viscosity, can be defined through user inputs, variables, or by selecting a material. For the latter option, additional inputs — for example, temperature or pressure — may be required to define these properties.

### *Temperature*

By default, the single-phase flow interfaces are set to model isothermal flow. Hence, the **Temperature** is **User defined** and defaults to 293.15 K. If a Heat Transfer interface is included in the component, the temperature may alternatively be selected from this physics interface. All physics interfaces have their own tags (**Name**). For example, if a Heat Transfer in Fluids interface is included in the component, the **Temperature (ht)** option is available.

### *Absolute Pressure*

This input appears when a material requires the absolute pressure as a model input. The absolute pressure is used to evaluate material properties, but it also relates to the value of the calculated pressure field. There are generally two ways to calculate the pressure when describing fluid flow: either to solve for the absolute pressure or for a pressure (often denoted gauge pressure) that relates to the absolute pressure through a reference pressure.

The choice of pressure variable depends on the system of equations being solved. For example, in a unidirectional incompressible flow problem, the pressure drop over the modeled domain is probably many orders of magnitude smaller than the atmospheric pressure, which, when included, may reduce the stability and convergence properties of the solver. In other cases, such as when the pressure is part of an expression for the gas volume or the diffusion coefficients, it may be more convenient to solve for the absolute pressure.

The default **Absolute pressure**  $p_A$  is  $p + p_{\text{ref}}$  where  $p$  is the dependent pressure variable from the Navier–Stokes equations, and  $p_{\text{ref}}$  is from the user input defined at the physics interface level. When  $p_{\text{ref}}$  is nonzero, the physics interface solves for a gauge pressure. If the pressure field instead is an absolute pressure field,  $p_{\text{ref}}$  should be set to 0.

The **Absolute pressure** field can be edited by clicking **Make All Model Inputs Editable** (  ) and entering the desired value in the input field.

## FLUID PROPERTIES

If density variations with respect to pressure are to be included in the computations, the flow must be set to compressible.

The **Dynamic viscosity**  $\mu$  describes the relationship between the shear rate and the shear stresses in a fluid. Intuitively, water and air have low viscosities, and substances often described as thick (such as oil) have higher viscosities.

#### LOCATION IN USER INTERFACE

*Context Menus*

**Brinkman Equations > Fluid Properties**

*Ribbon*

Physics tab with **Brinkman Equations** selected:

**Domains > Fluid Properties**

#### *Gravity*

---

The **Gravity** global feature is automatically added when **Include gravity** is selected at the interface level in the **Physical Model** settings. It defines the gravity forces from the **Acceleration of gravity** value.

This feature requires a specific license. For a detailed overview of the functionality available in each product visit [www.comsol.com/products/specifications/](http://www.comsol.com/products/specifications/).

#### ACCELERATION OF GRAVITY

The **Acceleration of gravity** (SI unit m/s, default value  $-g_{\text{const}}\mathbf{e}_z$  in 2D axial symmetry and 3D and  $-g_{\text{const}}\mathbf{e}_y$  in 2D) is used to define the gravity forces. It should be a global quantity.

When in addition to **Include gravity** also **Rotating frame** is selected (only possible in 3D and 2D axial symmetry), the **Project gravity vector on rotation axis** checkbox is available (by default selected).

#### LOCATION IN USER INTERFACE

*Context Menus*

**Brinkman Equations > Gravity**

#### *Rotating Frame*

---

The **Rotating Frame** global feature is automatically added when **Rotating frame** is selected at the interface level in the **Physical Model** settings. It defines the fictitious Coriolis, centrifugal, and Euler forces from the settings in the **Rotating Frame** section.

This feature requires a specific license. For a detailed overview of the functionality available in each product visit [www.comsol.com/products/specifications/](http://www.comsol.com/products/specifications/).

### ROTATING FRAME

In 2D, the axis of rotation is an out-of-plane axis. In this case, select a **Rotation axis base point**  $\mathbf{r}_{bp}$ .

In 2D axial symmetry, the axis of rotation is the symmetry axis.

In 3D, select an **Axis of rotation** — **x-axis**, **y-axis**, **z-axis** (the default), or **User defined**. For **User defined** enter a **Rotation axis direction**  $\mathbf{e}_{ax}$  and a **Rotation axis base point**  $\mathbf{r}_{bp}$ .

Select a **Rotation speed** — **Angular velocity**, **Revolutions per time**, or **User defined**.

- For **Angular velocity**, enter a value for the angular velocity magnitude  $\Omega_f$ .
- For **Revolutions per time**, enter an RPM value.
- For **User defined**, enter the **Rotation angle**  $\alpha$  in radians as function of time (the variable  $t$ ).

In case **Angular velocity** or **Revolutions per time** is selected, also select a **Rotational direction** — **Counterclockwise** (the default) or **Clockwise**.

### LOCATION IN USER INTERFACE

*Context Menus*

**Brinkman Equations > Rotating Frame**

# Theory for the Laminar Flow and Creeping Flow Interfaces

The theory for the Single-Phase Flow, Laminar Flow interface is described in this section:

- [General Single-Phase Flow Theory](#)
- [Compressible Flow](#)
- [Weakly Compressible Flow](#)
- [The Mach Number Limit](#)
- [Incompressible Flow](#)
- [The Reynolds Number](#)
- [Gravity](#)
- [Rotating Frame](#)
- [Theory for the Wall Boundary Condition](#)
- [Prescribing Inlet and Outlet Conditions](#)
- [Fully Developed Flow \(Inlet\)](#)
- [Fully Developed Flow \(Outlet\)](#)
- [No Viscous Stress](#)
- [Normal Stress Boundary Condition](#)
- [Porous Interface](#)
- [Mass Sources for Fluid Flow](#)
- [Numerical Stability — Stabilization Techniques for Fluid Flow](#)
- [Solvers for Laminar Flow](#)
- [Pseudo Time Stepping for Laminar Flow Models](#)
- [Nitsche Constraints](#)
- [Particle Tracing in Fluid Flow](#)
- [References for the Single-Phase Flow, Laminar Flow Interfaces](#)



The theory about most boundary conditions is found in [Ref. 2](#).

---

## General Single-Phase Flow Theory

---

The Single-Phase Fluid Flow interfaces are based on the Navier–Stokes equations, which in their most general form read

$$\frac{\partial \rho}{\partial t} + \nabla \cdot (\rho \mathbf{u}) = 0 \quad (5-22)$$

$$\rho \frac{\partial \mathbf{u}}{\partial t} + \rho (\mathbf{u} \cdot \nabla) \mathbf{u} = \nabla \cdot [-p \mathbf{I} + \mathbf{K}] + \mathbf{F} \quad (5-23)$$

$$\rho C_p \left( \frac{\partial T}{\partial t} + (\mathbf{u} \cdot \nabla) T \right) = -(\nabla \cdot \mathbf{q}) + \mathbf{K} : \mathbf{S} - \frac{T}{\rho} \frac{\partial \rho}{\partial T} \bigg|_p \left( \frac{\partial p}{\partial t} + (\mathbf{u} \cdot \nabla) p \right) + Q \quad (5-24)$$

where

- $\rho$  is the density (SI unit: kg/m<sup>3</sup>)
- $\mathbf{u}$  is the velocity vector (SI unit: m/s)
- $p$  is pressure (SI unit: Pa)
- $\mathbf{I}$  is the identity matrix (unitless)
- $\mathbf{K}$  is the viscous stress tensor (SI unit: Pa)
- $\mathbf{F}$  is the volume force vector (SI unit: N/m<sup>3</sup>)
- $C_p$  is the specific heat capacity at constant pressure (SI unit: J/(kg·K))
- $T$  is the absolute temperature (SI unit: K)
- $\mathbf{q}$  is the heat flux vector (SI unit: W/m<sup>2</sup>)
- $Q$  contains the heat sources (SI unit: W/m<sup>3</sup>)
- $\mathbf{S}$  is the strain-rate tensor:

$$\mathbf{S} = \frac{1}{2} (\nabla \mathbf{u} + (\nabla \mathbf{u})^T)$$

The operation “:” denotes a contraction between tensors defined by

$$\mathbf{a} : \mathbf{b} = \sum_n \sum_m a_{nm} b_{nm} \quad (5-25)$$

This is sometimes referred to as the double dot product.

Equation 5-22 is the continuity equation and represents conservation of mass.

Equation 5-23 is a vector equation which represents conservation of momentum.

Equation 5-24 describes the conservation of energy, formulated in terms of temperature. This is an intuitive formulation that facilitates boundary condition specifications.

To close the equation system, Equation 5-22 through Equation 5-24, constitutive relations are needed.

For a Newtonian fluid, which has a linear relationship between stress and strain, Stokes (Ref. 1) deduced the following expression:

$$\mathbf{K} = 2\mu\mathbf{S} - \frac{2}{3}\mu(\nabla \cdot \mathbf{u})\mathbf{I} \quad (5-26)$$

The dynamic viscosity,  $\mu$  (SI unit: Pa·s), for a Newtonian fluid is allowed to depend on the thermodynamic state but not on the velocity field. All gases and many liquids can be considered Newtonian.

For an inelastic non-Newtonian fluid, the relationship between stress and strain rate is nonlinear, and an apparent viscosity is introduced instead of the dynamic viscosity. Examples of non-Newtonian fluids are honey, mud, blood, liquid metals, and most polymer solutions.

In theory, the same equations describe both laminar and turbulent flows. In practice, however, the mesh resolution required to simulate turbulence with the Laminar Flow interface makes such an approach impractical.



---

There are several books where derivations of the Navier–Stokes equations and detailed explanations of concepts such as Newtonian fluids can be found. See, for example, the classical text by Batchelor (Ref. 3) and the more recent work by Panton (Ref. 4).

---

Many applications describe isothermal flows for which Equation 5-24 is decoupled from Equation 5-22 and Equation 5-23.

## 2D AXISYMMETRIC FORMULATIONS

A 2D axisymmetric formulation of Equation 5-22 and Equation 5-23 requires  $\partial/\partial\phi$  to be zero. That is, there must be no gradients in the azimuthal direction. A common additional assumption is, however, that  $u_\phi = 0$ . In such cases, the  $\phi$ -equation can be removed from Equation 5-23. The resulting system of equations is both easier to converge and computationally less expensive compared to retaining the  $\phi$ -equation.

The default 2D axisymmetric formulation of [Equation 5-22](#) and [Equation 5-23](#) therefore assumes that

$$\begin{aligned}\partial/\partial\phi &= 0 \\ u_\phi &= 0\end{aligned}$$

### *Compressible Flow*

---

The equations of motion for a single-phase fluid are the continuity equation:

$$\frac{\partial\rho}{\partial t} + \nabla \cdot (\rho\mathbf{u}) = 0 \quad (5-27)$$

and the momentum equation:

$$\rho\frac{\partial\mathbf{u}}{\partial t} + \rho\mathbf{u} \cdot \nabla\mathbf{u} = -\nabla p + \nabla \cdot \left( \mu(\nabla\mathbf{u} + (\nabla\mathbf{u})^T) - \frac{2}{3}\mu(\nabla \cdot \mathbf{u})\mathbf{I} \right) + \mathbf{F} \quad (5-28)$$

These equations are applicable for incompressible as well as for compressible flow with density and viscosity variations.

### *Weakly Compressible Flow*

---

The same equations as for [Compressible Flow](#) are applied for weakly compressible flow. The only difference is that the density is evaluated at the reference pressure. The density may be a function of other quantities, in particular it may be temperature dependent.

The weakly compressible flow equations are valid for incompressible as well as compressible flow with density variations independent of the pressure.

Provided that the densities dependency pressure is specified through model inputs, the density is automatically evaluated at the reference pressure level.

### *The Mach Number Limit*

---

An important dimensionless number in fluid dynamics is the Mach number,  $\text{Ma}$ , defined by

$$\text{Ma} = \frac{|\mathbf{u}|}{a}$$

where  $a$  is the speed of sound. A flow is formally incompressible when  $Ma = 0$ . This is theoretically achieved by letting the speed of sound tend to infinity. The Navier–Stokes equations then have the mathematical property that pressure disturbances are instantaneously propagated throughout the entire domain. This results in a parabolic equation system.

The momentum equation, Equation 5-28, is parabolic for unsteady flow and elliptic for steady flow, whereas the continuity equation, Equation 5-27, is hyperbolic for both steady and unsteady flow. The combined system of equations is thus hybrid parabolic-hyperbolic for unsteady flow and hybrid elliptic-hyperbolic for steady flow. An exception occurs when the viscous term in Equation 5-28 becomes vanishingly small, such as at an outflow boundary, in which case the momentum equation becomes locally hyperbolic. The number of boundary conditions to apply on the boundary then depends on the number of characteristics propagating into the computational domain. For the purely hyperbolic system, the number of characteristics propagating from the boundary into the domain changes as the Mach number passes through unity. Hence, the number of boundary conditions required to obtain a numerically well-posed system must also change. The compressible formulation of the laminar and turbulent interfaces uses the same boundary conditions as the incompressible formulation, which implies that the compressible interfaces are not suitable for flows with a Mach number larger than or equal to one. Yet, the practical Mach number limit is lower than one. The main reason is that the numerical scheme (stabilization and boundary conditions) of the Laminar Flow interface does not recognize the direction and speed of pressure waves. The fully compressible Navier–Stokes equations do, for example, start to display very sharp gradients already at moderate Mach numbers. But the stabilization for the single-phase flow interface does not necessarily capture these gradients. It is impossible to give an exact limit where the low Mach number regime ends and the moderate Mach number regime begins, but a rule of thumb is that the Mach number effects start to appear at  $Ma = 0.3$ . For this reason, the compressible formulation is referred to as *Compressible flow* ( $Ma < 0.3$ ) in COMSOL Multiphysics.

### *Incompressible Flow*

---

When the temperature variations in the flow are small, a single-phase fluid can often be assumed incompressible; that is,  $\rho$  is constant or nearly constant. This is the case for all liquids under normal conditions and also for gases at low velocities. For constant  $\rho$ , Equation 5-27 reduces to

$$\rho \nabla \cdot \mathbf{u} = 0 \quad (5-29)$$

and Equation 5-28 becomes

$$\rho \frac{\partial \mathbf{u}}{\partial t} + \rho(\mathbf{u} \cdot \nabla) \mathbf{u} = \nabla \cdot [-p \mathbf{I} + \mu(\nabla \mathbf{u} + (\nabla \mathbf{u})^T)] + \mathbf{F} \quad (5-30)$$

Provided that the densities dependency on temperature and pressure is specified through model inputs, the density is evaluated at the reference pressure level and at the reference temperature. However, if the density is a function of other quantities such as a concentration field, or if the density is specified by a user defined expression, the user has to make sure that the density is defined as constant when the incompressible flow formulation is used.

### *The Reynolds Number*

---

A fundamental characteristic in analyses of fluid flow is the Reynolds number:

$$\text{Re} = \frac{\rho U L}{\mu}$$

where  $U$  denotes a velocity scale, and  $L$  denotes a representative length. The Reynolds number represents the ratio between inertial and viscous forces. At low Reynolds numbers, viscous forces dominate and tend to damp out all disturbances, which leads to laminar flow. At high Reynolds numbers, the damping in the system is very low, giving small disturbances the possibility to grow by nonlinear interactions. If the Reynolds number is high enough, the flow field eventually ends up in a chaotic state called turbulence.

Note that the Reynolds number can have different meanings depending on the length scale and velocity scale. To be able to compare two Reynolds numbers, they must be based on equivalent length and velocity scales.

The Fluid Flow interfaces automatically calculate the local cell Reynolds number  $\text{Re}^c = \rho |\mathbf{u}| h / (2\mu)$  using the element length  $h$  for  $L$  and the magnitude of the velocity vector  $\mathbf{u}$  for the velocity scale  $U$ . This Reynolds number is not related to the character of the flow field, but to the stability of the numerical discretization. The risk for numerical oscillations in the solution increases as  $\text{Re}^c$  grows. The cell Reynolds number is a predefined quantity available for visualization and evaluation (typically it is available as: `spf.cellRe`).

**DEFINITION**

The gravity force is defined from the acceleration of gravity vector,  $\mathbf{g}$ , and the density,  $\rho$ . Under usual conditions and in Cartesian coordinates with the  $z$ -axis in the vertical direction,

$$\mathbf{g} = \begin{pmatrix} 0 \\ 0 \\ -\mathbf{g}_{\text{const}} \end{pmatrix}.$$

When gravity is considered, a volume force equal to  $\rho\mathbf{g}$  is included in the momentum equation. For example, for laminar weakly compressible flow, it reads:

$$\rho \frac{\partial \mathbf{u}}{\partial t} + \rho \mathbf{u} \cdot \nabla \mathbf{u} = \nabla \cdot \left( -p \mathbf{I} + \mu (\nabla \mathbf{u} + (\nabla \mathbf{u})^T) - \frac{2}{3} \mu (\nabla \cdot \mathbf{u}) \mathbf{I} \right) + \mathbf{F} + \rho \mathbf{g} \quad (5-31)$$

Introducing a constant reference density  $\rho_{\text{ref}}$ , and assuming that  $\mathbf{g}$  is homogeneous, this equation is equivalently written:

$$\begin{aligned} \rho \frac{\partial \mathbf{u}}{\partial t} + \rho \mathbf{u} \cdot \nabla \mathbf{u} = & \\ \nabla \cdot \left( -p \mathbf{I} + \mu (\nabla \mathbf{u} + (\nabla \mathbf{u})^T) - \frac{2}{3} \mu (\nabla \cdot \mathbf{u}) \mathbf{I} + \rho_{\text{ref}} \mathbf{g} \cdot (\mathbf{r} - \mathbf{r}_{\text{ref}}) \right) + \mathbf{F} + (\rho - \rho_{\text{ref}}) \mathbf{g} & \end{aligned} \quad (5-32)$$

where  $\mathbf{r}$  is the position vector and  $\mathbf{r}_{\text{ref}}$  is an arbitrary reference position vector.

From this equation, it is convenient to define the reduced pressure which accounts for the hydrostatic pressure,  $\tilde{p} = p - \rho_{\text{ref}} \mathbf{g} \cdot (\mathbf{r} - \mathbf{r}_{\text{ref}})$

$$\begin{aligned} \rho \frac{\partial \mathbf{u}}{\partial t} + \rho \mathbf{u} \cdot \nabla \mathbf{u} = \nabla \cdot \left( -\tilde{p} \mathbf{I} + \mu (\nabla \mathbf{u} + (\nabla \mathbf{u})^T) - \frac{2}{3} \mu (\nabla \cdot \mathbf{u}) \mathbf{I} \right) + & \\ \mathbf{F} + (\rho - \rho_{\text{ref}}) \mathbf{g} & \end{aligned} \quad (5-33)$$

In Equation 5-33, the gravity force is written  $(\rho - \rho_{\text{ref}}) \mathbf{g}$ .

**PRESSURE FORMULATION**

When the relative pressure is used (default option) the interface dependent variable represents the relative pressure and the absolute pressure is defined as  $p_A = p_{\text{ref}} + p$ . When the pressure is used to define a boundary condition (for example, when  $p_0$

defines the pressure condition at an outlet), it represents the relative pressure. Hence defining the outlet pressure as  $p_{\text{hydro,approx}} = -\rho_{\text{ref}}\mathbf{g} \cdot (\mathbf{r} - \mathbf{r}_{\text{ref}})$  compensates for the gravity force for an ambient reference pressure of 0 Pa when the density is constant, there is no external force, and provided  $p_{\text{ref}}$ ,  $\mathbf{g}$ , and  $\mathbf{r}_0$  are defined consistently.

When the reduced pressure is used, the interface dependent variable (named  $p$  by default) represents the reduced pressure. The absolute pressure is then defined as  $p_A = p_{\text{ref}} - \rho_{\text{ref}}\mathbf{g} \cdot (\mathbf{r} - \mathbf{r}_{\text{ref}}) + p$ . In this case when the pressure is used to define a boundary condition (for example, to define a pressure condition at an outlet), its value corresponds to the reduced pressure. Hence, the prescribed pressure compensates for an approximate hydrostatic pressure,  $p_{\text{hydro,approx}} = -\rho_{\text{ref}}\mathbf{g} \cdot (\mathbf{r} - \mathbf{r}_{\text{ref}})$ , which is exact only when the density is constant and there is no external force.

### PRESSURE BOUNDARY CONDITION

For an immobile fluid the momentum equation simplifies to  $\nabla \cdot (p\mathbf{I}) = \mathbf{F} + \rho\mathbf{g}$  or

$$\nabla \cdot (-\tilde{p}\mathbf{I}) = \mathbf{F} + (\rho - \rho_{\text{ref}})\mathbf{g} \text{ depending on the pressure formulation.}$$

For incompressible flow, assuming there are no external forces, this leads respectively to  $p = -\rho_{\text{ref}}\mathbf{g} \cdot (\mathbf{r} - \mathbf{r}_{\text{ref}}) + p_0$  or  $\tilde{p} = p_0$ .

### *Rotating Frame*

---

The fictitious Coriolis, centrifugal and Euler forces, present in a rotating frame of reference, are stemming from the change to a non-inertial frame of reference, and are defined using the vector of angular velocity,  $\Omega_f$ , and the density,  $\rho$ . This amounts to adding to the momentum equation a volume force equal to

$$\mathbf{F}_{\text{ff}} = -\rho \left( \Omega_f \times (\Omega_f \times \mathbf{r}_p) + 2\Omega_f \times \mathbf{u} + \frac{\partial \Omega_f}{\partial t} \times \mathbf{r}_p \right) \quad (5-34)$$

where  $\mathbf{r}_p = \mathbf{r} - \mathbf{r}_{\text{bp}}$ , with  $\mathbf{r}_{\text{bp}}$  a position vector on the axis of rotation. The first term on the right-hand side is the centrifugal force, the second term the Coriolis force, and the third term the Euler force. With these forces, the momentum equation reads:

$$\rho \frac{\partial \mathbf{u}}{\partial t} + \rho \mathbf{u} \cdot \nabla \mathbf{u} = \nabla \cdot (-p\mathbf{I} + \mathbf{K}) - \rho \left( \Omega_f \times (\Omega_f \times \mathbf{r}_p) + 2\Omega_f \times \mathbf{u} + \frac{\partial \Omega_f}{\partial t} \times \mathbf{r}_p \right) \quad (5-35)$$

Introducing a constant reference density  $\rho_{\text{ref}}$ , this equation is equivalently written:

$$\begin{aligned} \rho \frac{\partial \mathbf{u}}{\partial t} + \rho \mathbf{u} \cdot \nabla \mathbf{u} = \nabla \cdot \left( -p \mathbf{I} + \mathbf{K} + \frac{1}{2} \rho_{\text{ref}} (|\boldsymbol{\Omega}_f \times \mathbf{r}_p|^2 - |\boldsymbol{\Omega}_f \times (\mathbf{r}_{\text{ref}} - \mathbf{r}_{\text{bp}})|^2) \mathbf{I} \right) \\ - (\rho - \rho_{\text{ref}}) (\boldsymbol{\Omega}_f \times (\boldsymbol{\Omega}_f \times \mathbf{r}_p)) + \rho \left( 2 \boldsymbol{\Omega}_f \times \mathbf{u} + \frac{\partial \boldsymbol{\Omega}_f}{\partial t} \times \mathbf{r}_p \right) \end{aligned} \quad (5-36)$$

where  $\mathbf{r}$  is the position vector and  $\mathbf{r}_{\text{ref}}$  is an arbitrary reference position vector. From this equation, it is convenient to define the reduced pressure which accounts for the hydrostatic pressure stemming from the centrifugal force as

$$\tilde{p} = p - \frac{1}{2} \rho_{\text{ref}} (|\boldsymbol{\Omega}_f \times \mathbf{r}_p|^2 - |\boldsymbol{\Omega}_f \times (\mathbf{r}_{\text{ref}} - \mathbf{r}_{\text{bp}})|^2) \quad (5-37)$$

When the relative pressure formulation is used, also the hydrostatic pressure,  $p_{\text{hydro}} = \frac{1}{2} \rho_{\text{ref}} (|\boldsymbol{\Omega}_f \times \mathbf{r}_p|^2 - |\boldsymbol{\Omega}_f \times (\mathbf{r}_{\text{ref}} - \mathbf{r}_{\text{bp}})|^2)$ , stemming from the centrifugal force, is taken into account when compensating for the hydrostatic pressure at a pressure boundary conditions. When a reduced pressure formulation is used,  $p_{\text{hydro}}$  is used to define the absolute pressure, see also the section on [Gravity](#).

### CORIOLIS FORCE IN POROUS DOMAINS

In a porous domain, the Coriolis force should be divided by the porosity  $\varepsilon_p$ , such that the volume force added to the momentum equation becomes

$$\mathbf{F}_{\text{rf}} = -\rho \left( \boldsymbol{\Omega}_f \times (\boldsymbol{\Omega}_f \times \mathbf{r}_p) + \frac{2}{\varepsilon_p} \boldsymbol{\Omega}_f \times \mathbf{u} + \frac{\partial \boldsymbol{\Omega}_f}{\partial t} \times \mathbf{r}_p \right) \quad (5-38)$$

### *Theory for the Wall Boundary Condition*

---

See [Wall](#) for the node settings.

#### SLIP

The [Slip](#) condition assumes that there are no viscous effects at the slip wall and hence, no boundary layer develops. From a modeling point of view, this is a reasonable approximation if the important effect of the wall is to prevent fluid from leaving the domain. Mathematically, the constraint can be formulated as:

$$\mathbf{u} \cdot \mathbf{n} = 0, \quad (-p \mathbf{I} + \mu (\nabla \mathbf{u} + (\nabla \mathbf{u})^T)) \mathbf{n} = \mathbf{0}$$

The no-penetration term takes precedence over the Neumann part of the condition and the above expression is therefore equivalent to

$$\mathbf{u} \cdot \mathbf{n} = 0, \quad \mathbf{K}_n - (\mathbf{K}_n \cdot \mathbf{n})\mathbf{n} = \mathbf{0}$$

$$\mathbf{K}_n = \mu(\nabla \mathbf{u} + (\nabla \mathbf{u})^T)\mathbf{n}$$

expressing that there is no flow across the boundary and no viscous stress in the tangential direction.

For a moving wall with translational velocity  $\mathbf{u}_{\text{tr}}$ ,  $\mathbf{u}$  in the above equations is replaced by the relative velocity  $\mathbf{u}_{\text{rel}} = \mathbf{u} - \mathbf{u}_{\text{tr}}$ .

### POROUS SLIP

The **Porous slip** option, which can be chosen in the **Porous treatment of no slip condition** list when **Enable porous media domains** is activated, results in a special treatment of **Wall** boundaries and **Interior Wall** boundaries adjacent to porous domains (**Porous Medium** feature). Namely, similar to the **Navier slip** boundary condition, no penetration and tangential stress conditions are applied at the wall:

$$\mathbf{u} \cdot \mathbf{n} = 0, \quad \mathbf{K}_n - (\mathbf{K}_n \cdot \mathbf{n})\mathbf{n} = -\frac{\mu}{\varepsilon_p} \frac{\mathbf{u}_{\text{slip}}}{y_{\text{ps}}},$$

$$\mathbf{u}_{\text{slip}} = \mathbf{u} - (\mathbf{u} \cdot \mathbf{n})\mathbf{n}, \quad \mathbf{K}_n = \frac{\mu}{\varepsilon_p} (\nabla \mathbf{u} + (\nabla \mathbf{u})^T)\mathbf{n}$$

Here,  $\mathbf{K}_n$  is the viscous wall traction,  $\mathbf{n}$  is the wall normal,  $\mathbf{u}_{\text{slip}}$  is the tangential velocity at the wall while real no slip is assumed to be applied at a distance  $d_w$  (half-height of the first cell adjacent to the wall) outside the wall, and  $y_{\text{ps}}$  is the porous slip length. An analytical derivation of the velocity profile in the boundary layer where the pressure gradient is balanced by the sum of the Darcy term, the Forchheimer drag, and the viscous term (neglecting convective terms) leads to the following expression for  $y_{\text{ps}}$ :

$$y_{\text{ps}} = \tilde{l} \left( \frac{1 + X_p e^{-\xi_p}}{1 - X_p e^{-\xi_p}} \right) \left[ \left( \frac{1 + X_p e^{-\xi_p}}{1 + X_p} \right)^2 e^{\xi_p} - 1 \right], \quad \xi_p = \frac{d_w}{\tilde{l}}, \quad \tilde{l} = \frac{l_{\text{pore}}}{\sqrt{1 + 2c_\beta}},$$

$$X_p = \frac{\sqrt{1 + 2c_\beta} - \sqrt{1 + \frac{4}{3}c_\beta}}{\sqrt{1 + 2c_\beta} + \sqrt{1 + \frac{4}{3}c_\beta}}, \quad c_\beta = \frac{\sqrt{1 + 4c_D} - 1}{2}, \quad c_D = \frac{\beta_{\text{ND}}}{\mu} \frac{\kappa^2}{\mu} |\nabla p - \rho \mathbf{g}|$$

where  $l_{\text{pore}} = \sqrt{\kappa/\varepsilon_p}$  is the porous length scale,  $\beta_{\text{ND}} = \rho c_F/\sqrt{\kappa}$  is the non-Darcian coefficient ( $c_F$  is the Forchheimer coefficient),  $\mathbf{g}$  is the gravity vector, and  $\xi_p, l, X_p, c_\beta, c_D$ , are intermediate variables. This formula is used when the **Pressure-gradient**

**formulation** is chosen and it uses the pressure gradient at the wall. By default, the **Velocity formulation** is activated and the corresponding formula is:

$$y_{ps} = \tilde{l} (e^{\xi_p} - 1), \quad \xi_p = \frac{d_w}{\tilde{l}}, \quad \tilde{l} = \frac{l_{\text{pore}}}{\sqrt{1 + 2c_\beta}},$$

$$c_\beta = \left[ \left( \frac{\beta_{\text{ND}} \kappa |\mathbf{u}_{\text{slip}}|}{\mu} \frac{l_{\text{pore}}}{d_w} \right)^2 / 2 \right]^{1/3}$$

Although this formulation is an approximation, since it uses the slip velocity at the wall to reconstruct the pressure gradient, it is rather accurate. Moreover, the influence of the convective terms is partially accounted for in this formulation.

### SLIDING WALL

The sliding wall option is appropriate if the wall behaves like a conveyor belt; that is, the surface is sliding in its tangential direction. The wall does not have to actually move in the coordinate system.

- In 2D, the tangential direction is unambiguously defined by the direction of the boundary, but the situation becomes more complicated in 3D. For this reason, this boundary condition has slightly different definitions in the different space dimensions.
- For 2D and 2D axisymmetric components, the velocity is given as a scalar  $U_w$  and the condition prescribes

$$\mathbf{u} \cdot \mathbf{n} = 0, \quad \mathbf{u} \cdot \mathbf{t} = U_w$$

where  $\mathbf{t} = (n_y, -n_x)$  for 2D and  $\mathbf{t} = (n_z, -n_r)$  for axial symmetry.

- For 3D components, the velocity is set equal to a given vector  $\mathbf{u}_w$  projected onto the boundary plane:

$$\mathbf{u} = \frac{\mathbf{u}_w - (\mathbf{n} \cdot \mathbf{u}_w) \mathbf{n}}{\|\mathbf{u}_w - (\mathbf{n} \cdot \mathbf{u}_w) \mathbf{n}\|} \|\mathbf{u}_w\|$$

The normalization makes  $\mathbf{u}$  have the same magnitude as  $\mathbf{u}_w$  even if  $\mathbf{u}_w$  is not exactly parallel to the wall.

## CONSTRAINT SETTINGS

The wall feature uses three different techniques to constrain the velocity field:

- **Pointwise constraints** is the standard technique to enforce strong constraints in the finite element method. The desired value of the velocity is prescribed at each node point in the mesh. Since the constraint is enforced locally at each node, only local values are affected by the constraint and the constraints are independent of each other. The solvers can therefore eliminate both the constrained degrees of freedom and the constraint force terms, effectively reducing the number of degrees of freedom being solved for.

The main advantage of pointwise constraints is that they enforce the constraint exactly pointwise. This means that they do not introduce any leakage of the velocity across the wall, unless specified. The main disadvantage of pointwise constraints is that they introduce locking effects when trying to impose a no-penetration condition for the velocity,  $\mathbf{u} \cdot \mathbf{n} = 0$ , on curved walls or walls with sharp corners.

- **Weak constraints** is an alternative method to prescribe the velocity. It consists on enforcing the boundary condition for the velocity via *Lagrange multipliers*. Their main advantage is that the Lagrange multiplier can provide an accurate representation of the reaction flux at the wall. Their main disadvantage is that they introduce extra unknowns, and are usually difficult to combine with other constraint methods on adjacent boundaries. Moreover, they may require extra constraints for the Lagrange multipliers. For more information, see [Weak Constraints](#) in the *COMSOL Multiphysics Reference Manual*.
- **Nitsche constraints** use a numerical flux to prescribe the velocity at the wall. They impose the constraint in an integral sense rather than pointwise, and do not suffer from the locking effects introduced by pointwise constraints when trying to prescribe a no penetration condition for the velocity. They are also better behaved when prescribing nonlinear constraints. Their main disadvantage is that the constraint is only imposed approximately, and may produce small leaks. For more information, see [Nitsche Constraints](#).

The following combination of Constraint techniques can be selected in the **Constraint Setting** sections of Wall boundary conditions:

- **Automatic** (default) use different constraint methods depending on whether only the normal component of the velocity is prescribed, such as in the no penetration condition,  $\mathbf{u} \cdot \mathbf{n} = 0$ , imposed, for example, in Slip walls or No Slip walls using Wall

Functions or Automatic Wall Treatment, or both tangential and normal components are prescribed, as is the case of No Slip walls in laminar flow.

Nitsche constraints are used to impose the no penetration condition for Slip walls. When a No Slip condition is prescribed, pointwise constraints are used except for moving walls where Nitsche constraints are used.

- **Pointwise constraints**
- **Nitsche constraints**
- **Weak constraints** — these are not available on Interior Walls.
- **Mixed constraints** — this option is only available when both the tangential and normal components of the velocity need to be prescribed. The velocity on the wall normal direction is imposed via pointwise constraints. The constraint for the tangential directions is relaxed, and Nitsche constraints are used instead. This provides improved accuracy and performance when working with coarse boundary layer meshes. For more information, see [Ref. 18](#).

### *Prescribing Inlet and Outlet Conditions*

---

The Navier–Stokes equations can show large variations in mathematical behavior, ranging from almost completely elliptic to almost completely hyperbolic. This has implications when it comes to prescribing admissible boundary conditions. There is also a discrepancy between mathematically valid boundary conditions and practically useful boundary conditions. See [Inlet](#) and [Outlet](#) for the node settings.

#### **INLET CONDITIONS**

An inlet requires specification of the velocity components. The most robust way to do this is to prescribe a velocity field using a Velocity condition.

A common alternative to prescribing the complete velocity field is to prescribe a pressure and all but one velocity component. The pressure cannot be specified pointwise because this is mathematically over-constraining. Instead the pressure can be specified via a stress condition:

$$-p + 2\mu \frac{\partial u_n}{\partial n} = F_n \quad (5-39)$$

where  $\partial u_n / \partial n$  is the normal derivative of the normal velocity component.

[Equation 5-39](#) is prescribed by the Pressure condition in the Inlet and Outlet features and the Normal stress condition in the Open Boundary and Boundary Stress features. [Equation 5-39](#) is mathematically more stringent compared to specifying the pressure

pointwise and at the same time cannot guarantee that  $p$  obtains the desired value. In practice,  $p$  is close to  $F_n$ , except for low Reynolds number flows where viscous effects are the only effects that balance the pressure. In addition to Equation 5-39, all but one velocity component must be specified. For low Reynolds numbers, this can be specified by a vanishing tangential stress condition:

$$\mu \frac{\partial u_t}{\partial n} = 0$$

which is what the Normal stress condition does. Vanishing tangential stress becomes a less well-posed inlet condition as the Reynolds number increases. The Pressure condition in the Inlet feature therefore requires a flow direction to be prescribed, which provides a well-posed condition independent of Reynolds number.

### OUTLET CONDITIONS

The most common approach is to prescribe a pressure via a normal stress condition on the outlet. This is often accompanied by a vanishing tangential stress condition:

$$\mu \frac{\partial u_t}{\partial n} = 0$$

where  $\partial u_t / \partial n$  is the normal derivative of the tangential velocity field. It is also possible to prescribe  $u_t$  to be zero. The latter option should be used with care since it can have a significant effect on the upstream solution.

The elliptic character of the Navier–Stokes equations mathematically permits specifying a complete velocity field at an outlet. This can, however, be difficult to apply in practice. The reason being that it is hard to prescribe the outlet velocity so that it is consistent with the interior solution at each point. The adjustment to the specified velocity then occurs across an outlet boundary layer. The thickness of this boundary layer depends on the Reynolds number; the higher the Reynolds number, the thinner the boundary layer.

### ALTERNATIVE FORMULATIONS

COMSOL Multiphysics provides several specialized boundary conditions that either provide detailed control over the flow at the boundary or that simulate specific devices.

In practice they often prescribe a velocity or a pressure but calculate the prescribed values using, for example, ODEs.



## Normal Stress Boundary Condition

### *Fully Developed Flow (Inlet)*

The **Fully developed flow** boundary condition can be understood from the following figure:

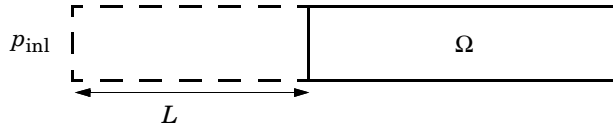

The flow to the domain  $\Omega$  is assumed to enter through a straight channel of length  $L$ . The channel is a virtual extrusion of the inlet cross section and a pressure constant pressure  $P_{inl}$  is applied on the inlet of the virtual channel.

The Fully Developed Flow boundary condition prescribes that the tangential flow component on the boundary is zero:

$$\mathbf{u} - (\mathbf{u} \cdot \mathbf{n})\mathbf{n} = \mathbf{0}$$

The momentum equation for a fully developed flow in the virtual extrusion of the inlet cross section can then be projected onto the inlet boundary with the following weak equation as the result:

$$\int_{\partial\Omega} \left( \left( L \left( -\mu (\nabla_{\mathbf{t}} \mathbf{u} + (\nabla_{\mathbf{t}} \mathbf{u})^T) + \frac{(p + P_{inl})}{2} \mathbf{I} \right) : (\nabla_{\mathbf{t}} \hat{\mathbf{u}}) \right) - P_{inl} (\mathbf{n} \cdot \hat{\mathbf{u}}) \right)$$

The exact value of  $L$  is somewhat arbitrary as long as it is not too high or too low.  $L$  is therefore set to ten times the inlet edge length in 2D and to ten times the square root of the inlet area in 2D axisymmetry and in 3D.

The fact that the velocity profile is not prescribed, but rather the solution of a projected weak contribution, means that the actual velocity profile that is obtained on the inlet can deviate from the analytical fully developed flow profile (in cases such an analytical solution exists) if required by the solution inside the computational domain,  $\Omega$ . This is

most notably if the flow is strongly curved just downstream of the inlet. This can, for example, be the case if an object is positioned just downstream of the inlet or if the adjacent boundaries are not orthogonal to the inlet. The analytical solution can in these cases be recovered by including a little bit of the inlet channel in the computational domain.

The inlet pressure,  $P_{\text{inl}}$ , must be solved for and its equation is a discrete algebraic equation (DAE) for  $P_{\text{inl}}$ . When, for example, the average velocity is specified, the DAE reads

$$(\langle \mathbf{u} \cdot \mathbf{n} \rangle + U_{\text{av}}) \hat{P}_{\text{inl}}$$

where  $\langle \cdot \rangle$  denotes the average over the inlet. Since the equation for  $P_{\text{inl}}$  is a DAE (the equation for  $P_{\text{inl}}$  does not contain  $P_{\text{inl}}$ ), it must be solved coupled to Navier–Stokes and it must be treated by a Vanka presmoothen and postsmoother if iterative solvers are used.

The boundary conditions for the virtual inlet channel are inherited from the boundaries adjacent to the inlet channel. Virtual boundaries adjacent to walls (except slip walls) are treated as no-slip walls. Virtual boundaries adjacent to any other type of boundary are treated as slip-walls (or equivalently as symmetry boundaries). So in the figure above, if the lower boundary of  $\Omega$  is a no-slip wall and the top boundary is a symmetry boundary, the lower boundary of the virtually extruded channel becomes a no-slip wall and the upper boundary becomes a symmetry boundary.

Algebraic turbulence models need additional equations or constraints. For all other turbulence models, their weak equations in the virtual inlet channel are projected onto the inlet of the computational domain. The projections are regularized to prevent the production to fall to zero, so the solutions of the projects can show slight deviation from the correct solutions close to no-slip walls.

### *Fully Developed Flow (Outlet)*

---

The **Fully developed flow** boundary condition can be understood from the following figure:

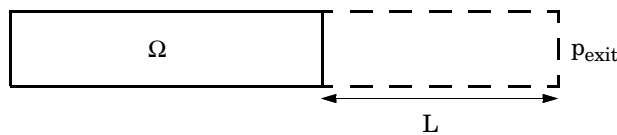

The flow to the domain  $\Omega$  is assumed to enter through a straight channel of length  $L$ . The channel is a virtual extrusion of the inlet cross section and a pressure constant pressure  $P_{\text{exit}}$  is applied on the inlet of the virtual channel.

The Fully Developed Flow boundary condition prescribes that the tangential flow component on the boundary is zero:

$$\mathbf{u} - (\mathbf{u} \cdot \mathbf{n})\mathbf{n} = \mathbf{0}$$

The momentum equation for a fully developed flow in the virtual extrusion of the inlet cross section can then be projected onto the inlet boundary with the following weak equation as the result:

$$\int_{\partial\Omega} \left( L \left( -\mu (\nabla_{\mathbf{t}} \mathbf{u} + (\nabla_{\mathbf{t}} \mathbf{u})^T) + \frac{(p + P_{\text{exit}})}{2} \mathbf{I} \right) : (\nabla_{\mathbf{t}} \hat{\mathbf{u}}) - P_{\text{exit}} (\mathbf{n} \cdot \hat{\mathbf{u}}) \right)$$

The exact value of  $L$  is somewhat arbitrary as long as it is not too high or too low.  $L$  is therefore set to ten times the inlet edge length in 2D and to ten times the square root of the inlet area in 2D axisymmetry and in 3D.

The fact that the velocity profile is not prescribed, but rather the solution of a projected weak contribution, means that the actual velocity profile that is obtained on the outlet can deviate from the analytical fully developed flow profile (in cases such an analytical solution exists) if required by the solution inside the computational domain,  $\Omega$ . The inlet pressure,  $P_{\text{exit}}$ , must be solved for and its equation is a discrete algebraic equation (DAE) for  $P_{\text{exit}}$ . When, for example, the average velocity is specified, the DAE reads

$$(\langle \mathbf{u} \cdot \mathbf{n} \rangle + U_{\text{av}}) \dot{P}_{\text{exit}}$$

where  $\langle \cdot \rangle$  denotes the average over the inlet. Since the equation for  $P_{\text{exit}}$  is a DAE, it must be solved coupled to Navier–Stokes and it must be treated by a Vanka presmoothen and postsmoothen if iterative solvers are used.

The boundary conditions for the virtual outlet channel are inherited from the boundaries adjacent to the outlet channel. Virtual boundaries adjacent to walls (except slip walls) are treated as no-slip walls. Virtual boundaries adjacent to any other type of boundary are treated as slip-walls (or equivalently as symmetry boundaries).

### *No Viscous Stress*

---

For this module, and in addition to the Pressure, No Viscous Stress boundary condition, the viscous stress condition sets the viscous stress to zero:

$$\left(\mu(\nabla \mathbf{u} + (\nabla \mathbf{u})^T) - \frac{2}{3}\mu(\nabla \cdot \mathbf{u})\mathbf{I}\right)\mathbf{n} = \mathbf{0}$$

$$(\mu(\nabla \mathbf{u} + (\nabla \mathbf{u})^T))\mathbf{n} = \mathbf{0}$$

using the compressible/weakly compressible and the incompressible formulation, respectively.

The condition is not a sufficient outlet condition since it lacks information about the outlet pressure. It must hence be combined with pressure point constraints on one or several points or lines surrounding the outlet.

This boundary condition is numerically the least stable outlet condition, but can still be beneficial if the outlet pressure is nonconstant due to, for example, a nonlinear volume force.

### *Normal Stress Boundary Condition*

---

The total stress on the boundary is set equal to a stress vector of magnitude  $f_0$ , oriented in the negative normal direction:

$$\left(-p\mathbf{I} + \left(\mu(\nabla \mathbf{u} + (\nabla \mathbf{u})^T) - \frac{2}{3}\mu(\nabla \cdot \mathbf{u})\mathbf{I}\right)\right)\mathbf{n} = -f_0\mathbf{n}$$

$$(-p\mathbf{I} + \mu(\nabla \mathbf{u} + (\nabla \mathbf{u})^T))\mathbf{n} = -f_0\mathbf{n}$$

using the compressible/weakly compressible and the incompressible formulation, respectively.

This implies that the total stress in the tangential direction is zero. This boundary condition implicitly sets a constraint on the pressure which for 2D flows is

$$p = 2\mu \frac{\partial u_n}{\partial n} + f_0 \quad (5-40)$$

If  $\partial u_n / \partial n$  is small, [Equation 5-40](#) states that  $p \approx f_0$ .

The Normal Stress condition is the mathematically correct version of the condition (Ref. 4), but it is numerically less stable.

### *Pressure Boundary Condition*

---

For single-phase flow, a mathematically correct natural boundary condition for outlets is

$$\left(-p\mathbf{I} + \mu(\nabla\mathbf{u} + (\nabla\mathbf{u})^T) - \frac{2}{3}\mu(\nabla \cdot \mathbf{u})\mathbf{I}\right)\mathbf{n} = -p_0\mathbf{n} \quad (5-41)$$

$$(-p\mathbf{I} + \mu(\nabla\mathbf{u} + (\nabla\mathbf{u})^T))\mathbf{n} = -p_0\mathbf{n} \quad (5-42)$$

using the compressible/weakly compressible and the incompressible formulation, respectively.

This is a normal stress condition together with a no-tangential-stress condition. When  $\mu > 0$ , Equation 5-41 or Equation 5-42 can be supplemented with a tangential velocity condition

$$\mathbf{u} \cdot \mathbf{t} = 0 \quad (5-43)$$

If so, the no-tangential-stress condition is overridden. An issue with Equation 5-41 or Equation 5-42 is that it does not strongly enforce unidirectional flow on the boundary. If the prescribed pressure on an outlet is too high, parts of the outlet can actually have inflow. This is not as much of an issue for the Navier–Stokes equations as it is an issue for scalar transport equations solved along with the Navier–Stokes equations. Hence, when applying the **Pressure** boundary condition at an outlet or inlet you can further constrain the flow. With the **Suppress backflow** option

$$\begin{aligned} \left(-p\mathbf{I} + \mu(\nabla\mathbf{u} + (\nabla\mathbf{u})^T) - \frac{2}{3}\mu(\nabla \cdot \mathbf{u})\mathbf{I}\right)\mathbf{n} &= -\hat{p}_0\mathbf{n} \\ (-p\mathbf{I} + \mu(\nabla\mathbf{u} + (\nabla\mathbf{u})^T))\mathbf{n} &= -\hat{p}_0\mathbf{n} \\ \hat{p}_0 &\leq p_0 \end{aligned} \quad (5-44)$$

the normal stress is adjusted to keep

$$\mathbf{u} \cdot \mathbf{n} \geq 0 \quad (5-45)$$

Equation 5-44 effectively means that the prescribed pressure is  $p_0$  if  $\mathbf{u} \cdot \mathbf{n} \geq 0$ , but smaller at locations where  $\mathbf{u} \cdot \mathbf{n} < 0$ . This means that Equation 5-44 does not

completely prevent backflow, but the backflow is substantially reduced. Backflow is suppressed also when external forces are acting on the fluid, provided the magnitude of these forces are of the same order as the dynamic pressure at the outlet.

A pressure condition can also be applied at an inlet. In this case, either the normal stress is prescribed

$$\begin{aligned}\mathbf{n}^T \left( -p\mathbf{I} + \mu(\nabla\mathbf{u} + (\nabla\mathbf{u})^T) - \frac{2}{3}\mu(\nabla \cdot \mathbf{u})\mathbf{I} \right) \mathbf{n} &= -\hat{p}_0 \\ \mathbf{n}^T (-p\mathbf{I} + \mu(\nabla\mathbf{u} + (\nabla\mathbf{u})^T)) \mathbf{n} &= -\hat{p}_0 \\ \hat{p}_0 &\geq p_0\end{aligned}\tag{5-46}$$

together with the tangential condition in Equation 5-43, or, a general flow direction is prescribed.

$$\begin{aligned}\mathbf{r}_{\mathbf{u}}^T \left( -p\mathbf{I} + \mu(\nabla\mathbf{u} + (\nabla\mathbf{u})^T) - \frac{2}{3}\mu(\nabla \cdot \mathbf{u})\mathbf{I} \right) \mathbf{n} &= -\hat{p}_0(\mathbf{r}_{\mathbf{u}} \cdot \mathbf{n}) \\ \mathbf{r}_{\mathbf{u}}^T (-p\mathbf{I} + \mu(\nabla\mathbf{u} + (\nabla\mathbf{u})^T)) \mathbf{n} &= -\hat{p}_0(\mathbf{r}_{\mathbf{u}} \cdot \mathbf{n}) \\ \hat{p}_0 &\geq p_0 \\ \mathbf{u} - (\mathbf{u} \cdot \mathbf{r}_{\mathbf{u}})\mathbf{r}_{\mathbf{u}} &= \mathbf{0}, \quad \mathbf{r}_{\mathbf{u}} = \frac{\mathbf{d}_{\mathbf{u}}}{\|\mathbf{d}_{\mathbf{u}}\|}\end{aligned}\tag{5-47}$$

The “>” option is used with suppress backflow to have  $\mathbf{u} \cdot \mathbf{n} \leq 0$  or  $\mathbf{u} \cdot \mathbf{r}_{\mathbf{u}} \geq 0$ .

For incompressible single-phase flow, it is also allowed to specify the total pressure,  $p_{\text{tot}}$ , instead of the static pressure,  $p_{\text{stat}}$ , on inlet and outlet boundaries. It is more useful, for example, in pump applications. The pressure is then prescribed at the boundaries using Bernoulli’s principle,

$$p = p_{\text{stat}} = p_{\text{tot}} - \frac{1}{2}\rho|\mathbf{u}|^2\tag{5-48}$$

The equation is imposed with two options: **Average** and **Pointwise**.

In the first option,  $p_{\text{stat}}$  is prescribed by:

$$\mathbf{n}^T (-p\mathbf{I} + \mu(\nabla\mathbf{u} + (\nabla\mathbf{u})^T)) \mathbf{n} = \mathbf{n}^T (-p_{\text{stat}}\mathbf{I} + \mu(\nabla\mathbf{u} + (\nabla\mathbf{u})^T)) \mathbf{n}\tag{5-49}$$

where  $p_{\text{tot}}$  and  $|\mathbf{u}|^2$  are averaged over the boundaries using the aveop operator:

$$p_{\text{stat}} = \text{aveop}(p_{\text{tot}}) - \frac{1}{2}\rho \cdot \text{aveop}(|\mathbf{u}|^2)$$

For the second option, Equation 5-48 is prescribed pointwise.

See [Inlet](#), [Outlet](#), [Open Boundary](#), and [for](#) the individual node settings. Note that some modules have additional theory sections describing options available with that module.

### *Porous Interface*

---

This condition properly accounts for a sudden jump in porosity  $\varepsilon_p$  across boundary between different domains, giving the corresponding jump in stress across the interface. The emergence of a boundary layer on the upstream side of the interface is also revealed, which provides modifications to the behavior of the tangential velocity near the interface. The feature helps to avoid the need to add a very thin transition region, in which  $\varepsilon_{p,\text{upstream}}$  changes to  $\varepsilon_{p,\text{downstream}}$  continuously, while solving the Brinkman equation in such situations. Below, ‘-’ and ‘+’ (used as subscripts and superscripts) refer to the upstream and downstream side of the interface, respectively.

Whatever the option for **Continuity conditions** is chosen, the velocity conditions are

$$[\rho(\mathbf{u} \cdot \mathbf{n})]_{-}^{+} = 0, \quad \mathbf{u}_t|_{-}^{+} \equiv [\mathbf{u} - (\mathbf{u} \cdot \mathbf{n})\mathbf{n}]_{-}^{+} = 0$$

That is, the mass flux and tangential velocity across the interface are constant, and  $\mathbf{n}$  is assumed to be a normal pointing from ‘-’ to ‘+’. **Velocity and stress** option just imposes usual stress continuity adding a correction for a possible jump in density:

$$\left[ p\mathbf{n} - \mathbf{K}\mathbf{n} + \rho(\mathbf{u} \cdot \mathbf{n}) \left( \left[ \frac{1}{\varepsilon_p} \right]_{\text{av}} \right)^2 \mathbf{u} \right]_{-}^{+} = 0$$

The option **Velocity and porosity-corrected stress** (default) adds a contribution due to the inertial term, which is nontrivial (gives nonzero effect) when  $\varepsilon_p$  jumps across the interface:

$$\left[ p\mathbf{n} - \mathbf{K}\mathbf{n} + \rho(\mathbf{u} \cdot \mathbf{n}) \left( \left[ \frac{1}{\varepsilon_p} \right]_{\text{av}} \right)^2 \mathbf{u} + \rho(\mathbf{u} \cdot \mathbf{n}) \left( \frac{1}{2\varepsilon_p^2} \right) \mathbf{u}_{\text{av}} \right]_{-}^{+} = 0$$

Notice that  $\left[\frac{1}{\varepsilon_p}\right]_{\text{av}} = \left(\left[\frac{1}{\varepsilon_p}\right]_- + \left[\frac{1}{\varepsilon_p}\right]_+\right)/2$ ,  $\mathbf{u}_{\text{av}} = (\mathbf{u}_- + \mathbf{u}_+)/2$  and so on.

Then, the **Velocity and porosity-corrected stress with loss** option has a ‘pressure loss’ term:

$$\left[ p\mathbf{n} - \mathbf{K}\mathbf{n} + \rho(\mathbf{u} \cdot \mathbf{n}) \left( \left[ \frac{1}{\varepsilon_p} \right]_{\text{av}} \right)^2 \mathbf{u} + \rho(\mathbf{u} \cdot \mathbf{n}) \left( \frac{1}{2\varepsilon_p} \right) \mathbf{u}_{\text{av}} \right]_+ + p^{(\text{loss})} \mathbf{n} = 0$$

This loss occurs in the downstream direction. Its mechanism is similar to the mechanism of common engineering ‘total pressure loss’. Indeed, ‘expansion’ and ‘contraction’ across the interface experienced by the flow on the microscopic level (due to increasing or decreasing porosity,  $\varepsilon_p$ , respectively), are roughly equivalent to expansion and contraction of flow in a pipe with geometrical variations. Accordingly, it is assumed that only the normal velocity component is responsible for the loss. In the case of normal flow and negligible viscous term the pipe-analogy is quite exact.

Subsequently, **Pressure loss model** should be specified. Choosing **User-defined loss coefficients** requires values of **Expansion loss coefficient** and **Contraction loss coefficient** ( $K_{\text{exp}} = 1$  and  $K_{\text{contr}} = 0.5$  are default values). The resulting losses on the ‘expansion’ and ‘contraction’ boundaries are:

$$p^{(\text{loss,expansion})} = K_{\text{exp}} \left( \left( \frac{\rho(\mathbf{u} \cdot \mathbf{n})^2}{2\varepsilon_p^2} \right) \right)_-,$$

$$p^{(\text{loss,contraction})} = K_{\text{contr}} \left( \frac{\rho(\mathbf{u} \cdot \mathbf{n})^2}{2\varepsilon_p^2} \right)_+$$

**Borda–Carnot** option results in the following losses:

$$p^{(\text{loss,expansion})} = \frac{\rho_{\text{av}}}{2} \left( \left[ \frac{(\mathbf{u} \cdot \mathbf{n})}{\varepsilon_p} \right]_+ - \left[ \frac{(\mathbf{u} \cdot \mathbf{n})}{\varepsilon_p} \right]_- \right)^2,$$

$$p^{(\text{loss,contraction})} = \frac{1}{2} \left( \frac{\rho(\mathbf{u} \cdot \mathbf{n})^2}{\varepsilon_p^2} \right)_+ \left( \frac{1}{c_{\text{vc}}} - 1 \right)^2$$

and requires to choose **Vena contracta model**. The **User defined** option asks for value of **Vena contracta coefficient** ( $c_{\text{vc}} = 0.5$  by default). **Weisbach** option computes the coefficient based on the ratio of porosities across the interface:

$$c_{vc} = c_{vc,ll} + (1 - c_{vc,ll}) \left( \frac{\varepsilon_{p,+}}{\varepsilon_{p,-}} \right)^{n_{vc}}$$

and requires inputs for **Lower limit** and **Exponent** ( $c_{vc,ll} = 0.63$  and  $n_{vc} = 3$  are default values).

Although the velocity conditions formally look the same for all **Continuity conditions** options, the latter two (containing the inertial correction due to the porosity jump) lead to an extra nontrivial effect. Namely, the tangential velocity exponentially evolves over a boundary layer formed on the upstream side of the interface boundary. This boundary layer has a characteristic length equal to

$$l_- = \frac{\mu \varepsilon_{p,-}}{\rho(\mathbf{u} \cdot \mathbf{n})}$$

The ratio of the tangential velocities right after the interface (‘downstream’) and outside the boundary layer (‘upstream infinity’) is

$$\frac{|\mathbf{u}_{t,+}|}{|\mathbf{u}_{t,\text{upstream infinity}}|} = \frac{2\varepsilon_{p,+}/\varepsilon_{p,-}}{\varepsilon_{p,+}/\varepsilon_{p,-} + \varepsilon_{p,-}/\varepsilon_{p,+}}$$

In terms of the interstitial velocity,  $\mathbf{u}^{(i)} = \mathbf{u}/\varepsilon_p$ , this results in:

$$\frac{|\mathbf{u}_{t,+}^{(i)}|}{|\mathbf{u}_{t,\text{upstream infinity}}^{(i)}|} = \frac{2}{\varepsilon_{p,+}/\varepsilon_{p,-} + \varepsilon_{p,-}/\varepsilon_{p,+}} \leq 1$$

Obviously, tangential component of the interstitial kinetic energy is lost across the interface. For low viscosity and high normal-flow component, when  $l_u$  is much lower than  $l_{\text{geom}}$  (the characteristic geometry length) there are apparent variations in  $\mathbf{u}_t$  and  $\mathbf{u}_t^{(i)}$  in a thin boundary layer on the upstream side of the interface. However, for the cases with high viscosity or nearly interface-parallel flow,  $l_u$  is much larger than  $l_{\text{geom}}$ , and any variations in  $\mathbf{u}_t$  and  $\mathbf{u}_t^{(i)}$  are virtually invisible.

Notice that the feature does not take into account possible underresolved porous scale, as is described in [Theory for the Free and Porous Media Flow, Darcy Interface](#).

## Mass Sources for Fluid Flow

---

There are two types of mass sources in a Single-Phase Flow interface: point sources and line sources.



These features require at least one of the following licenses: Battery Design Module, CFD Module, Chemical Reaction Engineering Module, Corrosion Module, Electrochemistry Module, Electrodeposition Module, Fuel Cell & Electrolyzer Module, Microfluidics Module, Pipe Flow Module, Polymer Flow Module, or Subsurface Flow Module.

---

### POINT SOURCE

A point source is theoretically formed by taking a mass injection/ejection,  $\dot{Q}$  (SI unit:  $\text{kg}/(\text{m}^3 \cdot \text{s})$ ), in a small volume  $\delta V$  and then letting the size of the volume tend to zero while keeping the total mass flux constant. Given a point source strength,  $\dot{q}_p$  (SI unit:  $\text{kg}/\text{s}$ ), this can be expressed as

$$\lim_{\delta V \rightarrow 0} \int_{\delta V} \dot{Q} = \dot{q}_p \quad (5-50)$$

An alternative way to form a point source/sink is to assume that mass is injected/extracted through the surface of a small object. Letting the object surface area tend to zero while keeping the mass flux constant, results in the same point source. For this alternative approach, effects resulting from the physical object volume, such as drag and fluid displacement, need to be neglected.

The weak contribution

$$\dot{q}_p \text{test}(p)$$

is added to a point in the geometry. As can be seen from [Equation 5-50](#),  $\dot{Q}$  must tend to plus or minus infinity as  $\delta V$  tends to zero. This means that in theory the pressure also tends to plus or minus infinity.

Observe that “point” refers to the physical representation of the source. A point source can therefore only be added to points in 3D components and to points on the symmetry axis in 2D axisymmetry components. Other geometrical points in 2D components represent physical lines.

The finite element representation of [Equation 5-50](#) corresponds to a finite pressure in a point with the effect of the point source spread out over a region around the point.

The size of the region depends on the mesh and on the strength of the source. A finer mesh gives a smaller affected region, but also a more extreme pressure value. It is important not to mesh too finely around a point source since the resulting pressure can result in unphysical values for the density, for example. It can also have a negative effect on the condition number for the equation system.

### LINE SOURCE

A line source can theoretically be formed by assuming a source of strength  $\dot{Q}$  (SI unit:  $\text{kg}/(\text{m}^3 \cdot \text{s})$ ), located within a tube with cross-sectional area  $\delta S$  and then letting  $\delta S$  tend to zero, while keeping the total mass flux per unit length constant. Given a line source strength,  $\dot{q}_l$  (SI unit:  $\text{kg}/(\text{m} \cdot \text{s})$ ), this can be expressed as

$$\lim_{\delta S \rightarrow 0} \int_{\delta S} \dot{Q} = \dot{q}_l \quad (5-51)$$

As in the point source case, an alternative approach is to assume that mass is injected/extracted through the surface of a small object. This results in the same mass source, but requires that effects on the fluid resulting from the physical object volume are neglected.

The weak contribution

$$\dot{q}_l \text{test}(p)$$

is added to lines in 3D or to points in 2D (which represent cut-through views of lines). Line sources can also be added to the axisymmetry line in 2D axisymmetry components. It cannot, however, be added to geometrical lines in 2D because they represent physical planes.

As with a point source, it is important not to mesh too finely around the line source.



For feature node information, see [Line Mass Source](#) and [Point Mass Source](#).

---

---

For the Reacting Flow in Porous Media, Diluted Species interface, which is available with the CFD Module, Chemical Reaction Engineering Module, or Battery Design Module, these shared physics nodes are renamed as follows:



- The **Line Mass Source** node is available as two nodes, one for the fluid flow (**Fluid Line Source**) and one for the species (**Species Line Source**).
- The **Point Mass Source** node is available as two nodes, one for the fluid flow (**Fluid Point Source**) and one for the species (**Species Point Source**).

---

### *Numerical Stability — Stabilization Techniques for Fluid Flow*

---

The momentum equation (Equation 5-28 or Equation 5-30) is a (nonlinear) convection–diffusion equation. Such equations can easily become unstable if discretized using the Galerkin finite element method. Stabilized finite element methods are usually necessary in order to obtain physical solutions. The stabilization settings are found in the main Fluid Flow interface features. To display this section, click the **Show More Options** button (  ) and select **Stabilization** in the **Show More Options** dialog.

There are three types of stabilization methods available for Navier–Stokes — *streamline diffusion*, *crosswind diffusion*, and *isotropic diffusion*. Streamline diffusion and crosswind diffusion are consistent stabilization methods, whereas isotropic diffusion is an inconsistent stabilization method.

For optimal functionality, the exact weak formulations of and constants in the streamline diffusion and crosswind diffusion methods depend on the order of the shape functions (basis functions) for the elements. The values of constants in the streamline diffusion and crosswind diffusion methods follow Ref. 5 and Ref. 6.

#### **STREAMLINE DIFFUSION**

For strongly coupled systems of equations, the streamline diffusion method must be applied to the system as a whole rather than to each equation separately. These ideas were first explored by Hughes and Mallet (Ref. 8) and were later extended to Galerkin least-squares (GLS) applied to the Navier–Stokes equations (Ref. 9). This is the streamline diffusion formulation that COMSOL Multiphysics supports.

Streamline diffusion is active by default because it is necessary when convection is dominating the flow.

The governing equations for incompressible flow are subject to the Babuška–Brezzi condition, which states that the shape functions (basis functions) for pressure must be of lower order than the shape functions for velocity. If the incompressible Navier–Stokes equations are stabilized by streamline diffusion, it is possible to use equal-order interpolation. Hence, streamline diffusion is necessary when using first-order elements for both velocity and pressure. This applies also if the model is solved using geometric multigrid (either as a solver or as a preconditioner) and at least one multigrid hierarchy level uses linear Lagrange elements.

### CROSSWIND DIFFUSION

Crosswind diffusion can also be formulated for systems of equations, and when applied to the Navier–Stokes equations it becomes a shock-capturing operator. COMSOL Multiphysics supports the formulation in [Ref. 9](#) with a shock-capturing viscosity of the Hughes–Mallet type [Ref. 8](#).

Incompressible flows do not contain shock waves, but crosswind diffusion is still useful for introducing extra diffusion in sharp boundary layers and shear layers that otherwise would require a very fine mesh to resolve.

Crosswind diffusion is active by default as it makes it easier to obtain a solution even if the problem is fully resolved by the mesh. Crosswind diffusion also enables the iterative solvers to use inexpensive presmoothers. If crosswind diffusion is deactivated, more expensive preconditioners must be used instead.

### STABILIZATION TIME SCALES

The time-scale tensor for time-dependent problems should in theory depend on a time-scale that many references just set to the time-step taken by the time-solver,  $\Delta t$  (see, for example, [Ref. 9](#) and [Ref. 10](#)). This simple approach does not, however, necessarily reflect on the actual time-scales in the physics. A typical example is reacting flows where the time step is often guided by fast reactions, while the flow develops relatively slowly. The COMSOL Multiphysics software can therefore replace  $\Delta t^2$  in the time-scale tensor with measures of type  $(1/(\Delta \tilde{t})^2)^{-1}$ , which are calculated from projections of weak expressions in a fashion similar to those in [Ref. 11](#). These measures of the time scale are used when **Use dynamic subgrid time scale** is activated.

The **Limit small time steps effect on stabilization time scale** option can be used to ramp down the time-step contribution in the stabilization when the time step becomes much smaller than the convective and diffusive time scales. This option prevents loss of pressure stabilization at such small time steps.

## ISOTROPIC DIFFUSION

Isotropic diffusion adds diffusion to the Navier–Stokes equations. Isotropic diffusion significantly reduces the accuracy of the solution but does a very good job at reducing oscillations. The stability of the continuity equation is not improved.



### Numerical Stabilization and Iterative

---

#### *Solvers for Laminar Flow*

---

The Navier–Stokes equations constitute a nonlinear equation system. A nonlinear solver must hence be applied to solve the problem. The nonlinear solver iterates to reach the final solution. In each iteration, a linearized version of the nonlinear system is solved using a linear solver. In the time-dependent case, a time marching method must also be applied. The default suggestions for each of these solver elements are discussed below.

#### **NONLINEAR SOLVER**

The nonlinear solver method depends on if the model solves a stationary or a time-dependent problem.

##### *Stationary Solver*

In the stationary case, a fully coupled, damped Newton method is applied. The initial damping factor is low since a full Newton step can be harmful unless the initial values are close to the final solution. The nonlinear solver algorithm automatically regulates the damping factor in order to reach a converged solution.

For advanced models, the automatically damped Newton method might not be robust enough. A pseudo time-stepping algorithm can then be invoked. See [Pseudo Time Stepping for Laminar Flow Models](#).

##### *Time-Dependent Solver*

In the time-dependent case, the initial guess for each time step is (loosely speaking) the previous time step, which is a very good initial value for the nonlinear solver. The automatic damping algorithm is then not necessary. The damping factor in the Newton method is instead set to a constant value slightly smaller than one. Also, for the same reason, it suffices to update the Jacobian once per time step.

It is seldom worth the extra computational cost to update the Jacobian more than once per time step. For most models it is more efficient to restrict the maximum time step or possibly lower the damping factor in the Newton method.

### **LINEAR SOLVER**

The linearized Navier–Stokes equation system has saddle point character, unless the density depends on the pressure. This means that the Jacobian matrix has zeros on the diagonal. Even when the density depends on the pressure, the equation system effectively shares many numerical properties with a saddle point system.

For small 2D and 3D models, the default solver suggestion is a direct solver. Direct solvers can handle most nonsingular systems and are very robust and also very fast for small models. Unfortunately, they become slow for large models and their memory requirement scales as somewhere between  $N^{1.5}$  and  $N^2$ , where  $N$  is the number of degrees of freedom in the model. The default suggestion for large 2D and 3D models is therefore the iterative GMRES solver. The memory requirement for an iterative solver optimally scales as  $N$ .

GMRES is accelerated by a multigrid method, per default the smoothed aggregation algebraic multigrid (SAAMG) method. The cost of SAAMG is typically very low compared to the number of GMRES iterations necessary if no multigrid method is used. As the name implies, SAAMG builds its coarser meshes algebraically, so the application requires no additional meshes in order to employ SAAMG. In contrast, the geometric multigrid (GMG) method requires actual meshes. If a sufficient number of multigrid levels can be constructed, GMG is often faster than SAAMG. GMG is also superior for cluster computations and for shared-memory computations with many cores. When the default linear solver is GMRES, an optional, but deactivated, linear solver node is available where GMRES is accelerated by GMG.

Multigrid methods need smoothers, but the saddle point character of the linear system restricts the number of applicable smoothers. The choices are further restricted by the anisotropic meshes frequently encountered in fluid-flow problems. The efficiency of the smoothers is highly dependent on the numerical stabilization. Iterative solvers perform at their best when both [Streamline Diffusion](#) and [Crosswind Diffusion](#) are active.

The default smoother for P1+P1 elements is SCGS. This is an efficient and robust smoother specially designed to solve saddle point systems on meshes that contain anisotropic elements. The SCGS smoother works well even without crosswind diffusion. SCGS can sometimes work for higher-order elements, especially if **Method** in the SCGS settings is set to **Mesh element lines**. But there is no guarantee for this, so the

default smoother for higher order elements is an SOR Line smoother. SOR Line handles mesh anisotropy but does not formally address the saddle point character. It does, however, function in practice provided that streamline diffusion and crosswind diffusion are both active.

A different kind of saddle point character can arise if the equation system contains ODE variables. Some advanced boundary conditions can add equations with such variables. These variables must be treated with the Vanka algorithm. SCGS includes an option to invoke Vanka. Models with higher-order elements must apply SCGS or use the Vanka smoother. The latter is the default suggestion for higher-order elements, but it does not work optimally for anisotropic meshes.

### TIME-DEPENDENT SOLVERS

The default time-dependent solver for Navier–Stokes is the BDF method with maximum order set to two. Higher BDF orders are not stable for transport problems in general nor for Navier–Stokes in particular.

BDF methods have been used for a long time and are known for their stability. However, they can have severe damping effects, especially the lower-order methods. Hence, if robustness is not an issue, a model can benefit from using the generalized- $\alpha$  method instead. Generalized- $\alpha$  is a solver that has properties similar to those of the second-order BDF solver but it is much less diffusive.

Both BDF and generalized- $\alpha$  are per default set to automatically adjust the time step. While this works well for many models, extra efficiency and accuracy can often be gained by specifying a maximum time step. It is also often beneficial to specify an initial time step to make the solver progress smoothly in the beginning of the time series.



- [Time-Dependent Solver](#)
  - [Multigrid, Direct, Iterative, SCGS, SOR Line, and Vanka](#)
  - [Stationary Solver](#)
- 

### *Pseudo Time Stepping for Laminar Flow Models*

---

A stationary formulation has per definition no time derivatives and [Equation 5-30](#) reduces to:

$$\rho(\mathbf{u} \cdot \nabla)\mathbf{u} = \nabla \cdot [-p\mathbf{I} + \mu(\nabla\mathbf{u} + (\nabla\mathbf{u})^T)] + \mathbf{F} \quad (5-52)$$

Solving Equation 5-52 requires a starting guess that is close enough to the final solution. If no such guess is at hand, the fully transient problem can be solved instead. This is, however, a rather costly approach in terms of computational time. An intermediate approach is to add a fictitious time derivative to Equation 5-52:

$$\rho \frac{\mathbf{u} - \text{nojac}(\mathbf{u})}{\Delta \tilde{t}} + \rho(\mathbf{u} \cdot \nabla)\mathbf{u} = \nabla \cdot [-p\mathbf{I} + \mu(\nabla\mathbf{u} + (\nabla\mathbf{u})^T)] + \mathbf{F}$$

where  $\Delta \tilde{t}$  is a *pseudo time step*. Since  $\mathbf{u} - \text{nojac}(\mathbf{u})$  is always zero, this term does not affect the final solution. It does, however, affect the discrete equation system and effectively transforms a nonlinear iteration into a step of size  $\Delta \tilde{t}$  of a time-dependent solver.

Pseudo time stepping is not active per default. The pseudo time step  $\Delta \tilde{t}$  can be chosen individually for each element based on the local CFL number:

$$\Delta \tilde{t} = \text{CFL}_{\text{loc}} \frac{h}{|\mathbf{u}|}$$

where  $h$  is the mesh cell size. A small CFL number means a small time step. It is practical to start with a small CFL number and gradually increase it as the solution approaches steady state.

If the automatic expression for  $\text{CFL}_{\text{loc}}$  is set to the built-in variable `CFLCMP`, then the automatic setting suggests a PID regulator for the pseudo time step in the default solver. The PID regulator starts with a small CFL number and increases  $\text{CFL}_{\text{loc}}$  as the solution comes closer to convergence.

The default manual expression is

$$\begin{aligned} & 1.3^{\min(\text{niterCMP}, 9)} + \\ & \text{if}(\text{niterCMP} > 20, 9 \cdot 1.3^{\min(\text{niterCMP} - 20, 9)}, 0) + \\ & \text{if}(\text{niterCMP} > 40, 90 \cdot 1.3^{\min(\text{niterCMP} - 40, 9)}, 0) \end{aligned} \quad (5-53)$$

The variable `niterCMP` is the nonlinear iteration number. It is equal to one for the first nonlinear iteration.  $\text{CFL}_{\text{loc}}$  starts at 1.3 and increases by 30% each iteration until it reaches  $1.3^9 \approx 10.6$ . It remains there until iteration number 20 at which it starts to increase until it reaches approximately 106. A final increase after iteration number 40

then takes it to 1060. Equation 5-53 can, for some advanced flows, increase  $CFL_{loc}$  too slowly or too quickly.  $CFL_{loc}$  can then be tuned for the specific application.



For details about the CFL regulator, see [Pseudo Time Stepping](#).

---

### *Nitsche Constraints*

---

Some boundary conditions are implemented using Nitsche constraints. These boundary conditions include

- [Wall](#) — Slip, sliding walls, and moving walls (that is, walls with nonzero translational velocity).
- [Periodic Flow Condition](#)
- [Flow Continuity](#)

The formulation used in the Fluid Flow interfaces in single-phase flow interfaces corresponds to the Symmetric Interior Penalty Galerkin method (SIPG). The SIPG method can be regarded to satisfy the boundary conditions in an integral sense rather than pointwise. More information on SIPG can be found in [Ref. 15](#).

In particular, the SIPG formulation includes a penalty parameter that must be large enough for the formulation to be coercive. The higher the value, the better the boundary condition is fulfilled, but a value that is too high results in an ill-conditioned equation system. The penalty parameter is implemented according to [Ref. 16](#).

### *Particle Tracing in Fluid Flow*

---

The Particle Tracing Module is available to assist with these types of modeling problems.

It is possible to model particle tracing with COMSOL Multiphysics provided that the impact of the particles on the flow field is negligible. First compute the flow field, and then, as an analysis step, calculate the motion of the particles. The motion of a particle is defined by Newton's second law

$$m \frac{d^2 \mathbf{x}}{dt^2} = \mathbf{F} \left( t, \mathbf{x}, \frac{d\mathbf{x}}{dt} \right)$$

where  $\mathbf{x}$  is the position of the particle,  $m$  the particle mass, and  $\mathbf{F}$  is the sum of all forces acting on the particle. Examples of forces acting on a particle in a fluid are the drag force, the buoyancy force, and the gravity force. The drag force represents the force that a fluid exerts on a particle due to a difference in velocity between the fluid and the particle. It includes the viscous drag, the added mass, and the Basset history term. Several empirical expressions have been suggested for the drag force. One of those is the one proposed by Khan and Richardson (Ref. 13). That expression is valid for spherical particles for a wide range of particle Reynolds numbers. The particle Reynolds number is defined as

$$\text{Re}_p = \frac{|\mathbf{u} - \mathbf{u}_p| 2r \rho}{\mu}$$

where  $\mathbf{u}$  is the velocity of the fluid,  $\mathbf{u}_p$  the particle velocity,  $r$  the particle radius,  $\rho$  the fluid density, and  $\mu$  the dynamic viscosity of the fluid. The empirical expression for the drag force according to Khan and Richardson is

$$\mathbf{F} = \pi r^2 \rho |\mathbf{u} - \mathbf{u}_p| (\mathbf{u} - \mathbf{u}_p) [1.84 \text{Re}_p^{-0.31} + 0.293 \text{Re}_p^{0.06}]^{3.45}$$



The model *Flow Past a Cylinder* (Application Library path **COMSOL\_Multiphysics/Fluid\_Dynamics/cylinder\_flow**) demonstrates how to add and set up particle tracing in a plot group using the **Particle Tracing with Mass** node. It uses the predefined Khan–Richardson model for the drag force and neglects gravity and buoyancy forces.

### *References for the Single-Phase Flow, Laminar Flow Interfaces*

1. G.G. Stokes, *Trans. Camb. Phil. Soc.*, vol. 8, pp. 287–305, 1845.
2. P.M. Gresho and R.L. Sani, *Incompressible Flow and the Finite Element Method, Volume 2: Isothermal Laminar Flow*, John Wiley & Sons, 2000.
3. G.K. Batchelor, *An Introduction To Fluid Dynamics*, Cambridge University Press, 1967.
4. R.L. Panton, *Incompressible Flow*, 2nd ed., John Wiley & Sons, 1996.
5. I. Harari and T.J.R. Hughes, “What are  $C$  and  $h$ ? Inequalities for the Analysis and Design of Finite Element Methods,” *Comput. Methods Appl. Mech. Eng.*, vol. 97, pp. 157–192, 1992.

6. Y. Bazilevs, V.M. Calo, T.E. Tezduyar, and T.J.R. Hughes, “YZ $\beta$  Discontinuity Capturing for Advection-dominated Processes with Application to Arterial Drug Delivery,” *Int. J. Num. Meth. Fluids*, vol. 54, pp. 593–608, 2007.
7. R.B. Bird, W.E. Stewart, and E.N. Lightfoot, *Transport Phenomena*, 2nd ed., John Wiley & Sons, 2007.
8. T.J.R. Hughes and M. Mallet, “A New Finite Element Formulation for Computational Fluid Dynamics: III. The Generalized Streamline Operator for Multidimensional Advective-Diffusive System,” *Comput. Methods Appl. Mech. Eng.*, vol. 58, pp. 305–328, 1986.
9. G. Hauke and T.J.R. Hughes, “A Unified Approach to Compressible and Incompressible Flows,” *Comput. Methods Appl. Mech. Eng.*, vol. 113, pp. 389–395, 1994.
10. G. Hauke, “Simple Stabilizing Matrices for the Computation of Compressible Flows in Primitive Variables,” *Comput. Methods Appl. Mech. Eng.*, vol. 190, pp. 6881–6893, 2001.
11. M.-C. Hsu, Y. Bazilevs, V.M. Cali, T.E. Tezduyar, and T.J.R. Hughes, “Improving stability of stabilized and multiscale formulations in flow simulations at small time steps,” *Comput. Methods Appl. Mech. Eng.*, vol. 199, pp. 828–840, 2010.
12. D.J. Tritton, *Physical Fluid Dynamics*, 2nd ed., Oxford University Press, 1988.
13. J.M. Coulson and J.F. Richardson, “Particle Technology and Separation Processes,” *Chemical Engineering, Volume 2*, Butterworth-Heinemann, 2002.
14. J.L. Guermond, P. Mineev, and J. Shen, “An overview of projection methods for incompressible flows,” *Comput. Methods Appl. Mech. Eng.*, vol. 195, pp. 6011–6045, 2006.
15. B. Rivière, *Discontinuous Galerkin Methods for Solving Elliptic and Parabolic Equations*, SIAM, 2008.
16. Y. Epshteyn and B. Rivière, “Estimation of penalty parameters for symmetric interior penalty Galerkin methods,” *J. Comput. Appl. Math.*, vol. 206, pp. 843–872, 2007.
17. R.P. Chhabra and J.F. Richardson, *Non-Newtonian Flow and Applied Rheology*, 2nd ed., Elsevier, 2008.
18. Y. Bazilevs and T.J.R. Hughes, “Weak imposition of Dirichlet boundary conditions in fluid mechanics,” *Comput. Fluids*, vol. 36, pp. 12–26, 2007.



# Theory for the Darcy's Law Interface

The [Darcy's Law Interface](#) theory is described in this section:

- [About Darcy's Law](#)
- [Darcy's Law — Equation Formulation](#)
- [Storage Models](#)
- [Average Linear Velocity](#)
- [Dual Porosity and Dual Permeability Theory](#)
- [References for the Darcy's Law Interface](#)

## *About Darcy's Law*

---

In a porous medium, the global transport of momentum by shear stresses in the fluid is often negligible, because the pore walls impede momentum transport to the fluid outside the individual pores. A detailed description, down to the resolution of every pore, is not practical in most applications. A homogenization of the porous and fluid media into a single medium is a common alternative approach. Darcy's law together with the continuity equation and equation of state for the pore fluid (or gas) provide a complete mathematical model suitable for a wide variety of applications involving porous media flows, for which the pressure gradient is the major driving force.

Darcy's law describes fluid movement through interstices in a porous medium. Because the fluid loses considerable energy to frictional resistance within pores, flow velocities in porous media are very low. The Darcy's Law interface can be applied to small-scale tasks in chemical engineering as well as to large-scale geophysical or hydrological tasks such as water moving in an aquifer or stream bank, oil migrating to a well, and even magma rising through the earth to a chamber in a volcano (see [Ref. 1](#), [Ref. 2](#), [Ref. 3](#), and [Ref. 4](#)). Also set up multiple Darcy's Law interfaces to model multiphase flows involving more than one mobile phase.

Darcy's law describes flow in porous media driven by gradients in the hydraulic potential field, which has units of pressure. For many applications it is convenient to represent the total hydraulic potential or the pressure and the gravitational components with equivalent heights of fluid or head. Division of potential by the fluid weight can simplify modeling because units of length make it straightforward to compare to many physical data. Consider, for example, fluid levels in wells, stream heights, topography, and velocities. The physics interface also supports specifying

boundary conditions and result evaluation using hydraulic head and pressure head. In the physics interface, pressure is always the dependent variable.

### *Darcy's Law — Equation Formulation*

---

Darcy's law states that the velocity field is determined by the pressure gradient, the fluid viscosity, and the structure of the porous medium:

$$\mathbf{u} = -\frac{\kappa}{\mu} \nabla p \quad (5-54)$$

In this equation,  $\mathbf{u}$  is the Darcy's velocity or specific discharge vector (SI unit: m/s);  $\kappa$  is the permeability of the porous medium (SI unit:  $\text{m}^2$ );  $\mu$  is the fluid's dynamic viscosity (SI unit: Pa·s);  $p$  is the pore pressure (SI unit: Pa) and  $\rho$  is the density of the fluid (SI unit:  $\text{kg}/\text{m}^3$ ).



- The above equation formulation is called linear Darcy's law. The applicability of this formulation is discussed in the chapter [About Darcian and Non-Darcian Flow](#) in the *Porous Media Flow Module User's Guide*.
- Permeability can be defined in different ways, either directly or based on predefined permeability models. These are described in detail in the chapter [Permeability Models](#).
- For a detailed overview of the permeability models available in each product visit [www.comsol.com/products/specifications/](http://www.comsol.com/products/specifications/).

---

The Darcy's Law interface combines Darcy's law with the continuity equation

$$\frac{\partial}{\partial t}(\rho \varepsilon_p) + \nabla \cdot (\rho \mathbf{u}) = Q_m \quad (5-55)$$

In the above equation,  $\rho$  is the fluid density (SI unit:  $\text{kg}/\text{m}^3$ ),  $\varepsilon_p$  is the porosity, and  $Q_m$  is a mass source term (SI unit:  $\text{kg}/(\text{m}^3 \cdot \text{s})$ ). Porosity is defined as the fraction of the control volume that is occupied by pores. Thus, the porosity can vary from zero for pure solid regions to unity for domains of free flow.

For large-scale applications it might be necessary to take gravity effects into account. Darcy's law then applies when the gradient in hydraulic potential drives fluid movement in the porous medium. Darcy's law then has the form:

$$\mathbf{u} = -\frac{\kappa}{\mu}(\nabla p - \rho \mathbf{g}) \quad (5-56)$$



- See the section [Gravity Effects](#) in the *Subsurface Flow Module User's Guide*.
- Note that gravity effects are only included in some modules. For a detailed overview of the functionality available in each product visit [www.comsol.com/products/specifications/](http://www.comsol.com/products/specifications/).
- Gravity effects are not active by default. Select the checkbox **Include gravity** to activate the acceleration of gravity. Setting the elevation  $D$  to zero also turns off gravity effects.

### Storage Models

The continuity equation ([Equation 5-55](#)) allows flexible specification of relationships between parameters like density or permeability with respect to variables such as pressure, temperature, concentration, and more.

Expanding the time-derivative term and defining the porosity and density as functions of the pressure and using the chain rule results in

$$\frac{\partial}{\partial t}(\rho \varepsilon_p) = \varepsilon_p \frac{\partial \rho}{\partial t} + \rho \frac{\partial \varepsilon_p}{\partial t} = \varepsilon_p \frac{\partial \rho}{\partial p} \frac{\partial p}{\partial t} + \rho \frac{\partial \varepsilon_p}{\partial p} \frac{\partial p}{\partial t}$$

By inserting the definition of fluid compressibility  $\chi_f = (1/\rho)(\partial \rho / \partial p)$  to the right-hand side and rearrange the following expression is obtained

$$\frac{\partial(\rho \varepsilon_p)}{\partial t} = \rho \left( \varepsilon_p \chi_f + \frac{\partial \varepsilon_p}{\partial p} \right) \frac{\partial p}{\partial t} = \rho S_p \frac{\partial p}{\partial t}$$

Using this relation, the generalized governing equation ([Equation 5-55](#)) takes the following form:

$$\rho S_p \frac{\partial p}{\partial t} + \nabla \cdot (\rho \mathbf{u}) = Q_m \quad (5-57)$$

In this equation,  $S_p$  is the storage coefficient (SI unit: 1/Pa), which can be interpreted as the weighted compressibility of the porous material and the fluid. The storage can be an expression involving results from a solid-deformation equation or an expression involving temperatures and concentrations from other analyses. The Darcy's Law

interface implements Equation 5-57 in the **Porous Medium** node, which explicitly includes different storage models to choose from:

- **From density and porosity**, where the storage directly depends on changes in porosity or fluid density
- **Linearized storage**, which defines  $S_p$  using the compressibility of the fluid  $\chi_f$  and of the porous matrix  $\chi_p$  according to

$$S_p = \varepsilon_p \chi_f + (1 - \varepsilon_p) \chi_p$$

- **Poroelastic storage** where

$$S_p = \varepsilon_p \chi_f.$$



Storage models are only available for the Subsurface Flow Module and the Porous Media Flow Module. For a detailed overview of the functionality available in each product visit [www.comsol.com/products/specifications/](http://www.comsol.com/products/specifications/).

### *Average Linear Velocity*

Because fluids typically occupy only 10% to 50% of a porous medium, it follows that velocities within the pore channels exceed the Darcy velocity,  $\mathbf{u}$ , on the order of two to ten times. For clarity, the physics interface includes the average linear velocity within the pores,  $\mathbf{u}_\alpha$ , (also termed the seepage velocity) defined as  $\mathbf{u}_\alpha = \mathbf{u}/\varepsilon_p$ , where  $\varepsilon_p$  is the porosity.

### *Dual Porosity and Dual Permeability Theory*

The first well known publication on this topic is “The Behavior of Naturally Fractured Reservoirs” by J.E. Warren and P.J. Root from 1963. Since then the researchers further developed the idea of a dual porosity/permeability type of a porous medium. One of the well established models is based on the findings of H. Gerke and M. van Genuchten (Ref. 10). Basically the idea behind is to solve for each part of the porous medium (macro- and micropores) the relevant equations and connect them via an exchange term.

#### **DUAL POROSITY MEDIUM**

Darcy’s Law is solved for the macropores and taking into account their volume fraction  $\theta_M$  the equation reads:

$$\theta_M \left( \rho S_{p,M} \frac{\partial p_M}{\partial t} + \nabla \cdot (\rho \mathbf{u}_M) \right) = \theta_M Q_M - Q_{ip} \quad (5-58)$$

The term  $Q_{ip}$  describes the mass source from the [Interporosity Flow](#) which is the mass transfer from the macropores to the micropores system. An additional ODE for the (passive) micropores is solved which only act as additional storage volume:

$$(1 - \theta_M) \left( \rho S_{p,m} \frac{\partial p_m}{\partial t} \right) = (1 - \theta_M) Q_M + Q_{ip}.$$

The indices  $M$  and  $m$  stand for macropores and micropores, respectively.

### DUAL PERMEABILITY MEDIUM

Darcy's law has to be solved for both the macroscale system and the microscale system:

$$\begin{aligned} \theta_M \left( \frac{\partial}{\partial t} (\varepsilon_{p,M} \rho) + \nabla \cdot (\rho \mathbf{u}_M) \right) &= -Q_{ip} + \theta_M Q_m \\ (1 - \theta_M) \left( \frac{\partial}{\partial t} (\varepsilon_{p,m} \rho) + \nabla \cdot (\rho \mathbf{u}_m) \right) &= Q_{ip} + (1 - \theta_M) Q_m \\ p &= \theta_M p_M + (1 - \theta_M) p_m \end{aligned} \quad (5-59)$$

$\theta_M$  is the volume fraction of the macropores,  $Q_{ip}$  denotes the interporosity flow, signifying the mass transfer from the macropores (identified by index  $M$ ) to the micropores (identified by index  $m$ ).

Solving Darcy's law for both systems entails solving two equations, each associated with dependent pressure variables  $p_m$  and  $p_M$ . These equations are coupled via  $Q_{ip}$ . From this, average quantities for the dual permeability medium as a whole are computed. The average pressure of the dual permeability medium is defined as:

$$p = \theta_M p_M + (1 - \theta_M) p_m$$

Likewise, average values for permeability, storage, velocity and other relevant parameters are computed.

### UNSATURATED DUAL PERMEABILITY MEDIUM

Use the **Unsatrated Dual Permeability Medium** feature to model the transport in an unsaturated dual permeability medium where Richards' Equation ([Equation 4-26](#)) describes the transport in each system.

$$\begin{aligned}
\theta_M \left( \rho \left( S_{c,M} S_{p,M} + \frac{C_{m,M}}{\rho g} \right) \frac{\partial p_M}{\partial t} + \nabla(\rho \mathbf{u}_M) \right) &= -Q_{ip} + \theta_M Q_m \\
(1 - \theta_M) \left( \rho \left( S_{c,m} S_{p,m} + \frac{C_{m,m}}{\rho g} \right) \frac{\partial p_m}{\partial t} + \nabla(\rho \mathbf{u}_m) \right) &= Q_{ip} + (1 - \theta_M) Q_m \\
p &= \theta_M p_M + (1 - \theta_M) p_m
\end{aligned} \tag{5-60}$$

$\theta_M$  is the volume fraction of the macropores,  $Q_{ip}$  is the interporosity flow which is the mass transfer from the macroscale to the microscale system. The indices **M** and **m** stand for macropores and micropores, respectively.

### INTERPOROSITY FLOW

Specify the **Fluid Transfer Function**  $\alpha_w$  which is used to calculate the interporosity flow, which is the mass exchange between macro- and microscale system:

$$Q_{ip} = \alpha_w (p_M - p_m) \tag{5-61}$$

with  $p_M$  being the pressure within the macroscale system and  $p_m$  the pressure within the microscale system

### *References for the Darcy's Law Interface*

1. J. Bear, *Hydraulics of Groundwater*, McGraw Hill, 1979.
2. S.E. Ingebritsen and W.E. Sanford, *Groundwater in Geologic Processes*, Cambridge University Press, 1998.
3. N.H. Sleep and K. Fujita, *Principles of Geophysics*, Blackwell Science, 1997.
4. D.L. Turcotte and G. Schubert, *Geodynamics*, Cambridge University Press, 2002.
5. J. Bear, *Dynamics of Fluids in Porous Media*, Elsevier Scientific Publishing, 1972.
6. Ö. Akgiray and A.M. Saatçı, "A New Look at Filter Backwash Hydraulics," *Water Sci. Technol. Water Supply*, vol. 1, no. 2, pp. 65–72, 2001.
7. L. Klinkenberg, "The permeability of porous media to liquids and gases," *Drilling and Production Practice*, Am. Petroleum Inst., pp. 200–213, 1941.
8. Yu-Shu Wu and others, "Gas Flow in Porous Media with Klinkenberg Effects," *Transp. Porous Media*, vol. 32, pp. 117–137, 1998.
9. B. Ghanbarian and F. Male, "Theoretical power-law relationship between permeability and formation factor," *J. Petrol. Sci. Eng.*, vol. 198, 108249, 2021.

10. H. Gerke and M. van Genuchten, “A dual-porosity model for simulating the preferential movement of water and solutes in structured porous media,” *Water Resour. Res.*, vol. 29, pp. 305–319, 1993.

# Theory for the Free and Porous Media Flow, Brinkman Interface

The [Free and Porous Media Flow, Brinkman Interface](#) uses the Navier–Stokes equations to describe the flow in open regions, and the Brinkman equations to describe the flow in porous regions.

The same fields,  $\mathbf{u}$  and  $p$ , are solved for in both the free flow domains and in the porous domains. This means that the pressure in the free fluid and the pressure in the pores is continuous over the interface between a free flow domain and a porous domain. It also means that continuity is enforced between the fluid velocity in the free flow and the Darcy velocity in the porous domain. This treatment is one of several possible models for the physics at the interface. Examples of other models can be found in [Ref. 1](#).

The continuity in  $\mathbf{u}$  and  $p$  implies a stress discontinuity at the interface between a free-flow domain and a porous domain. The difference corresponds to the stress absorbed by the rigid porous matrix, which is a consequence implicit in the formulations of the Navier–Stokes and Brinkman equations.

## *Reference for the Free and Porous Media Flow, Brinkman Interface*

---

1. M.L. Bars and M.G. Worster, “Interfacial Conditions Between a Pure Fluid and a Porous Medium: Implications for Binary Alloy Solidification,” *J. Fluid Mech.*, vol. 550, pp. 149–173, 2006.

# Theory for the Free and Porous Media Flow, Darcy Interface

The **Free and Porous Media Flow, Darcy** interface uses the Navier–Stokes equations to describe the flow in the free-flow region, implemented by the coupled Laminar Flow interface, and Darcy’s law, implemented by the coupled Darcy’s Law interface, to describe the flow in the porous region.

In the free-flow region, the velocity  $\mathbf{u}$  and pressure  $p$  are solved for, whereas in the porous region only the pressure  $p$  is solved for, and the velocity is calculated from the pressure by Darcy’s law.

The coupling between the free and porous medium flow, implemented by the Free and Porous Media Flow Coupling, ensures conservation of mass across the free-porous interface, which is enforced by the condition

$$\mathbf{n} \cdot (\rho_{\text{ns}} \mathbf{u}_{\text{ns}}) = \mathbf{n} \cdot (\rho_{\text{d}} \mathbf{u}_{\text{d}}) \quad (5-62)$$

Here  $\rho_{\text{ns}}$  and  $\mathbf{u}_{\text{ns}}$  are the density and velocity on the free-flow side of the interface,  $\rho_{\text{d}}$  and  $\mathbf{u}_{\text{d}}$  the density and velocity on the porous side, and  $\mathbf{n}$  is a vector normal to the interface. In addition the coupling enforces the balance of the normal forces by:

$$p_{\text{ns}} - \mathbf{n} \cdot \mathbf{K} \mathbf{n} = p_{\text{d}} \quad (5-63)$$

where  $p_{\text{ns}}$  and  $p_{\text{d}}$  are the pressure on the free-flow side and porous side of the interface, respectively, and  $\mathbf{K}$  is the viscous stress tensor (defined only on the free-flow side). The **Include pressure jump across free-porous boundary** option allows to specify an additional pressure jump  $p_j$ , in order to model, for example, a resistive layer or other pressure losses at the free-porous interface, such that the balance of the normal forces reads:

$$p_{\text{ns}} - \mathbf{n} \cdot \mathbf{K} \mathbf{n} - p_{\text{d}} = p_j \quad (5-64)$$

For the coupling condition for the tangential velocity component, there are several options. One of the most widely used conditions is the **Beavers–Joseph** interface condition ([Ref. 1](#)):

$$(\mathbf{I} - \mathbf{n} \otimes \mathbf{n})(\mathbf{u}_{\text{ns}} - \mathbf{u}_{\text{d}}) = \frac{\sqrt{\text{tr}(\boldsymbol{\kappa})/n}}{\mu_{\text{ns}} \alpha_{BJ}} (\mathbf{I} - \mathbf{n} \otimes \mathbf{n}) \mathbf{K} \mathbf{n} \quad (5-65)$$

where  $a_{BJ}$  is the Beavers and Joseph parameter,  $\kappa$  is the permeability tensor of the porous medium (defined on the porous side of the interface),  $\mu_{ns}$  is the fluid's dynamic viscosity on the free-flow side of the interface, and  $n$  is the number of space dimensions.

When the velocity in the porous domain is much smaller than the velocity in the free flow, one can use a modification of the Beavers–Joseph condition which is given by the **Beavers–Joseph–Saffman** interface condition (Ref. 2):

$$(\mathbf{I} - \mathbf{n} \otimes \mathbf{n})\mathbf{u}_{ns} = \frac{\sqrt{\text{tr}(\kappa)/n}}{\mu_{ns}\alpha_{BJ}}(\mathbf{I} - \mathbf{n} \otimes \mathbf{n})\mathbf{K}\mathbf{n} \quad (5-66)$$

For cases when the permeability tensor is not isotropic, the **Use projected permeability** option allows to take into account only the permeability in the direction of the tangential velocity component. This is accomplished by replacing the  $\sqrt{\text{tr}(\kappa)/n}$  term on the rights hand side of Equation 5-65 and Equation 5-66 by

$$\sqrt{\mathbf{t} \cdot \kappa \mathbf{t}} \quad (5-67)$$

with  $\mathbf{t}$  a unit vector tangent to the interface for 2D and 2D-axisymmetric cases, and for 3D cases by

$$\sqrt{\mathbf{v} \cdot \kappa \mathbf{v}} \quad (5-68)$$

with  $\mathbf{v}$  given by

$$\mathbf{v} = \frac{(\mathbf{I} - \mathbf{n} \otimes \mathbf{n})\mathbf{K}\mathbf{n}}{\|(\mathbf{I} - \mathbf{n} \otimes \mathbf{n})\mathbf{K}\mathbf{n}\|} \quad (5-69)$$

If one considers the limit of the Beavers–Joseph condition for large values of the Beavers and Joseph parameter  $a_{BJ}$ , one obtains the **Continuous tangential velocity** condition:

$$(\mathbf{I} - \mathbf{n} \otimes \mathbf{n})(\mathbf{u}_{ns} - \mathbf{u}_d) = 0 \quad (5-70)$$

The same limit for the Beavers–Joseph–Saffman condition results in the **No slip** condition:

$$(\mathbf{I} - \mathbf{n} \otimes \mathbf{n})\mathbf{u}_{ns} = 0 \quad (5-71)$$

The **Viscous slip** condition allows for a more general coupling condition. This interface condition is given by

$$(\mathbf{I} - \mathbf{n} \otimes \mathbf{n})(\mathbf{u}_{\text{ns}} - \mathbf{u}_b) = \frac{L_s}{\mu_{\text{ns}}}(\mathbf{I} - \mathbf{n} \otimes \mathbf{n})\mathbf{K}\mathbf{n} \quad (5-72)$$

Here  $L_s$  is a slip length, and  $\mathbf{u}_b$  a user-defined interfacial velocity.



Please find related information in the *CFD Module User's Guide*:

- [The Darcy's Law Interface](#)
- [The Thin-Film and Porous Media Flow Interface](#)
- [The Laminar Flow Interface](#)
- [Theory for the Single-Phase Flow Interfaces](#)

### *References*

1. G.S. Beavers and D.D. Joseph, "Boundary Conditions at a Naturally Permeable Wall," *J. Fluid Mech.*, vol. 30, 1967.
2. P.G. Saffman, "On the Boundary Condition at the Surface of a Porous Medium," *Stud. Appl. Math.*, vol. 50, no. 2, pp. 93–101, 1971.

# Theory for the Brinkman Equations Interface

The [Brinkman Equations Interface](#) theory is described in this section:

- [About the Brinkman Equations](#)
- [Brinkman Equations Theory](#)
- [References for the Brinkman Equations Interface](#)

## *About the Brinkman Equations*

---

In porous domains, the flow variables and fluid properties are defined at any point inside the medium by means of averaging of the actual variables and properties over a certain volume surrounding the point. This control volume must be small compared to the typical macroscopic dimensions of the problem, but it must be large enough to contain many pores and solid matrix elements.

Porosity is defined as the fraction of the control volume that is occupied by pores. Thus, the porosity can vary from zero for pure solid regions to unity for domains of free flow.

The physical properties of the fluid, such as density and viscosity, are defined as *intrinsic volume averages* that correspond to a unit volume of the pores. Defined this way, they present the relevant physical parameters that can be measured experimentally, and they are assumed to be continuous with the corresponding parameters in the adjacent free flow.

The flow velocity is defined as a *superficial volume average*, and it corresponds to a unit volume of the medium including both the pores and the matrix. It is sometimes called the Darcy velocity, defined as the volume flow rate per unit cross section of the medium. Such a definition makes the velocity field continuous across the boundaries between porous regions and regions of free flow.

## *Brinkman Equations Theory*

---

The dependent variables in the Brinkman equations are the Darcy velocity and the pressure. The flow in porous media is governed by a combination of the continuity equation and the momentum equation, which together form the Brinkman equations:

$$\frac{\partial}{\partial t}(\epsilon_p \rho) + \nabla \cdot (\rho \mathbf{u}) = Q_m \quad (5-73)$$

$$\frac{\rho}{\epsilon_p} \left( \frac{\partial \mathbf{u}}{\partial t} + (\mathbf{u} \cdot \nabla) \frac{\mathbf{u}}{\epsilon_p} \right) = -\nabla p + \nabla \cdot \left[ \frac{1}{\epsilon_p} \left\{ \mu (\nabla \mathbf{u} + (\nabla \mathbf{u})^T) - \frac{2}{3} \mu (\nabla \cdot \mathbf{u}) \mathbf{I} \right\} \right] - \left( \kappa^{-1} \mu + \frac{Q_m}{\epsilon_p^2} \right) \mathbf{u} + \mathbf{F} \quad (5-74)$$

In these equations:

- $\mu$  (SI unit: kg/(m·s)) is the dynamic viscosity of the fluid
- $\mathbf{u}$  (SI unit: m/s) is the velocity vector
- $\rho$  (SI unit: kg/m<sup>3</sup>) is the density of the fluid
- $p$  (SI unit: Pa) is the pressure
- $\epsilon_p$  is the porosity
- $\kappa$  (SI unit: m<sup>2</sup>) is the permeability of the porous medium, and
- $Q_m$  (SI unit: kg/(m<sup>3</sup>·s)) is a mass source or sink

Influence of gravity and other volume forces can be accounted for via the force term  $\mathbf{F}$  (SI unit: kg/(m<sup>2</sup>·s<sup>2</sup>)).

When the **Neglect inertial term (Stokes flow)** checkbox is selected, the term  $(\mathbf{u} \cdot \nabla)(\mathbf{u}/\epsilon_p)$  on the left-hand side of [Equation 5-74](#) is disabled.

The mass source,  $Q_m$ , accounts for mass deposit and mass creation within the domains. The mass exchange is assumed to occur at zero velocity.

The Forchheimer and Ergun drag options add a viscous force proportional to the square of the fluid velocity,  $\mathbf{F} = -\rho\beta|\mathbf{u}|\mathbf{u}$ , on the right-hand side of [Equation 5-74](#); see [References for the Darcy's Law Interface](#) for details.

In case of a flow with variable density, [Equation 5-73](#) and [Equation 5-74](#) must be solved together with the equation of state that relates the density to the temperature and pressure (for instance the ideal gas law).

For incompressible flow, the density stays constant in any fluid particle, which can be expressed as

$$\frac{\partial}{\partial t}(\epsilon_p \rho) + \mathbf{u} \cdot \nabla \rho = 0$$

and the continuity equation (Equation 5-73) reduces to

$$\rho \nabla \cdot \mathbf{u} = Q_m$$

*References for the Brinkman Equations Interface*

---

1. D. Nield and A. Bejan, *Convection in Porous Media*, 3rd ed., Springer, 2006.
2. M. Le Bars and M.G. Worster, “Interfacial Conditions Between a Pure Fluid and a Porous Medium: Implications for Binary Alloy Solidification,” *J. Fluid Mech.*, vol. 550, pp. 149–173, 2006.

# Theory for the Coupling of Fluid Flow to Electrochemical Reactions

This section briefly discusses [Momentum Sources and Sinks](#). Also see [Theory for the Coupling of Mass Transport to Electrochemical Reactions](#) for how to calculate molar and mass fluxes, sources, and sinks.

## *Momentum Sources and Sinks*

---

The flow velocity,  $\mathbf{u}$  (SI unit: m/s), at a boundary is coupled to the total mass flux of the species at the electrode surface in the following way

$$\mathbf{u} \cdot \mathbf{n} = \frac{1}{\rho} \sum_i \mathbf{n}_i \cdot \mathbf{n} \quad (5-75)$$

where  $\rho$  (SI unit: kg/m<sup>3</sup>) is the density of the flowing media,  $\mathbf{n}$  the surface normal and  $\mathbf{n}_i$  is the mass flux of species  $i$ .

For flow interfaces solving for the velocity field, no-slip conditions are applied at the electrode surface, resulting in

$$\mathbf{u} = -\left(\frac{1}{\rho} \sum_i M_i N_i\right) \mathbf{n} \quad (5-76)$$

where  $M_i$  (SI unit: kg/mol) is the species mass and  $N_i$  (SI unit: mol/(m<sup>2</sup>·s)) the molar flux calculated by Faraday's law.

For a porous electrode the sum of all mass fluxes are added to the conservation equation according to:

$$\frac{\partial \rho}{\partial t} + \nabla \cdot (\rho \mathbf{u}) = \sum_i R_{i, \text{mass}} \quad (5-77)$$

Note that because the mass is usually not conserved within the species transporting phase (the right-hand side above being nonzero), the velocity field is not divergence free.



## Heat Transfer

As with all other physical descriptions simulated by COMSOL Multiphysics, any description of heat transfer can be directly coupled to any other physical process. This is particularly relevant for systems based on chemical reactions and mass transfer along with fluid flow. These physics interfaces are found under the **Heat Transfer** branch (  ).

The basic functionality for simulating heat transfer in homogeneous media is described in [Heat Transfer](#) in the *COMSOL Multiphysics Reference Manual*. The Electrochemistry Module also provides extra functionality for simulating heat transfer in porous media. The documentation [The Heat Transfer in Porous Media Interface](#) is found in the *Heat Transfer Module User's Guide*, which is supplied with the Electrochemistry Module irrespective of whether a separate Heat Transfer Module license is purchased.

Most electrochemistry interfaces automatically define heat source variables that may be coupled to the heat transfer interfaces either manually or by the use of a [Electrochemical Heating](#) multiphysics node. See the [Theory for Electrochemical Heat Sources](#) section in the [Electrochemistry Interfaces](#) chapter for more information on how these heat source variables are computed.







# Multiphysics Coupling Nodes

The Electrochemistry Module has multiphysics couplings available under certain conditions.

When a predefined multiphysics interface is added from the **Model Wizard** or **Add Physics** windows, it adds the constituent interfaces and the **Multiphysics Couplings** node, which automatically includes one or more multiphysics couplings.

If the constituent physics interfaces are added one at a time, then it adds an empty **Multiphysics Couplings** node. When you right-click this node, you can choose from the available multiphysics couplings.



The [Multiphysics Branch](#) in the *COMSOL Multiphysics Reference Manual*.

---

In this chapter, the following multiphysics couplings nodes are described:

- [Electrochemical Heating](#)
- [Space Charge Density Coupling](#)
- [Potential Coupling](#)

## *Electrochemical Heating*

---

Use the **Electrochemical Heating** multiphysics coupling () to define domain and boundary heat sources in a heat transfer interface, based on the sum of irreversible (Joule heating and activation losses) and reversible heat in an electrochemistry interface. The node also defines the temperature in the electrochemistry interface to be equal to that of the heat transfer interface.

The settings of this node are similar to the **Electromagnetic Heating** node, described in the *COMSOL Multiphysics Reference Manual*.



### Theory for Electrochemical Heat Sources

---

## *Potential Coupling*

---

The **Potential Coupling** multiphysics coupling () applies the electrolyte potential variable from the source interface into the model inputs of the destination interface. The potential variable is typically used to compute the migration flux in the destination interface.

### **COUPLED INTERFACES**

Specify the physics interface that provides the potential (Electrostatics, for instance) in the **Source** list and the Chemical Species Transport interface in the **Destination** list.

## *Space Charge Density Coupling*

---

The **Space Charge Density Coupling** multiphysics coupling () computes the local space charge based on local concentrations and species charges in a Chemical Species Transport interface. The computed space charge is then added as a contribution to the Poisson equation in an Electrostatics interface. The charge is added in the same way as a Space Charge Density feature does.

### **COUPLED INTERFACES**

Specify the Chemical Species Transport interface in the **Source** list and the Electrostatics interface in the **Destination** list.





## Glossary

This [Glossary of Terms](#) contains application-specific terms used in the Electrochemistry Module software and documentation. For finite element modeling terms, mathematical terms, and geometry and CAD terms, see the glossary in the *COMSOL Multiphysics Reference Manual*. For references to more information about a term, see the index.

# Glossary of Terms

**anode** An [electrode](#) where [oxidation](#) occurs. Anodic charge transfer current densities and overpotentials are positive by definition.

**cathode** An [electrode](#) where [reduction](#) occurs. Cathodic charge transfer current densities and overpotentials are negative by definition.

**cell voltage** The difference in potential over an electrochemical cell.

**charge transfer reaction** A reaction during which charge is transferred from an electron conducting phase (electrode) to an ion conducting phase (electrolyte).

**charge transfer current density** The current density at an electrolyte-electrode interface associated with a [charge transfer reaction](#).

**concentrated electrolyte** An [electrolyte](#) where the concentration of charged species is so high that the interactions (friction forces) between the ions needs to be considered. See also [diluted electrolyte](#).

**current collector** A part of an electrochemical device with high electric conductivity for conducting current out of the cell. See also [current feeder](#).

**current feeder** A part of an electrochemical device with high electric conductivity for conducting current into the cell. See also [current collector](#).

**diluted electrolyte** An [electrolyte](#) where the charged species are diluted in a solvent so that the interaction between the ions can be neglected. See also [concentrated electrolyte](#).

**electric potential** The potential in the electrode (electron conducting) phase, denoted  $\phi_s$  (phis).

**electrode** An electron conductor.

**electrode reaction** See [charge transfer reaction](#).

**electrokinetic flow** Transport of fluid or charged particles within a fluid by means of electric fields.

**electrolyte** An ion conductor.

**electrolyte potential** The potential in the electrolyte (ionic) phase, denoted  $\phi_l$  (phil).

**electroneutrality** A situation where the net charge of any small control volume of a domain is zero. Electroneutrality can usually be assumed for electrolytes, with an exception for the very proximity of the electrolyte-electrode interface, which is due to the charge separation within the electrochemical double layer.

**equilibrium potential** The potential difference between the electrode and electrolyte at which the net current density of an [electrode reaction](#) is zero.

**Faraday's Law** A mathematical expression relating the flux of a species over an electrode-electrolyte interphase to be proportional to the charge transfer current density.

**gas diffusion electrode (GDE)** A [porous electrode](#) that also includes gas pores in the porous matrix.

**GDE** See [gas diffusion electrode \(GDE\)](#).

**Gibbs free energy** A thermodynamic potential that depends on the enthalpy and entropy of the reacting species.

**intrinsic volume averages** The physical properties of the fluid, such as density, viscosity, and pressure.

**intercalation** The process of ions reacting on the surface of a host particle to form a solid, intercalated, species within the host. The intercalated species can then be transported further into the particle by diffusion processes.

**migration** The transport of charged species in an electrolyte due to the electric force imposed by the electric field.

**morphology correction parameter** A correction parameter that is used to account for morphology effects of a porous structure.

**Nernst–Planck equation** A commonly used equation for describing the transport of charged species in a [diluted electrolyte](#). The equation includes transport due to diffusion, [migration](#) and convection. The Nernst–Planck equation can be modeled in

COMSOL Multiphysics using the Tertiary Current Distribution, Nernst–Planck interface (and the Transport of Diluted Species interface). The Nernst–Planck equation is often combined with an electroneutrality condition.

**Nernst–Planck–Poisson equation** In certain situations, for instance when striving to resolve the electrochemical double layer at an electrode, and [electroneutrality](#) cannot be assumed, the [Nernst–Planck equation](#) is combined with the [Poisson’s equation](#) for describing the charge density.

**overpotential** A deviation from the [equilibrium potential](#).

**oxidation** A [charge transfer reaction](#) where electrons are produced.

**perfectly mixed electrolyte.** An electrolyte where no concentration gradients are present, for instance due to stirring. See also [secondary current distribution](#).

**primary current distribution** The current distribution that is established when overpotentials can be neglected — that is, when the current distribution is governed by the electrolyte and electrode conductivities only. See also [secondary current distribution](#) and [tertiary current distribution](#).

**Poisson’s equation** An equation for relating the electric field to the space charge density. Can be modeled in COMSOL using the Electrostatics interface.

**pore electrolyte** An electrolyte in the pores of a porous matrix. See [porous electrode](#).

**porous electrode** A porous matrix containing both electron conducting and ion conducting media.

**potentiostat** A device that monitors and controls the potential of an electrode versus a [reference electrode](#).

**reduction** A charge transfer reaction where electrons are consumed.

**reference electrode** An electrode used for reference when defining the potentials of the electrodes in a cell. A good reference electrode is stable and does not vary in potential. Typically no net reactions occur at a reference electrode surface, and the net current density is zero.

**resistive film** A film with ohmic resistivity, typically formed as a result of electrode reactions.

**secondary current distribution** The current distribution that is established when concentration overpotentials can be neglected — that is, when the current distribution is governed by the activation overpotentials and the electrolyte conductivity. See also [tertiary current distribution](#) and [primary current distribution](#). Note that COMSOL models using the Secondary Current Distribution interface can in fact be modeling a [tertiary current distribution](#) because mass transport activation losses can be present in the electrode reaction current density expressions.

**solid-electrolyte interphase (SEI)** A resistive and passivating layer formed on the graphite electrode particles in the negative electrode of a lithium-ion battery.

**stoichiometric coefficients** The number of species reacting in a reaction formula. In a redox reaction the oxidized species have negative sign and the reduced species have positive sign by convention.

**superficial volume averages** The flow velocities, which correspond to a unit volume of the medium including both pores and matrix. These are sometimes called Darcy velocities, defined as volume flow rates per unit cross section of the medium.

**supporting electrolyte** An electrolyte with an excess of charge carriers so that the conductivity can be assumed not to be affected by the currents flowing in the cell.

**surface molar flux** The tangential flux in the surface dimension as governed by diffusion according to Fick's law.

**tertiary current distribution** The current distribution that is established when concentration overpotentials cannot be neglected — that is, when the current distribution is governed by the activation and concentration overpotentials, as well as the electrolyte conductivity. The electrolyte conductivity can also be nonconstant due to the currents flowing in the cell. See also [secondary current distribution](#) and [primary current distribution](#).



# I n d e x

- A**
  - absolute pressure 338, 439
  - activation overpotential 147, 154, 193
  - adsorption 240
  - amperometric sensing 190
  - analyte 190
  - anodes 32
  - anodic Tafel equation 157
  - anodic transfer coefficient 148
  - Application Libraries window 25
  - application library examples
    - convection and diffusion 216
    - Darcy's law 362
    - laminar flow 336
    - migration in electric field 216
    - secondary current distribution 64
    - storage model 407
    - transport of diluted species 210
  - aqueous electrolyte transport interface
    - 111
  - Arrhenius parameters 258
  - atmosphere/gauge (node) 401
  - average linear velocity 480
  - average pressure (node) 356
- B**
  - boundary current source (node) 140
  - boundary electrolyte potential 99, 127, 284
  - boundary nodes
    - Brinkman equations 431
    - Darcy's law interface 362
    - electrochemistry interfaces 82
    - electrode, shell 137
    - free and porous media flow 414
    - surface reactions 288
    - transport of diluted species 116, 211, 279
  - boundary stress (node) 350
- Brinkman equations** 488
- Brinkman equations interface** 427
  - theory 488
- Butler–Volmer and Tafel expressions**
  - tertiary current distribution 71
- Butler–Volmer equation** 41
  - electroanalysis 195
  - electrode kinetics 154
  - secondary current distribution 147
- C**
  - cathodes 32
  - cathodic charge transfer coefficient 148
  - cathodic Tafel equation 157
  - CFL number
    - settings 335, 431
  - charge transfer reaction 147
  - charge transfer reactions 92
  - checklist, for modeling 51
  - chemical equilibrium 256
  - chronoamperometry 190
  - common settings 22
  - concentration (node)
    - transport of diluted species 221
  - contributing velocity (node)
    - Darcy's law 383
  - convection 304
  - coulometry 190
  - creeping flow (spf) interface 330
  - current (node) 283
  - current conductor (node)
    - electrochemistry 84
  - current density (node) 283
  - current source (node) 139
  - cyclic voltammetry 190
- D**
  - Darcy velocity 304, 393
  - Darcy's law interface 360

- Darcy's law interface theory 477
- Debye length 36
- documentation 24
- domain nodes
  - Brinkman equations 431
  - Darcy's law 362
  - electrochemistry interfaces 82
  - electrophoretic transport interface
    - 116, 279
  - free and porous media flow 414
  - transport of diluted species 211
- double-layer capacitance (node) 97
- E**
  - edge electrode (node) 67
  - edge nodes
    - Darcy's law interface 362
    - electrochemistry interfaces 82
    - electrode, shell 137
    - surface reactions 288
  - electric insulation (node)
    - electrode, shell 140
  - electric potential (node)
    - electrode, shell 141
  - electric reference potential (node) 106
  - electroanalysis interface 142
    - theory 190
  - electroanalysis, definition 190
  - electrochemical cells 32
  - electrochemical impedance spectroscopy (EIS) 190
  - electrochemical sensing 190
  - electrode 146
  - electrode (node)
    - electrode, shell 138
  - electrode current (node) 103
  - electrode current density (node) 103
  - electrode current source (node) 84
  - electrode line current source (node) 68
  - electrode points current source (node)
    - 69
  - electrode potential (node) 105
  - electrode power (node) 104
  - electrode reaction (node)
    - electrochemistry 92
  - electrode surface (node) 87
  - electrode symmetry axis current source
    - (node) 69
  - electrode, shell interface 136
    - theory 188
  - electrode–electrolyte boundary interface (node)
    - current distribution 101
  - electrode–electrolyte interface coupling
    - (node)
      - free and porous media flow 388, 421
      - transport of diluted species 233
  - electrode–electrolyte interfaces 32
  - electrodes 31
  - electrolysis 31
  - electrolyte 146
  - electrolyte (node)
    - primary and secondary current distribution 64
    - tertiary current distribution 76
  - electrolyte current (node) 100
  - electrolyte current density (node) 100
  - electrolyte current source (node) 85
  - electrolyte line current source (node) 68
  - electrolyte points current source (node)
    - 70
  - electrolyte potential 149
  - electrolyte potential (node) 99
  - electrolyte symmetry axis current
    - source (node) 69
  - electrolytes 31
  - electromagnetic heat source (multiphysics coupling) 498

- electroneutrality 36
  - electrophoretic transport interface 273
  - electrophoretic transport 273
  - elevation 386
  - emailing COMSOL 25
  - equilibrium potential 147
  - Equilibrium Reaction
    - theory for 294
  - equilibrium reaction (node) 229
  - equilibrium reaction group (node) 269
  - external short (node) 105
- F**
- faradaic current 45
  - Faraday's constant 148
  - Faraday's law 300
  - Faraday's laws of electrolysis 194
  - Fick diffusion laws 192
  - flow continuity (node) 354
  - flow rate in SCCMs 345
  - fluid flow
    - Brinkman equations theory 488
  - flux (node) 127, 285
    - transport of diluted species 127, 222, 285
  - flux discontinuity (node) 223
    - Darcy's law 396
    - transport of diluted species 223
  - fracture flow (node) 404
  - free and porous media flow interface 411
    - theory 484
  - Freundlich exponent 310
  - fully developed flow 345
- G**
- galvanic cells 31
  - gas reacting fluids 250, 264
  - general stress (boundary stress condition) 351
  - Gibbs free energy 260
  - gravity 358
  - ground (node) 140
- H**
- harmonic perturbation (node) 104
  - heterogeneous rate constant 195
  - highly conductive porous electrode (node)
    - electrochemistry 84
  - hydraulic head (node) 401
  - Hygroscopic Swelling 244
- I**
- inflow (node) 128, 220, 286
  - initial values (node)
    - Brinkman equations 438
    - Darcy's law 384
    - electrode, shell 139
    - for adsorbing-desorbing species 106
    - free and porous media flow 420
    - primary and secondary current distribution 65
    - single-phase, laminar flow 339
    - spf interfaces 339
    - surface reactions 290
    - tertiary current distribution 78
    - transport of diluted species 217
  - inlet (node) 342
    - single-phase flow 342
  - insulation (node) 87, 283
  - internal electrode surface (node) 98
  - internet resources 23
  - intrinsic volume averages 488
  - ion-exchange membrane (node) 79
  - ion-exchange membrane boundary (node) 80
  - irreversible reaction 256
- K**
- knowledge base, COMSOL 26
- L**
- laminar flow interface 331
  - Langmuir constant 310
  - leaking wall, wall boundary condition 341, 422
  - line mass source (node)

- fluid flow 357
  - species transport 226
- line source
  - species transport 298
- liquid reacting fluids 250, 264
- load cycle (node) 106
- local
  - CFL number 335, 431
- M** mass based concentrations (node) 217
- mass source (node)
  - Brinkman equations 437
  - Darcy's law 383
- modeling checklist 51
- monolayer adsorption 322
- MPH files 25
- multiphysics couplings
  - electromagnetic heat source (node) 498
- N** Nernst equation 195
- Nernst–Einstein relation 215, 236, 240, 300
- Nernst–Planck equations 35, 144
- Nernst–Planck–Poisson equations 36
- Nernst–Planck–Poisson Equations interface 271
- no flow (node) 395
- no flux (node) 219
- no slip, wall boundary condition 340, 422
- no viscous stress (open boundary) 350
- nodes, common settings 22
- nonconservative formulations 296
- normal current density (node) 140
- normal stress, normal flow (boundary stress condition) 351
- O** Ohm's law 61, 146, 301
  - ohmic drop 191
  - open boundary (node)
    - single-phase flow 349
    - spf interfaces 349
    - transport of diluted species 228
- outflow (node)
  - electrophoretic transport 128, 286
  - transport of diluted species 221
- outlet (node) 346
  - single-phase flow 346
  - spf interfaces 346
- overpotential 40, 147
- P** pair nodes
  - Brinkman equations 431
  - Darcy's law interface 362
  - electrochemistry interfaces 82
  - electrode, shell 137
  - electrophoretic transport interface 116, 279
  - free and porous media flow 414
  - surface reactions 288
  - transport of diluted species 211
- partially saturated porous media (node) 237
- perforated electrode surface (node) 98
- periodic condition (node) 66
  - transport of diluted species 225
- periodic flow condition (node) 352
- permeability models 369, 379, 409
- pervious layer (node) 402
- physics interfaces, common settings 22
- point mass source (node)
  - fluid flow 356
  - species transport 227
- point nodes
  - Brinkman equations 431
  - Darcy's law interface 362
  - electrochemistry interfaces 82
  - electrode, shell 137
  - free and porous media flow 414

- surface reactions 288
  - transport of diluted species 211
- point source
  - species transport 297
- porous electrode (node) 65, 77
- porous electrode coupling (node) 232
  - free and porous media flow 387, 419
- porous electrode reaction (node) 85
- porous electrodes 64, 147
- porous matrix double-layer capacitance (node) 86
- porous media and subsurface flow
  - Brinkman equations interface 427
  - Darcy's law interface 360
  - free and porous media flow interface 411
  - theory, Brinkman equations 488
  - theory, free and porous media flow 484
- porous media transport properties (node) 233, 237
- Porous Medium (node)
  - Brinkman equations 416, 432
- potential (node) 127, 284
- potentiometry 190
- potentiostat 198
- pressure (node) 389, 393, 397
- pressure head (node) 400
- pressure point constraint (node) 355
- primary current distribution 33
- primary current distribution interface 61
  - theory 143
- pseudo time stepping
  - settings 335, 431
- R** reacting fluids, gases and liquids 250, 264
- Reacting Volume 218
- reaction (node) 254
- reaction coefficients (node) 232
- reactions (node)
  - surface reactions 290
  - tertiary current distribution 78
  - transport of diluted species 218
- reference electrode (node) 106
- resistive film 153
- retardation factor 310
- reversible reaction 256
- reversible reaction group (node) 267
- rotating frame 358
- S** SCCM, flow rate in 345
- secondary current distribution 33
- secondary current distribution interface 61
  - theory 143
- SEMI standard E12-0303 344
- separator (node)
  - current distribution 78
- single-phase flow interface
  - laminar flow 331
- sliding wall 342
- slip, wall boundary condition 341, 422
- species (node) 262
- species activity (node) 270
- species group (node) 270
- species source (node) 284
- species thermodynamics (node) 270
- standard cubic centimeters per minute 345
- standard flow rate 345
- standard settings 22
- stoichiometric coefficients 260
- Stokes equations 330
- Stokes flow 330
- stratified porous media 308
- study types
  - physics interface availability 22
- superficial volume average, porous me-

- dia 488
  - superficial volume averages, porous media 304
  - supporting electrolyte 190
  - Supporting Electrolytes 300
  - surface concentration (node) 291
  - surface equilibrium reaction (node) 231
  - surface properties (node) 289
  - surface reactions interface 287
    - theory 321
  - symmetry (node) 349
    - Darcy's law 395
    - electrochemistry 87
    - spf interfaces 349
    - transport of diluted species 223
- T**
- Tafel equation 157
  - Tafel law 41
  - technical support, COMSOL 25
  - tertiary current distribution 33
  - tertiary current distribution interface
    - theory 143
  - tertiary current distribution, Nernst–Planck interface 71
  - theory
    - Brinkman equations 488
    - electroanalysis interface 190
    - electrode, shell interface 188
    - free and porous media flow 484
    - primary current distribution interface 143
    - secondary current distribution interface 143
    - surface reactions 321
    - tertiary current distribution interface 143
    - transport of diluted species in porous media interface 293
    - transport of diluted species interface 292
  - thickness
    - fracture 247
    - out-of-plane 387
  - thin diffusion barrier (node) 228
  - thin electrode layer (node) 100
  - thin electrode surface (node) 99
  - thin electrolyte layer (node) 80
  - Thin Impermeable Barrier 228
  - tortuosity factors 306
  - traction boundary conditions 350
  - transport of diluted species in porous media interface 210
    - theory 293
  - transport of diluted species interface 206
    - theory 292
- V**
- voltammetry, cyclic 190
  - volume averages 488
  - volume force (node) 339, 437
    - free and porous media flow 419
    - spf interfaces 339
- W**
- wall (node)
    - free and porous media flow 422
    - single-phase flow 340
  - websites, COMSOL 26