

# Composite Materials Module

User's Guide

# Composite Materials Module User's Guide

© 1998–2025 COMSOL

Protected by patents listed on [www.comsol.com/patents](http://www.comsol.com/patents), or see Help > About COMSOL Multiphysics on the File menu in the COMSOL Desktop for less detailed lists of U.S. Patents that may apply. Patents pending.

This Documentation and the Programs described herein are furnished under the COMSOL Software License Agreement ([www.comsol.com/sla](http://www.comsol.com/sla)) and may be used or copied only under the terms of the license agreement.

COMSOL, the COMSOL logo, COMSOL Multiphysics, COMSOL Desktop, COMSOL Compiler, COMSOL Server, and LiveLink are either registered trademarks or trademarks of COMSOL AB. All other trademarks are the property of their respective owners, and COMSOL AB and its subsidiaries and products are not affiliated with, endorsed by, sponsored by, or supported by those trademark owners. For a list of such trademark owners, see [www.comsol.com/trademarks](http://www.comsol.com/trademarks).

Version: COMSOL 6.4

## Contact Information

Visit the Contact COMSOL page at [www.comsol.com/contact](http://www.comsol.com/contact) to submit general inquiries or search for an address and phone number. You can also visit the Worldwide Sales Offices page at [www.comsol.com/contact/offices](http://www.comsol.com/contact/offices) for address and contact information.

If you need to contact Support, an online request form is located on the COMSOL Access page at [www.comsol.com/support/case](http://www.comsol.com/support/case). Useful links:

- Support Center: [www.comsol.com/support](http://www.comsol.com/support)
- Product Download: [www.comsol.com/product-download](http://www.comsol.com/product-download)
- Product Updates: [www.comsol.com/product-update](http://www.comsol.com/product-update)
- COMSOL Blog: [www.comsol.com/blogs](http://www.comsol.com/blogs)
- Discussion Forum: [www.comsol.com/forum](http://www.comsol.com/forum)
- Events: [www.comsol.com/events](http://www.comsol.com/events)
- COMSOL Video Gallery: [www.comsol.com/videos](http://www.comsol.com/videos)
- Support Knowledge Base: [www.comsol.com/support/knowledgebase](http://www.comsol.com/support/knowledgebase)
- Learning Center: [www.comsol.com/support/learning-center](http://www.comsol.com/support/learning-center)

Part number: CM024701

# C o n t e n t s

## Chapter 1: The Composite Materials Module

<b>About the Composite Materials Module</b>	<b>9</b>
What Can the Composite Materials Module Do? . . . . .	9
Where Do I Access the Documentation and Application Libraries? . . . . .	10

## Chapter 2: Composite Materials Modeling

<b>About Composite Materials</b>	<b>16</b>
Classification of Composites . . . . .	16
Fiber-Reinforced Polymer (FRP) Composites . . . . .	17
Benefits of Composites . . . . .	18
Challenges of Composites . . . . .	18
<b>About Laminated Composite Shells</b>	<b>19</b>
Reinforcement Arrangement . . . . .	19
Stacking Sequence . . . . .	20
Types of Laminates . . . . .	21
Analysis on Different Scales . . . . .	21
<b>Micromechanics Modeling</b>	<b>23</b>
Constituents of a Lamina . . . . .	23
Parts for Micromechanical Analysis . . . . .	24
Homogenization and Cell Periodicity . . . . .	24
<b>Macromechanics Modeling</b>	<b>26</b>
<b>Laminated Shell Theories</b>	<b>28</b>
Equivalent Single Layer (ESL) Theory . . . . .	28
Layerwise (LW) Theory . . . . .	30
Selection of an Appropriate Laminate Theory . . . . .	31

<b>Layered Membrane</b>	<b>33</b>
<b>Thin Layers</b>	<b>34</b>
<b>Layered Materials</b>	<b>35</b>
Defining a Layered Material . . . . .	35
Connecting a Layered Material to the Physical Geometry . . . . .	38
Defining a Laminate Coordinate System . . . . .	39
Defining a Layer Local System . . . . .	42
Defining a Layered Material Stack . . . . .	45
Defining Variable Thickness Layers . . . . .	46
Ply-Based Modeling Approach . . . . .	47
Saving and Loading Layered Material . . . . .	49
Sweep over Layered Materials . . . . .	49
Sensitivity Analysis of Layered Materials . . . . .	50
Visualizing 3D Geometry and Fiber Draping. . . . .	50
<b>Layer and Interface Selections</b>	<b>52</b>
<b>Failure Modeling</b>	<b>58</b>
Failure Analysis . . . . .	58
Buckling Analysis . . . . .	59
Delamination Modeling . . . . .	59
<b>Structural Couplings</b>	<b>61</b>
Layered Shell — Shell Connection . . . . .	61
Layered Shell — Structure Cladding . . . . .	61
Layered Shell — Structure Transition . . . . .	61
<b>Multiphysics Modeling</b>	<b>62</b>
Coupling to Electrical and Thermal Modeling . . . . .	62
Coupling to Fluid and Acoustics Modeling . . . . .	62
Coupling to Darcy's Law for Poroelasticity Modeling . . . . .	63
Coupling to Lumped Mechanical System Modeling . . . . .	63
<b>Results Evaluation</b>	<b>64</b>
Layered Material Dataset. . . . .	64
Layered Material Slice Plot . . . . .	67

Through Thickness Plot . . . . .	68
Special Variables and Operators . . . . .	69



# The Composite Materials Module

The Composite Materials Module is an optional add-on package for COMSOL Multiphysics<sup>®</sup> designed to assist you in modeling structural behavior that includes layered shells. The module is an add-on to the Structural Mechanics Module. The module is designed for researchers, engineers, teachers, and students who want to simulate the behavior of layered structures.

The Composite Materials Module provides the following extensions:

- The Layered Shell physics interface
- The Linear Elastic Material, Layered, the Hyperelastic Material, Layered, and the Piezoelectric Material, Layered material models in the Shell interface
- The Linear Elastic Material, Layered material model in the Membrane interface
- Multilayered functionality in the Thin Layer feature in the Solid Mechanics interface
- The Thermal Stress, Layered Shell multiphysics interface
- The Piezoelectricity, Layered Shell multiphysics interface (requires also the AC/DC or MEMS modules)
- The Piezoresistivity, Layered Shell multiphysics interface (requires also the AC/DC or MEMS modules)

- The Poroelasticity, Layered Shell multiphysics interface (requires also the Porous Media Flow module)
- The Layered Shell–Structure Transition, Layered Shell–Structure Cladding, and Layered Shell–Shell Connection multiphysics couplings to connect the Layered Shell interface with other structural interfaces
- Acoustic–Structure Boundary, Porous–Structure Boundary, Thermoviscous Acoustic–Structure Boundary, and Aeroacoustic–Structure Boundary multiphysics couplings to connect the Layered Shell interface with acoustics interfaces (requires also the Acoustics module).
- Fluid–Structure Interaction multiphysics coupling to connect the Layered Shell interface with fluid interfaces (requires also the CFD module).
- Lumped–Structure Connection to connect the Layered Shell interface with the Lumped Mechanical Systems interface (requires also the Multibody Dynamics module).
- The Layered Material node under global materials, in which you specify the layup of a stacked material. The Layered Material Stack node under materials.



The Linear Elastic Material, Layered in the Shell and Membrane interfaces is also available with the Structural Mechanics Module. However, its usage is then restricted to a single layer material. In that context, is mainly intended for modeling using nonlinear material models in the Shell interface and multiphysics couplings in the Shell and Membrane interfaces.

The Hyperelastic Material, Layered in the Shell interface is available with Nonlinear Materials Module. The Piezoelectric Material, Layered in the Shell interface is available with AC/DC or MEMS modules.

# About the Composite Materials Module

In this section:

- [What Can the Composite Materials Module Do?](#)
- [Where Do I Access the Documentation and Application Libraries?](#)

## *What Can the Composite Materials Module Do?*

---

Using the Composite Materials Module, a laminated composite shell, also known as composite laminate, can be modeled. A composite laminate is an assembly of layers with different mechanical properties. The laminate is designed to provide required in-plane stiffness, bending stiffness, shear stiffness, coefficient of thermal expansion, and so on. Different materials can be used in different layers, producing a hybrid laminate. In general, the individual layers are orthotropic or transversely isotropic, making the laminate anisotropic.

Multiscale analysis of a composite laminate can be performed using micromechanical and macromechanical modeling approaches. A micromechanical analysis considers an individual constituents in a material subvolume. The aim is to compute the homogenized material properties of a single layer. In contrast, a macromechanical analysis considers an entire laminate that consists of many layers. The aim is to compute the macroscopic response of a laminate under various loading conditions.

In COMSOL Multiphysics, composite laminates are analyzed either using Layerwise 3D Elasticity theory through the Layered Shell interface or using First Order Shear Deformation theory (ESL-FSDT) theory through one of the **Linear Elastic Material, Layered, Hyperelastic Material, Layered**, or **Piezoelectric Material, Layered** material models in the Shell interface. Very thin laminates, of essentially zero bending stiffness, are analyzed using an equivalent single layer theory using the **Linear Elastic Material, Layered** material model in the Membrane interface.

In composite laminates, different types of failures may appear. Thus, it is important to perform failure analyses of composite laminates. Both laminate theories allow computation of failure indices and safety factors based on various general, as well as fiber composite specific, failure criteria. Buckling of a composite laminate is a common phenomenon and important to consider in design. In addition, a composite laminate

consists of many layers glued/laminated together. Under different loading conditions, especially impact loading, the bond between two layers may break in a specific region. The modeling of delamination initiation and damage propagation is important to accurately predict the response of a damaged composite laminate.

Conventionally, a composite laminate is designed based on structural requirements. However, for an application where electrical or thermal effects are significant, it may also be necessary to design the laminate based on combined structural, thermal, and electrical requirements. A tool is required that can solve for other physical phenomena, especially electrical and thermal, in addition to structural mechanics. This multiphysics modeling is possible using the Composite Materials Module together with the Heat Transfer Module and the AC/DC Module.

Composite laminates are defined on boundaries, with layered materials attached to them. They are in general in-plane anisotropic, and heterogeneous in the through-thickness direction. It is important to be able to evaluate results in each layer, as well as in the through-thickness direction, and not only on the reference surface. There are various predefined tools which aid in the visualization of results for a composite laminate.

---

In the *COMSOL Multiphysics Reference Manual*:



- [Studies and Solvers](#)
- [The Physics Interfaces](#)
- For a list of physics interfaces included with a COMSOL Multiphysics license, see [Physics Interface Guide](#).

---

### *Where Do I Access the Documentation and Application Libraries?*

A number of online resources have more information about COMSOL, including licensing and technical information. The electronic documentation, topic-based (or

context-based) help, and the Application Libraries are all accessed through the COMSOL Desktop.



If you are reading the documentation as a PDF file on your computer, the [blue links](#) do not work to open an application or content referenced in a different guide. However, if you are using the Help system in COMSOL Multiphysics, these links work to open other modules, application examples, and documentation sets.

## THE DOCUMENTATION AND ONLINE HELP



The *COMSOL Multiphysics Reference Manual* describes the core physics interfaces and functionality included with the COMSOL Multiphysics license. This book also has instructions on how to use COMSOL Multiphysics and how to access the electronic Documentation and Help content.

### *Opening Topic-Based Help*

The Help window is useful as it is connected to the features in the COMSOL Desktop. To learn more about a node in the Model Builder, or a window on the Desktop, click to highlight a node or window, then press F1 to open the Help window, which then displays information about that feature (or click a node in the Model Builder followed by the **Help** button (  ). This is called *topic-based* (or *context*) *help*.

Win

To open the **Help** window:

- In the **Model Builder**, **Application Builder**, or **Physics Builder**, click a node or window and then press F1.
- On any toolbar (for example, **Home**, **Definitions**, or **Geometry**), hover the mouse over a button (for example, **Add Physics** or **Build All**) and then press F1.
- From the **File** menu, click **Help** (  ).
- In the upper-right corner of the COMSOL Desktop, click the **Help** (  ) button.

## Opening the Documentation Window

Win

To open the **Documentation** window:

- Press Ctrl+F1.
- From the **File** menu, select **Help > Documentation** (  ).

## THE APPLICATION LIBRARIES WINDOW

Each model or application includes documentation with the theoretical background and step-by-step instructions to create a model or application. The models and applications are available in COMSOL Multiphysics as MPH files that you can open for further investigation. You can use the step-by-step instructions and the actual models as templates for your own modeling. In most models, SI units are used to describe the relevant properties, parameters, and dimensions, but other unit systems are available.

Once the Application Libraries window is opened, you can search by name or browse under a module folder name. Click to view a summary of the model or application and its properties, including options to open it or its associated PDF document.



[The Application Libraries Window](#) in the *COMSOL Multiphysics Reference Manual*.

## Opening the Application Libraries Window

To open the **Application Libraries** window (  ):

Win

From the **File** menu, select **Application Libraries**.

To include the latest versions of model examples, from the **File > Help** menu select (  ) **Update COMSOL Application Libraries**.

Mac

From the **File** or **Windows** menu, select **Application Libraries**.

Linux

To include the latest versions of model examples, from the **Help** menu select (  ) **Update COMSOL Application Libraries**.

## CONTACTING COMSOL BY EMAIL

For general product information, contact COMSOL at [info@comsol.com](mailto:info@comsol.com).

## COMSOL ACCESS AND TECHNICAL SUPPORT

To receive technical support from COMSOL for the COMSOL products, please contact your local COMSOL representative or send your questions to [support@comsol.com](mailto:support@comsol.com). An automatic notification and a case number will be sent to you by email. You can also access technical support, software updates, license information, and other resources by registering for a COMSOL Access account.

## COMSOL ONLINE RESOURCES

COMSOL website	<a href="http://www.comsol.com">www.comsol.com</a>
Contact COMSOL	<a href="http://www.comsol.com/contact">www.comsol.com/contact</a>
COMSOL Access	<a href="http://www.comsol.com/access">www.comsol.com/access</a>
Support Center	<a href="http://www.comsol.com/support">www.comsol.com/support</a>
Product Download	<a href="http://www.comsol.com/product-download">www.comsol.com/product-download</a>
Product Updates	<a href="http://www.comsol.com/product-update">www.comsol.com/product-update</a>
COMSOL Blog	<a href="http://www.comsol.com/blogs">www.comsol.com/blogs</a>
Discussion Forum	<a href="http://www.comsol.com/forum">www.comsol.com/forum</a>
Events	<a href="http://www.comsol.com/events">www.comsol.com/events</a>
COMSOL Application Gallery	<a href="http://www.comsol.com/models">www.comsol.com/models</a>
COMSOL Video Gallery	<a href="http://www.comsol.com/videos">www.comsol.com/videos</a>
Learning Center	<a href="http://www.comsol.com/support/learning-center">www.comsol.com/support/learning-center</a>
Support Knowledge Base	<a href="http://www.comsol.com/support/knowledgebase">www.comsol.com/support/knowledgebase</a>



# Composite Materials Modeling

This chapter introduces you to the modeling of composite materials.

In this chapter:

- [About Composite Materials](#)
- [About Laminated Composite Shells](#)
- [Micromechanics Modeling](#)
- [Macromechanics Modeling](#)
- [Laminated Shell Theories](#)
- [Layered Membrane](#)
- [Layered Materials](#)
- [Layer and Interface Selections](#)
- [Failure Modeling](#)
- [Structural Couplings](#)
- [Multiphysics Modeling](#)
- [Results Evaluation](#)

# About Composite Materials

A composite material is a heterogeneous material formed from two or more constituents, assembled to achieve enhanced structural performance. Owing to the improved strength and reduced weight, when compared to conventional materials, the range of applications of composite materials spans across diverse fields. This necessitates a thorough understanding of the behavior of these materials.

Research is underway to find ways to embed functionality like sensing, actuation, computation, and communication into composite materials. This is known as smart composite materials.

Some examples of engineered composite materials for various applications include:

- Fiber reinforced polymers
- Reinforced concrete beams
- Composite wood or plywood
- Ceramic matrix composites
- Sandwich structures
- Metal matrix composites

Among different types of engineered composite materials, the use of fiber reinforced polymer (FRP) is growing rapidly. Applications include aircraft components, spacecraft components, wind turbine blades, automobiles, buildings, boat hulls, bicycles, and safety equipment.

This section includes:

- [Classification of Composites](#)
- [Fiber-Reinforced Polymer \(FRP\) Composites](#)
- [Benefits of Composites](#)
- [Challenges of Composites](#)

## *Classification of Composites*

---

There are several ways to classify composite materials, and one way is to categorize them based on their constituents: the type of matrix material, and the type of reinforcement.

Based on the type of matrix material, composite materials can be categorized as:

- Polymer matrix composites (PMC)
- Metal matrix composites (MMC)
- Ceramic matrix composites (CMC)
- Cement matrix composites (CeMC)

Based on the reinforcement shape, composite materials can also be categorized as:

- Continuous fibers
- Random short fibers
- Flakes
- Whiskers
- Particulate

A commonly used type of fiber-reinforced polymer (FRP) is polymer matrix composites (PMC), in which continuous fibers are used as reinforcement.

### *Fiber-Reinforced Polymer (FRP) Composites*

---

A fiber-reinforced polymer (FRP) typically consists of a fibrous part, which acts as the main load carrying element, and a surrounding matrix/resin to support the fiber, and transfer the load. The fibers are arranged in a specified orientation in each layer (equivalently lamina or ply) of the material. A number of layers are stacked to form a laminated composite material which can be used in structural components.

The use of fiber composites in the manufacturing industry is increasing, as fiber composites are lighter and more corrosion resistant compared to traditional metallic engineering materials. Moreover, properties like strength, stiffness, and toughness can often be tailored to a specific application.

The fibers used for industrial applications are in general made of carbon, glass, aramid, or basalt. Based on the type of fiber material, the two most popular FRPs in industry are:

- Carbon fiber reinforced polymers (CFRP)
- Glass fiber reinforced polymers (GFRP), also known as fiberglass

### *Benefits of Composites*

---

Composite materials offer many benefits over conventional metallic materials. Some possible benefits are:

- High strength to weight ratio
- High resistance to fatigue and corrosion degradation
- Improved friction and wear properties
- Low thermal conductivity and low coefficient of thermal expansion
- Possibility to tailor material properties to meet specific design requirements

### *Challenges of Composites*

---

Considering that composite materials are manufactured materials, there are challenges involved when selecting a composite material for an application:

- High cost of raw materials and fabrication
- Difficulty in reuse and disposal
- Difficulty in joining different components
- Different types of failure modes
- Anisotropic materials — difficult to analyze

# About Laminated Composite Shells

A laminated composite shell, also known as composite laminate, is an assembly of layers (laminae, plies) of composite materials. It is assembled to meet specific design requirements on, for example, in-plane stiffness, bending stiffness, shear stiffness, and coefficient of thermal expansion. Different materials can be used in different layers, resulting in a hybrid laminate. In general, the individual layers are orthotropic or transversely isotropic, making the composite laminate anisotropic.

This section includes:

- [Reinforcement Arrangement](#)
- [Stacking Sequence](#)
- [Types of Laminates](#)
- [Analysis on Different Scales](#)

## *Reinforcement Arrangement*

---

Depending on the manner in which fibers are arranged in a matrix material, composite plies can be categorized as:

- Unidirectional composite
- Bidirectional composite
- Woven fabric composite
- Particulate composite

Woven fabric composites are produced by the interlacing of warp ( $0^\circ$ ) fibers and weft ( $90^\circ$ ) fibers, in different weave styles. A woven fabric can be in biaxial, triaxial, or multiaxial configurations, and can have different types of weaving, namely planar weaving or 3D weaving.

Particulate composites are made by introducing particles, flakes, or whiskers into an otherwise isotropic matrix.

## Stacking Sequence

---

A composite laminate is defined as the stacking of two or more composite plies with the same or different fiber orientations. The plies (layers) can be made of the same or different materials, with individual thicknesses.

The stacking sequence, shown in [Figure 2-1](#), is defined by the fiber orientation of each ply with respect to the first axis of the laminate coordinate system. The stacking sequence is interpreted from bottom to top, and the orientation angles are in general specified in degrees.

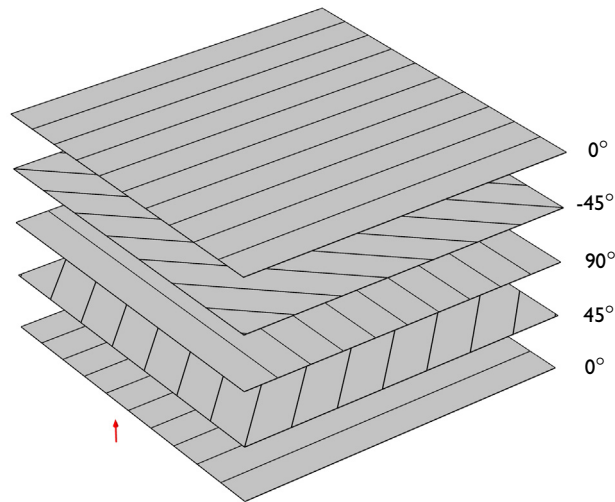

*Figure 2-1: Example of a stacking sequence [0/45/90/-45/0] used in a composite laminate.*

The stacking sequence is expressed in a concise form that is particularly suitable for laminates with a large number of plies (layers), using the fact that most laminates are either symmetric or contain many plies of the same orientation.

Some examples of stacking sequences are given in the table below:

TABLE 2-1: EXAMPLE STACKING SEQUENCES.

STACKING SEQUENCE	ORDER OF THE PLYS	PLIES
[45/-30/0]	45°, -30°, 0°	3
[45/-30/0] <sub>s</sub>	45°, -30°, 0°, 0°, -30°, 45° (s = symmetric)	6
[45/-30/0] <sub>3</sub>	Three repeated sets of 45°, -30°, 0°	9
[(45) <sub>2</sub> /-30/(0) <sub>3</sub> ] <sub>s</sub>	45°, 45°, -30°, 0°, 0°, 0°, 0°, 0°, 0°, -30°, 45°, 45°	12
[45/-30/0] <sub>as</sub>	45°, -30°, 0°, 0°, 30°, -45° (as = antisymmetric)	6

### *Types of Laminates*

Based on the stacking sequence, composite laminates can be categorized as:

#### *Angle-ply Laminate*

A laminate is called an *angle-ply laminate* if it has layers of the same thickness and material, and are oriented at  $\theta$  and  $-\theta$ .

#### *Cross-ply Laminate*

A laminate is called a *cross-ply laminate* if all the layers have the orientation  $0^\circ$  and  $90^\circ$ .

#### *Balanced Laminate*

A laminate is called a *balanced laminate* when it has pairs of layers of the same thickness and material, and the angles of the layers have opposite signs. Balanced laminates can also have layers at  $0^\circ$  and  $90^\circ$ .

#### *Symmetric Laminate*

A laminate is called *symmetric* when the material, angle, and thickness of the layers are the same above and below the midplane.

#### *Antisymmetric Laminate*

A laminate is called *antisymmetric* when the material and thickness of the layers are the same above and below the midplane, but the orientation of the layers have opposite signs above and below the midplane.

### *Analysis on Different Scales*

The analysis of a composite laminate is comparatively difficult as it spans different length scales. At the micro level, individual fibers or particles embedded in a matrix

material are considered, and at the macro level, the homogenized behavior of the composite laminate is considered.

#### **MICROMECHANICS ANALYSIS**

This analysis considers the modeling of individual layers using either repeating unit cell (RUC) or representative volume element (RVE) of fibers or particles in a matrix. The micromechanics analysis is used to compute the homogenized material properties of a single layer.

#### **MACROMECHANICS ANALYSIS**

This analysis considers the modeling of a laminate having many layers. The homogenized material properties of a single layer, computed in the micromechanics analysis, is the input to this analysis. The aim is to compute the global response of a laminate under various loading conditions.

#### **MULTISCALE ANALYSIS**

In a multiscale analysis, you typically compute the global response using a macromechanics analysis, and then use the global stress and strain field in a set of points to as boundary conditions for a microscale model, in order to determine local stresses and strains.

# Micromechanics Modeling

To analyze components made from laminated composites, it is necessary to quantify the material properties of an individual lamina (layer, ply). The task of computing homogenized material properties using either repeating unit cell (RUC) or representative volume element (RVE) is known as micromechanics analysis. The homogenized material properties can be computed when the material properties and distribution for the fibers and matrix are known.

## *Constituents of a Lamina*

---

A lamina, in general, consists of fibers in a matrix. The homogenized properties of a lamina depend on the material properties of the fibers and the matrix, and on their distribution. The fibers are in general orthotropic, whereas the filler material is isotropic.

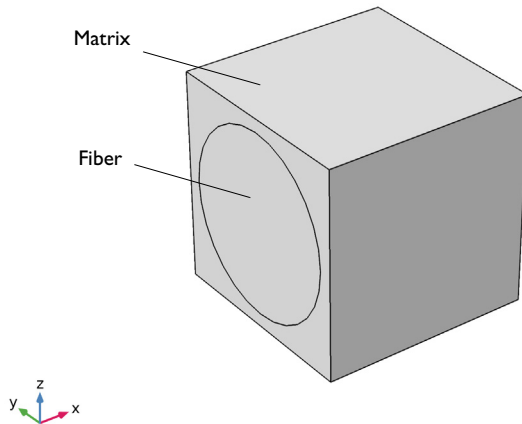

*Figure 2-2: Example of a unit cell of a lamina having fiber and matrix materials.*

A repeating unit cell (RUC) or representative volume element (RVE), is the smallest volume element which can be repeated to describe the full lamina. An example of a unit cell is shown in [Figure 2-2](#), where it is assumed that the fibers are located on a regular square lattice. With this RUC, the volume fraction of fibers is sufficient to describe the

fiber content in the lamina. The length of the RUC in the fiber direction is immaterial, while the size in the two transverse directions is given by the spacing between fibers.

### *Parts for Micromechanical Analysis*

---

In the **Geometry** toolbar navigate to **Parts > Part Libraries**. In the Part Libraries, under **COMSOL Multiphysics > Unit Cells and RVEs**, several parameterized geometries for common micromechanical structures are available. They form a good basis for computing homogenized material properties.

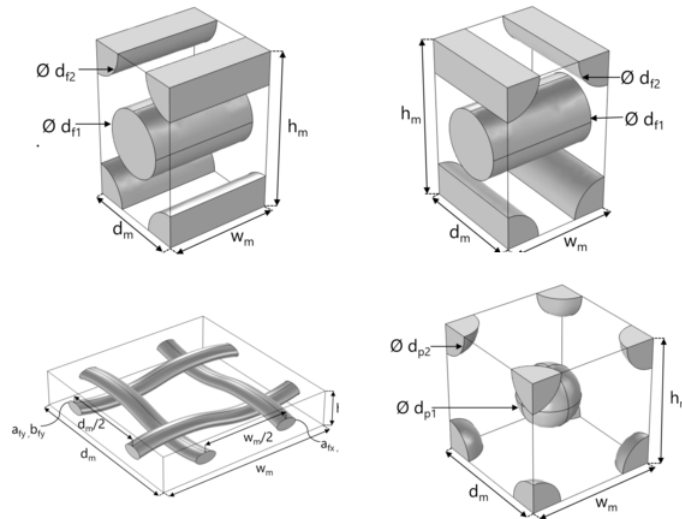

*Figure 2-3: Some examples of unit cell geometries in the Part Libraries.*

### *Homogenization and Cell Periodicity*

---

In order to perform a micromechanics analysis of a composite lamina and compute its homogenized orthotropic material properties, the **Cell Periodicity** node in the Solid Mechanics interface is used.

In order to extract the homogenized material properties, the **Cell Periodicity** node performs the following sequence of operations:

- Applies periodic boundary condition to three pairs of faces of the RUC or RVE.
- Creates a stationary study with six different unit load cases.

- Solves load cases and obtains the components of homogenized elasticity matrix of a lamina from the computed stress-strain relations.
- Creates a new homogeneous material node under **Global Definitions**- > **Materials** and assigns the computed homogenized elasticity matrix to it.

This new homogeneous material can be used as an input to the macromechanics analysis.



In the *Structural Mechanics Module User's Guide*:

- [Effective Properties of Periodic Structures](#)
  - [Cell Periodicity](#)
  - [Cell Periodicity](#)
-

# Macromechanics Modeling

Modeling a composite laminate and computing its response under loading is known as macromechanics analysis. The homogenized material properties of a lamina computed using a micromechanics analysis can be used as input to the macromechanics analysis.

In order to model a composite laminate, the following properties need to be specified:

- Number of layers
- Homogenized material properties of each layer
- Orientation of the principal material directions
- Thickness of each layer
- Stacking sequence

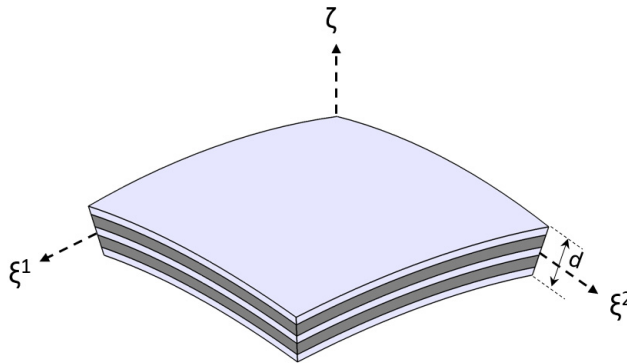

*Figure 2-4: A 3D representation of a composite laminate showing the total laminate thickness and the laminate coordinate system.*

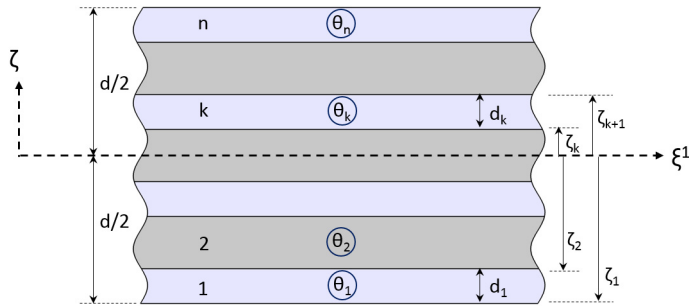

Figure 2-5: Through-thickness (2D) representation of a composite laminate with  $n$  layers. The thickness and fiber orientation of each layer are indicated. The position of the reference surface with respect to the laminate is also shown.

In order to attach the layer definition to geometric surfaces, the following properties need to be defined:

- Laminate coordinate system: These are the global directions for a composite laminate about which the stacking sequence is interpreted as shown in Figure 2-4.
- Reference surface position: This is the position of the reference surface or geometric surface with respect to the midplane of the laminate as shown in Figure 2-5.

Once these definitions are specified, a regular finite element modeling approach can be used. It involves setting up the physics (loads, boundary conditions), creating a finite element mesh, performing various types of analysis, including static, dynamic, failure, buckling, and multiphysics analysis.

# Laminated Shell Theories

The analysis of laminated composite shells is commonly based on one of three different theories:

- 1 Equivalent single layer (ESL) theory
  - a Classical laminated plate theory (CLPT)
  - b First order shear deformation laminated plate theory (FSDT)
  - c Higher order shear deformation laminated plate theory
- 2 Three dimensional elasticity theory
  - a Traditional 3D elasticity theory
  - b Layerwise 3D elasticity theory
- 3 Multiple model methods

In COMSOL Multiphysics, composite laminates are analyzed either using layerwise 3D elasticity theory through the Layered Shell interface or using first order shear deformation theory (ESL-FSDT) theory through the **Linear Elastic Material, Layered**, **Hyperelastic Material, Layered**, or **Piezoelectric Material, Layered** material models in the Shell interface.

This section includes:

- [Equivalent Single Layer \(ESL\) Theory](#)
- [Layerwise \(LW\) Theory](#)
- [Selection of an Appropriate Laminate Theory](#)

## *Equivalent Single Layer (ESL) Theory*

---

Composite laminates are formed by stacking layers of different materials and/or different fiber orientations. In general, their planar dimensions are two orders of magnitude larger than their thickness. Often laminated structures are used in applications requiring high membrane and bending strengths. Therefore, in many cases, composite laminates can be modeled using a shell element based on an equivalent single layer theory.

This is a classical way of modeling composite laminates. This theory treats a heterogeneous laminated composite as a statically equivalent single layer. It reduces a

3D continuum problem to an equivalent 2D problem, thus reducing the size and computational time of the problem.

In addition to simplicity and low computational cost, this theory provides sufficiently accurate description of the global response for a thin to moderately thick laminates such as gross deflections, critical buckling loads, and eigenfrequencies with corresponding mode shapes.

### **CLASSIFICATION**

The ESL theories can be classified into various groups based on the description of the transverse shear stresses.

#### *Classical Laminate Plate Theory (CLPT)*

The classical laminate plate theory is an extension of Kirchhoff or classical plate theory used for single layer thin shells. In this theory, transverse shear stresses are neglected and the deformation is entirely due to the bending and in-plane stretching.

#### *First Order Shear Deformation Theory (FSDT)*

The first order shear deformation theory is similar to the Mindlin–Reissner shell theory used for single layer thick shells. This theory extends the kinematics of CLPT by including the gross transverse shear deformation. The transverse shear strain is assumed to be constant with respect to the thickness coordinate. As the transverse shear strain has a constant value, this theory requires a shear correction factor.

#### *Higher Order Shear Deformation Theory*

This theory is the extension of FSDT, and here the displacement field is approximated in such a way that the transverse shear strain varies quadratically with respect to the thickness coordinate. It makes the transverse shear stresses zero at the top and bottom surfaces of the laminate and thus eliminates the need of a shear correction factor.

### **FIRST ORDER SHEAR DEFORMATION THEORY (FSDT)**

In COMSOL Multiphysics, the first order shear deformation (ESL-FSDT) theory is one of the options for analyzing composite laminates. This theory is implemented in the **Linear Elastic Material**, **Layered, Hyperelastic Material**, **Layered**, and **Piezoelectric Material**, **Layered** material models in the Shell interface. It has an MITC (*mixed interpolation of tensorial components*) formulation. As this theory accounts for the transverse shear deformation, it can be used for thick shells.

### **KEY FEATURES**

- Degrees of freedom (3 displacements, 3 rotations) are defined only at the midplane or reference plane of the composite laminate.

- Suitable for modeling thin to moderately thick laminates.
- Suitable for finding the global response of the laminate such as gross deflections, eigenfrequencies, and critical buckling load.
- Computationally inexpensive, and thus suitable for analysis of laminates having large numbers of layers.
- Requires a shear correction factor for thicker laminates, where transverse shear stresses are not negligible



In the *Structural Mechanics Module User's Guide: Theory for FSDT Laminated Shell*

---

### *Layerwise (LW) Theory*

---

A layerwise (LW) theory for modeling composite laminates is very similar to a traditional 3D elasticity theory, where the degrees of freedom are the displacements defined in the product geometry created by the reference surface, and an extra dimension in the thickness direction.

There are two approaches depending on the way degrees of freedom are defined:

- Partial displacement field approach
- Full displacement field approach

In the partial displacement field approach, the laminate thickness remains constant, whereas the full displacement field approach allows a change in thickness of the laminate. In COMSOL Multiphysics, a full displacement field based layerwise theory is implemented in the Layered Shell interface.

The layerwise theory is more accurate than the equivalent single layer theory, but it comes at the cost of more degrees of freedom. It is significantly more expensive in terms of computer resources.

From accuracy point of view, the layerwise theory is as accurate as traditional 3D elasticity theory, but it has several benefits:

- No need to build a 3D geometry with many thin layers.
- Easy to handle layerwise and interfacial data.

- In-plane finite element meshing is independent of the out-of-plane (thickness direction) meshing.
- A separate, either lower or higher, shape function order can be chosen in the thickness direction in order to avoid shear locking or to gain accuracy advantages.

#### **KEY FEATURES**

- Degrees of freedom (3 displacements) are defined in the product geometry created by the reference surface, with an extra dimension in the thickness direction.
- Predicts correct through-thickness or transverse shear stress variation, thus making it suitable for modeling thick shells.
- Predicts correct interlaminar stresses, and has degrees of freedom in the thickness direction making it suitable for delamination and detailed damage analysis.
- Supports nonlinear material models for advanced composite modeling.
- Supports different material models in different layers of a laminate. It is for example possible to combine linear elastic and hyperelastic materials in a single laminate.

#### *Selection of an Appropriate Laminate Theory*

---

In the above two sections, the key features of both equivalent single layer and layerwise theories have been outlined. Based on that, an appropriate laminate theory can be chosen for a particular problem. Without going into more details, the laminate aspect ratio (the ratio between in-plane size and thickness) gives an important hint about the theory that would be more suitable for a particular laminate.

In [Figure 2-6](#), it can be seen that ESL theory is more suitable for moderately thick to very thin laminates, whereas layerwise theory is more suitable for moderately thin to very thick laminates. The selection of ESL theory for very thick laminates may give rise

to incorrect transverse shear stresses whereas the selection of layerwise theory for very thin laminates may give rise to shear locking.

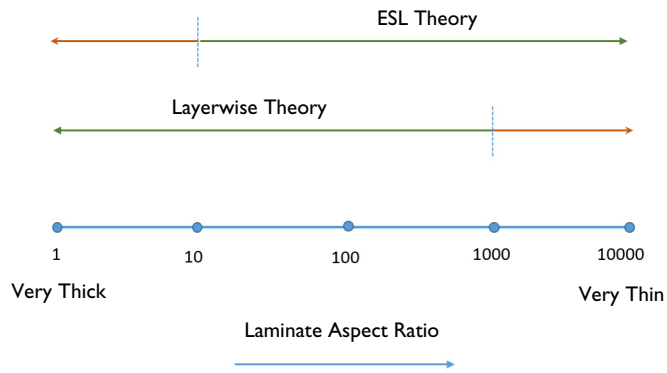

*Figure 2-6: Selection of an appropriate laminate theory based on the laminate aspect ratio.*

# Layered Membrane

In order to model very thin laminates with low bending stiffness, the Equivalent Single Layer theory can be extended to the membrane elements. One of the applications of the layered membrane is in the modeling of acoustic devices.

In COMSOL Multiphysics, very thin laminates are analyzed using the equivalent single layer theory through the [Linear Elastic Material, Layered](#) in the Membrane interface. This material model is a membrane version, with zero bending and shear energies, of the **Linear Elastic Material, Layered** material model in the Shell interface, which is based on the First Order Shear Deformation theory.

# Thin Layers

In the Solid Mechanics interface, there is a possibility to model thin layers on boundaries between solid domains, using the [Thin Layer](#) feature. It can also be used to model a cladding on an exterior boundary. With the Composite Materials Module, such thin layers can internally be multilayered. The same type of [Layered Materials](#) that is used for shells and membranes is applicable also in this case.

# Layered Materials

The technique for defining material data and other properties for a layered shell is somewhat different from what is common in most other physics interfaces. In general, several different materials are used on the same boundary, so it would not be possible to use the assignment in a normal **Material** node in the component.

Rather, you defined the whole laminate, including materials, layer thickness, orientations, and so on, as one unit. The workflow is described in this section.

This section includes:

- [Defining a Layered Material](#)
- [Connecting a Layered Material to the Physical Geometry](#)
- [Defining a Laminate Coordinate System](#)
- [Defining a Layer Local System](#)
- [Defining a Layered Material Stack](#)
- [Defining Variable Thickness Layers](#)
- [Ply-Based Modeling Approach](#)
- [Saving and Loading Layered Material](#)
- [Sweep over Layered Materials](#)
- [Visualizing 3D Geometry and Fiber Draping](#)

## *Defining a Layered Material*

---

Start by adding a **Layered Material** at the **Materials** node under **Global Definitions**. Then, take the following steps to define the laminate:

- Add the required number of layers in the **Layer Definition** section of a **Layered Material** node.
- Define the referenced materials under the **Materials** node. You can either add a **Blank Material** and fill in the required material properties or choose a material from the **Material Library**.
- Select the appropriate material in each layer.
- Define the rotation angle (in degrees) for each layer. This is the orientation of the fiber direction with respect to the principal laminate coordinate system.

- Define the thickness of each layer.
- By default, two mesh elements in each layer are used which means there are two sublayers in each material layer. Optionally, you may want to either increase or decrease the number of mesh elements in an individual layer in order to improve the accuracy or reduce the computation time.



Note that required material properties for the material in a certain layer depends on the **Solid Model** chosen in the **Linear Elastic Material** node in Layered Shell or **Linear Elastic Material, Layered** node in Shell interface.

- For the **Isotropic** model (with Young's modulus and Poisson's ratio option), scalar values of Young's modulus and Poisson's ratio are required.
- For the **Orthotropic** and **Transversely Isotropic** model, Young's modulus, shear modulus, and Poisson's ratio along the principal material directions is required.
- For the **Anisotropic** model, the full homogenized elasticity matrix of along the principal material directions is required.



## INTERFACE MATERIALS

By default, no material is selected on the interface between two layers in the through-thickness direction. The material properties at the interface are taken as an average of the two adjacent layer properties.

All the layers are assumed in a continuity state. Optionally, in order to model a very thin layer of material, for example a glue layer between the two material layers, a material can be added in **Interface Properties** section. If an interface material is defined, you can create a discontinuity between two layers and use the interface material properties. To do this, add a **Delamination** or **Thin Elastic Layer, Interface** node in the Layered Shell interface. All interfaces selected in that node should have a material assignment, but there is no need to assign a material to interfaces which are not affected by such special features.

## PREVIEW PLOTS

As the physical geometry is only the boundaries, it becomes important to visualize the layup, including stacking sequence and thickness values for each layer.

You can do that by creating **Layer Cross Section Preview** () and **Layer Stack Preview** () plots. An example of a layer cross section plot showing a 2D cross section of a

laminates having is shown in [Figure 2-7](#). The thickness of each layer is visible. An example of a layer stack preview plot showing the stacking sequence is shown in [Figure 2-8](#).

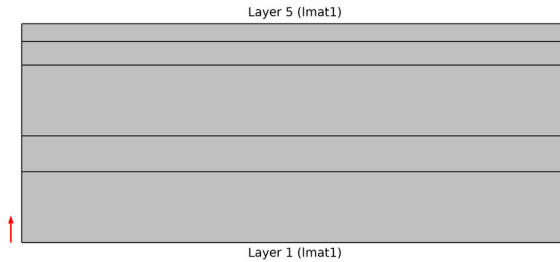

*Figure 2-7: Example of a layer cross section preview plot showing a composite laminate having 5 layers with different thickness values.*

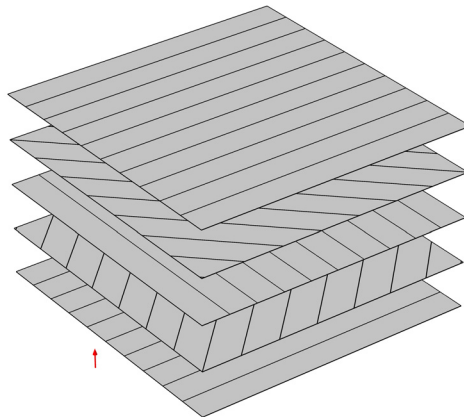

*Figure 2-8: Example of a layer stack preview plot showing a composite laminate having 5 layers with stacking sequence [0/45/90/-45/0].*

Note that in the layer stack preview plot, the distance between any two layers is always the same and it does not reflect the actual thickness of the layers.

Since the preview plots are used for a variety of composite laminates having different combination of number of layers, thickness values, and stacking sequence, it is possible to customize the plot settings in terms of changing the thickness to width ratio or the distance between the orientation lines. It is also possible to switch off the orientation lines and labels.

You can also create the two preview plots under **Results** section using **Create Layer Cross Section Plot** and **Create Layer Stack Plot** buttons respectively. This helps in storing the preview plots in the model and also allows them to be available in an application, built on top of the model.



In the *COMSOL Multiphysics Reference Manual*:

- [Layered Material](#)
- 

### *Connecting a Layered Material to the Physical Geometry*

---

After creating the layered material definition, the next step is to attach the layer definition to the physical geometrical surfaces. The most fundamental way of doing that is through a **Layered Material Link** node, which you add under the **Materials** node within a component.

In that node, you select the boundaries where you want to attach the layer definition. The position of the geometric boundaries with respect to laminate definition is also defined. You can attach the boundary to the laminate midplane, downside, upside, or at a user-defined location as shown in [Figure 2-9](#).

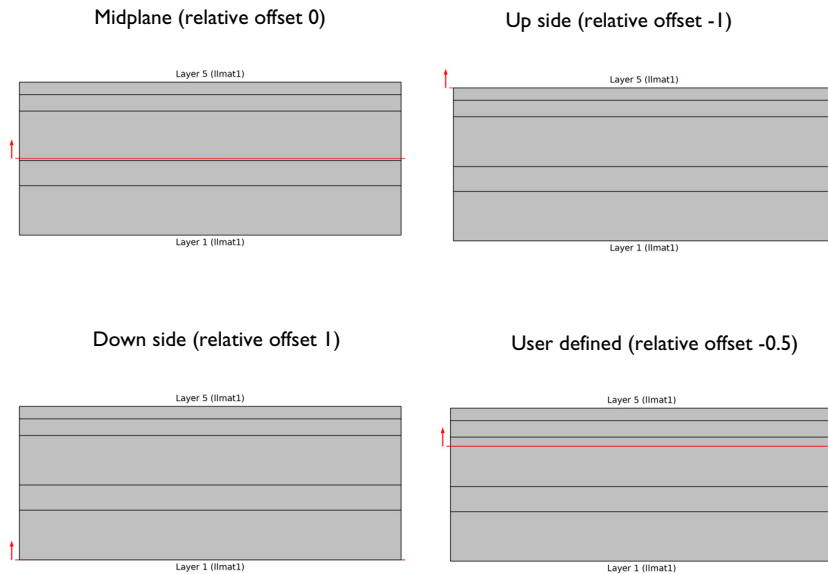

*Figure 2-9: Position of geometric boundaries with respect to the composite laminate.*

It is also possible to use some of the transform options while attaching the layer definition to the boundaries. By default, the layer definition is used as it is however it is possible to use the following transform options:

- Symmetric
- Antisymmetric
- Repeated

### *Defining a Laminate Coordinate System*

---

The next step is to define a coordinate system for the composite laminate in which the stacking sequence is interpreted. You can either customize the default **Boundary System** or add new boundary systems under the **Definitions** node within a component. Select the coordinate system in the **Layered Material Link** node.

To create a suitable laminate coordinate system using the **Boundary System** node

- Define an appropriate direction from which the first tangent direction of the coordinate system is obtained
- Reverse the normal direction if needed

Some examples of laminate coordinate systems in a cylindrical composite laminate, using different **Boundary System** settings are given below.

#### Example 1

The first axis of the laminate coordinate system is aligned with the global  $x$  direction. This can be created by setting the **Create first tangent direction from** option to **Global Cartesian (spatial)** and the **Axis** to  $x$ .

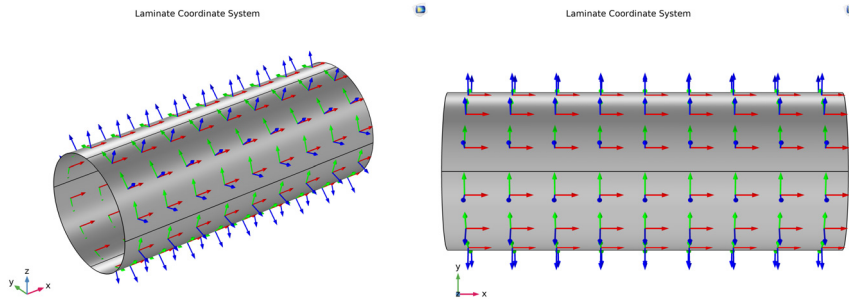

*Figure 2-10: Example of a laminate coordinate system when the first axis is aligned with the global  $x$  direction.*

#### Example 2

The first axis of the laminate coordinate system is at  $45^\circ$  to the global  $x$  direction. This can be created by first defining a **Cylindrical System** having **Longitudinal axis** as  $x$ -axis

and then setting the **Create first tangent direction from** to **Cylindrical System** and **Axis** to **Manual** with  $\{0,-1,1\}$  as orientation.

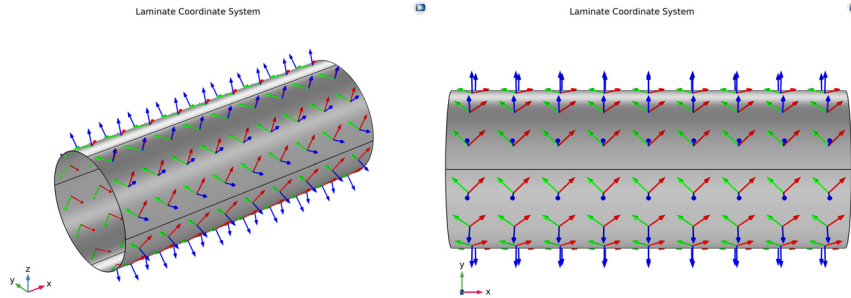

Figure 2-11: Example of a laminate coordinate system when the first axis is at  $45^\circ$  to the global  $x$  direction.

### Example 3

The first axis of the laminate coordinate system is aligned with the global  $x$  direction but with the normal direction pointing inward. This coordinate system can be created in a same way as in the first example. In addition to that, the **Reverse Normal** direction option is selected in the **Boundary System** node in order to flip the normal vector direction.

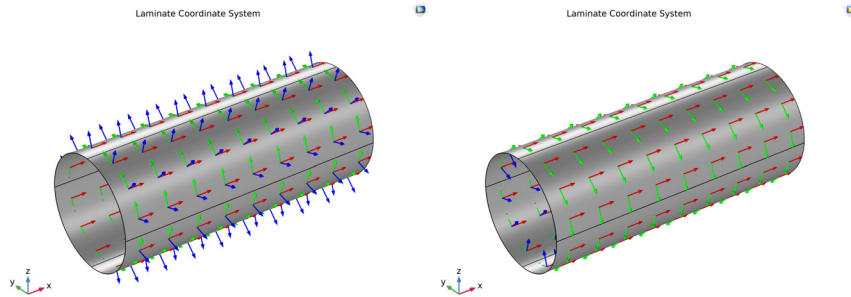

Figure 2-12: Example of a laminate coordinate system where the first axis is aligned with the global  $x$  direction and the normal vector is pointing outward and inward respectively.



Note that it is also possible to reverse the normal direction only on some selected boundaries by using the **Reverse Normal** subnode on the **Boundary System** node.



In the *COMSOL Multiphysics Reference Manual*:

- [Layered Material Link](#)
  - [Boundary System](#)
- 

### *Defining a Layer Local System*

---

Each layer in the composite laminate has different material orientations defined by the rotation angle and the laminate coordinate system. The rotation angle of each layer is defined in the **Single Layer Material** or **Layered Material** node. The **Layer Local System** is then created by rotating the laminate coordinate system in the reference plane by this rotation angle.

Some examples of layer local coordinate systems in a cylindrical composite laminate having different stacking sequences, are given below.

Some examples of layer local coordinate systems in a cylindrical composite laminate, using different stacking sequences, are given below.

#### *Example 1*

The stacking sequence of a composite laminate is [0/30/60/90]. The first axis of the laminate coordinate system is aligned with the global  $x$  direction. This can be created by setting the **Create first tangent direction from** option to **Global Cartesian (spatial)**, and by setting the **Axis** to **x**.

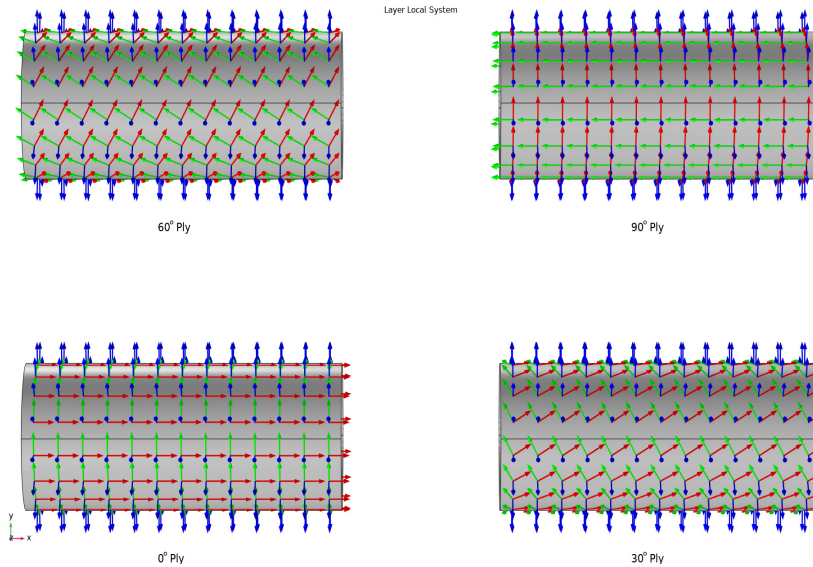

*Figure 2-13: Example of a layer local coordinate system in different plies. The first axis of the laminate coordinate system is the global  $x$  direction.*

#### Example 2

The stacking sequence of a composite laminate is  $[-15/15/-45/45]$ . The first axis of the laminate coordinate system is at  $45^\circ$  to the global  $x$  direction. This can be created by defining a **Cylindrical System** having **Longitudinal axis** as  $x$ -axis. Then set the **Create first tangent direction from to Cylindrical System** and the **Axis** to **Manual** with  $\{0,-1,1\}$  as the orientation.

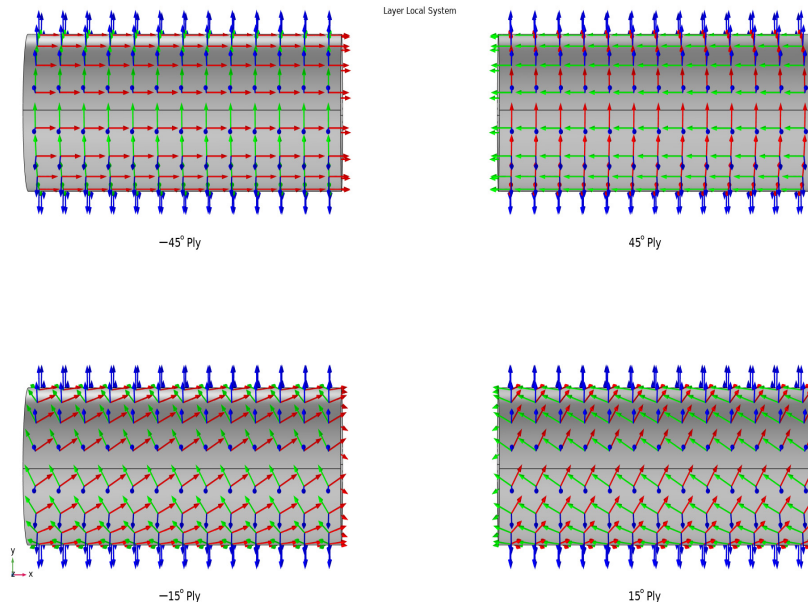
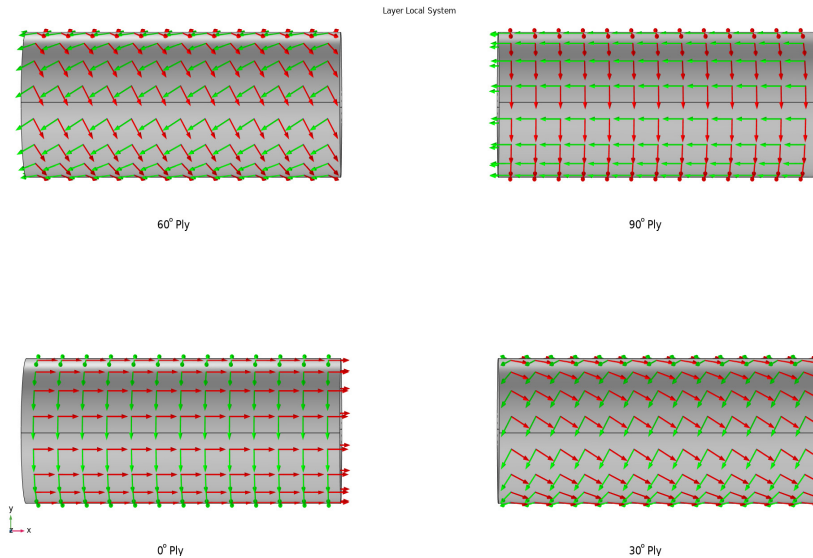

Figure 2-14: Example of a layer local coordinate system in different plies. The first axis of the laminate coordinate system is at  $45^\circ$  with respect to the global  $x$  direction.

### Example 3

The stacking sequence of a composite laminate is  $[0/30/60/90]$ . The first axis of laminate coordinate system is aligned with the global  $x$  direction but with the normal direction pointing inward. This coordinate system can be created in a same way as in the first example. In addition to that, the **Reverse Normal** direction option is selected in the **Boundary System** node in order to flip the normal vector.



*Figure 2-15: Example of a layer local coordinate system in different plies. The first axis of the laminate coordinate system is the global  $x$  direction, and the normal vector is pointing inward the cylinder.*

### *Defining a Layered Material Stack*

It is common that different layered materials are stacked on top of each other to build a composite laminate. An example is a laminate having the stacking sequence [A/B/C/B/A] where A, B, C are three different layered materials or sublaminates.

To simplify such modeling, use the **Layered Material Stack** node under the **Materials** node within a component. In a **Layered Material Stack**, you define the position and laminate coordinate system similar to what is done in a **Layered Material Link**. You can link multiple layered materials in the stacking order. An example of a layered material stack having three different layered materials is shown in [Figure 2-16](#).



Figure 2-16: Example of a layered material stack having three different (A,B,C) layered materials.



Note that it is also possible to add a **Layered Material** node directly under the **Layered Material Stack** node.



In the *COMSOL Multiphysics Reference Manual*: [Layered Material Stack](#)

### Defining Variable Thickness Layers

In some applications, one or more layers in a laminate can have a thickness variation as a function of geometry coordinate. These layers are typically core layers in sandwich laminates. This can be achieved by using the **Scale** option in the **Layered Material Link** or **Layered Material Stack** nodes.

In order to scale the entire laminate, the **Layered Material Link** node can be used however for individual layer scaling as shown in [Figure 2-17](#), the **Layered Material Stack** node more suited.

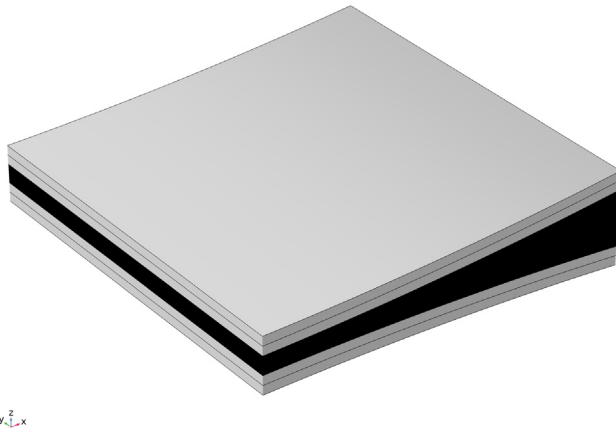

*Figure 2-17: Example of a layered material having a variable thickness layer in the middle shown in black.*

### *Ply-Based Modeling Approach*

---

There are two ways in which a complex composite laminate, with different layups in different parts of the structure, can be modeled:

- Using a zone-based modeling approach
- Using a ply-based modeling approach

The zone-based modeling approach is a traditional way of defining a layup in a composite laminate. First, all zones in the composite laminate that have different layups are identified. Second, the layup in each zone is defined using the **Layered Material Link** or **Layered Material Stack** node. This approach works fine as long as there is a limited number of ply drop-offs, so that the number of zones is limited.

In the case of a complex composite laminate with many ply drop-offs, and thus many zones, identifying and then defining the layup for each zone individually becomes a cumbersome process. In such a scenario, a ply-based modeling approach can be used. Here, only one layup is defined for all the zones using a **Layered Material Stack** node. Each ply then has its own selection, which is a subset of the selection of the **Layered Material Stack** node. This is different compared to the zone-based modeling approach, where each ply in the **Layered Material Stack** has the same selection.

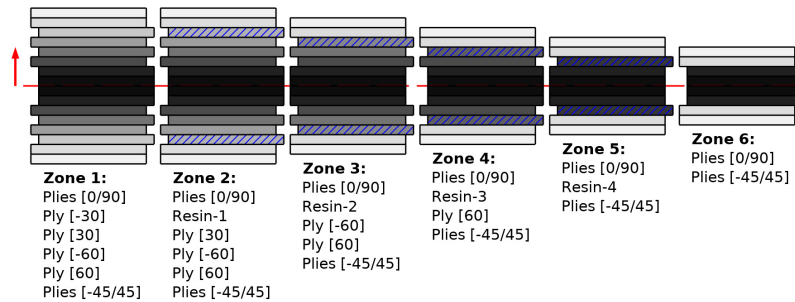

Figure 2-18: Zones created in the ply-based modeling approach. The layout in each zone can also be seen. A ply having sectioning represents the variable thickness ply.

Based on the overall layup information and the selection of each ply, different zones are automatically created and shown in the **Stack Zone Definition** section of the **Layered Material Stack** node. Each zone is treated as a different layered material and can be used accordingly in the physics and in postprocessing.

The typical steps involved in defining a complex layup using the ply-based modeling approach are:

- Use a **Layered Material Stack** node and make the selection where you want to define a layup.
- Add all the plies to the **Layered Material Stack** node in the specified stacking sequence using its subnodes — **Layered Material link**, **Layered Material**, or **Single Layer Material**.
- Define the boundary selection of each ply where it is physically present. This selection should be a subset of the **Layered Material Stack** node's selection.
- Based on the specified stacking sequence and the selection of each ply, the entire selection is divided into various zones which can be seen in the **Stack Zone Definition** section in the **Layered Material Stack** node.
- The table in the **Stack Zone Definition** section lists the **Name** of the zones, the **Stack members** in each zone, and the geometric **Selections** of each zone.
- Click on each row in the table to visualize the boundary selection of the zones in the **Graphics** window.

- Click the **Layer Cross Section Preview** plot button to visualize all the zones and their stacking sequence, as shown in [Figure 2-18](#).
- Click the **Layer Stack Preview** plot button to visualize the overall stacking sequence, and further, click on each row of the table to visualize the stacking sequence in each zone.



In the *COMSOL Multiphysics Reference Manual*: [Layered Material Stack](#)

---

### *Saving and Loading Layered Material*

---

After setting up a layered material definition together with the material properties of each layer, you may want to save it in order to reuse the data in a different model. This can be achieved in two different ways:

- Add the **Layered Material** to a **User-Defined Library** by right-clicking and choosing this option. This adds the layer definition as well as the material properties of each layer to the user-defined library.
- Save the model file with only the layered material setup.

Next time when you want to use the same layered material setup, then either you can add it from a **User-Defined Library** if it is available there, or you can browse to the model file in which layered material is stored by following these steps:

- Right click on **Materials** node under **Global Definitions** and choose **Browse Materials**.
- Choose **Import Material Library** and browse to the model file containing the layered material definition.
- Choose a layered material from the newly added material library and add it to the **Global Materials** in the model. Alternatively, you can add it to the **User-Defined Library**.

---

### *Sweep over Layered Materials*

---

In many cases, a primary goal while designing a composite laminate is to optimize the layered material definition which includes number of layers, arrangement of layers, material properties of each layer, thickness of each layer, and stacking sequence.

In order to do this, you can add multiple **Layered Material** nodes under a **Switch** node. You add the **Switch** node from **Materials** under **Global Definitions**. The **Switch** node can

be selected in the **Layered Material Link** node. However, all **Layered Material** nodes under a **Switch** node must have same number of layers, even though they can have different total thickness. To handle a case with several materials having different number of layers, you can split the layers in one or more **Layered Material** by adjusting layer thicknesses while keeping total thickness constant, so that total number of layers in all **Layered Materials** are the same.

With these settings, it is possible to add a **Material Sweep** node to any study in order to solve for all layered materials.

### *Sensitivity Analysis of Layered Materials*

---

It is not possible to directly compute the sensitivity of some result with respect to a layer thickness. This is an operation that you would, for example, need for optimization studies. There is, however, an indirect way to obtain such a sensitivity, and that is to use the **Scale** property available in a **Layered Material Link**. A scaling acts on all layers in a **Layered Material Link** node. In order to scale individual layers, you can use a **Layered Material Stack**, and add separate **Layered Material Link** subnodes pointing to these layers.

### *Visualizing 3D Geometry and Fiber Draping*

---

In complex structures, sometimes it becomes important to visualize the 3D solid geometry which corresponds to a composite laminate modeled using the surface geometry. It gives a clear picture of the number of layers as well as laminate thickness

in different regions of the structure. In order to visualize this, a result template is available in the Layered Shell and Shell interfaces as shown in [Figure 2-19](#).

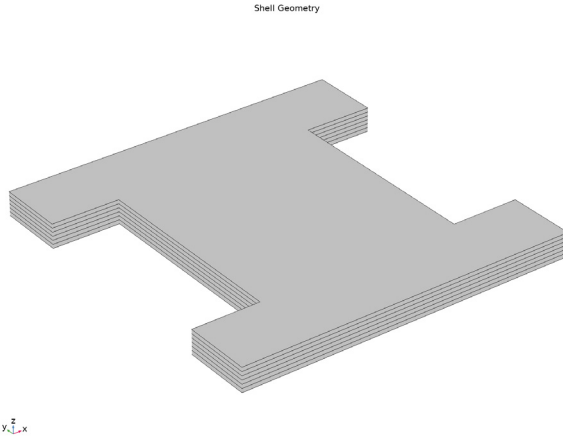

*Figure 2-19: 3D solid geometric representation (scaled in thickness direction) of a composite laminate having six layers.*

In addition to visualizing the stacking sequence of a laminate, visualization of the fiber draping direction on the physical geometry is also useful. A result template as shown in [Figure 2-20](#) is available in the Layered Shell and Shell interfaces.

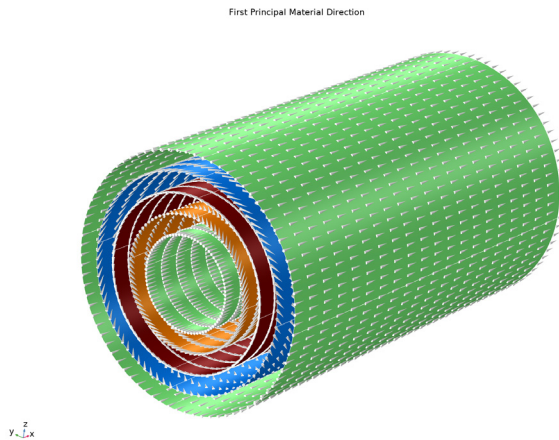

*Figure 2-20: First principal material direction showing the fiber draping direction in each layer of a composite cylinder.*

# Layer and Interface Selections

Once a layered material is defined, it is possible to use the layer information while setting up the selections in a physics interface and its different features.

The physics features can be of two, fundamentally different, types: Those who act on the layers themselves, and those who act on the interfaces between layers. The settings for these two types of features are slightly different.

## LAYER FEATURES

The physics interface and its layer features have a section named **Shell Properties**. The layer selections made in this section interact with the standard selections of geometrical objects (boundary, edges, or points) in order to provide a complete specification of where a material property or boundary condition is to be applied.

The default selections in the **Shell Properties** section differ between different physics features. This reflects the fact that some physics features (such as thermal expansion) are more likely to be applied to all layers, whereas other features (such as added mass) are more likely to be used for a single layer or interface.

The section always contains a checkbox named **Use all layers**. When selected, you cannot control individual layers; the contribution is given to all layers. All information is taken from the definitions made in the layered material features (**Layered Material Link**, **Layered Material Stack**, or **Single Layer Material**) under **Materials** in the current component. This means that a single physics node can accommodate several different stacking sequences. As geometrical selection, you can use any object selected in any of the layered material features.

When **Use all layers** is not selected, the **Layer** list is displayed. You can select

- Any **Layered Material Link** defined under **Materials** in the current component.
- Any **Layered Material Stack** defined under **Materials** in the current component.
- Any **Single Layer Material** defined under **Materials** in the current component.

If you select an individual **Layered Material Link**, **Layered Material Stack**, or **Single Layer Material**, you can only select geometrical objects which are part of the selections of that feature. In most cases, you will then get access to a list of checkboxes where you can further limit the contributions to individually selected layers to which this contribution is to be added.

## INTERFACE FEATURES

The interface features have a section named **Interface Selection**. The interface selection can be done by choosing from the following options:

- Top interface
- Bottom interface
- Exterior interfaces
- Interior interfaces
- All interfaces
- Selected interfaces

When **Selected interfaces** is chosen, the **Interface** list is displayed. You can select

- Any **Layered Material Link** defined under **Materials** in the current component.
- Any **Layered Material Stack** defined under **Materials** in the current component.
- Any **Single Layer Material** defined under **Materials** in the current component.

If you select an individual **Layered Material Link**, **Layered Material Stack**, or **Single Layer Material**, then you can only select geometrical objects which are part of the selections of that feature. In most cases, you will then get access to a list of checkboxes where you can further limit the contributions to individually selected interfaces to which this contribution is to be added.

## LAYER SELECTIONS

When a physics feature acts on layers, the interpretations of layer selections are:

- A boundary selection in the geometry corresponds to a domain contribution in the selected layers.
- An edge selection in the geometry corresponds to boundary contributions on the faces of the layers exposed to that edge.
- A point selection in the geometry corresponds to edge contributions on corners of the selected layers meeting at the selected point.

This is illustrated in [Figure 2-21](#) to [Figure 2-23](#) where the patch at the lower left is the actual shell, and the 3D sketch shows an expanded view of what it would represent in the physical world.

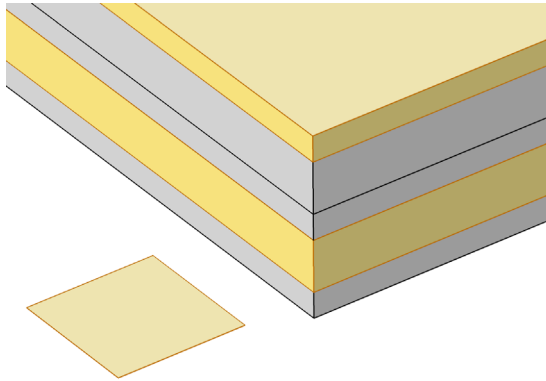

*Figure 2-21: Boundary selection with layers 2 and 5 selected.*

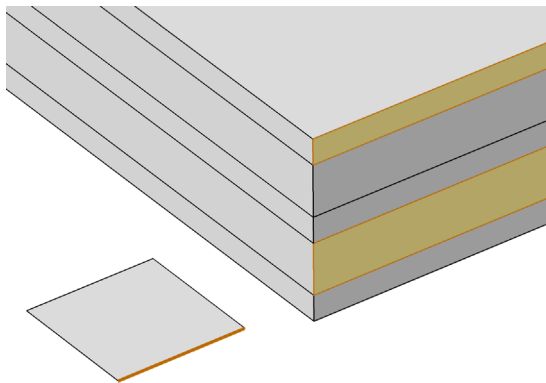

*Figure 2-22: Edge selection with layers 2 and 5 selected.*

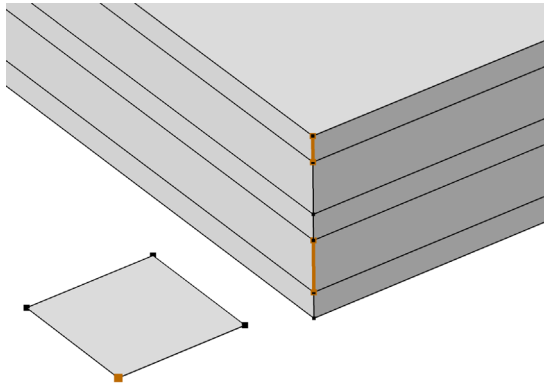

*Figure 2-23: Point selection with layers 2 and 5 selected.*

### **INTERFACE SELECTIONS**

When a physics feature acts on interfaces, the interpretations of interface selections are:

- A boundary selection in the geometry corresponds to boundary contributions on the selected interfaces.
- An edge selection in the geometry corresponds to edge contributions on the interface edges parallel to the selected edge.
- A point selection in the geometry corresponds to point contributions on the interface corners located at the selected point.

This is illustrated in [Figure 2-24](#) to [Figure 2-26](#) where the patch at the lower left is the actual shell, and the 3D sketch shows an expanded view of what it would represent in the physical world.

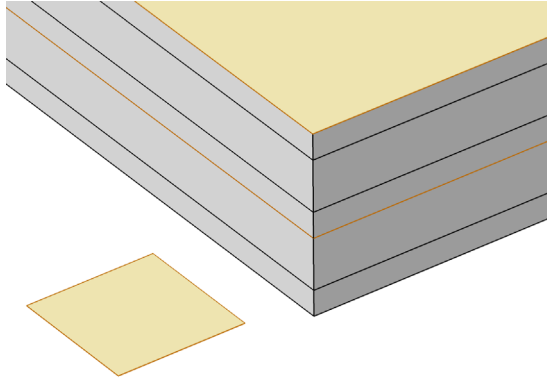

*Figure 2-24: Boundary selection with interfaces 'layer 2 - layer 3' and 'layer 5 up' selected.*

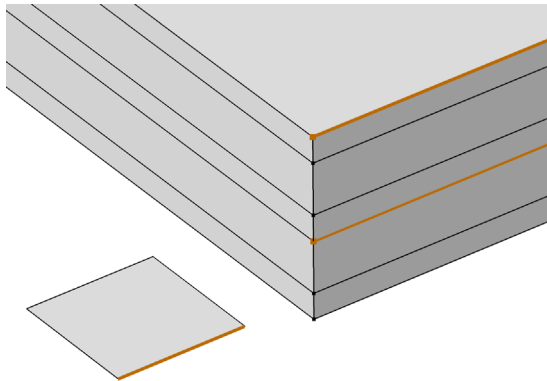

*Figure 2-25: Edge selection with interfaces 'layer 2 - layer 3' and 'layer 5 up' selected.*

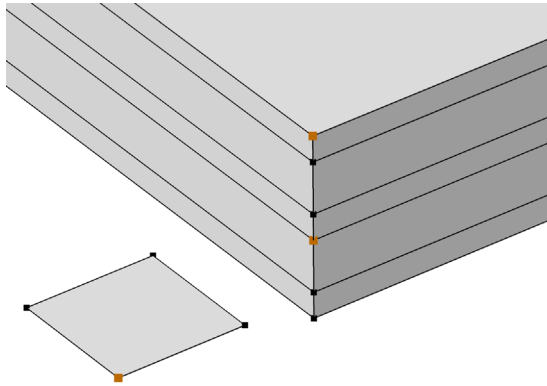

*Figure 2-26: Point selection with interfaces 'layer 2 - layer 3' and 'layer 5 up' selected.*

# Failure Modeling

In composite laminates, it is quite common to have different kinds of failure modes. Thus it becomes essential to perform various kinds of failure analyses for composite laminates.

In this section:

- [Failure Analysis](#)
- [Buckling Analysis](#)
- [Delamination Modeling](#)

## *Failure Analysis*

---

In COMSOL Multiphysics, both laminate theories allow computation of failure indices or safety factors based on the following criteria:

- von Mises Isotropic
- Tresca Isotropic
- Rankine Isotropic
- Saint-Venant Isotropic
- Jenkins Orthotropic
- Waddoups Orthotropic
- Tsai–Hill Orthotropic
- Hoffman Orthotropic
- Tsai–Wu Orthotropic
- Zinoviev Orthotropic
- Hashin–Rotem Orthotropic
- Hashin Orthotropic
- Puck Orthotropic
- LaRC03 Orthotropic
- Tsai–Wu Anisotropic

In addition to that, the ESL theory includes the following failure criteria:

- Azzi–Tsai–Hill Orthotropic

- Norris Orthotropic
- Modified Tsai–Hill Orthotropic

Add a **Safety** subnode to compute the safety factor for a given criterion. Additional built-in variables are available when multiple **Safety** subnodes are added. The combined safety factor, combined failure index, combined damage index, and combined margin of safety provide a conservative approach to safety assessment.



In the *Structural Mechanics Module User's Guide*:

- The [Safety](#) node
  - [Safety Factor Evaluation](#)
- 

### *Buckling Analysis*

---

Buckling of a composite laminate is a common phenomenon and also an important design consideration. It is crucial to design a composite laminate which can withstand compression or torsional buckling loads.

In COMSOL Multiphysics, both laminate theories can be used to compute the critical buckling load factor of a composite laminate.



In the *Structural Mechanics Module User's Guide*: [Linearized Buckling Analysis](#)

---

### *Delamination Modeling*

---

A composite laminate consists of many layers, glued or laminated together. Under different loading conditions, particularly impact loading, the bond between the two layers can break in a specific region.

Delamination initiation and propagation, and being able to predict how delaminated regions affect the response of a composite laminate, are important design considerations. In COMSOL Multiphysics, this can be modeled using the **Delamination** node in the Layered Shell interface. There are several different displacement and energy based cohesive zone models available, as well as different traction-separation laws. It is also possible to model contact between delaminated layers.



In the *Structural Mechanics Module User's Guide*: [Delamination](#)

---

# Structural Couplings

Composite laminates, modeled using layered shell elements, are often connected with solid or standard shell elements in different configurations to model real-world structures. The following structural couplings can be used to connect layered shell elements to solid or shell elements:

- Layered Shell — Shell Connection
- Layered Shell — Structure Cladding
- Layered Shell — Structure Transition

## *Layered Shell — Shell Connection*

---

This coupling is used to create models where a combination of the Layered Shell interface and the Shell interface are used for different layers in the same layup, thus both interfaces are active on the same boundary. This type of modeling (multiple model method) is efficient when some layers are thin, while other layers are significantly thicker.

## *Layered Shell — Structure Cladding*

---

This coupling is used to connect the top or bottom surface of layered shells to other shells, solids, or membranes. The coupling allows shared as well as parallel sets of boundaries.

## *Layered Shell — Structure Transition*

---

This coupling is used to connect edges of layered shells to other shells or to boundaries of solids. The coupling allows you to choose only some of the layers of the layered shells.

# Multiphysics Modeling

A composite laminate is most commonly designed based on structural requirements, but there are situations where other physical phenomena must be considered. There are two fundamentally different types of interactions between the mechanics of a laminate and other processes:

- Some physical processes occur inside the laminate. Examples are heat flux, electric currents, and diffusion processes.
- A laminate may act as a boundary of a 3D domain in which, for example, fluid flow is present.

## *Coupling to Electrical and Thermal Modeling*

---

In some applications where electrical or thermal effects are significant, it can be important to design the laminate based on a combined response. The layered material technology in COMSOL Multiphysics allows you to use different physics interfaces in the same layered material, and it is possible to solve for all the physical phenomena simultaneously, using couplings between them.

From a structural design point of view, either laminate theory can be used together with electrical and thermal modeling of composite laminates. An example is Joule heating and thermal expansion of a composite laminate.

- The two multiphysics interfaces Thermal Stress, Layered Shell and Thermal Stress, Shell can be used to couple layered shell and shell elements to physics interfaces for heat transfer analysis.
- The Piezoelectricity, Layered Shell multiphysics interface can be used to couple the Layered Shell interface and the Electric Currents in Layered Shells interface to model piezoelectric layers in a composite laminate.
- The Piezoresistivity, Layered Shell multiphysics interface can be used to couple the Layered Shell interface and the Electric Currents in Layered Shells interface to model piezoresistive layers in a composite laminate.

## *Coupling to Fluid and Acoustics Modeling*

---

You can model the interactions of composite laminates with a surrounding fluid, for fluid-structure interaction or acoustic applications. Models based on the ESL theory

are simplified and computationally fast. In comparison, models based on the layerwise theory more accurately capture the interaction of the composite laminate with its surrounding fluid domains, at an increased computational expense.

### *Coupling to Darcy's Law for Poroelasticity Modeling*

---

You can model the flow within porous composite laminates and its interaction with the structural shells. This interaction is supported by structural shell models based on the layerwise theory. The coupling occurs on the boundary level, where the pore pressure from the Layered Darcy's Law interface acts as a load for the Layered Shell interface, causing swelling or shrinking. Changes in volumetric strain affect the pore space, acting as a mass source or sink in Darcy's Law.

### *Coupling to Lumped Mechanical System Modeling*

---

You can connect the finite element model obtained from Layered Shell interface to a lumped model obtained from Lumped Mechanical System interface using the Lumped-Structure Connection multiphysics coupling. The displacements obtained from the finite element model at the connection points are transferred to the lumped model. Similarly, the reaction forces obtained from the lumped model are applied to the finite element model.

# Results Evaluation

Composite laminates are defined on boundaries together with a layered material attached to them. As composite laminates are in general anisotropic, and in general heterogeneous in the through-thickness direction, evaluating results on the reference surface alone is usually not sufficient. You will need to evaluate results in each layer, as well as in the through-thickness direction.

In addition to the standard result presentation tools, COMSOL Multiphysics offers specialized methods for evaluating and plotting results in composite laminates:

- [Layered Material Dataset](#)
- [Layered Material Slice Plot](#)
- [Through Thickness Plot](#)
- [Special Variables and Operators](#)

## *Layered Material Dataset*

---

Even though the composite laminate is modeled as a surface (2D) geometry, you can visualize the results on a geometry with finite thickness. For this, you use the **Layered Material** dataset.

The aspect ratio of a laminate is often high, so it is difficult to visualize variations in the thickness direction. For this reason, the **Layered Material** dataset provides an option to scale the geometry in the thickness direction.

Using this dataset, you can plot the results in two ways:

- Plots can be done on a full 3D geometry.
- You can create slices in the shell at different levels. The slices can be placed at mesh vertices in the thickness direction, at layer midplanes, or at interfaces.

Below is an example of how a thin composite laminate with two layers can be visualized. The geometry is a cylinder which is viewed along its axis. In [Figure 2-27](#), the following evaluation and plotting modes are shown:

- Case A: The geometry. This is what you see if you do not use the specialized dataset.
- Case B: Layered material dataset with true thickness (the default). It shows a solid representation, and you would need to zoom in to resolve details.

- Case C: Layered material dataset with 20x scaling in the thickness direction.
- Case D: Layered material dataset with 20x scaling in the thickness direction, and slices at the mesh vertices.
- Case E: Layered material dataset with 20x scaling in the thickness direction, and slices at the layer midplanes.
- Case F: Layered material dataset with 20x scaling in the thickness direction, and separate slices at the interfaces.

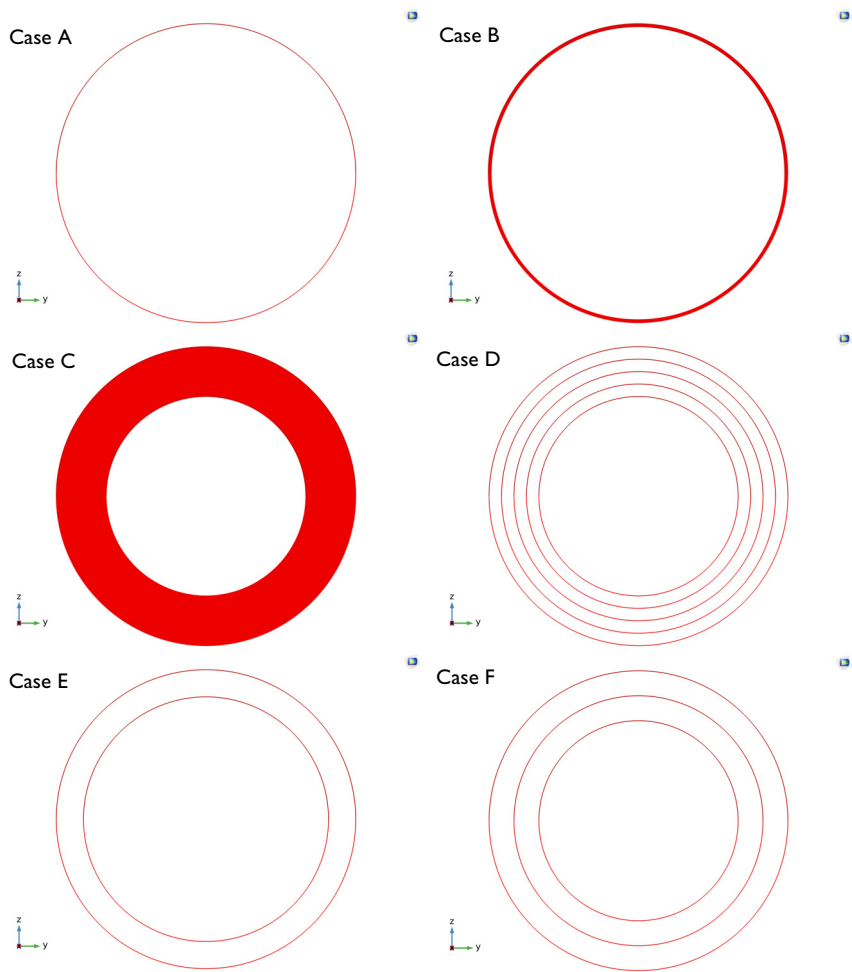

*Figure 2-27: The modeled geometry and various ways to use a Layered Material dataset to evaluate results in a layered material.*



In the *COMSOL Multiphysics Reference Manual*: The [Layered Material dataset](#)

## Layered Material Slice Plot

As described in the previous section, you can generate slice plots using the layered material dataset. You can also use a **Layered Material Slice** plot which allows you to plot many layers or interface. You can optionally arrange them in a linear or rectangular array, and add layer numbers to the plot automatically. The plot is also useful in the following cases:

- When you want to create a slice only in one or a few selected layers.
- When you want to create a slice plot through some or all layers, but not necessarily perpendicularly to the thickness direction.
- When you want to examine a particular layer in detail, and want to plot the results at a position within the layer, away from the midplane.

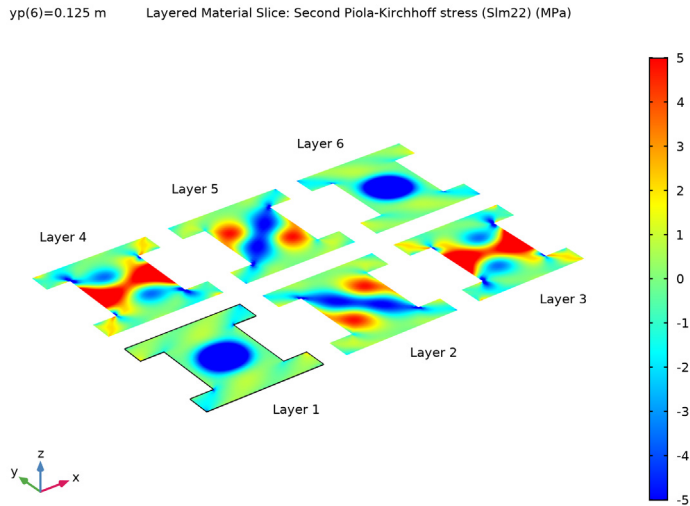

Figure 2-28: Example of a Layered Material Slice plot, where the Second Piola-Kirchhoff stress is plotted in all the layers of a laminate with six layers ( $[30/-45/75/-75/45/30]$ ).



In the *COMSOL Multiphysics Reference Manual*: The [Layered Material Slice](#) plot.

## Through Thickness Plot

Composite laminates are in general heterogeneous in the thickness direction. It is often desirable to plot the variation of a quantity in the through-thickness direction, at certain locations on the boundary.

To this end, you can use a **Through Thickness** plot in which any quantity can be plotted against laminate thickness. You can select one or more geometric points on the boundary, or optionally create cut point datasets. It is also possible to specify point coordinates directly.

The result quantity is plotted on the  $x$ -axis, and the thickness coordinate is plotted on the  $y$ -axis. An example of a through-thickness plot is shown in [Figure 2-29](#).

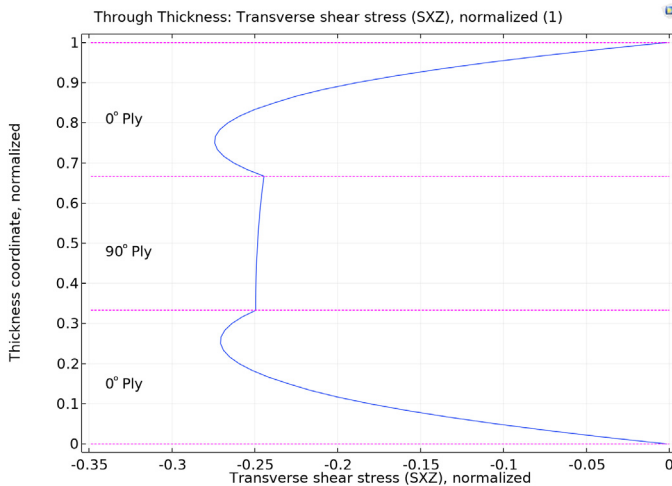

Figure 2-29: Example of a Through Thickness plot, where the transverse shear stress is plotted at a particular point on a composite laminate with three layers ([0/90/0]).



In the *COMSOL Multiphysics Reference Manual*: The [Through Thickness](#) plot.

## Special Variables and Operators

---

There are special variables available in the extra dimension. These variables can be used in the physics and in postprocessing, and work in connection with a **Layered Material** dataset. See [Layered Material Dataset](#).

- `<phys>.xd`: The extra dimension coordinate is wrapped into a physics interface variable, for example `shell.xd`. The coordinate varies from 0 at the bottom to the laminate thickness  $d$  at the top.
- `<phys>.xd_re1`: The relative extra dimension coordinate that varies between 0 at the bottom to 1 at the top.
- `<phys>.z1`: The extra dimension coordinate that varies between  $-d/2$  at the bottom to  $d/2$  at the top.
- `<phys>.num`: The layer number that is 1 for the bottom layer and  $N$  for the top layer.

There are special operators available that can handle common operations in the extra dimension. These operators work with a **Solution** dataset.

- `<phys>.atxd1(xdim_location,expr)`: Extra dimension evaluation of `expr` on 1-dimensional entity at given extra dimension coordinate. The operator can be used to access any variable defined on a layer level product selection at a particular extra dimension location.
- `<phys>.atxd0(xdim_location,expr)`: Extra dimension evaluation of the expression on 0-dimensional entity at given extra dimension coordinate. The operator can be used to access any variable defined on an interface-level product selection at a particular extra dimension location.
- `<phys>.xdintopall(expr)`: Extra dimension integration of the expression on 1-dimensional entity. The expression must be wrapped inside the mean or extra dimension mean operators if it is a variable defined on the higher dimension.
- `<phys>.xdintopallint(expr)`: Extra dimension integration of the expression on 0-dimensional entity. The expression must be wrapped inside the mean or extra dimension mean operators if it is a variable defined on the higher dimension.
- `<phys>.xdsumbnd(expr)`: Extra dimension summation of the expression on a boundary. Useful to compute reaction forces and moments on the specific boundary.
- `<phys>.xdsumedg(expr)`: Extra dimension summation of the expression in an edge. Useful to compute reaction forces and moments in the specific edge.

- `<phys>.xdsumpnt(expr)`: Extra dimension summation of the expression in a point. Useful to compute reaction forces and moments in the specific point.
- `<phys>.xdavgbnd(expr)`: Extra dimension average of the expression on a boundary.
- `<phys>.xdavgedg(expr)`: Extra dimension average of the expression in an edge.
- `<phys>.xdavgpnt(expr)`: Extra dimension average of the expression in a point.



---

See [Solution](#), [Layered Material](#), [Layered Material Slice](#), and [Through Thickness](#) in the *COMSOL Multiphysics Reference Manual* for details about the **Solution** dataset, the **Layered Material** dataset, and slice and through-thickness plots in layered materials.

[Using Extra Dimensions](#) in the *COMSOL Multiphysics Reference Manual*.

---

# I n d e x

- A** about composite materials 16
  - about laminated composite shells 19
  - Application Libraries window 12
- B** benefits of composites 18
  - buckling analysis 59
- C** classification of composites 16
  - composite materials modeling 15
  - constituents of a lamina 23
- D** delamination modeling 59
  - documentation 11
- E** emailing COMSOL 13
  - esl theory 28
- F** failure modeling 58
  - fiber arrangement 19
  - FRP composites 17
- H** homogenization 24
- I** internet resources 10
- K** knowledge base, COMSOL 13
- L** laminate coordinate system 39
  - laminated shell theories 28
  - layer selections 52
  - layered material dataset 64
  - layered material slice plot 67
  - layered material stack 45
  - layered materials 35
  - layered membrane 33
  - layerwise theory 30
- M** macromechanics 26
  - micromechanics 23
  - MPH files 12
  - multiphysics modeling 62
  - multiscale analysis 21
- P** ply based modeling 47
  - preview plots 36
- R** results evaluation 64
- S** saving and loading layered materials 49
  - stacking sequence 20
  - structural couplings 61
  - sweeping over layered materials 49
- T** technical support, COMSOL 13
  - through thickness plot 68
  - types of laminate 21
- V** variable thickness layer 46
  - visualizing 3D geometry and fiber draping 50
- W** websites, COMSOL 13

