

INTRODUCTION TO CFD Module

Introduction to the CFD Module

© 1998–2025 COMSOL

Protected by patents listed on www.comsol.com/patents, or see Help > About COMSOL Multiphysics on the File menu in the COMSOL Desktop for less detailed lists of U.S. Patents that may apply. Patents pending.

This Documentation and the Programs described herein are furnished under the COMSOL Software License Agreement (www.comsol.com/sla) and may be used or copied only under the terms of the license agreement.

COMSOL, the COMSOL logo, COMSOL Multiphysics, COMSOL Desktop, COMSOL Compiler, COMSOL Server, and LiveLink are either registered trademarks or trademarks of COMSOL AB. All other trademarks are the property of their respective owners, and COMSOL AB and its subsidiaries and products are not affiliated with, endorsed by, sponsored by, or supported by those trademark owners. For a list of such trademark owners, see www.comsol.com/trademarks.

Version: COMSOL 6.4

Contact Information

Visit the Contact COMSOL page at www.comsol.com/contact to submit general inquiries or search for an address and phone number. You can also visit the Worldwide Sales Offices page at www.comsol.com/contact/offices for address and contact information.

If you need to contact Support, an online request form is located on the COMSOL Access page at www.comsol.com/support/case. Useful links:

- Support Center: www.comsol.com/support
- Product Download: www.comsol.com/product-download
- Product Updates: www.comsol.com/product-update
- COMSOL Blog: www.comsol.com/blogs
- Discussion Forum: www.comsol.com/forum
- Events: www.comsol.com/events
- COMSOL Video Gallery: www.comsol.com/videos
- Support Knowledge Base: www.comsol.com/support/knowledgebase
- Learning Center: www.comsol.com/support/learning-center

Part number: CM021302

Contents

Introduction	5
Aspects of CFD Simulations	6
The CFD Module Physics Interfaces	11
Physics Interface Guide by Space Dimension and Study Type	22
Tutorial Model — Backstep	41
Model Geometry	41
Domain Equations and Boundary Conditions	41
Results	42
Tutorial Model — Water Purification Reactor.	51
Model Geometry	52
Domain Equations and Boundary Conditions	52
Notes About the Implementation	53
Results	53
Reference.	54

Introduction

The CFD Module is used by engineers and scientists to understand, predict, and design for fluid flow in closed and open systems. At a given cost, these types of simulations typically lead to new and better products and improved operations of devices and processes compared to purely empirical studies involving fluid flow. As part of an investigation, simulations give accurate estimates of flow patterns, pressure losses, forces on submerged objects, temperature distributions, and variations in fluid composition within a system.

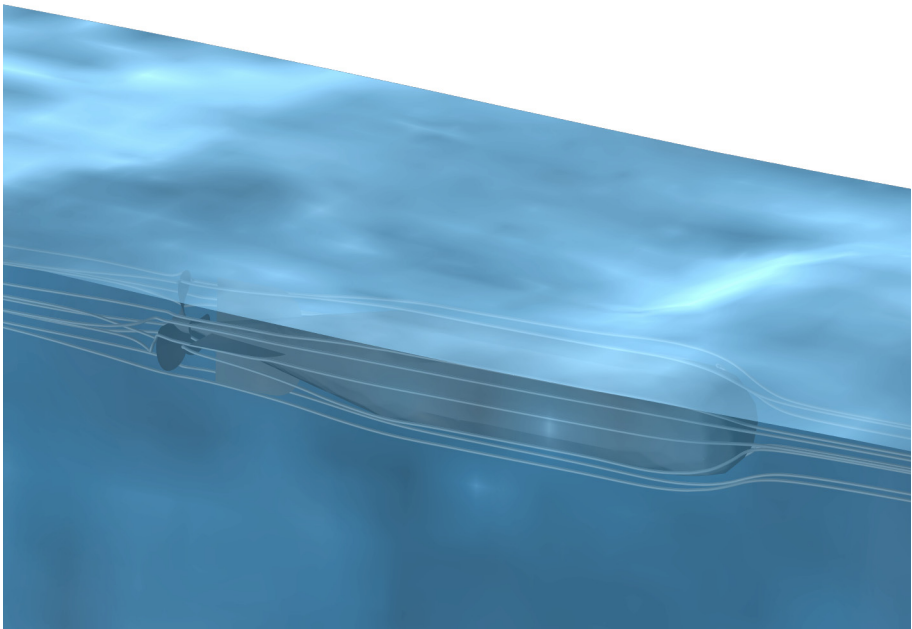

Figure 1: Streamlines and free-surface deformation for the flow around a torpedo.

The CFD Module's general capabilities include modeling stationary and time-dependent fluid flow problems in two- and three-dimensional spaces. Formulations for different types of flow are predefined in a number of Fluid Flow interfaces, which allow you to set up and solve a variety of fluid-flow problems. These physics interfaces define a fluid-flow problem using physical quantities, such as velocity and pressure, and physical properties, such as viscosity. The Fluid Flow interfaces cover a wide range of flows, such as laminar and turbulent single-phase, multiphase, nonisothermal, and reacting flows.

The physics interfaces build on conservation laws for momentum, mass, and energy. These laws are expressed in terms of partial differential equations, which are solved by the module together with the specified initial and boundary conditions. The equations are solved using stabilized finite element formulations for fluid flow in combination with damped Newton methods and, for time-dependent problems, different time-dependent solver algorithms. The results are presented in the Graphics window through predefined plots relevant for CFD, expressions of physical quantities that you can freely define, and tabulated derived quantities (for example, average pressure on a surface or drag coefficients) obtained from a simulation.

The workflow in the CFD Module is quite straightforward and is described by the following steps: define the geometry, select the fluid to be modeled, select the type of flow, define boundary and initial conditions, define the finite element mesh, select a solver, and visualize the results. All these steps are accessed from the COMSOL Desktop[®]. The mesh and solver steps are usually carried out automatically using default settings that are tuned for each specific Fluid Flow interface.

The CFD Module Application Library describes the Fluid Flow interfaces and their different features through tutorial and benchmark examples for the different types of flow. Here you can find models of industrial equipment and devices, tutorials for practice, and benchmark applications for verification and validation of the Fluid Flow interfaces.

This introduction is intended to give you an accelerated start in CFD application building. It contains examples of the typical use of the module, a list of all the Fluid Flow interfaces including a short description of each, and two tutorial models, [Tutorial Model — Backstep](#) and [Tutorial Model — Water Purification Reactor](#), to introduce the workflow.

Aspects of CFD Simulations

The physical nature of a flow field may be characterized by a set of dimensionless numbers such as the Reynolds number, the Mach number, and the Grashof number. A great deal of information about the flow field can be gained by analyzing these numbers.

The Reynolds number, for example, expresses the ratio of the inertia forces to the viscous (internal friction) forces. For vanishingly small values of the Reynolds number, the inertia forces are negligible and the flow is reversible, in the sense that reversed boundary conditions lead to reversed flow. The energy dissipation is immediate. As the Reynolds number increases, viscous effects become more and more confined to boundaries, internal shear layers, and wakes. The relative size and other characteristics of such regions are determined by the Reynolds number.

Eventually, for very large values of the Reynolds number, the flow becomes fully turbulent. In contrast to laminar flow at high Reynolds numbers, viscous dissipation is active everywhere in a turbulent flow field but is most effective on the smallest flow structures. The energy is transferred from the large-scale flow structures to the small-scale flow structures through a cascade of eddies. Due to the requirement of resolving all these flow scales, direct numerical simulation of industrially relevant turbulent flows is currently not a feasible approach. Instead, turbulence models are applied when analyzing these flows. For very small values of the Reynolds number, the CFD Module offers the Creeping Flow interface; for intermediate values, the Laminar Flow interface; and for large values, the Turbulent Flow, Large Eddy Simulation, and Detached Eddy Simulation interfaces.

You can use the Two-Phase Flow and Three-Phase Flow interfaces in the Multiphase Flow branch to model moving, deformable interfaces between phases, separating two or three different fluids. The other physics interfaces in this branch are mainly intended for modeling suspensions of many particles, droplets, or bubbles. Among the latter group, the Euler–Euler Model interface is able to handle high concentration levels with frequent collisions as well as transients in the relative velocity between the phases (that is, nonvanishing ratios of the particle relaxation time to the macroscopic flow time scale). The Phase Transport, Mixture Model physics interface can be used to model transport of multiple dispersed phases.

Temperature variations caused by heat transfer, compression work, or work done by friction forces result in an inhomogeneous density field which may trigger thermal convection. The significance of thermally induced buoyancy forces in the momentum equation is characterized by the ratio of the Grashof number to the square of the Reynolds number (for large Reynolds numbers), or of the Grashof number to the Reynolds number (for small Reynolds numbers). For nonvanishing values of this ratio, the Nonisothermal Flow interfaces are available.

The Mach number expresses the ratio of the speed of the fluid to the speed of sound of the flowing medium. This dimensionless number measures the relevance of compressible effects in the flow field, predicting occurrences of shock waves and rarefaction waves. For Mach numbers greater than 0.3, the laminar, turbulent, and Euler equations versions of the High Mach Number Flow interfaces are available.

The Shallow Water Equations interface and the Thin-Film Flow interfaces provide simplified, depth-averaged formulations for free-surface flows and lubrication applications, respectively.

For reacting flow and flow in porous media, the Chemical Species Transport branch and the Porous Media and Subsurface Flow branch are available.

Contrary to experimental analyses, which are most often performed in a laboratory where measurements are limited to a small number of points, a CFD simulation

gives a “big picture” view of the flow field. A qualitative interpretation of the flow and pressure fields is usually the first step toward creating or improving a design.

Figure 2 shows the flow field around a solar panel. The presence of a wake in front of the panel, caused by another panel in the solar power plant, may induce lift forces that would not be present if the panel were analyzed alone.

Three-dimensional graphics such as surface, streamline, ribbon, arrow, and particle-tracing plots, as well as animations that include any combination of the aforementioned features, are examples of tools you can use for qualitative studies.

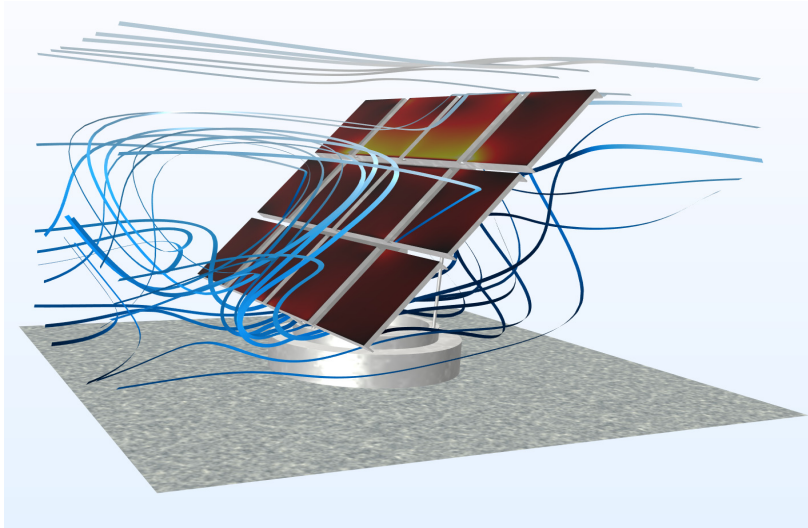

Figure 2: Turbulent fluid flow around a solar panel solved using the CFD Module.

In addition to the qualitative “big picture” view, simulations performed with the CFD Module give accurate quantitative estimates of properties of the flow field, such as the average flow at a given pressure difference, the drag and lift coefficients around submerged bodies, or the air quality in a ventilated room.

Figure 3 and Figure 4 show the velocity and pressure fields in a cyclone simulation. The centrifugal force, which is proportional to the square of the azimuthal velocity component and the inverse of the radius, can be used to assess the separation efficiency in the cyclone. In addition to separation and fractionation, cyclones may be used for deflocculation, which can be modeled using the turbulent dissipation rate.

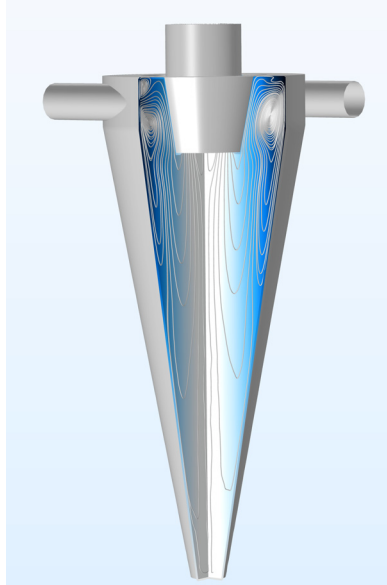

Figure 3: In-plane streamlines and pressure field for the flow field in a cyclone simulated using the v_2 - f turbulence model.

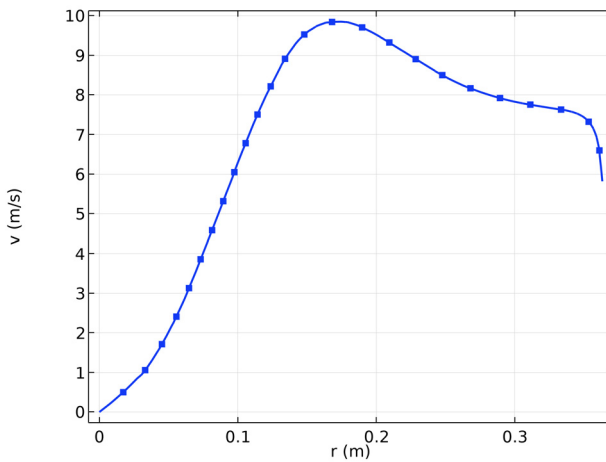

Figure 4: Azimuthal velocity component below the vortex finder. The characteristic profile due to a free vortex can be observed for larger radii.

The CFD Module has a vast range of tools for evaluating quantitative results. For example, it comes with built-in functionality for evaluating surface and volume

averages, maximum and minimum values, and derived values (functions and expressions of the solution), as well as for generating tables and xy plots. Derived values such as drag and lift coefficients and other values relevant for CFD are easily defined.

Qualitative studies typically form the basis for understanding, which in turn can spark new ideas. These ideas can then lead to significant improvements to products and processes, often in quantum leaps. Quantitative studies, on the other hand, form the basis for optimization and control, which can also greatly improve products and processes but usually do so through a series of many smaller steps.

The CFD Module Physics Interfaces

The Fluid Flow interfaces in this module are based on the laws for conservation of momentum, mass, and energy in fluids. The different flow models contain different combinations and formulations of the conservation laws that apply to the physics of the flow field. These laws of physics are translated into partial differential equations and are solved together with the specified initial and boundary conditions.

A physics interface defines a number of features. These features are used to specify the fluid properties, initial conditions, boundary conditions, and possible constraints. Each feature represents an operation describing a term or condition in the conservation equations. Such a term or condition can be defined on a geometric entity of the component, such as a domain, boundary, edge (for 2D components), or point.

Figure 5 shows the Model Builder window, including a Laminar Flow interface, and the Settings window for the selected Fluid Properties 1 feature node. The Fluid Properties 1 node adds the marked terms to the component equations in a selected geometry domain. Furthermore, the Fluid Properties 1 feature may link to the Materials feature node to obtain physical properties such as density and dynamic viscosity, in this case the fluid properties of water. The fluid properties, defined by the *Water, liquid* material, can be functions of the modeled physical quantities, such as pressure and temperature. In the same way, the Wall 1 node adds the boundary conditions at the walls of the fluid domain.

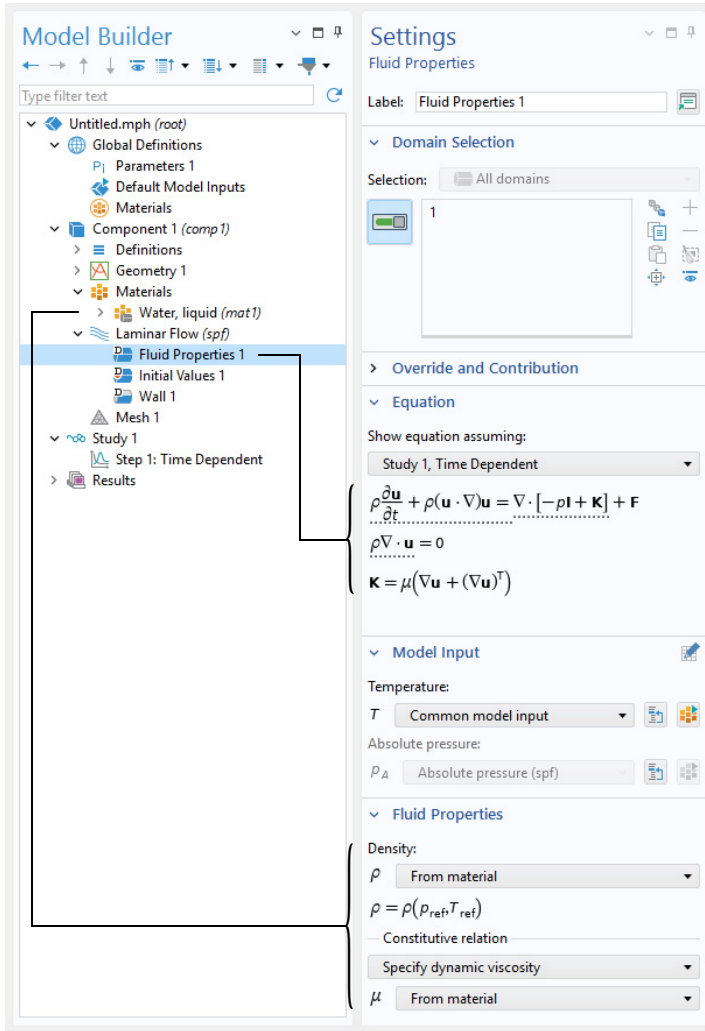

Figure 5: The Model Builder window, including a Laminar Flow interface (left), and the Settings window with the Fluid Properties section for the selected feature node (right). The Equation section in the Settings window shows the component equations and the terms added by the Fluid Properties 1 node. The added terms are underlined with a dotted line. The brackets and lines also explain the link between the Materials node and the values for the fluid properties.

The CFD Module includes a large number of Fluid Flow interfaces for different types of flow. It also includes Chemical Species Transport interfaces for reacting flows in multicomponent solutions and physics interfaces for heat transfer in solids, fluids, and porous media, found under the Heat Transfer branch.

Figure 6 shows the Fluid Flow interfaces as they are displayed when you add a physics interface in 3D. (See also [Physics Interface Guide by Space Dimension and Study Type](#) for further information.) A short description of the physics interfaces follows.

- > AC/DC
 - > Acoustics
 - > Chemical Species Transport
 - Transport of Diluted Species (tds)
 - Transport of Concentrated Species (tcs)
 - Transport of Diluted Species in Porous Media (tds)
 - Transport of Concentrated Species in Porous Media (tcs)
 - > Reacting Flow
 - Laminar Flow, Diluted Species
 - Laminar Flow, Concentrated Species
 - > Turbulent Flow, Diluted Species
 - > Turbulent Flow, Concentrated Species
 - > Reacting Flow in Porous Media
 - Transport of Diluted Species
 - Transport of Concentrated Species
 - > High Mach Number Reacting Flow
 - Laminar Flow, Diluted Species
 - > Turbulent Flow, Diluted Species
 - > Dispersed Two-Phase Flow with Species Transport
 - Laminar Flow
 - > Turbulent Flow
 - > Fluid Flow
 - > Heat Transfer
 - Heat Transfer in Solids (ht)
 - Heat Transfer in Fluids (ht)
 - Heat Transfer in Solids and Fluids (ht)
 - > Conjugate Heat Transfer
 - Laminar Flow
 - > Turbulent Flow
 - > Electromagnetic Heating
 - > Porous Media
 - > Structural Mechanics
 - Solid Mechanics (solid)
 - > Fluid-Structure Interaction
 - Fluid-Solid Interaction, Fixed Geometry
 - Thin-Film Damping
 - Solid-Thin-Film Damping
 - > Two-Phase Flow, Phase Field
 - > Mathematics
 - > Δu PDE Interfaces
 - > $\frac{d}{dt}$ ODE and DAE Interfaces
 - > Optimization and Sensitivity
 - > ∇^2 Classical PDEs
 - > Moving Interface
 - Level Set (ls)
 - Level Set in Porous Media (ls)
 - Phase Field in Fluids (pf)
 - Phase Field Thin-Film Flow (pftff)
 - Ternary Phase Field (terpf)
 - > Deformed Mesh
 - > Wall Distance (wd)
 - > Curvilinear Coordinates (cc)
- > Fluid Flow
 - > Single-Phase Flow
 - Creeping Flow (spf)
 - Laminar Flow (spf)
 - > Turbulent Flow
 - Large Eddy Simulation
 - Detached Eddy Simulation
 - > Rotating Machinery, Fluid Flow
 - Viscoelastic Flow (vef)
 - > Potential Flow
 - > Multiphase Flow
 - Bubbly Flow
 - Mixture Model
 - Euler-Euler Model
 - Phase Transport Mixture Model
 - Nonisothermal Mixture Model
 - Two-Phase Flow, Moving Mesh
 - > Two-Phase Flow, Level Set
 - > Two-Phase Flow, Phase Field
 - > Two-Phase Thin-Film Flow, Phase Field
 - > Three-Phase Flow, Phase Field
 - > Phase Transport
 - > Porous Media and Subsurface Flow
 - Brinkman Equations (br)
 - Darcy's Law (dl)
 - Multiphase Flow in Porous Media
 - Multiphase Free and Porous Media Flow
 - Two-Phase Darcy's Law (tpdl)
 - Free and Porous Media Flow, Brinkman (fp)
 - Free and Porous Media Flow, Darcy
 - Thin-Film and Porous Media Flow
 - > Nonisothermal Flow
 - Laminar Flow
 - > Turbulent Flow
 - Large Eddy Simulation
 - > Rotating Machinery, Nonisothermal Flow
 - Brinkman Equations
 - Viscoelastic Flow
 - > High Mach Number Flow
 - High Mach Number Flow, Laminar (hmnf)
 - > Turbulent Flow
 - Compressible Euler Equations (cee)
 - > Rotating Machinery, High Mach Number Flow
 - > Fluid-Structure Interaction
 - Fluid-Solid Interaction, Fixed Geometry
 - > Two-Phase Flow, Phase Field
 - Thin-Film Flow
 - Thin-Film Flow (tff)

Figure 6: The physics interfaces for the CFD Module as shown in the Model Wizard (left: the full set of physics interfaces with the included physics interfaces in the Chemical Species Transport, Heat Transfer, Structural Mechanics, and Mathematics branches expanded; right: the fully expanded Fluid Flow branch).

SINGLE-PHASE FLOW

The Creeping Flow interface (\equiv) approximates the Navier–Stokes equations for very low Reynolds numbers. This is often referred to as Stokes flow and is applicable when viscous effects are dominant, such as in very small channels or microfluidics devices.

The Laminar Flow interface (\equiv) is primarily applied to flows at low to intermediate Reynolds numbers. This physics interface solves the Navier–Stokes equations for incompressible, weakly compressible, and compressible flows (up to Mach 0.3). The Laminar Flow interface also allows for simulation of non-Newtonian fluids.

The physics interfaces under the Turbulent Flow branch (\approx) model flows at high Reynolds numbers. These physics interfaces solve the Reynolds-averaged Navier–Stokes (RANS) equations for the averaged velocity and pressure fields. The turbulent flow interfaces are divided into two categories, eddy-viscosity models (EVM) and Reynolds-stress models (RSM).

There are several eddy-viscosity models available—two algebraic models, the Algebraic γ Plus and L-VEL models, and seven transport-equation models, including a standard k - ϵ model, the Realizable k - ϵ model, a k - ω model, an SST (Shear Stress Transport) model, a low Reynolds number k - ϵ model, the Spalart–Allmaras model, and the ν 2-f model. Similarly to the Laminar Flow interface, incompressible flow is selected by default.

The Algebraic γ Plus and L-VEL models are so-called enhanced viscosity models. The turbulent viscosity is computed from the local distance to the nearest wall. For this reason, the algebraic models are best suited for internal flows, such as in electronic cooling applications. Algebraic models are computationally economical and more robust but, in general, less accurate than transport-equation models.

Among the transport-equation eddy-viscosity models, the standard k - ϵ model is the most widely used because it often is a good compromise between accuracy and computational cost (that is, memory and CPU time). The Realizable k - ϵ model is similar to the standard k - ϵ model but has built-in realizability constraints, resulting in improved performance for certain flows, such as turbulent jets. The k - ω model is an alternative to the standard k - ϵ model and often gives more accurate results, especially in recirculation regions and close to solid walls. However, the k - ω model is also less robust than the standard k - ϵ model.

The SST model combines the robustness of the k - ϵ model with the accuracy of the k - ω model, making it applicable to a wide variety of turbulent flows. The Low Reynolds number k - ϵ model is more accurate than the standard k - ϵ model, especially close to walls.

The Spalart–Allmaras model is specifically designed for aerodynamic applications, such as flow around wing profiles, but is also widely used in other applications due to its high robustness and reasonable accuracy.

In the v_2 - f model, the turbulent viscosity is based on the wall-normal velocity fluctuations, whereby wall blockage effects and low Reynolds number effects are captured separately. The v_2 - f model also includes nonlocal effects of the fluctuating pressure on the turbulent fields. Higher resolution is needed in the near-wall region for the SST model, the Low Reynolds number k - ϵ model, the Spalart–Allmaras model, and the v_2 - f model. Thus, the better accuracy provided by these models comes at a higher computational cost.

There are three Reynolds-stress models—the Wilcox R - ω model, the SSG-LRR (Speziale–Sarkar–Gatski/Lauder–Reece–Rodi) model and the Elliptic Blending R - ϵ model. All three models solve transport equations for the six components of the symmetric Reynolds-stress tensor, and for the specific turbulence dissipation rate ω (Wilcox R - ω and SSG-LRR) or the turbulence dissipation rate (Elliptic Blending R - ϵ), which enables accurate prediction of secondary flows.

The physics interfaces under the Large Eddy Simulation branch () also model flows at high Reynolds numbers. For these interfaces, the larger unsteady, three-dimensional eddies are fully resolved, whereas the smaller eddies are modeled. The dependent variables, velocity and pressure, are divided into resolved and unresolved scales and are substituted into the Navier–Stokes and continuity equations. The additional stress terms involving the unresolved scales are modeled in various ways in the three different interfaces under this branch. For the Residual-Based Variational Multiscale (RBVM) interface and the Residual-Based Variational Multiscale with Viscosity (RBVMWV) interface, the unresolved scales are modeled in terms of the equation residuals, which means that, in the limit when all scales are resolved, the simulation reverts to a direct numerical simulation (DNS) of the Navier–Stokes and continuity equations. The third interface uses a Smagorinsky term to model the effect of the unresolved Reynolds stress on the smallest resolved scales. The Large Eddy Simulation interfaces are applicable to three-dimensional, time-dependent flows.

Under the Detached Eddy Simulation branch () interfaces combining RANS modeling in the near-wall region with LES modeling in the bulk, can be found. All three interfaces in this branch apply the Spalart–Allmaras RANS model to compute the turbulent viscosity in the near-wall region. There are three choices for the LES modeling; the RBVM method, the RBVMWV method, and the Smagorinsky method. The Detached Eddy Simulation interfaces are applicable to three-dimensional, time-dependent flows.

The Rotating Machinery interfaces () combine the Single-Phase Flow interfaces and a Rotating Domain node under Moving Mesh, and are applicable to fluid-flow problems where one or more of the boundaries rotate, for example

in mixers and around propellers. These physics interfaces support incompressible, weakly compressible, and compressible (Mach < 0.3) flows, laminar Newtonian and non-Newtonian flows, and turbulent flow using the standard k - ϵ model or either of the two algebraic turbulence models (Algebraic γ Plus or L-VEL).

The Viscoelastic Flow interface () is used to simulate incompressible isothermal flow of viscoelastic fluids. It solves the continuity equation, the momentum equation, and a constitutive equation that defines the elastic stresses. There are three predefined models for the elastic stresses: Oldroyd-B, FENE-P, and Giesekus.

The Potential Flow interfaces () are applicable to incompressible or compressible irrotational flows. They can also be used to find initial values for the other fluid-flow interfaces.

MULTIPHASE FLOW



The physics interfaces under the Bubbly Flow branch () model two-phase flow where the fluids form a gas–liquid mixture, and the content of the gas is less than 10%. There is support for both laminar flow and turbulent flow using extended versions of the turbulence models that account for bubble-induced turbulence. For laminar flow, the physics interface supports non-Newtonian liquids. The Bubbly Flow interfaces also allow for mass transfer between the two phases.





The physics interfaces under the Mixture Model branch () are similar to the Bubbly Flow interfaces but assume that the dispersed phase consists of solid particles or liquid droplets. The continuous phase has to be a liquid. There is support for both laminar flow and turbulent flow. The Mixture Model interfaces also allow for mass transfer between the two phases.

The Euler–Euler Model interface () for two-phase flow is able to handle the same cases as the Bubbly Flow and Mixture Model interfaces but is not limited to low concentrations of the dispersed phase. In addition, the Euler–Euler Model interface can handle large differences in density between the phases, such as the case of solid particles in air. This makes the model suitable for simulations of, for example, fluidized beds. There is support for both laminar flow and turbulent flow using either a mixture or phase-specific k - ϵ turbulence model.

The predefined Phase Transport Mixture Model () multiphysics coupling couples a Laminar Flow or Turbulent Flow (RANS) interface to the Phase Transport interface, providing mass-averaged formulations of the selected mixture model interfaces that can handle an arbitrary number of dispersed phases.



The Nonisothermal Mixture Model () interfaces couple a Laminar Flow or Turbulent Flow (RANS) interface, a Phase Transport interface, and a Heat Transfer in Fluids interface using the three multiphysics coupling nodes:

Nonisothermal Flow () , Mixture Model () , and Nonisothermal Mixture Model () . They can be used for studies of boiling and cavitation.

The Two-Phase Flow, Level Set interfaces () , the Two-Phase Flow, Phase Field interfaces () , and the Two-Phase Flow, Moving Mesh interface () are used to model two fluids separated by a fluid–fluid interface. Each moving interface is tracked in detail using either the level set method, the phase field method, or by a moving mesh, respectively. The level set and phase field methods use a fixed mesh and solve additional equations to track the interface location. The moving mesh method solves the Navier–Stokes equations on a moving mesh with boundary conditions to represent the interface. In this case, equations must be solved for the mesh deformation. Since a surface in the geometry is used to represent the interface between the two fluids in the Moving Mesh interface, the interface itself cannot break up into multiple disconnected surfaces. This means that the Moving Mesh interface cannot be applied to problems such as droplet formation in inkjet devices. (In such applications, the level set or phase field in fluids interfaces are appropriate.) These two-phase flow interfaces support incompressible flows, where one or both fluids can be non-Newtonian. They also support turbulent flow. The Brinkman Equations multiphysics interface () is used to track the interface between two immiscible fluids in a porous medium.

The Two-Phase Thin-Film Flow, Phase Field interfaces () are multiphysics interfaces which couple a Thin-Film Flow interface to a Phase Field Thin-Film Flow interface to model two-phase flow in thin layers. Both of the coupled physics interfaces are boundary physics interfaces, which means that the boundary level is the highest level; they do not have a domain level.

The Laminar Three-Phase Flow, Phase Field interface () models laminar flow of three incompressible phases, which may be either Newtonian or non-Newtonian. The moving fluid–fluid interfaces between the three phases are tracked in detail using the phase-field method.

Under the Phase Transport branch, the Phase Transport interface () can be used to model transport of an arbitrary number of phases. The transport velocity must be obtained from one of the momentum transport interfaces (that is, from the single-phase or multiphase flow interfaces) or be specified manually. The Phase Transport in Porous Media interface () can be used to model transport of an arbitrary number of phases in a porous medium. The transport velocity is derived from an absolute pressure, which must be supplied. The Phase Transport in Free and Porous Media Flow interface () can be used to model transport of an arbitrary number of phases in coupled free and porous media flow. An absolute pressure must be supplied in the porous region and a velocity field must be supplied in the free-flow region. Both can be obtained from one of the momentum conservation interfaces or be specified manually.

POROUS MEDIA AND SUBSURFACE FLOW

The Brinkman Equations interface () models flow through porous media where the influence of shear stresses is significant. This physics interface supports the Stokes–Brinkman formulation, suitable for very low flow velocities, as well as the full Brinkman equations including convective terms and Forchheimer drag, which is used to account for effects at high interstitial velocities. The flow can be either incompressible or compressible, provided the Mach number is less than 0.3. Turbulent flow in porous media can be modeled using all RANS turbulence models except for the Spalart–Allmaras model.

The Darcy’s Law interface () models relatively slow flows through porous media for cases where the effects of shear stresses perpendicular to the flow are small.

The Multiphase Flow in Porous Media interface () can be used to model transport of an arbitrary number of phases in a porous medium where the velocity is obtained from Darcy’s law. This is a multiphysics interface for which the couplings between fluid flow and phase transport are set up automatically.

The Multiphase Free and Porous Media Flow interface () models the transport of multiple phases in coupled free and porous media flow. This multiphysics interface automatically couples the flow in the free and the porous domain, as well as the flow in both domains with the phase transport.

The Two-Phase Darcy’s Law interface () sets up two Darcy’s-law equations, one for each fluid phase in the porous medium. It couples the two, for example using a capillary expression. It is tailored to model effects such as moisture transport in porous media.

The Free and Porous Media Flow, Brinkman interface () models porous media containing open channels connected to the porous media, such as in fixed-bed reactors and catalytic converters. Turbulent flow can be modeled using all RANS turbulence models except for the Spalart–Allmaras model.

The Free and Porous Media Flow, Darcy interface () models porous media flow connected to free flow domains. This multiphysics interface couples the Laminar Flow interface with the Darcy’s Law interface over their common boundary.

The Thin-Film and Porous Media Flow interface () models flow in thin films adjacent to porous media domains. This multiphysics interface couples a Thin-Film Flow interface and a Darcy’s Law interface over their common boundary.

NONISOTHERMAL FLOW

The Nonisothermal Flow, Laminar Flow multiphysics interface () is primarily applied to model flow at low to intermediate Reynolds numbers in situations where the temperature and flow fields have to be coupled. A typical example is natural convection, where thermal buoyancy forces drive the flow. This is a multiphysics interface for which the nonlocal couplings between fluid flow and heat transfer are set up automatically.

The Nonisothermal Flow, Turbulent Flow multiphysics interfaces () solve the Reynolds-Averaged Navier–Stokes (RANS) equations coupled to heat transfer in fluids and in solids. There is support for all RANS turbulence models.

The Large Eddy Simulation (LES) multiphysics interfaces () couple one of the three LES interfaces to a Heat Transfer in Fluids interface. These interfaces are applicable to incompressible, weakly compressible, and compressible (Mach < 0.3) flows of Newtonian fluids.

Under the Rotating Machinery, Nonisothermal Flow branch, the Laminar Flow multiphysics interface () couples a Laminar Flow interface and a Heat Transfer in Fluids interface, and adds a Rotating Domain node under Moving Mesh. This multiphysics interface is applicable to fluid-flow problems where one or more of the boundaries rotate, for example in mixers and around propellers, and supports incompressible, weakly compressible, and compressible (Mach < 0.3) flows of Newtonian and non-Newtonian fluids.

The Brinkman Equations multiphysics interface () couples the Brinkman Equations interface to a Heat Transfer in Porous Media interface and automatically adds a Porous Material node under Materials in the model tree.

The Viscoelastic multiphysics interface () couples the Viscoelastic Flow interface to a Heat Transfer in Fluids interface.

The Conjugate Heat Transfer multiphysics interfaces () are also included with the CFD Module and are almost identical to the Nonisothermal Flow interfaces. They only differ in the default domain feature selected — Heat Transfer in Solids instead of Heat Transfer in Fluid.

HIGH MACH NUMBER FLOW

The High Mach Number Flow, Laminar interface () solves the continuity, momentum, and energy equations for fully compressible laminar flow. This physics interface is typically used to model low-pressure systems, for which the Mach number can be large but the flow remains laminar.

The High Mach Number Flow, Turbulent Flow interfaces () solve the continuity, momentum, and energy equations for the averaged flow variables in

fully compressible turbulent flow, which are coupled to transport equations for the turbulence quantities. All RANS turbulence models are available.

The Compressible Euler Equations interface () solves the equations for transient inviscid ideal gas flow where the velocity magnitude is comparable to the speed of sound — that is, compressible flows in the transonic and supersonic range.

The Rotating Machinery, High Mach Number Flow interfaces () combine the High Mach Number Flow interfaces and a Rotating Domain node under Moving Mesh, and are applicable to fluid-flow problems where one or more of the boundaries rotate, for example in turbines and around propellers. These physics interfaces support compressible, laminar, and turbulent flow using the k - ϵ model or the Spalart–Allmaras model.

FLUID-STRUCTURE INTERACTION

The Fluid-Structure Interaction interfaces () couple a Single-Phase Flow or Two-Phase Flow, Phase Field interface to a Solid Mechanics interface for studies of deformation induced by fluid forces.



THIN-FILM FLOW



The Thin-Film Flow interfaces () model the flow of liquids or gases confined in a thin layer on a surface. Applying equations defined on a surface, these physics interfaces compute the average velocity and pressure across the layer in narrow planar structures. The physics interfaces are thus boundary physics interfaces, which means that the boundary level is the highest level; they do not have a domain level. The simulation of the flow of a lubrication oil between two rotating cylinders is an example of a possible application for this physics interface.

SHALLOW WATER EQUATIONS



The Shallow Water Equations interface () models free-surface flows in 1D and 2D domains using a depth-averaged formulation. The interface is based on the discontinuous Galerkin method (dG-FEM) and uses a time-explicit solver.

REACTING FLOW





The Laminar Flow interface () and the Laminar Flow, Diluted Species interface () under the Reacting Flow branch (under the Chemical Species Transport branch) combine the functionality of the Single-Phase Flow and Transport of Concentrated Species interfaces or Transport of Diluted Species interface, respectively. These physics interfaces are primarily applied to model flow at low to intermediate Reynolds numbers in situations where the mass transport and flow fields have to be coupled.

The Turbulent Flow interfaces () and the Turbulent Flow, Diluted Species interfaces () under the Reacting Flow branch apply the Reynolds-Averaged Navier–Stokes (RANS) equations together with the functionality in the Transport of Concentrated Species interface or Transport of Diluted Species respectively. They model mass and momentum transport in turbulent reacting fluid flow. There are Model Wizard entries for the standard k - ϵ model, the k - ω model, the SST model, and the low Reynolds number k - ϵ model. A different turbulence model can be selected in the Settings window for the physics interface.

REACTING FLOW IN POROUS MEDIA

The Reacting Flow in Porous Media, Transport of Diluted Species interface () and the Reacting Flow in Porous Media, Transport of Concentrated Species interface () model diluted and concentrated reacting mixtures, respectively, transported by free and porous media flow. Effective diffusion coefficients in a porous matrix can be calculated from the porosity.



NONISOTHERMAL REACTING FLOW

The Brinkman Equations (), Laminar Flow (), Turbulent Flow () and Large Eddy Simulation () multiphysics interfaces combine the equations for fluid flow with mass transport in fluid mixtures, with optional chemistry and heat transfer. For turbulent flow, there are Model Wizard entries for the standard k - ϵ model, the k - ω model, the SST model, and the low Reynolds number k - ϵ model. A different turbulence model can be selected in the Settings window for the physics interface. For LES, all three models are supported. These interfaces require a license to the Battery Module or the Chemical Reaction Engineering Module or the Fuel Cell and Electrolyzer Module.

HIGH MACH NUMBER REACTING FLOW

The Laminar Flow, Diluted Species multiphysics interface () combines the functionality of the High Mach Number Flow, Laminar interface and the Transport of Diluted Species interface to simulate the transport of dilute species in gas flows where the velocity magnitude is comparable to the speed of sound in the gas, that is, flows in the transonic and supersonic range.

The Turbulent Flow, Diluted Species multiphysics interfaces () model transport of dilute species in turbulent gas flows in the transonic and supersonic range. There are two Model Wizard entries for the k - ϵ model and the Spalart–Allmaras model. A different turbulence model can be selected in the Settings window for the physics interface.

The Laminar Flow () and Turbulent Flow () interfaces combine the functionality of the High Mach Number Flow interfaces, the Transport of

Concentrated Species interface, and the Chemistry interface. These interfaces require a license to the Chemical Reaction Engineering Module.

DISPERSED TWO-PHASE FLOW WITH SPECIES TRANSPORT







The Laminar Flow interface () models dispersed two-phase flow with mass transfer. The interface combines Mixture Model, Laminar Flow with mass transport in both the continuous phase and the dispersed phase. The interface can for example be used to model liquid-liquid extraction.

The Turbulent Flow interfaces () model turbulent, dispersed two-phase flow with mass transfer, using either the standard $k-\epsilon$ model, the $k-\omega$ model, the SST model, or the low Reynolds number $k-\epsilon$ model.

















SOLID THIN-FILM DAMPING















The Solid Thin-Film Damping interface () models fluid-induced damping in solid structures. The interface combines a Solid Mechanics interface and a Thin-Film Flow interface using the Structure Thin-Film Flow Interaction multiphysics coupling node.

Physics Interface Guide by Space Dimension and Study Type







PHYSICS INTERFACE	ICON	TAG	SPACE DIMENSION	AVAILABLE STUDY TYPE
Imported Fluid Flow		iff	3D	mapping; transient mapping
 Chemical Species Transport				
Transport of Diluted Species ¹		tds	all dimensions	stationary; time dependent
Transport of Concentrated Species		tcs	all dimensions	stationary; time dependent
Transport of Diluted Species in Porous Media		tds	all dimensions	stationary; time dependent
Transport of Concentrated Species in Porous Media		tcs	all dimensions	stationary; time dependent















PHYSICS INTERFACE	ICON	TAG	SPACE DIMENSION	AVAILABLE STUDY TYPE
 Reacting Flow				
Laminar Flow, Diluted Species ¹		—	3D, 2D, 2D axisymmetric	stationary; time dependent
Laminar Flow, Concentrated Species		—	3D, 2D, 2D axisymmetric	stationary; time dependent
 Turbulent Flow, Diluted Species				
Turbulent Flow, k-ε		—	3D, 2D, 2D axisymmetric	stationary; time dependent
Turbulent Flow, k-ω		—	3D, 2D, 2D axisymmetric	stationary; time dependent
Turbulent Flow, SST		—	3D, 2D, 2D axisymmetric	stationary with initialization; time dependent with initialization
Turbulent Flow, Low Re k-ε		—	3D, 2D, 2D axisymmetric	stationary with initialization; time dependent with initialization
 Turbulent Flow, Concentrated Species				
Turbulent Flow, k-ε		—	3D, 2D, 2D axisymmetric	stationary; time dependent
Turbulent Flow, k-ω		—	3D, 2D, 2D axisymmetric	stationary; time dependent
Turbulent Flow, SST		—	3D, 2D, 2D axisymmetric	stationary with initialization; time dependent with initialization
Turbulent Flow, Low Re k-ε		—	3D, 2D, 2D axisymmetric	stationary with initialization; time dependent with initialization
 Reacting Flow in Porous Media				
Transport of Diluted Species		—	3D, 2D, 2D axisymmetric	stationary; time dependent















PHYSICS INTERFACE	ICON	TAG	SPACE DIMENSION	AVAILABLE STUDY TYPE
Transport of Concentrated Species		—	3D, 2D, 2D axisymmetric	stationary; time dependent
 Nonisothermal Reacting Flow				
Brinkman Equations ⁽⁴⁾		—	3D, 2D, 2D axisymmetric	stationary; time dependent
Laminar Flow ⁽⁴⁾		—	3D, 2D, 2D axisymmetric	stationary; time dependent
 Turbulent Flow⁽⁴⁾				
Turbulent Flow, $k-\epsilon$ ⁽⁴⁾		—	3D, 2D, 2D axisymmetric	stationary; time dependent
Turbulent Flow, $k-\omega$ ⁽⁴⁾		—	3D, 2D, 2D axisymmetric	stationary; time dependent
Turbulent Flow, SST ⁽⁴⁾		—	3D, 2D, 2D axisymmetric	stationary with initialization; time dependent with initialization
Turbulent Flow, Low Re $k-\epsilon$ ⁽⁴⁾		—	3D, 2D, 2D axisymmetric	stationary with initialization; time dependent with initialization
 Large Eddy Simulation⁽⁴⁾				
LES RBVM ⁽⁴⁾		—	3D	time dependent
LES RBVMWV ⁽⁴⁾		—	3D	time dependent
LES Smagorinsky ⁽⁴⁾		—	3D	time dependent
 High Mach Number Reacting Flow				
Laminar Flow ⁽³⁾		—	3D, 2D, 2D axisymmetric	stationary; time dependent
Laminar Flow, Diluted Species		—	3D, 2D, 2D axisymmetric	stationary; time dependent

PHYSICS INTERFACE	ICON	TAG	SPACE DIMENSION	AVAILABLE STUDY TYPE
 Turbulent Flow⁽³⁾				
Turbulent Flow, k- ϵ ⁽³⁾		—	3D, 2D, 2D axisymmetric	stationary; time dependent
Turbulent Flow, Spalart–Allmaras ⁽³⁾		spf	3D, 2D, 2D axisymmetric	stationary with initialization; time dependent with initialization
 Turbulent Flow, Diluted Species				
Turbulent Flow, k- ϵ		—	3D, 2D, 2D axisymmetric	stationary; time dependent
Turbulent Flow, Spalart–Allmaras		spf	3D, 2D, 2D axisymmetric	stationary with initialization; time dependent with initialization
 Dispersed Two-Phase Flow with Species Transport				
Laminar Flow		—	3D, 2D,	stationary; time dependent
 Turbulent Flow				
Turbulent Flow, k- ϵ		—	3D, 2D	stationary; time dependent
Turbulent Flow, k- ω		—	3D, 2D	stationary; time dependent
Turbulent Flow, SST		—	3D, 2D	stationary with initialization; time dependent with initialization
Turbulent Flow, Low Re k- ϵ		—	3D, 2D	stationary with initialization; time dependent with initialization
 Vapor–Liquid Equilibrium				
Laminar Vapor Flow ⁽³⁾		—	3D, 2D, 2D axisymmetric	stationary; time dependent

PHYSICS INTERFACE	ICON	TAG	SPACE DIMENSION	AVAILABLE STUDY TYPE
Laminar Two-Phase Flow ⁽³⁾		—	3D, 2D, 2D axisymmetric	stationary; time dependent
Turbulent Vapor Flow				
Turbulent Flow, $k-\epsilon$ ⁽³⁾		—	3D, 2D, 2D axisymmetric	stationary; time dependent
Turbulent Flow, $k-\omega$ ⁽³⁾		—	3D, 2D, 2D axisymmetric	stationary with initialization; time dependent with initialization
Turbulent Flow, SST ⁽³⁾		—	3D, 2D, 2D axisymmetric	stationary with initialization; time dependent with initialization
Turbulent Flow, Low Re $k-\epsilon$ ⁽³⁾		—	3D, 2D, 2D axisymmetric	stationary with initialization; time dependent with initialization
Fluid Flow				
Single-Phase Flow				
Creeping Flow		spf	3D, 2D, 2D axisymmetric	stationary; time dependent
Laminar Flow ^l		spf	3D, 2D, 2D axisymmetric	stationary; time dependent
Viscoelastic Flow		vef	3D, 2D, 2D axisymmetric	stationary; time dependent
Turbulent Flow				
Turbulent Flow, Algebraic γ Plus		spf	3D, 2D, 2D axisymmetric	stationary with initialization; time dependent with initialization
Turbulent Flow, L-VEL		spf	3D, 2D, 2D axisymmetric	stationary with initialization; time dependent with initialization
Turbulent Flow, $k-\epsilon$		spf	3D, 2D, 2D axisymmetric	stationary; time dependent

PHYSICS INTERFACE	ICON	TAG	SPACE DIMENSION	AVAILABLE STUDY TYPE
Turbulent Flow, Realizable k- ϵ		spf	3D, 2D, 2D axisymmetric	stationary; time dependent
Turbulent Flow, k- ω		spf	3D, 2D, 2D axisymmetric	stationary; time dependent
Turbulent Flow, SST		spf	3D, 2D, 2D axisymmetric	stationary with initialization; time dependent with initialization
Turbulent Flow, Low Re k- ϵ		spf	3D, 2D, 2D axisymmetric	stationary with initialization; time dependent with initialization
Turbulent Flow, Spalart-Allmaras		spf	3D, 2D, 2D axisymmetric	stationary with initialization; time dependent with initialization
Turbulent Flow, v2-f		spf	3D, 2D, 2D axisymmetric	stationary with initialization; time dependent with initialization
Turbulent Flow, Wilcox R- ω		spf	3D, 2D, 2D axisymmetric	stationary with initialization; time dependent with initialization
Turbulent Flow, SSG-LRR		spf	3D, 2D, 2D axisymmetric	stationary with initialization; time dependent with initialization
Turbulent Flow, Elliptic Blending R- ϵ		spf	3D, 2D, 2D axisymmetric	stationary with initialization; time dependent with initialization
 Large Eddy Simulation				
LES RBVM		spf	3D	time dependent
LES RBVMWV		spf	3D	time dependent
LES Smagorinsky		spf	3D	time dependent
 Detached Eddy Simulation				
DES RBVM, Spalart-Allmaras		spf	3D	time dependent

















PHYSICS INTERFACE	ICON	TAG	SPACE DIMENSION	AVAILABLE STUDY TYPE
DES RBVMWV, Spalart–Allmaras		spf	3D	time dependent
DES Smagorinsky, Spalart–Allmaras		spf	3D	time dependent
 Rotating Machinery, Fluid Flow				
Rotating Machinery, Laminar Flow		spf	3D, 2D	frozen rotor; time dependent
Rotating Machinery, Turbulent Flow, Algebraic γ Plus		spf	3D, 2D	frozen rotor with initialization; time dependent with initialization
Rotating Machinery, Turbulent Flow, L-VEL		spf	3D, 2D	frozen rotor with initialization; time dependent with initialization
Rotating Machinery, Turbulent Flow, k- ϵ		spf	3D, 2D	frozen rotor; time dependent
 Potential Flow				
Incompressible Potential Flow		ipf	3D, 2D, 2D axisymmetric	stationary
Compressible Potential Flow		cpf	all dimensions	stationary; time dependent
 Multiphase Flow				
 Bubbly Flow				
Laminar Bubbly Flow		bf	3D, 2D, 2D axisymmetric	stationary; time dependent
 Bubbly Flow, Turbulent Flow				
Bubbly Flow, Algebraic γ Plus		bf	3D, 2D, 2D axisymmetric	stationary with initialization; time dependent with initialization















PHYSICS INTERFACE	ICON	TAG	SPACE DIMENSION	AVAILABLE STUDY TYPE
Bubbly Flow, L-VEL		bf	3D, 2D, 2D axisymmetric	stationary with initialization; time dependent with initialization
Bubbly Flow, k-ε		bf	3D, 2D, 2D axisymmetric	stationary; time dependent
Bubbly Flow, Realizable k-ε		bf	3D, 2D, 2D axisymmetric	stationary; time dependent
Bubbly Flow, k-ω		bf	3D, 2D, 2D axisymmetric	stationary; time dependent
Bubbly Flow, SST		bf	3D, 2D, 2D axisymmetric	stationary with initialization; time dependent with initialization
Bubbly Flow, Low Re k-ε		bf	3D, 2D, 2D axisymmetric	stationary with initialization; time dependent with initialization
Bubbly Flow, Spalart-Allmaras		bf	3D, 2D, 2D axisymmetric	stationary with initialization; time dependent with initialization
Bubbly Flow, ν2-f		bf	3D, 2D, 2D axisymmetric	stationary with initialization; time dependent with initialization
 Mixture Model				
Mixture Model, Laminar Flow		mm	3D, 2D, 2D axisymmetric	stationary; time dependent
 Mixture Model, Turbulent Flow				
Mixture Model, Algebraic yPlus		mm	3D, 2D, 2D axisymmetric	stationary with initialization; time dependent with initialization
Mixture Model, L-VEL		mm	3D, 2D, 2D axisymmetric	stationary with initialization; time dependent with initialization
Mixture Model, k-ε		mm	3D, 2D, 2D axisymmetric	stationary; time dependent
Mixture Model, Realizable k-ε		mm	3D, 2D, 2D axisymmetric	stationary; time dependent









PHYSICS INTERFACE	ICON	TAG	SPACE DIMENSION	AVAILABLE STUDY TYPE
Mixture Model, k- ω		mm	3D, 2D, 2D axisymmetric	stationary; time dependent
Mixture Model, SST		mm	3D, 2D, 2D axisymmetric	stationary with initialization; time dependent with initialization
Mixture Model, Low Re k- ϵ		mm	3D, 2D, 2D axisymmetric	stationary with initialization; time dependent with initialization
Mixture Model, Spalart-Allmaras		mm	3D, 2D, 2D axisymmetric	stationary with initialization; time dependent with initialization
Mixture Model, v2-f		mm	3D, 2D, 2D axisymmetric	stationary with initialization; time dependent with initialization
Euler-Euler Model				
Euler-Euler Model, Laminar Flow		ee	3D, 2D, 2D axisymmetric	stationary; time dependent
Euler-Euler Model, Turbulent Flow		ee	3D, 2D, 2D axisymmetric	stationary; time dependent
Phase Transport Mixture Model				
Phase Transport, Mixture Model, Laminar Flow		—	3D, 2D, 2D axisymmetric	stationary; time dependent
Phase Transport, Mixture Model, Algebraic γ Plus		—	3D, 2D, 2D axisymmetric	stationary with initialization; time dependent with initialization
Phase Transport, Mixture Model, L-VEL		—	3D, 2D, 2D axisymmetric	stationary with initialization; time dependent with initialization
Phase Transport, Mixture Model, k- ϵ		—	3D, 2D, 2D axisymmetric	stationary; time dependent
Phase Transport, Mixture Model, Realizable k- ϵ		—	3D, 2D, 2D axisymmetric	stationary; time dependent













PHYSICS INTERFACE	ICON	TAG	SPACE DIMENSION	AVAILABLE STUDY TYPE
Phase Transport, Mixture Model, k- ω		—	3D, 2D, 2D axisymmetric	stationary; time dependent
Phase Transport, Mixture Model, SST		—	3D, 2D, 2D axisymmetric	stationary with initialization; time dependent with initialization
Phase Transport, Mixture Model, Low Re k- ϵ		—	3D, 2D, 2D axisymmetric	stationary with initialization; time dependent with initialization
Phase Transport, Mixture Model, Spalart-Allmaras		—	3D, 2D, 2D axisymmetric	stationary with initialization; time dependent with initialization
Phase Transport, Mixture Model, v2-f		—	3D, 2D, 2D axisymmetric	stationary with initialization; time dependent with initialization
Nonisothermal Mixture Model				
Nonisothermal Mixture Model, Laminar Flow		—	3D, 2D, 2D axisymmetric	stationary; time dependent
Nonisothermal Mixture Model, Algebraic yPlus		—	3D, 2D, 2D axisymmetric	stationary with initialization; time dependent with initialization
Nonisothermal Mixture Model, L-VEL		—	3D, 2D, 2D axisymmetric	stationary with initialization; time dependent with initialization
Nonisothermal Mixture Model, k- ϵ		—	3D, 2D, 2D axisymmetric	stationary; time dependent
Nonisothermal Mixture Model, Realizable k- ϵ		—	3D, 2D, 2D axisymmetric	stationary; time dependent
Nonisothermal Mixture Model, k- ω		—	3D, 2D, 2D axisymmetric	stationary; time dependent
Nonisothermal Mixture Model, SST		—	3D, 2D, 2D axisymmetric	stationary with initialization; time dependent with initialization
Nonisothermal Mixture Model, Low Re k- ϵ		—	3D, 2D, 2D axisymmetric	stationary with initialization; time dependent with initialization















PHYSICS INTERFACE	ICON	TAG	SPACE DIMENSION	AVAILABLE STUDY TYPE
Nonisothermal Mixture Model, Spalart–Allmaras		—	3D, 2D, 2D axisymmetric	stationary with initialization; time dependent with initialization
Nonisothermal Mixture Model, v2-f		—	3D, 2D, 2D axisymmetric	stationary with initialization; time dependent with initialization
 Two-Phase Flow, Moving Mesh				
Laminar Two-Phase Flow, Moving Mesh		—	3D, 2D, 2D axisymmetric	time dependent
 Two-Phase Flow, Level Set				
Laminar Two-Phase Flow, Level Set		—	3D, 2D, 2D axisymmetric	time dependent with phase initialization
Two-Phase Flow, Level Set, Algebraic γ Plus		—	3D, 2D, 2D axisymmetric	time dependent with initialization
Two-Phase Flow, Level Set, L-VEL		—	3D, 2D, 2D axisymmetric	time dependent with initialization
Two-Phase Flow, Level Set, k- ϵ		—	3D, 2D, 2D axisymmetric	time dependent with phase initialization
Two-Phase Flow, Level Set, Realizable k- ϵ		—	3D, 2D, 2D axisymmetric	time dependent with phase initialization
Two-Phase Flow, Level Set, k- ω		—	3D, 2D, 2D axisymmetric	time dependent with phase initialization
Two-Phase Flow, Level Set, SST		—	3D, 2D, 2D axisymmetric	time dependent with initialization
Two-Phase Flow, Level Set, Low Re k- ϵ		—	3D, 2D, 2D axisymmetric	time dependent with initialization
Two-Phase Flow, Level Set, Spalart–Allmaras		—	3D, 2D, 2D axisymmetric	time dependent with initialization
Two-Phase Flow, Level Set, v2-f		—	3D, 2D, 2D axisymmetric	time dependent with initialization















PHYSICS INTERFACE	ICON	TAG	SPACE DIMENSION	AVAILABLE STUDY TYPE
 Two-Phase Flow, Phase Field				
Laminar Two-Phase Flow, Phase Field		—	3D, 2D, 2D axisymmetric	time dependent with phase initialization
Two-Phase Flow, Phase Field, Algebraic γ Plus		—	3D, 2D, 2D axisymmetric	time dependent with initialization
Two-Phase Flow, Phase Field, L-VEL		—	3D, 2D, 2D axisymmetric	time dependent with initialization
Two-Phase Flow, Phase Field, k- ϵ		—	3D, 2D, 2D axisymmetric	time dependent with phase initialization
Two-Phase Flow, Phase Field, Realizable k- ϵ		—	3D, 2D, 2D axisymmetric	time dependent with phase initialization
Two-Phase Flow, Phase Field, k- ω		—	3D, 2D, 2D axisymmetric	time dependent with phase initialization
Two-Phase Flow, Phase Field, SST		—	3D, 2D, 2D axisymmetric	time dependent with initialization
Two-Phase Flow, Phase Field, Low Re k- ϵ		—	3D, 2D, 2D axisymmetric	time dependent with initialization
Two-Phase Flow, Phase Field, Spalart–Allmaras		—	3D, 2D, 2D axisymmetric	time dependent with initialization
Two-Phase Flow, Phase Field, ν_2 -f		—	3D, 2D, 2D axisymmetric	time dependent with initialization
 Two-Phase Thin-Film Flow, Phase Field				
Two-Phase Thin-Film Flow, Phase Field		—	3D, 2D, 2D axisymmetric	time dependent with phase initialization
 Three-Phase Flow, Phase Field				
Laminar, Three-Phase Flow, Phase Field		—	3D, 2D, 2D axisymmetric	time dependent with phase initialization
 Phase Transport				
Phase Transport		phtr	all dimensions	stationary; time dependent









PHYSICS INTERFACE	ICON	TAG	SPACE DIMENSION	AVAILABLE STUDY TYPE
Phase Transport in Porous Media		phtr	all dimensions	stationary; time dependent
Phase Transport in Free and Porous Media Flow		phtr	all dimensions	stationary; time dependent
 Porous Media and Subsurface Flow				
Brinkman Equations		br	3D, 2D, 2D axisymmetric	stationary; time dependent
Darcy's Law		dl	all dimensions	stationary; time dependent
Multiphase Flow in Porous Media		—	all dimensions	stationary; time dependent
Multiphase Free and Porous Media Flow		—	3D, 2D, 2D axisymmetric	stationary; time dependent
Two-Phase Darcy's Law		tpdl	3D, 2D, 2D axisymmetric	stationary; time dependent
Free and Porous Media Flow, Brinkman		fp	3D, 2D, 2D axisymmetric	stationary; time dependent
Free and Porous Media Flow, Darcy		—	3D, 2D, 2D axisymmetric	stationary; time dependent
Thin-Film and Porous Media Flow		—	3D, 2D, 2D axisymmetric	stationary; time dependent; frequency domain
 Nonisothermal Flow				
Laminar Flow ^(1,2)		—	3D, 2D, 2D axisymmetric	stationary; time dependent; Stationary, one-way NITF; time dependent, one-way NITF
Brinkman Equations		—	3D, 2D, 2D axisymmetric	stationary; time dependent; stationary, one-way NITF; time dependent, one-way NITF
Viscoelastic Flow		—	3D, 2D, 2D axisymmetric	stationary; time dependent; stationary, one-way NITF; time dependent, one-way NITF



PHYSICS INTERFACE	ICON	TAG	SPACE DIMENSION	AVAILABLE STUDY TYPE
 Turbulent Flow				
Turbulent Flow, Algebraic γ Plus ⁽²⁾		—	3D, 2D, 2D axisymmetric	stationary with initialization; time dependent with initialization; Stationary, one-way NITF; time dependent, one-way NITF
Turbulent Flow, L-VEL ⁽²⁾		—	3D, 2D, 2D axisymmetric	stationary with initialization; time dependent with initialization; Stationary, one-way NITF; time dependent, one-way NITF
Turbulent Flow, k - ϵ ⁽²⁾		—	3D, 2D, 2D axisymmetric	stationary; time dependent; Stationary, one-way NITF; time dependent, one-way NITF
Turbulent Flow, Realizable k - ϵ ⁽²⁾		—	3D, 2D, 2D axisymmetric	stationary; time dependent; Stationary, one-way NITF; time dependent, one-way NITF
Turbulent Flow, k - ω ⁽²⁾		—	3D, 2D, 2D axisymmetric	stationary; time dependent; Stationary, one-way NITF; time dependent, one-way NITF
Turbulent Flow, SST ⁽²⁾		—	3D, 2D, 2D axisymmetric	stationary with initialization; time dependent with initialization; Stationary, one-way NITF; time dependent, one-way NITF
Turbulent Flow, Low Re k - ϵ ⁽²⁾		—	3D, 2D, 2D axisymmetric	stationary with initialization; time dependent with initialization; Stationary, one-way NITF; time dependent, one-way NITF
Turbulent Flow, Spalart-Allmaras ⁽²⁾		—	3D, 2D, 2D axisymmetric	stationary with initialization; time dependent with initialization; Stationary, one-way NITF; time dependent, one-way NITF

PHYSICS INTERFACE	ICON	TAG	SPACE DIMENSION	AVAILABLE STUDY TYPE
Turbulent Flow, $v_2-f^{(2)}$		—	3D, 2D, 2D axisymmetric	stationary with initialization; time dependent with initialization; Stationary, one-way NITF; time dependent, one-way NITF
Turbulent Flow, Wilcox $R-\omega^{(2)}$		—	3D, 2D, 2D axisymmetric	stationary; time dependent; Stationary, one-way NITF; time dependent, one-way NITF
Turbulent Flow, SSG-LRR ⁽²⁾		—	3D, 2D, 2D axisymmetric	stationary; time dependent; Stationary, one-way NITF; time dependent, one-way NITF
Turbulent Flow, Elliptic Blending $R-\epsilon^{(2)}$		—	3D, 2D, 2D axisymmetric	stationary; time dependent; Stationary, one-way NITF; time dependent, one-way NITF
 Large Eddy Simulation				
LES RBVM		—	3D	time dependent
LES RBVMWV		—	3D	time dependent
LES Smagorinsky		—	3D	time dependent
 Rotating Machinery, Nonisothermal Flow				
Laminar Flow		—	3D, 2D	frozen rotor; time dependent
 High Mach Number Flow				
High Mach Number Flow, Laminar		hmnf	3D, 2D, 2D axisymmetric	stationary; time dependent
High Mach Number Flow, Algebraic γ Plus		hmnf	3D, 2D, 2D axisymmetric	stationary with initialization; time dependent with initialization

PHYSICS INTERFACE	ICON	TAG	SPACE DIMENSION	AVAILABLE STUDY TYPE
High Mach Number Flow, L-VEL		hmnf	3D, 2D, 2D axisymmetric	stationary with initialization; time dependent with initialization
High Mach Number Flow, Spalart-Allmaras		hmnf	3D, 2D, 2D axisymmetric	stationary with initialization; time dependent with initialization
High Mach Number Flow, k-ε		hmnf	3D, 2D, 2D axisymmetric	stationary; time dependent
High Mach Number Flow, Realizable k-ε		hmnf	3D, 2D, 2D axisymmetric	stationary; time dependent
High Mach Number Flow, k-ω		hmnf	3D, 2D, 2D axisymmetric	stationary; time dependent
High Mach Number Flow, SST		hmnf	3D, 2D, 2D axisymmetric	stationary with initialization; time dependent with initialization
High Mach Number Flow, Low Reynolds Number k-ε		hmnf	3D, 2D, 2D axisymmetric	stationary with initialization; time dependent with initialization
High Mach Number Flow, v2-f		hmnf	3D, 2D, 2D axisymmetric	stationary with initialization; time dependent with initialization
High Mach Number Flow, Wilcox R-ω		hmnf	3D, 2D, 2D axisymmetric	stationary with initialization; time dependent with initialization
High Mach Number Flow, SSG-LRR		hmnf	3D, 2D, 2D axisymmetric	stationary with initialization; time dependent with initialization
High Mach Number Flow, Elliptic Blending R-ε		hmnf	3D, 2D, 2D axisymmetric	stationary with initialization; time dependent with initialization
Compressible Euler Equations		cee	3D, 2D	time dependent
 Rotating Machinery, High Mach Number Flow				
High Mach Number Flow, Laminar		—	3D, 2D	frozen rotor; time dependent

PHYSICS INTERFACE	ICON	TAG	SPACE DIMENSION	AVAILABLE STUDY TYPE
High Mach Number Flow, $k-\epsilon$		—	3D, 2D	frozen rotor; time dependent
High Mach Number Flow, Spalart–Allmaras		—	3D, 2D	frozen rotor with initialization; time dependent with initialization
 Fluid–Structure Interaction				
Fluid–Solid Interaction, Fixed Geometry ²		—	3D, 2D, 2D axisymmetric	stationary; stationary, one way; time dependent; time dependent, one way
Fluid–Solid Interaction, Two-Phase Flow, Phase Field, Fixed Geometry ²		—	3D, 2D, 2D axisymmetric	time dependent; time dependent with phase initialization
Solid–Thin-Film Damping ²		—	3D, 2D, 2D axisymmetric	stationary; eigenfrequency; time dependent; t frequency domain;
 Thin-Film Flow				
Thin–Film Flow		tff	3D, 2D, 2D axisymmetric	stationary; time dependent; frequency domain; eigenfrequency
Thin–Film Flow, Domain		tff	2D	stationary; time dependent; frequency domain; eigenfrequency
 Shallow Water Equations				
Shallow Water Equations, Time Explicit		swe	1D and 2D	time dependent
 Heat Transfer				
Heat Transfer in Fluids ¹		ht	all dimensions	stationary; time dependent
Heat Transfer in Solids and Fluids ¹		ht	all dimensions	stationary; time dependent
 Conjugate Heat Transfer				





PHYSICS INTERFACE	ICON	TAG	SPACE DIMENSION	AVAILABLE STUDY TYPE
Laminar Flow ^(1,2)		—	3D, 2D, 2D axisymmetric	stationary; time dependent; Stationary, one-way NITF; time dependent, one-way NITF
 Turbulent Flow				
Turbulent Flow, Algebraic γ Plus ⁽²⁾		—	3D, 2D, 2D axisymmetric	stationary with initialization; time dependent with initialization; Stationary, one-way NITF; time dependent, one-way NITF
Turbulent Flow, L-VEL ⁽²⁾		—	3D, 2D, 2D axisymmetric	stationary with initialization; time dependent with initialization; Stationary, one-way NITF; time dependent, one-way NITF
Turbulent Flow, $k-\epsilon$ ⁽²⁾		—	3D, 2D, 2D axisymmetric	stationary; time dependent; Stationary, one-way NITF; time dependent, one-way NITF
Turbulent Flow, Realizable $k-\epsilon$ ⁽²⁾		—	3D, 2D, 2D axisymmetric	stationary; time dependent; Stationary, one-way NITF; time dependent, one-way NITF
Turbulent Flow, $k-\omega$ ⁽²⁾		—	3D, 2D, 2D axisymmetric	stationary; time dependent; Stationary, one-way NITF; time dependent, one-way NITF
Turbulent Flow, SST ⁽²⁾		—	3D, 2D, 2D axisymmetric	stationary with initialization; time dependent with initialization; Stationary, one-way NITF; time dependent, one-way NITF
Turbulent Flow, Low Re $k-\epsilon$ ⁽²⁾		—	3D, 2D, 2D axisymmetric	stationary with initialization; time dependent with initialization; Stationary, one-way NITF; time dependent, one-way NITF

PHYSICS INTERFACE	ICON	TAG	SPACE DIMENSION	AVAILABLE STUDY TYPE
Turbulent Flow, Spalart–Allmaras ⁽²⁾		—	3D, 2D, 2D axisymmetric	stationary with initialization; time dependent with initialization; Stationary, one-way NITF; time dependent, one-way NITF
Turbulent Flow, v2-f ⁽²⁾		—	3D, 2D, 2D axisymmetric	stationary with initialization; time dependent with initialization; Stationary, one-way NITF; time dependent, one-way NITF
Heat Transfer in Porous Media		ht	all dimensions	stationary; time dependent

 **Structural Mechanics**

 **Mathematics**

 **Moving Interface**

Level Set		ls	all dimensions	time dependent with phase initialization
Level Set in Porous Media		ls	all dimensions	time dependent with phase initialization
Phase Field in Fluids		pf	all dimensions	time dependent; time dependent with phase initialization
Phase Field Thin-Film Flow		ptff	3D, 2D, 2D axisymmetric	time dependent with phase initialization
Ternary Phase Field		terpf	3D, 2D, 2D axisymmetric	time dependent

¹ This physics interface is included with the core COMSOL package but has added functionality for this module.

² This physics interface is a predefined multiphysics coupling that automatically adds all the physics interfaces and coupling features required.

³ Requires the addition of the Chemical Reaction Engineering Module.

⁴ Requires the addition of the Battery Module or the Chemical Reaction Engineering Module or the Fuel Cell and Electrolyzer Module

Tutorial Model — Backstep

This tutorial solves the incompressible Navier–Stokes equations in a backstep geometry. A characteristic feature of fluid flow in geometries of this kind is the recirculation region that forms where the flow exits the narrow inlet region. The application demonstrates the modeling procedure for laminar flows in the CFD Module.

Model Geometry

The model consists of a pipe connected to a block-shaped duct (see Figure 7). Due to symmetry, it is sufficient to model one eighth of the full geometry.

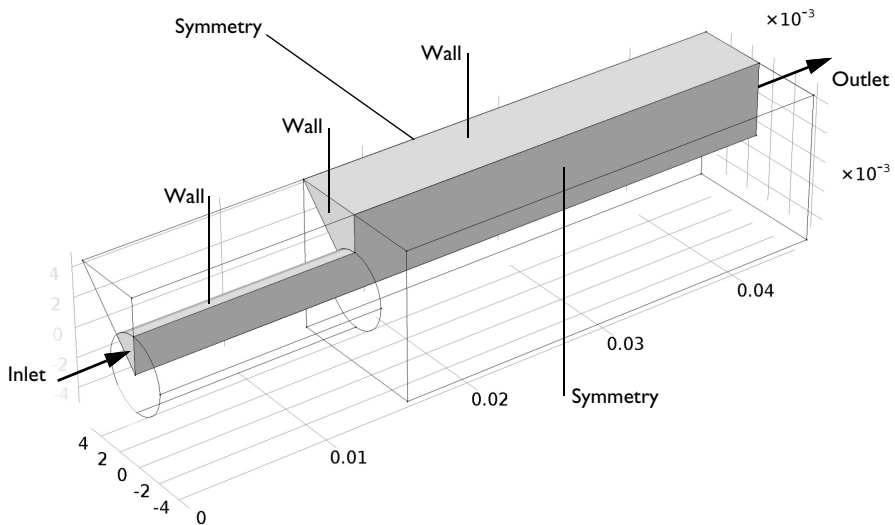

Figure 7: The model geometry showing the symmetry.

Domain Equations and Boundary Conditions

The flow in this model is laminar and you should therefore use the Laminar Flow interface.

The inlet flow is fully developed, which will be specified by the corresponding inlet boundary condition. This boundary condition computes the flow profile for fully developed flow in a channel of arbitrary cross section. The boundary condition at the outlet sets a constant relative pressure. Furthermore, the vertical and inclined

boundaries along the length of the geometry are symmetry boundaries. All other boundaries are solid walls described by a no-slip boundary condition.

Results

Figure 8 shows a combined surface and arrow plot of the flow velocity. This plot does not reveal the recirculation region in the duct immediately beyond the inlet pipe's end. For this purpose, a streamline plot is more useful, as shown in Figure 9.

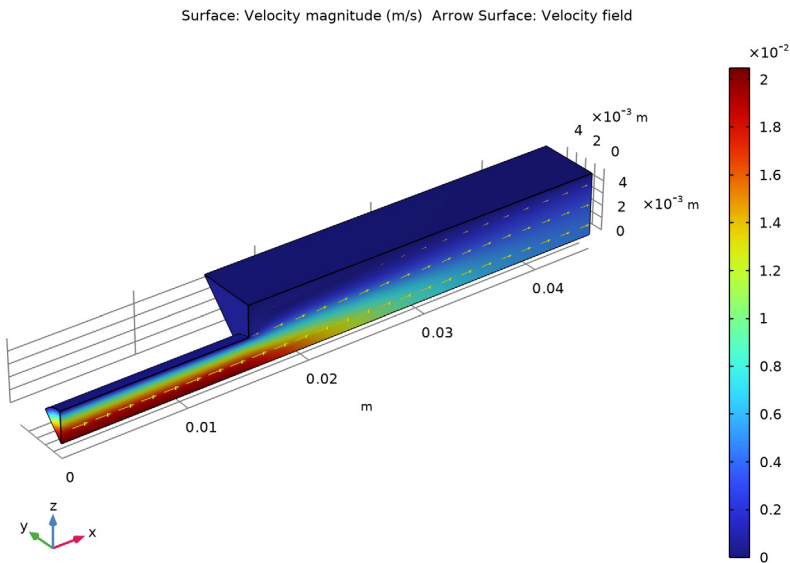

Figure 8: The velocity field in the backstep geometry.

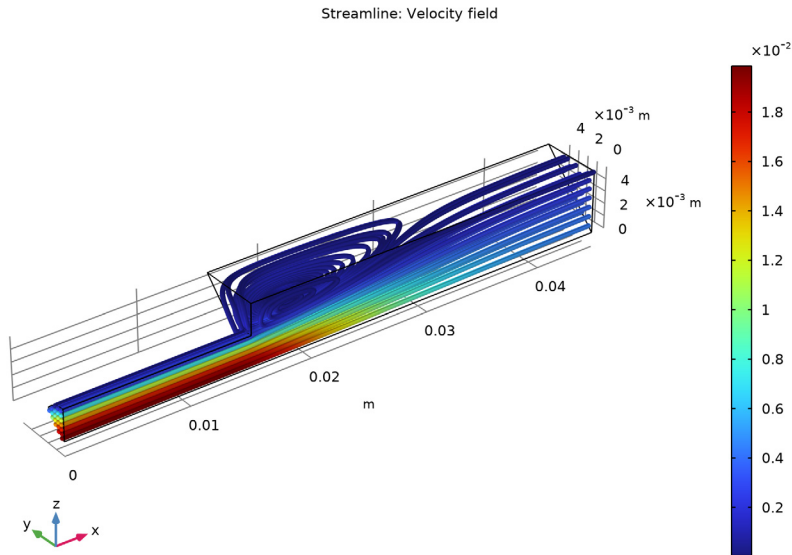

Figure 9: The recirculation region visualized using a velocity streamline plot.

The following instructions show how to set up the model, solve it, and reproduce these plots.



Model Wizard

The first step to build an application is to open the COMSOL Desktop, then select the physics interface and specify the type of analysis you want to do — in this case, a stationary, Laminar Flow analysis.





Note: These instructions are for the user interface on Windows but also apply, with minor differences, to Linux and Mac.

- I To open the software, double-click the COMSOL icon on the desktop. When the software opens, you can choose to use the Model Wizard to create a new COMSOL Multiphysics application or Blank Model to create one manually. For this tutorial, click the Model Wizard button.

The Model Wizard guides you through the first steps of setting up an application. If the COMSOL Desktop is already open, you can start the Model



Wizard by selecting New  from the File menu and then clicking Model Wizard .

The next window lets you select the dimension of the modeling space.

- 2 In the Select Space Dimension window click the 3D button .
- 3 In the Select Physics tree under Fluid Flow > Single-Phase Flow click Laminar Flow (spf) .
- 4 Click Add and then click the Study button .
- 5 In the tree under General Studies, click Stationary .
- 6 Click the Done button .

Global Definitions — Parameters

The first task is to define a parameter for the inlet velocity.

- 1 In the Home toolbar click Parameters  and select Parameter 1 .

Note: On Linux and Mac, the Home toolbar refers to the specific set of controls near the top of the Desktop.

2 In the Settings window for Parameters locate the Parameters section. In the table enter the following settings:

- In the Name text field, enter v0.
- In the Expression text field, enter 1[cm/s].
- In the Description text field, enter Inlet velocity.

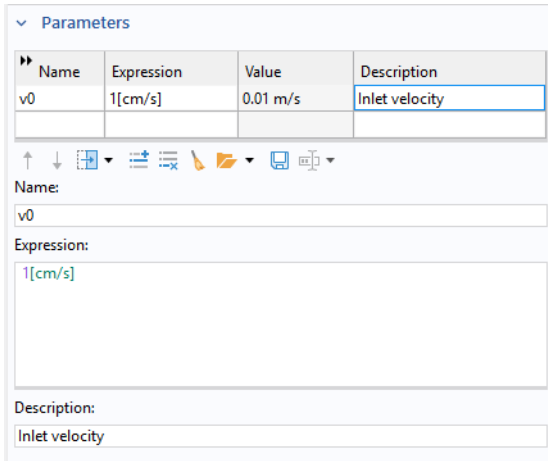



Geometry I

You can build the backstep geometry from geometric primitives. Here, instead use a file containing the parameterized sequence of geometry features that has been provided for convenience.



Note: The location of the file used in this exercise varies based on your installation. For example, if the installation is on your hard drive, the file path might be similar to

C:\Program Files\COMSOL\COMSOL64\Multiphysics\applications\.

- 1 In the Geometry toolbar choose Insert Sequence .
- 2 Browse to the application library folder and double-click the file `\CFD_Module\Single-Phase_Flow\backstep_geom_sequence.mph`.
- 3 Go to the Home toolbar and click Build All .

The geometry sequence is now inserted into your component and should look like the geometry in [Figure 7](#).

Materials

- 1 In the Home toolbar click Add Material .
- 2 Go to the Add Material window. In the tree under Built-In click Water, liquid.
- 3 In the Add Material window, click  Add to Component.
- 4 In the Home toolbar click Add Material  again to close the window.

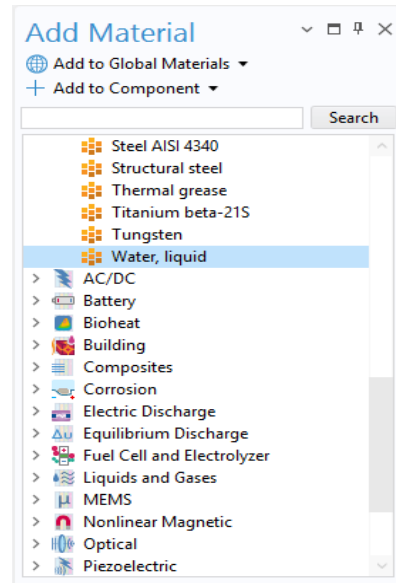

The physical properties are now available for the CFD simulation. The next step is to specify the domain and boundary conditions.



Laminar Flow



The Fluid Properties 1 node specifies the domain equations and by default uses the material properties specified by the Water, liquid material selected in the previous steps.

Inlet 1

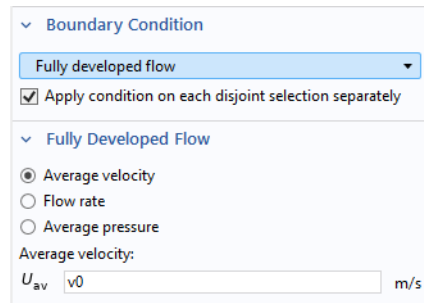
- 1 In the Physics toolbar click Boundaries  and choose Inlet .
- 2 Select Boundary 1, which represents the inlet.
- 3 Under Boundary Condition from the Boundary condition list, select Fully developed flow.
- 4 Locate the Fully Developed Flow section. In the U_{av} text field, type $v0$ (which you defined as a Global Parameter).



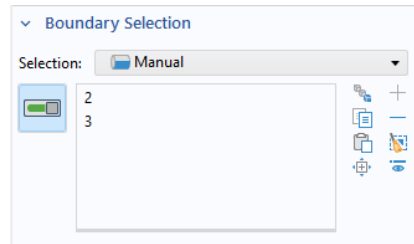

Symmetry 1

- 1 In the Physics toolbar click Boundaries  and choose Symmetry .
- 2 Select Boundaries 2 and 3 only.



Outlet 1

- 1 In the Physics toolbar click Boundaries  and choose Outlet .
The default outlet condition specifies a zero relative pressure.
- 2 Go to the Settings window for Outlet. Select Boundary 7 only.
- 3 In the Settings window for Outlet, locate the Pressure Conditions section. Select the Normal flow checkbox.

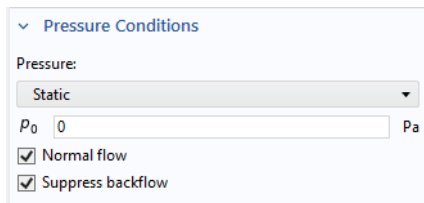

The sequence of nodes in the Model Builder under Laminar Flow should match the figure. The 'D' in the upper-left corner of a node means it is a default node.

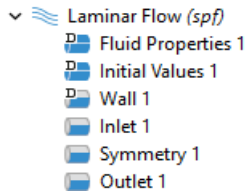

All other boundaries now have the default wall condition.

Mesh 1

- 1 In the Model Builder click Mesh 1 .
- 2 In the Settings window for Mesh, locate the Physics-Controlled Mesh section. From the Element size list, choose Coarse.

The physics-induced mesh automatically introduces a mesh that is a bit finer on the walls than the free stream mesh.

- 3 Click the Build All button .

The figure below shows the boundary layer mesh at the walls. Zoom in to the mesh using the zoom function in the Graphics toolbar  to confirm that it matches the figure.

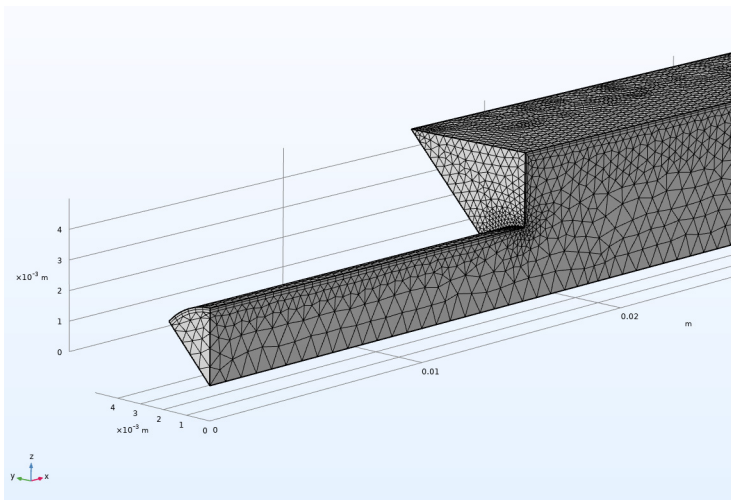
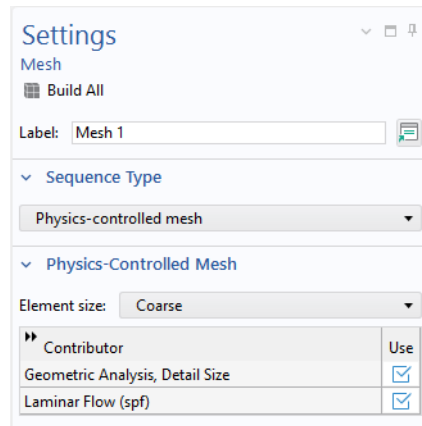

Study 1







- 1 In the Home toolbar click Compute .

When Compute is selected, COMSOL Multiphysics automatically chooses a suitable solver for the problem.

Results

Two plots are automatically created, one slice plot for the velocity and one pressure surface plot on the wall.

Velocity (spf)

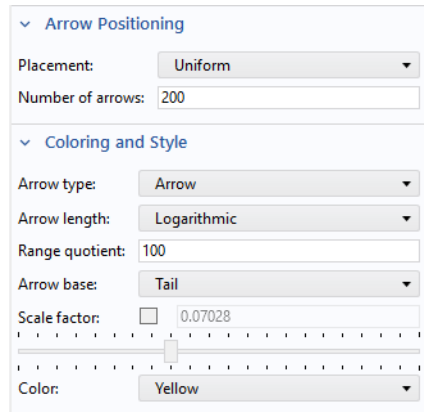

- 1 In the Model Builder under Results , expand the Velocity (spf)  node.
- 2 Right-click Multislice  and choose Delete. Click Delete to confirm.
- 3 Go to the Velocity (spf) toolbar and click Surface .
 - On the Velocity (spf) toolbar, click Arrow Surface .
- 4 Go to the Settings window for Arrow Surface.
 - Locate the Coloring and Style section. From the Arrow length list, select Logarithmic.
 - From the Color list, select Yellow. Click the Plot button  followed by the Zoom Extents button  in the Graphics window toolbar.





The plot in [Figure 8](#) displays in the Graphics window.

To see the recirculation effects, create a streamline plot of the velocity field.

3D Plot Group 3

- 1 In the Home toolbar click Add Plot Group  and choose 3D Plot Group .
- 2 In the Settings window for 3D Plot Group 3, type Velocity, Streamlines in the Label text field.
- 3 Go to the Velocity, Streamlines toolbar and click Streamline .
- 4 In the Streamline Settings window, scroll to the Selection section, and select Boundary 1 (the inflow boundary) only.
- 5 In the Settings window for Streamline locate the Coloring and Style section. From the Line type list, choose Tube.

6 Right-click Streamline 1  and choose Color Expression .

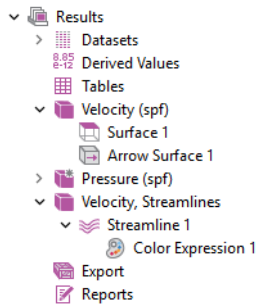

The plot in [Figure 9](#) displays in the Graphics window.

Tutorial Model — Water Purification Reactor

Water purification is a multiple step process for turning natural water into drinking water. At least one step must be a disinfectant step. One way to achieve efficient disinfection in an environmentally friendly way is to use ozone. A typical ozone purification reactor is about 40 m long and resembles a maze with partial walls or baffles that divide the space into room-sized compartments (Ref. 1). When water flows through the reactor, turbulent flow is created along its winding path around the baffles toward the exit pipe. The turbulence mixes the water with ozone gas, which enters through diffusers just long enough to deactivate micropollutants. When the water leaves the reactor, the remaining purification steps filter off or otherwise remove the reacted pollutants.

When analyzing an ozone purification reactor, the first step is to get an overview of the turbulent flow field. The results from the turbulent-flow simulation can then be used for further analyses of residence time and chemical species transport and reactions. This step requires adding more physics features to the model. The current application solves for turbulent flow in a water treatment reactor using the Turbulent Flow, k - ϵ interface.

Model Geometry

The model geometry along with some boundary conditions is shown in [Figure 10](#). The full reactor has a symmetry plane, which is utilized to reduce the size of the component.

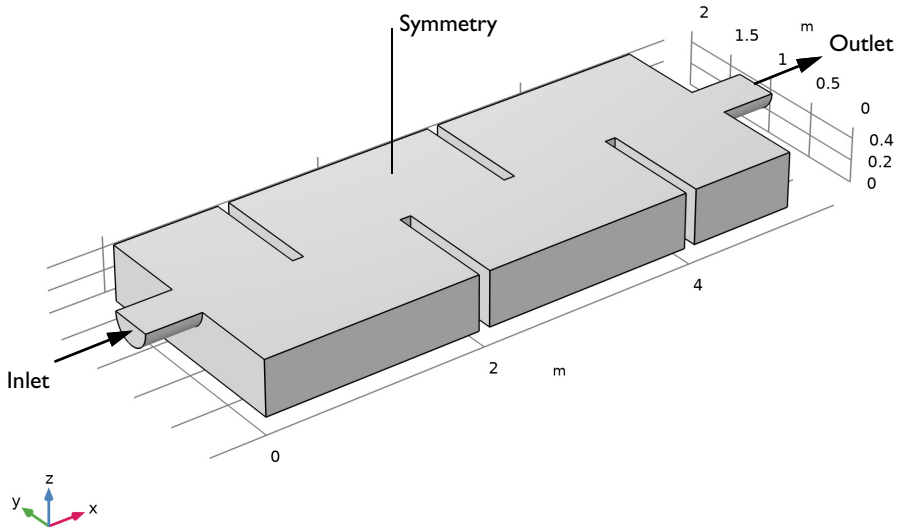

Figure 10: Model geometry. All boundaries except the inlet, outlet, and symmetry plane are walls.

Domain Equations and Boundary Conditions

Based on the inflow velocity, which is 0.1 m/s, and a length scale L equal to the diameter of the inlet, the Reynolds number is

$$\text{Re} = \frac{U \cdot L}{\nu} = \frac{0.1 \cdot 0.1}{1 \cdot 10^{-6}} = 1 \cdot 10^5$$

Here ν is the kinematic viscosity. The high Reynolds number clearly indicates that the flow is turbulent and a turbulence model must be applied. In this case, you will use the k - ϵ model. It is commonly used in industrial applications, because it is both relatively robust and computationally inexpensive compared to more advanced turbulence models. One major reason to why the k - ϵ model is inexpensive is that it employs wall functions to describe the flow close to walls instead of resolving the very steep gradients there. All boundaries are walls in [Figure 10](#) except the inlet, the outlet, and the symmetry plane.

The fully developed flow option is used as inlet boundary condition. A constant pressure is prescribed on the outlet.

Notes About the Implementation

A three-dimensional turbulent flow can take a rather long time to solve, even using a turbulence model with wall functions. To make this tutorial feasible, the mesh is deliberately selected to be relatively coarse and the results are hence not mesh independent. It is good practice to investigate the effect of refining the mesh in order to ensure that the model is well resolved.

Results

The velocity field in the symmetry plane is shown in [Figure 11](#). The jet from the inlet hits the edge of the first baffle, which splits the jet. One half creates a strong recirculation zone in the first “chamber”. The other half continues downstream into the reactor and gradually spreads out. The velocity magnitude decreases as more fluid is entrained into the jet.

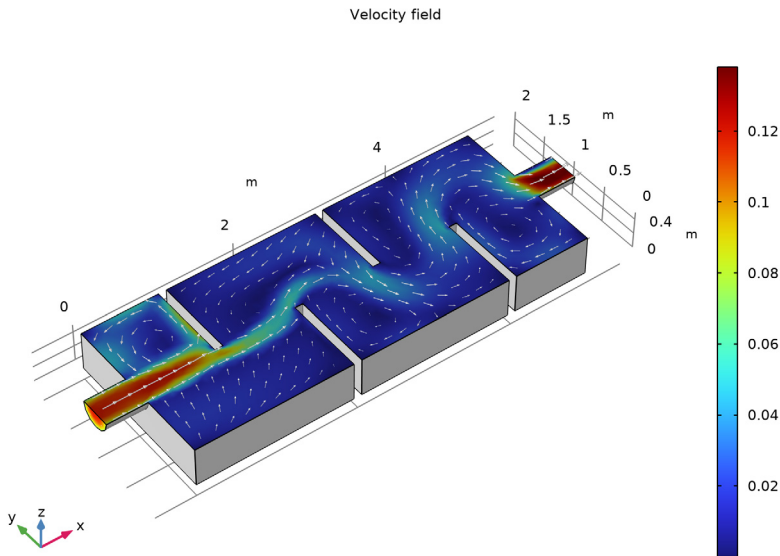

Figure 11: Velocity field in the symmetry plane.

[Figure 12](#) gives a more complete picture of the mixing process in the reactor. The streamlines are colored by the velocity magnitude, and their widths are proportional to the turbulent viscosity. Wide lines hence indicate a high degree of

mixing. The turbulence in this model is mainly produced in the shear layers between the central jet and the recirculation zones. The mixing can be seen to be relatively weak near the entrance to the reactor and to increase further downstream.

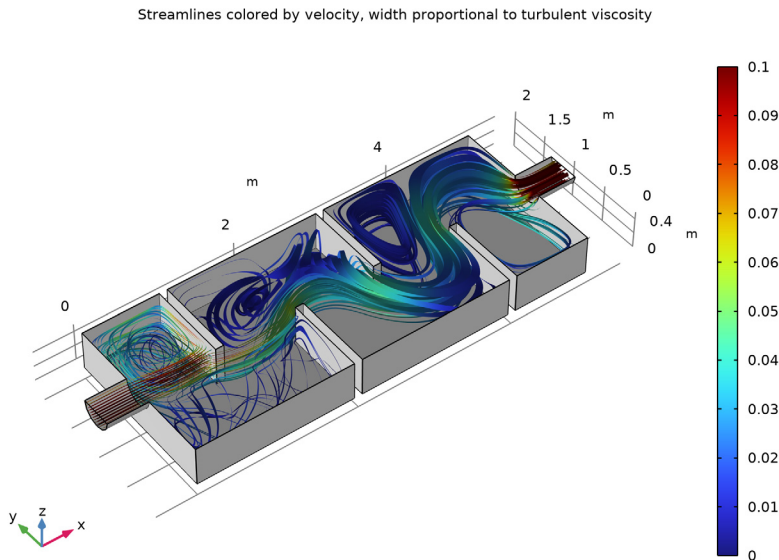







Figure 12: Streamlines colored by velocity. The width of the streamlines is proportional to the turbulent viscosity.

Reference

I. J. Hofman, D. Wind, B. Wols, W. Uijttewaal, H. van Dijk, and G. Stelling, “The use of CFD Modeling to determine the influence of residence time distribution on the disinfection of drinking water in ozone contactors,” COMSOL Conference 2007, Grenoble, 2007; www.comsol.com/story/fine-tuning-for-water-purification-22621.



Model Wizard

The first step to build an application is to open COMSOL Desktop, then select the physics interface and specify the type of analysis you want to do — in this case, a stationary, Turbulent Flow, k-ε analysis.

- 1 Open COMSOL Multiphysics. On the New page click Model Wizard . Then click the 3D button .
- 2 In the Select Physics tree under Fluid Flow > Single-Phase Flow > Turbulent Flow, click Turbulent Flow, k- ϵ (spf) .
- 3 Click Add and then click the Study button .
- 4 In the tree under General Studies, click Stationary .
- 5 Click the Done button .

Global Definitions — Parameters

The first task is to define a parameter for the inlet velocity. Parameters can be used to run parametric studies.

- 1 In the Home toolbar click Parameters  and select Parameter 1 . The Home toolbar refers to the specific set of controls near the top of the Desktop.
- 2 Go to the Settings window for Parameters. In the table, enter the following settings:
 - In the Name text field, enter `u_in`.
 - In the Expression text field, enter `0.1[m/s]`.
 - In the Description text field, enter `Inlet velocity`.

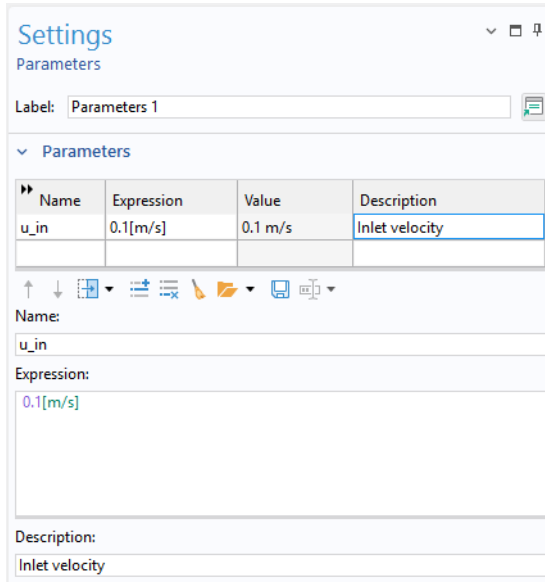

Settings
Parameters

Label: Parameters 1

Name	Expression	Value	Description
u_in	0.1[m/s]	0.1 m/s	Inlet velocity

Name:
u_in

Expression:
0.1[m/s]



Description:
Inlet velocity

Geometry I

You can build the reactor geometry from geometric primitives. Here, instead use a file containing the sequence of geometry features that has been provided for convenience.

Note: The location of the file used in this exercise varies based on your installation. For example, if the installation is on your hard drive, the file path might be similar to



C:\Program Files\COMSOL\COMSOL64\Multiphysics\applications\.

- 1 In the Geometry toolbar click Insert Sequence .
- 2 Browse to the application library folder and double-click the file \CFD_Module\Single-Phase_Flow\water_purification_reactor_geom_sequence.mph.
- 3 In the Home toolbar click Build All .

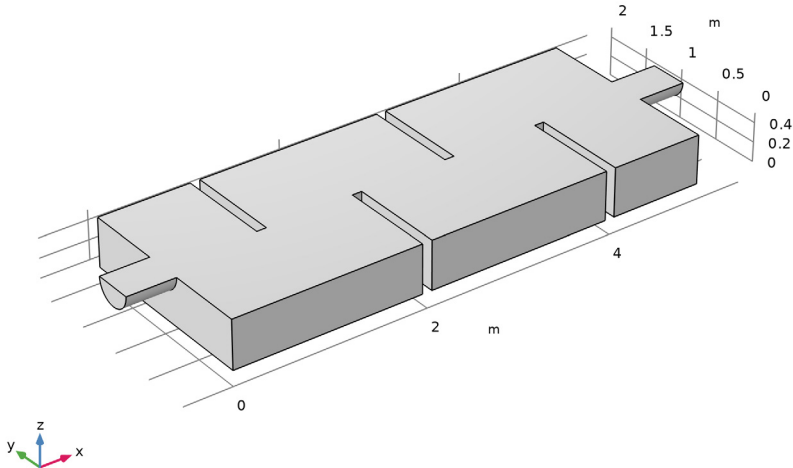
The geometry sequence is now inserted into your component and should look like the figure below.



Materials



- 1 In the Home toolbar click Add Material .
- 2 Go to the Add Material window. In the tree under Built-In click Water, liquid .
- 3 In the Add Material window, click + Add to Component.
- 4 In the Home toolbar, click Add Material  again to close the window.

The physical properties are now available for the CFD simulation. The next step is to specify the domain and boundary conditions.

Turbulent Flow, k- ϵ

The Fluid Properties 1 node specifies the domain equations and by default uses the material properties specified by the Water, liquid material selected in the previous steps.

Inlet 1

- 1 In the Physics toolbar click Boundaries  and choose Inlet .
- 2 Select Boundary 1, which represents the inlet.
- 3 In the Settings window for Inlet, locate the Boundary Condition section. From the list, choose Fully developed flow.
- 4 Locate the Fully Developed Flow section. In the U_{av} text field, type u_{in} .

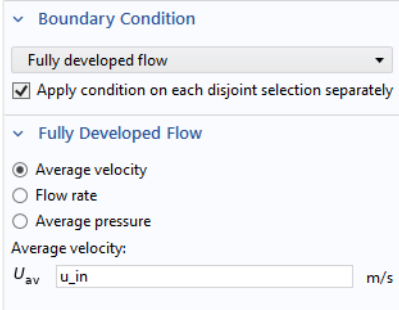

Boundary Condition

Fully developed flow

Apply condition on each disjoint selection separately

Fully Developed Flow

Average velocity



Flow rate

Average pressure



Average velocity:

U_{av} m/s

Symmetry 1

- 1 In the Physics toolbar click Boundaries  and choose Symmetry .
- 2 Select Boundary 3 only.

Outlet 1

- 1 In the Physics toolbar click Boundaries  and choose Outlet .
- 2 Select Boundary 28 only.

The sequence of nodes in the Model Builder under Turbulent Flow, k-ε should match the figure. The ‘D’ in the upper left corner of a node means it is a default node.

All boundaries not selected in Inlet 1, Symmetry 1, or Outlet 1 now have the default wall condition.

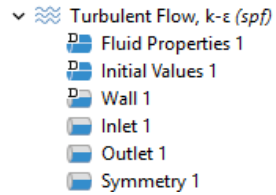

Mesh 1

The physics-induced mesh automatically introduces a mesh that is a bit finer on the walls than the free stream mesh. It also refines the mesh at sharp corners and adds a boundary layer mesh. The finer mesh on the walls is not critical in this model since most of the turbulence is produced in the shear layers between the jet and the recirculation zones. The boundary layer mesh can also be coarsened in order to save computational time.

- 1 In the Model Builder under Component 1 click Mesh 1 .
- 2 In the Settings window for Mesh, locate the Physics-Controlled Mesh section. From the Element size list, choose Coarser.

Size 2

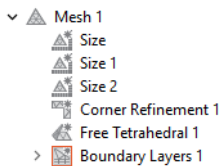

- 1 Go to the Mesh toolbar and click Edit .

A mesh sequence as shown below appears. It contains suggestions made by the physics interface. The asterisk on each of the mesh features indicates that the features are not yet built.



- 2 Right-click Size 2  and choose Disable .

Boundary Layer Properties 1

- 1 In the Model Builder, expand the Component 1 > Mesh 1 > Boundary Layers 1  node, then click Boundary Layer Properties 1 .
- 2 In the Settings window for Boundary Layer Properties locate the Boundary Layer Properties section.
 - In the Number of boundary layers text field, type 2.
 - In the Thickness adjustment factor text field, type 6.
- 3 Click the Build All  button.
- 4 In the Model Builder, collapse the Mesh 1 node.

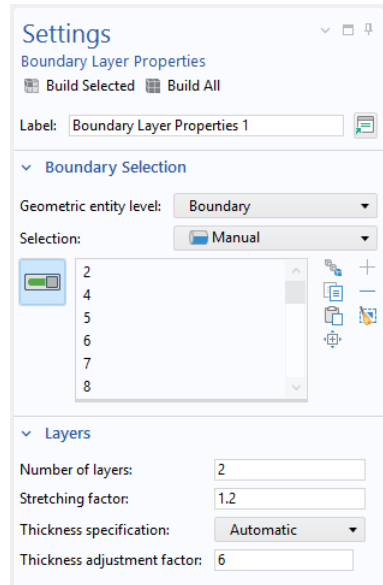

The mesh is now complete and should match the figure below. The mesh can differ slightly depending on which computer architecture you use. The mesh in

the figure is built on a Windows computer, and will look similar, but not identical, if built on, for example, a Mac or Linux computer.

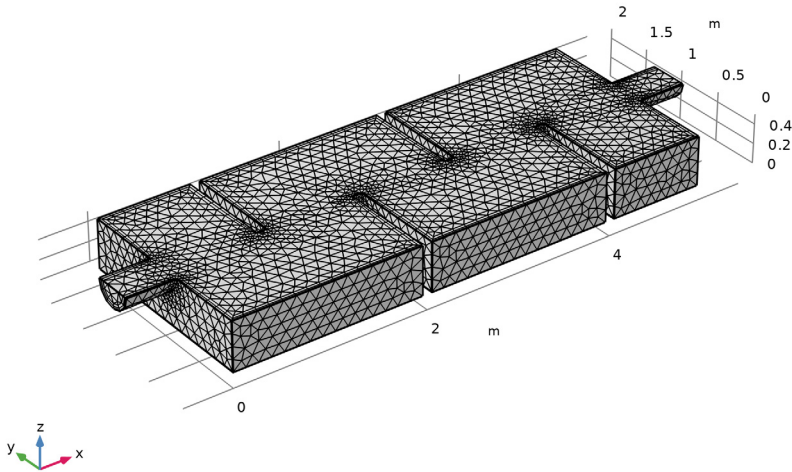

Study I

Next, solve for the flow field. This takes approximately 15 minutes on a quad-core desktop computer.

■ In the Home toolbar click Compute .









When Compute is selected, COMSOL Multiphysics automatically chooses a suitable solver for the problem.

Results

Three plots are automatically created, one slice plot for the velocity, one pressure surface plot on the walls and one boundary plot of the wall lift-off in viscous units for the wall functions. The last one is important since it gives an indication of how well resolved the flow is at the walls. See [Theory for the Turbulent Flow Interfaces](#) in the *CFD Module User's Guide* for further details on wall functions.

The following steps reproduce [Figure 11](#).

Velocity (spf)

- 1 In the Model Builder window, under Results click Velocity (spf) .
- 2 In the Settings window for 3D Plot Group, click to expand the Selection section.
- 3 From the Geometric entity level list, choose Boundary.
- 4 Select Boundaries 1, 3 and 28, corresponding to the inlet, symmetry plane and outlet boundaries.
- 5 In the Model Builder window, expand the Velocity (spf)  node.
- 6 Right-click Multislice  and choose Delete. Click Delete to confirm.
- 7 In the Velocity (spf) toolbar click Surface  to generate a surface plot of the velocity magnitude.
- 8 In the Velocity (spf) toolbar click Arrow Surface .
- 9 In the Settings window for Arrow Surface, locate the Arrow Positioning section. In the Number of arrows text field, type 300.
- 10 In the Settings window for Arrow Surface, locate the Coloring and Style section.
 - From the Arrow length list, choose Logarithmic.
 - Select the Scale factor checkbox. In the associated text field, type 1.4.
 - From the Color list, choose White.
- 11 In the Velocity (spf) toolbar click Surface .
- 12 In the Settings window for Surface, locate the Expression section and type 1 in the Expression text field.
- 13 Locate the Coloring and Style section.
 - From the Coloring list, choose Uniform.
 - From the Color list, choose Gray.
- 14 Right-click Surface 2 and choose Selection .
- 15 In the Settings window for Selection, locate the Selection section.
- 16 From the Selection list, choose Box Selection: Walls.
- 17 In the Model Builder click Velocity (spf) .

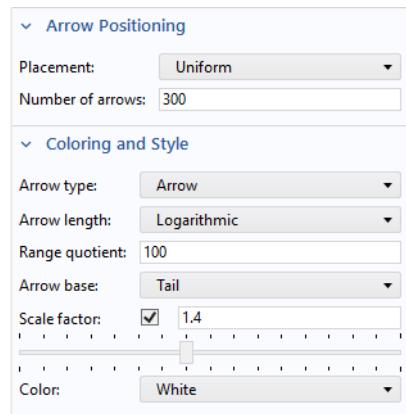

- 18** In the Settings window for 3D Plot Group, click to expand the Title section.
- From the Title type list, choose Manual.
 - In the Title text area, type `Velocity field`.



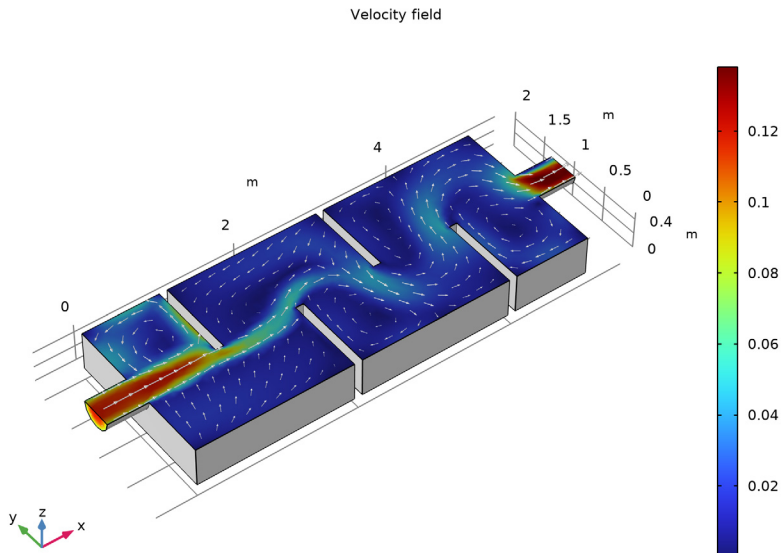

19 Click the Plot button .



Also reproduce [Figure 12](#) as follows.



- 1** In the Model Builder under Velocity (spf), right-click Surface 2 and choose Copy .

3D Plot Group 4

- 1** In the Home toolbar click Add Plot Group  and choose 3D Plot Group .
- 2** In the Model Builder right-click 3D Plot Group 4  and choose Paste Surface .
- 3** In the 3D Plot Group 4 toolbar click Streamline .
- 4** In the Settings window for Streamline, go to the Selection section and select Boundary 1, which is the inlet. The streamlines now start at this boundary.

5 In the Settings window for Streamline:

- Locate the Streamline Positioning section. In the Number text field, type 45.
- Locate the Coloring and Style section. Find the Line Style subsection. From the Type list, choose Ribbon.
- In the Width expression text field, type $\text{spf.nuT} \cdot 1 [\text{s/m}]$. The width of the streamlines is set to the local value of the turbulent viscosity and the factor $1 [\text{s/m}]$ is used to get the right dimension.
- Select the Width scale factor checkbox. In the associated text field, type 100.

6 Right-click Results > 3D Plot Group 4 > Streamline 1  and choose Color Expression .

7 In the Settings window for Color Expression, click to expand the Range section.

- Select the Manual color range checkbox.
- In the Minimum text field, type 0.
- In the Maximum text field, type 0.1.

8 In the Model Builder click 3D Plot Group 4 .

9 In the Settings window for 3D Plot Group, locate the Title section.

- From the Title type list, choose Manual.
- In the Title text area, type Streamlines colored by velocity, width proportional to turbulent viscosity.

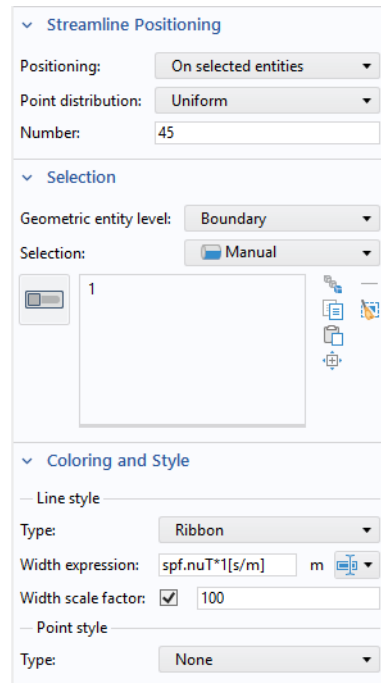

10 In the 3D Plot Group 4 toolbar click Plot .

Streamlines colored by velocity, width proportional to turbulent viscosity

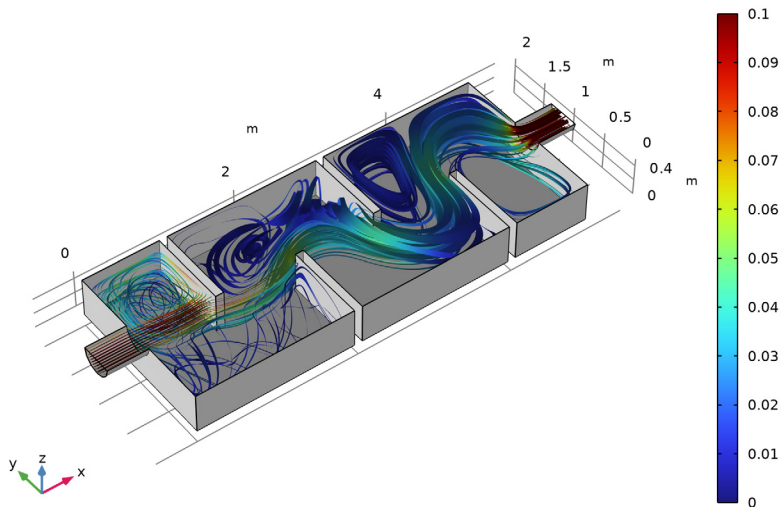

11 In the Label text field, type Streamlines.

This concludes the introduction to the COMSOL CFD Module.