

# INTRODUCTION TO CAD Import Module

# Introduction to the CAD Import Module

© 2005–2025 COMSOL

Protected by patents listed on [www.comsol.com/patents](http://www.comsol.com/patents), or see Help > About COMSOL Multiphysics on the File menu in the COMSOL Desktop for less detailed lists of U.S. Patents that may apply. Patents pending.

This Documentation and the Programs described herein are furnished under the COMSOL Software License Agreement ([www.comsol.com/comsol-license-agreement](http://www.comsol.com/comsol-license-agreement)) and may be used or copied only under the terms of the license agreement. Portions of this software are owned by Siemens Industry Software, Inc. © 1986–2025. All Rights Reserved. Portions of this software are owned by Spatial Corp. © 1989–2025. All Rights Reserved.

COMSOL, the COMSOL logo, COMSOL Multiphysics, COMSOL Desktop, COMSOL Compiler, COMSOL Server, and LiveLink are either registered trademarks or trademarks of COMSOL AB. ACIS and SAT are registered trademarks of Spatial Corporation. CATIA is a registered trademark of Dassault Systèmes or its subsidiaries in the US and/or other countries. Parasolid is a trademark or registered trademark of Siemens Industry Software, Inc. or its subsidiaries in the United States and in other countries. All other trademarks are the property of their respective owners, and COMSOL AB and its subsidiaries and products are not affiliated with, endorsed by, sponsored by, or supported by those or the above non-COMSOL trademark owners. For a list of such trademark owners, see [www.comsol.com/trademarks](http://www.comsol.com/trademarks).

Version: COMSOL 6.4

## Contact Information

Visit the Contact COMSOL page at [www.comsol.com/contact](http://www.comsol.com/contact) to submit general inquiries or search for an address and phone number. You can also visit the Worldwide Sales Offices page at [www.comsol.com/contact/offices](http://www.comsol.com/contact/offices) for address and contact information.

If you need to contact Support, an online request form is located on the COMSOL Access page at [www.comsol.com/support/case](http://www.comsol.com/support/case). Useful links:

- Support Center: [www.comsol.com/support](http://www.comsol.com/support)
- Product Download: [www.comsol.com/product-download](http://www.comsol.com/product-download)
- Product Updates: [www.comsol.com/product-update](http://www.comsol.com/product-update)
- COMSOL Blog: [www.comsol.com/blogs](http://www.comsol.com/blogs)
- Discussion Forum: [www.comsol.com/forum](http://www.comsol.com/forum)
- Events: [www.comsol.com/events](http://www.comsol.com/events)
- COMSOL Video Gallery: [www.comsol.com/videos](http://www.comsol.com/videos)
- Support Knowledge Base: [www.comsol.com/support/knowledgebase](http://www.comsol.com/support/knowledgebase)
- Learning Center: [www.comsol.com/support/learning-center](http://www.comsol.com/support/learning-center)

Part number: CM020302

# Contents

---

Introduction .....	5
About CAD File Formats .....	6
The Geometry Cleanup Wizard .....	8
Removing Small Geometric Entities with Repair .....	18
Removing Small Geometric Entities with the Defeating Tools	22
Creating Modeling Domains Around an Imported Geometry.	31



## Introduction

---

This guide introduces you to the CAD Import Module, which adds support for importing several 3D CAD file formats into the COMSOL modeling environment. It also provides a robust platform, including repair and defeaturing tools, to prepare the geometry for multiphysics modeling. The detailed tutorials that follow start you off with becoming efficient in using the provided functionality.

## About CAD File Formats

---

To better understand the functionality of the CAD Import Module, first review some general background information about CAD file formats.

### **CAD Software, Geometry Kernels, and File Formats**

---

Each CAD program uses a geometry kernel to create a mathematical description of the objects and to calculate the results of solid-modeling operations. Parasolid<sup>®</sup> and ACIS<sup>®</sup> are the two most common kernels, and many CAD programs license these kernels. In addition, some programs use their own kernel (as does COMSOL). Each of these kernels has a native file format associated with it. For example, the Parasolid file format is simply called Parasolid, and the one from ACIS is called ACIS or SAT<sup>®</sup>.

The geometry kernel defines the type of internal representations used for 3D modeling, which can vary considerably among different kernels. That explains why the representations stored in the various file formats are also very different. The CAD Import Module can read several of these different descriptions of objects and translate them into a format that COMSOL can work with.

In addition to the file formats that are native to a geometry kernel, yet other formats are based on neutral standards that were defined to ease the exchange of geometric models among CAD software applications. STEP and IGES are the two most popular such formats.

Yet another class of files use surface-mesh geometry formats. They do not represent a model's exact 3D geometry; instead, they store only triangular meshes of the surfaces. The most common examples of these types of formats are STL and 3MF.

### **Translating 3D CAD Files Between Formats**

---

Geometric models do not always pass flawlessly between different file formats due to the fact that they are represented differently. This means that the quality of a translation when importing a file to COMSOL depends on the file format. The smoothest way is to use the native format of your CAD system. If this is not an option, we in general recommend that you use Parasolid, STEP, or ACIS.

Importing 3D CAD files into COMSOL is straightforward. Since the settings of the import operation have been tuned to suit the most common cases, the

majority of files import simply with the click of a button. During import the geometry is checked for errors and automatically repaired. The repair operation also removes small features that fall within the import tolerance.

# The Geometry Cleanup Wizard

---

This tutorial demonstrates the use of the Geometry Cleanup Wizard to defeature the geometry of a wheel rim imported from a Parasolid® file. The Geometry Cleanup is capable of automatically identifying and eliminating small geometric details, such as small faces, sliver faces, short edges, thin domains, and gaps in the geometry. One of the actions that the cleanup tool can use is the Remove Details operation, which utilizes virtual geometry operations that can set geometric entities, such as vertices, edges, or faces, to be ignored by the mesher. Since selected elements are “hidden” from the mesher, meshing takes place on a virtual geometry, hence the name virtual operations.

Virtual operations work on the finalized geometry, that is, the geometry after the Form Union or Form Assembly nodes. This means that using these operations you can remove small domains that result from intersecting solid objects. Another benefit is that they keep the curvature of the geometry, which may be important when removing larger faces, or for certain physics applications where altering the curvature of the geometry can, for example, give rise to stress concentrations.

## Model Wizard

---

- 1 Start COMSOL Multiphysics.
- 2 Select Blank Model to skip the steps of selecting physics interfaces and study type.
- 3 In the Home toolbar, click Add Component  and select 3D.

## Importing the Geometry

---

Before importing the CAD file, make sure that the CAD kernel is used.

- 1 In the Model Builder window, under Component 1 (comp1) click Geometry 1.
- 2 In the Settings window for Geometry, from the Geometry representation list, choose CAD kernel.
- 3 In the Home toolbar, click Import .
- 4 In the Settings window for Import, click Browse.
- 5 In your COMSOL installation directory navigate to the folder `applications/CAD_Import_Module/Tutorial_Examples` and double click the file `wheel_rim.x_b`.

## 6 Click Import.

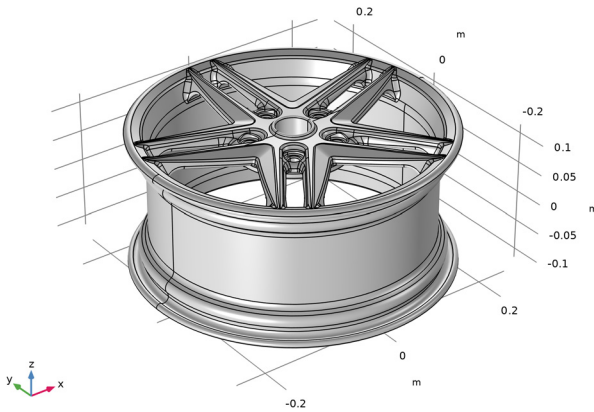

## Geometry Cleanup

---

When leaving the geometry branch of the model tree, the geometry is automatically analyzed for small details.

- 1 In the Model Builder window, under Component 1 click Mesh 1.
- 2 In the Geometry Cleanup dialog that opens, click Open Wizard to open the Cleanup Wizard, to review the detected details and cleanup steps, and to modify the used tolerance.

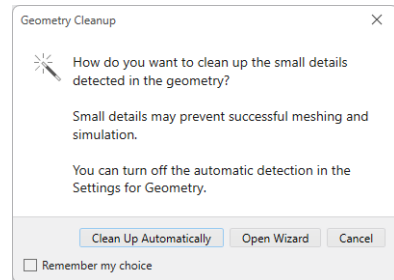

The Cleanup can identify narrow face regions, sliver faces, small faces, short edges, narrow domain regions, and gaps. These issues are highlighted in the Graphics when the Remaining details section is active. Since this geometry has sector symmetry, the same small details are present around all of the spokes. Increase the Detail size used for the cleanup to detect more details to remove.

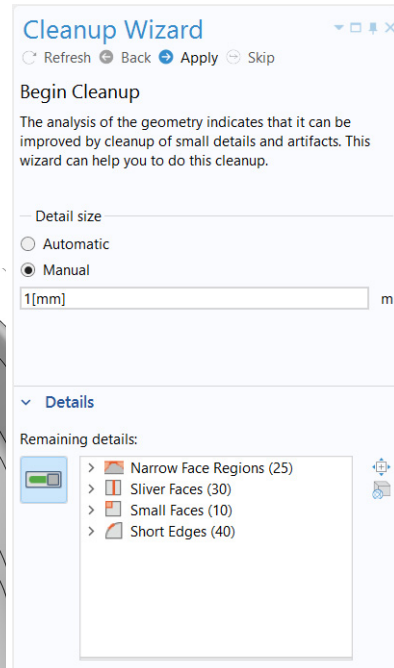
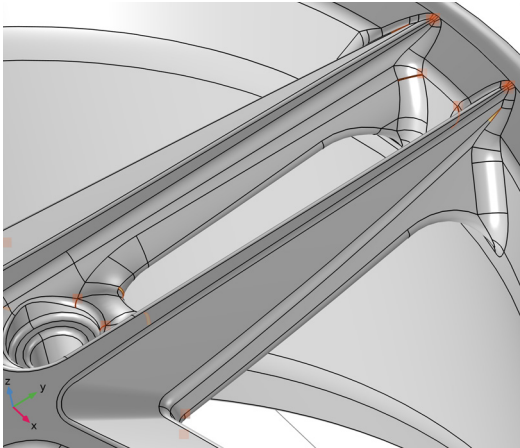

- 3 Go to the Cleanup Wizard window and click the Manual button.
- 4 In Detail size text field, type 1 [mm].
- 5 Click the Refresh  button in the window toolbar. Zoom in and rotate the rim to see some of the detected details around two of the spokes, as in the view below.



There are four types of details in the geometry: narrow face regions, sliver faces, small faces, and short edges.

- 6 Expand the sections corresponding to the detected detail types in the list. It is now possible to select the details to highlight them on the screen.
- 7 In the tree, select Sliver Faces (30) > Face 406 (3.1E-4 m) and click  Zoom to selection to zoom in on this face for a closer inspection.  
Before proceeding with the cleanup process, mesh the geometry to observe the effects of the cleanup later.
- 8 Go to Mesh 1 and click Build All  .

9 Zoom out to see the mesh around the two spokes as in the figure below.

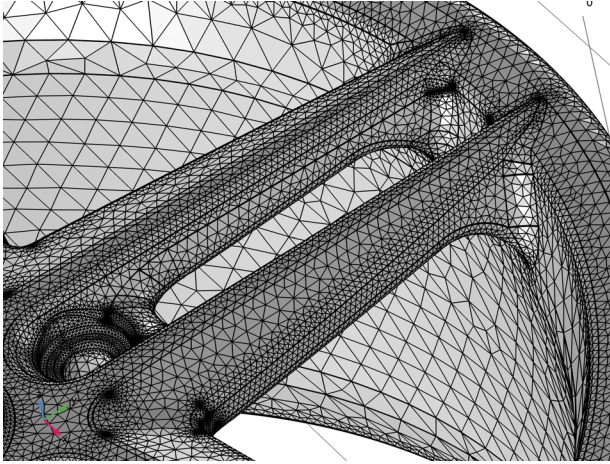

The mesh resolves well the small geometric details but it is quite large with close to 600,000 domain elements. Notice the dense mesh regions that appear as dark spots at the location of small details. Changing the element size to a coarser setting can reduce the number of elements, but this usually also leads to lower mesh element quality due to the presence of the small geometric details.

10 In the settings window for Mesh, locate the Physics Controlled Mesh section. From the Element size list, choose Extra coarse and click Build All .

This results in a mesh with about 200,000 tetrahedral elements, but the dense mesh regions remain as the mesh generator tries to resolve the details even with this coarser setting. The two information nodes that appear below the Mesh 1 node indicate that some edges and faces are much smaller than the minimum elements size setting.

Return to the Cleanup Wizard to see how the mesh can be improved by removing the small details.

- 11 Go to the Cleanup Wizard window and click Apply in the window toolbar to apply the specified detail size.

This opens the next page in the wizard that suggests to add a Remove Details operation to handle the detected details.

- 12 Click the Apply button again in the window toolbar to add and build the Remove Details node.

The Remove Details operation is a collection of virtual operations that simplify the geometry for meshing. How this is done by the sequence of operations added under Remove Details is explored in the next section of this tutorial.

The cleanup is now completed and all detected small details have been removed.

- 13 Click Done in the toolbar to close the Cleanup Wizard window.

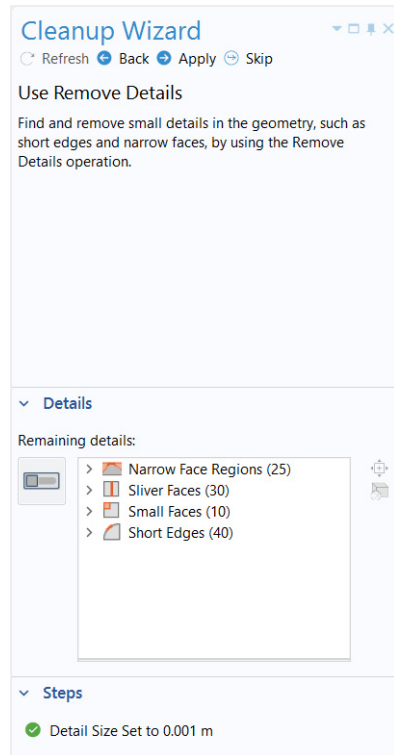

14 A Cleanup Log  node is added last in the geometry sequence, and it becomes selected with its Settings window open.

This is where you can find information about the actions performed by the geometry cleanup process. In this case, it only added a Remove Details operation, but for more complex geometries, this list can be longer. When selecting a modification in the list you can use the buttons under the table to easily go to the node in the model tree to review the changes, and to revert some or all of the modifications. Restarting the Cleanup Wizard can also be done with the button in the window toolbar.

15 In the Model Builder window, click on Mesh 1 and choose Build All .

Notice that the dense mesh regions no longer appear in this mesh of approximately 160,000 domain elements. The information nodes do not appear either under the Mesh 1 node, implying that mesh element quality has improved compared to the previous mesh.

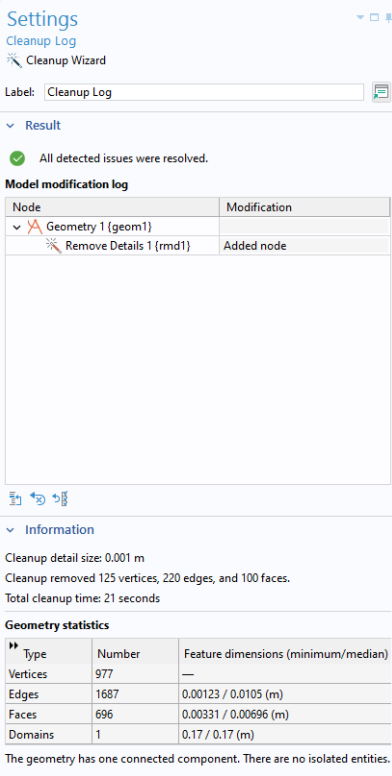

**Settings**  
Cleanup Log  
Cleanup Wizard

Label: Cleanup Log

**Result**

All detected issues were resolved.

**Model modification log**

Node	Modification
Geometry 1 {geom1}	
Remove Details 1 {rmd1}	Added node

**Information**

Cleanup detail size: 0.001 m  
Cleanup removed 125 vertices, 220 edges, and 100 faces.  
Total cleanup time: 21 seconds

**Geometry statistics**

Type	Number	Feature dimensions (minimum/median)
Vertices	977	—
Edges	1687	0.00123 / 0.0105 (m)
Faces	696	0.00331 / 0.00696 (m)
Domains	1	0.17 / 0.17 (m)

The geometry has one connected component. There are no isolated entities.

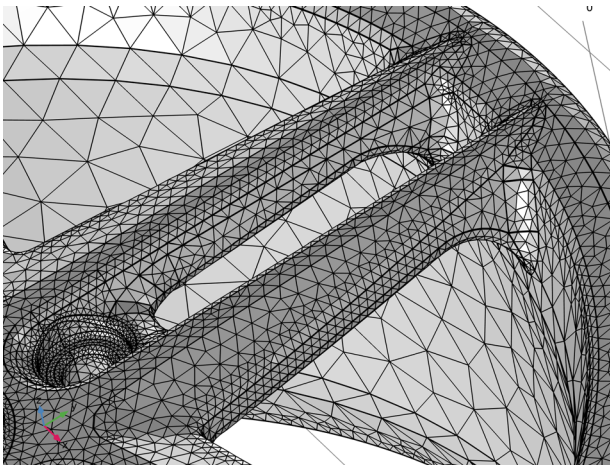

# Manual Mode for Remove Details

Automatic geometry cleanup is convenient as it saves time by automatically determining suitable tolerances and operations to remove geometric detail before meshing. Reviewing and modifying the Remove Details operation added for cleaning up this wheel rim geometry is possible by switching to manual mode.

- 1 Click the Remove Details 1  node in the Model Builder.
- 2 In the Settings window, locate the Mode of operation list and set it to Manual.
- 3 Expand the sequence to reveal the automatically generated sequence of virtual geometry operations.

In manual mode you can examine and edit each individual operation. You could, for example, exclude entities that you do not want to remove from the geometry. You could also add further virtual operations to the automatically generated sequence to remove additional entities.

Details are removed in different passes using increasing tolerances to remove larger and larger details. A simple geometry may only need one pass, but with a more complex geometry, like this wheel rim, the Remove Details operation goes through several passes and a cleanup pass at the end. Take a closer look at some of the virtual operations in the sequence.

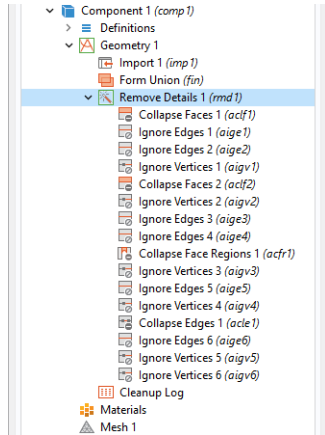

- 4 In the Model Builder window, under Component 1 (comp1)>Geometry 1>Remove Details 1 (rmd1) click Collapse Faces 1 (acfl1) .
- 5 In the Settings window for Collapse Faces, under Faces to collapse, toggle the  Activate Selection toggle button.

6 Use the Zoom to Selection  button to find some of the faces on the rim.

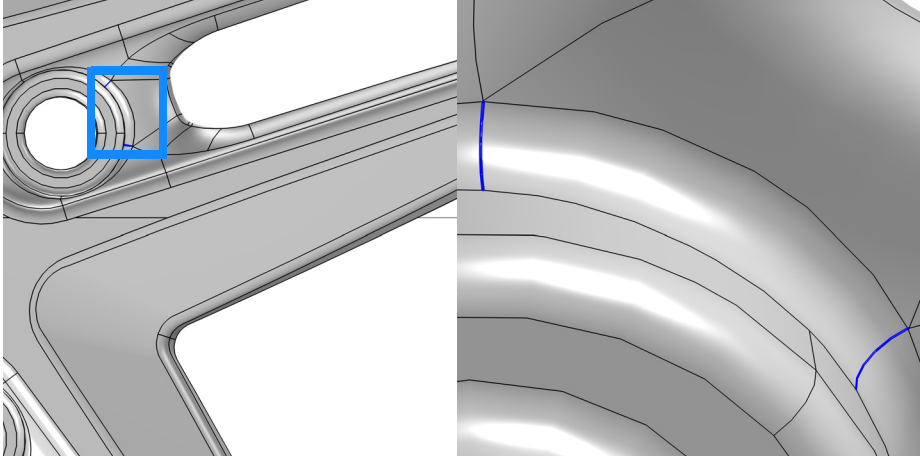

Both small faces and sliver faces are removed in this operation. Small faces with sides that are similar in length are usually collapsed into a vertex, whereas sliver faces that have a high aspect ratio are more often collapsed into one of the longer edges. As an alternative to the Collapse Faces operation you can also use the *Merge Edges* operation that gives more control over which edges are kept when collapsing faces.

7 Click the Build Selected  button.

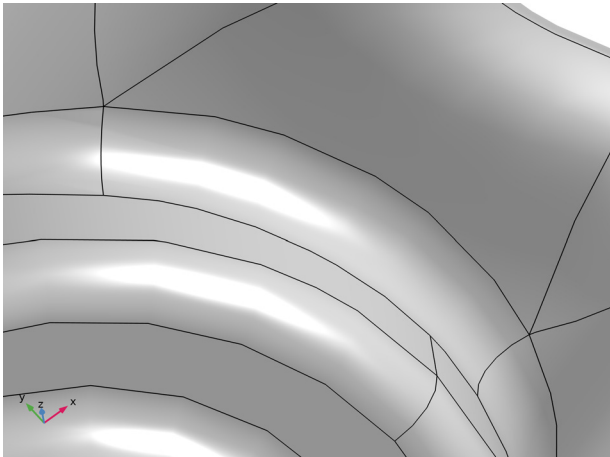

8 In the Model Builder window, click Ignore Edges 3 (aige3) .

- 9 In the Settings window for Ignore Edges toggle the  Activate Selection toggle button, then find some of the edges on the geometry by using Zoom to Selection .

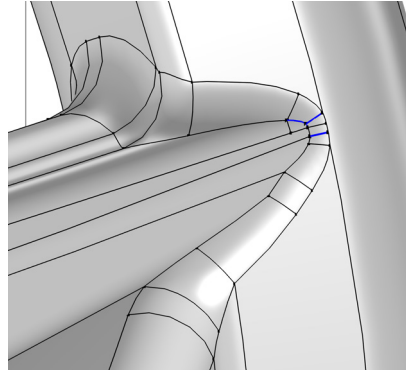

All edges in the list are next to sliver faces, similarly to the image displayed to the right. The sliver faces are wider compared to those that were collapsed in the previous operation. The faces on the two sides of the edge are continuous across the edge, and it is thereby suitable to form a larger composite face by ignoring the edge.

As an alternative to the Ignore Edges operation you can also use the *Form Composite Faces* operation.

- 10 Click the Build Selected  button. The geometry in the Graphics window is updated with the newly formed composite faces.

When removing edges, the adjacent vertices are deleted by downstream Ignore Vertices operations in the sequence. The sequence of virtual operations generated by Remove Details includes several Ignore Edges and Ignore Vertices operations to remove slivers with increasing face width.

In the following take a closer look at the *Collapse Face Regions* operation, that is added to the sequence to detect and remove narrow face regions.

- 11 In the Model Builder window, click Collapse Face Regions 1 (acfr1) .

- 12 In the Settings window toggle the  Activate Selection toggle button.

The face with the narrow regions is on the back of the rim.

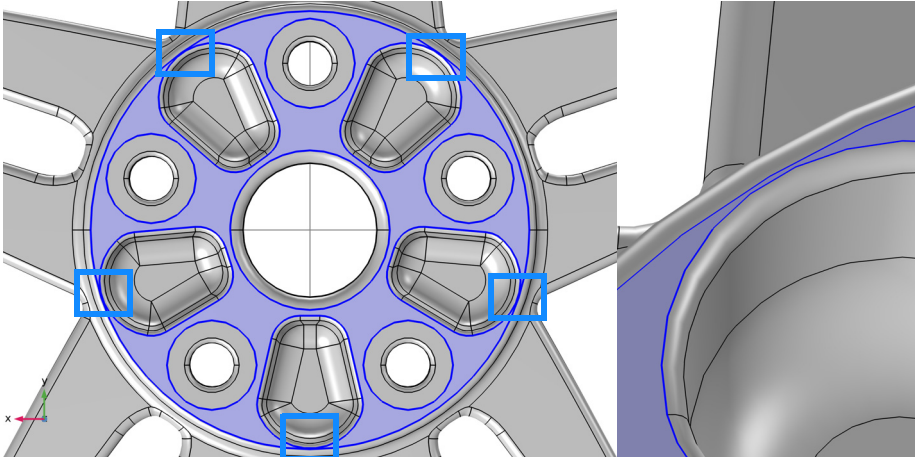

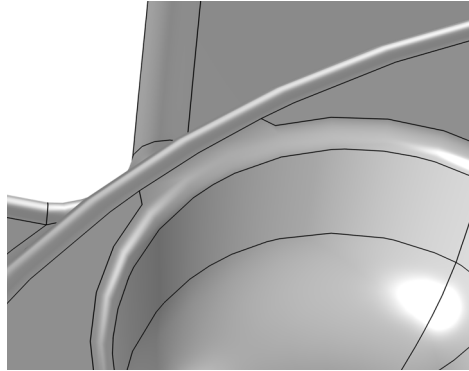

- 13** Click Build Selected  in the Settings window for Collapse Face Regions.

The operation removes a detected narrow region by first partitioning the edges adjacent to it by creating vertices. Then, new edges are created between the vertices to partition the face. This creates a sliver face in place of the narrow region. As the last step, the created sliver face is collapsed into an edge.



Finally, switch Remove Details back to automatic mode, and mesh the geometry.

- 14** In the Model Builder window, click Remove Details 1 (rmd1) .
- 15** In the Settings window for Remove Details, locate the Mode of operation list and set it to Automatic.
- 16** In the Mesh toolbar, click  Build All.

## Removing Small Geometric Entities with Repair

---

The step-by-step instructions in this tutorial demonstrate how small geometric details can be removed from imported CAD objects using the Repair operation. A difference when compared to the Remove Details operation used in the previous tutorial is that Repair is applied to geometric objects, which can then be exported to CAD formats, such as IGES, STEP, ACIS<sup>®</sup>, and Parasolid<sup>®</sup>. Remove Details uses virtual geometry operations with a resulting virtual geometry that cannot be exported to the mentioned CAD formats.

### Model Wizard

---

- 1 Start COMSOL Multiphysics.
- 2 Select Blank Model to skip the steps of selecting physics interfaces and study type.
- 3 In the Home toolbar, click Add Component  and select 3D.

### Importing the Geometry

---

This tutorial uses the wheel rim geometry that appeared in the previous example. Make sure that the CAD Import Module geometry kernel is used.

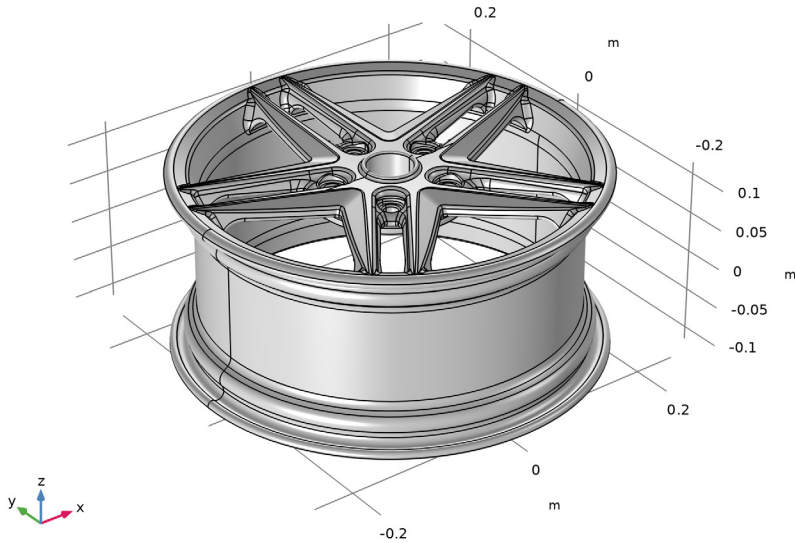

- 1 In the Model Builder window, under Component 1 (comp1) click Geometry 1.
- 2 In the Settings window for Geometry, from the Geometry representation list, choose CAD kernel.
- 3 In the Home toolbar click Import .
- 4 In the Settings window for Import click the Browse button.
- 5 In your COMSOL installation directory navigate to the folder `applications/CAD_Import_Module/Tutorial_Examples` and double click the file `wheel_rim.x_b`.
- 6 Click Import.

As soon as the import is done the geometry appears in the Graphics window.



## Repairing the Geometry

---

- 1 In the Geometry toolbar click Defeaturing and Repair  and choose Repair .
- 2 In the Graphics window select the wheel rim to add it to the Input objects list.
- 3 In the Absolute repair tolerance text field enter 1 [mm].

Absolute repair tolerance:  
 m

By keeping the repair tolerance close to the size of the features to be removed you can avoid removing anything else and breaking the geometry. In this case, the detail size for this wheel rim geometry is known from the previous example. In addition to using the Geometry Cleanup Wizard to determine the size of small details, you can also measure the size of geometric entities using the Measure tool found in the Geometry toolbar.

- 4 Click Build All Objects  to perform the operation.

- 5 Examine the geometry. Pan and zoom to take a look at the areas that contained the slivers and small faces, which are now no longer present in the geometry.

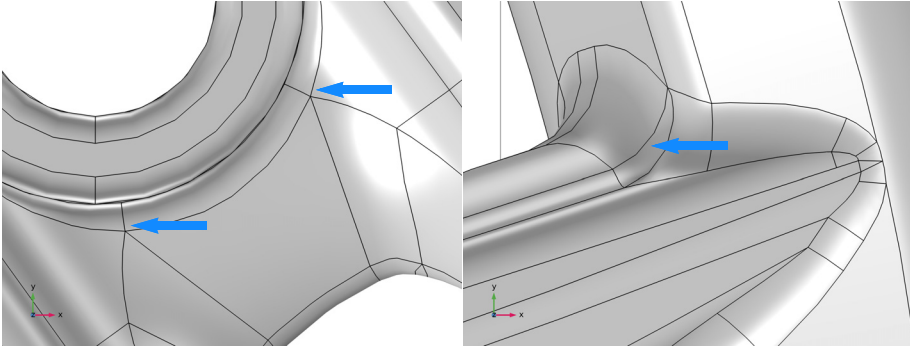



The small faces and slivers are no longer present in the geometry. According to the Information section in the Settings window for Repair, 100 short edges and 18 sliver faces were removed.

## Generating a Tetrahedral Mesh

---

Now that the defeaturing is completed, create a volume mesh for the wheel rim.

- 1 In the Model Builder window, under Component 1 click Mesh 1.  
The Geometry Cleanup dialog appears since narrow face regions, which are not removed by the Repair operation, remain in the wheel rim geometry.
- 2 In the Geometry Cleanup dialog that opens, click Clean up Automatically to automatically clean up the geometry.  
The Remove Details 1 and Cleanup Log nodes are added to the model tree. In the Information section of the Remove Details 1 node you can see that some face regions were collapsed by the operation.
- 3 In the Model Builder, click Mesh 1, and in the Settings change the Element size to Extra coarse.
- 4 Click Build Mesh .

5 To restore the view of the mesh, in the Graphics toolbar, click the Go to Default View  button. The mesh contains approximately 164,000 tetrahedral elements.

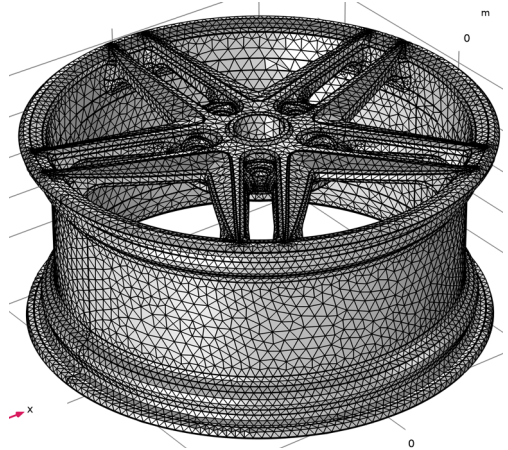

## Removing Small Geometric Entities with the Defeaturing Tools

---

As an alternative to the repair operation described in the previous tutorial you can also apply defeaturing tools to remove small details from the geometry. Using these tools you can first search the geometry for features that fall within a set tolerance, then, after examining the search results, you can decide which ones to delete. While the repair operation has the advantage that it quickly removes every feature it can within a specified tolerance, the defeaturing tools give you more control with selective removal of features. The objects resulting after both of these methods are possible to export to CAD formats, such as IGES, STEP, ACIS®, and Parasolid®.

The defeaturing tools can detect and remove the following type of geometric details:

- small faces
- sliver faces
- short edges
- fillets

When removing small faces, sliver faces, and short edges it is good practice to start by searching for and removing entities that are only slightly larger than the default import tolerance,  $10^{-5}$  m. Thus, in a first attempt, search for small faces with a maximum size of  $10^{-4}$  m. Continue by deleting all or some of the returned small faces, then search again with an even higher tolerance, for example  $5 \cdot 10^{-4}$  m.

The Cleanup Wizard can also serve as a diagnostic tool for locating small features, and can be used in combination with the defeaturing tools. After opening the Cleanup Wizard, you can check the size of some small details to find a good starting point for a tolerance setting for the defeaturing tools.

The step-by-step instructions below guide you through how to defeature the geometry of the wheel rim that appeared in the previous examples.

### Model Wizard

---

- 1 Start COMSOL Multiphysics.
- 2 Select Blank Model to skip the steps of selecting physics interfaces and study type.
- 3 In the Home toolbar, click Add Component  and select 3D.

## Importing the Geometry



---

Before importing the CAD file, make sure that the CAD kernel is used.

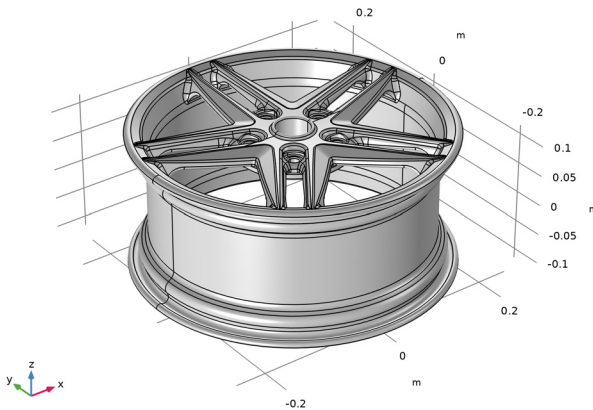
- 1 In the Model Builder window, under Component 1 (comp1) click Geometry 1.
- 2 In the Settings window for Geometry, from the Geometry representation list, choose CAD kernel.
- 3 In the Home toolbar click Import .
- 4 In the Settings window for Import click the Browse button.
- 5 In your COMSOL installation directory navigate to the folder `applications/CAD_Import_Module/Tutorial_Examples` and double-click the file `wheel_rim.x_b`.
- 6 Click Import.



# Finding and Deleting Small Faces

- 1 In the Geometry toolbar, click Defeaturing and Repair  and choose Delete Small Faces  .  
In the Tools window for Delete Small Faces, the wheel rim, imp1, already appears in the Input objects list.
- 2 In the Maximum face size text field enter  $1e-4$ .  
Since the default import tolerance is  $10^{-5}$  m it is good practice to start the search with  $10^{-4}$  m, unless the imported CAD design is of a much larger scale.
- 3 Click the Find Small Faces button.  
Ten faces are listed in the Small face selection list.
- 4 Use the Zoom to Selection  button next to the list to find the faces on the rim, which are found around the bolt holes, as illustrated in the figure below.

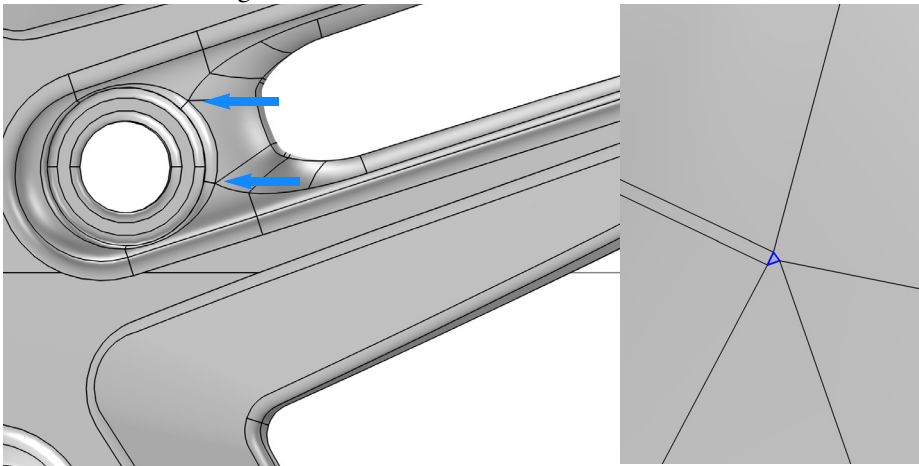
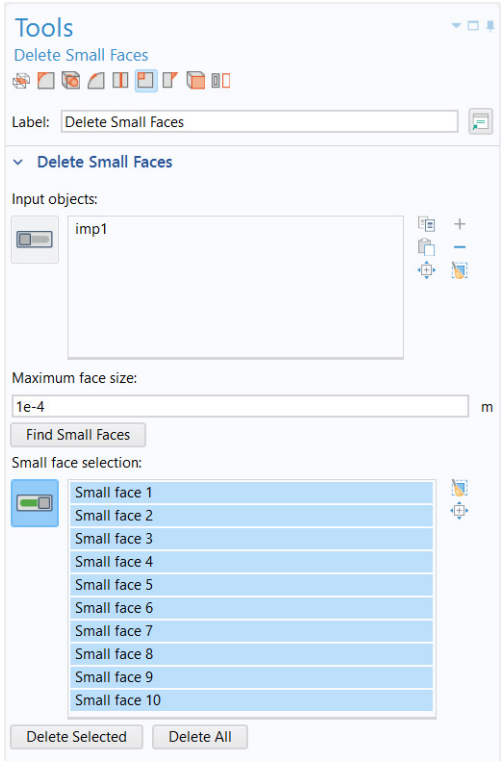

- 5 To delete all faces in the list click the Delete All button.

The tool removes small faces by collapsing them into a vertex (point). Therefore it is not recommended to delete larger faces this way as it might result in unexpected changes to the geometry.

Note that as the operation is done, the Delete Small Faces 1 (dsf1)  node is added to the geometry sequence in the Model Builder tree. The node allows you to go back and edit the delete operation.

The Tools window for Delete Small Faces continues to be displayed so that you can continue defeaturing using this or any of the other defeaturing tools, which you can access by clicking one of the buttons at the top of the window. If you happen to click a node in the geometry sequence of the Model Builder tree, the Settings window for that node will be displayed instead of the Tools window. To bring back the Tools window you can always select one of the defeaturing tools in the Geometry toolbar.

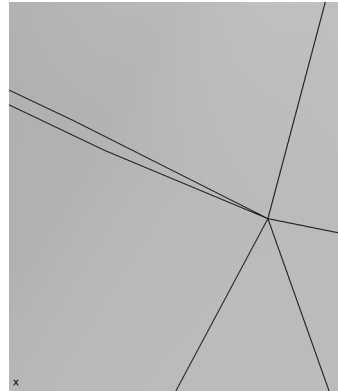

# Finding and Removing Sliver Faces

Slivers are faces with a high aspect ratio, just like the ones next to those small faces you have just deleted.

- 1 From the toolbar on the top of the Tools window, click the Delete Sliver Faces  button.
- 2 Enter  $4e-4$  for the Maximum face width, then click Find Sliver Faces.

A total of 20 faces are found. In addition to the ten slivers around the bolt holes, there are ten more on the spokes. Use the Zoom to Selection  button to find their location on the rim.

- 3 Click the Delete All button.

The tool removes sliver faces by collapsing them into an edge, and in this process it uses the tolerance specified for the search. For best results the tolerance needs to be close to the actual width of the face that is deleted. If it happens that a sliver cannot be deleted you can edit the settings for the operation to set a tolerance that is just slightly larger than the width of the face.

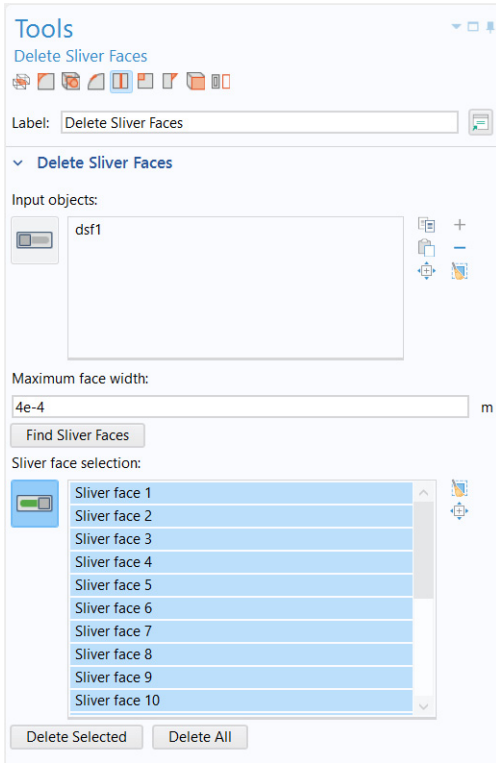

## Finding and Removing Short Edges

- 1 From the toolbar on the top of the Tools window, click Delete Short Edges .
- 2 If not already selected, add the wheel rim to the Input objects list.
- 3 In the Maximum edge length text field enter  $4e-4$ .
- 4 Click the Find Short Edges button.

It seems that the previous operations have removed all edges that were shorter than this value.

- 5 Increase the Maximum edge length to  $9e-4$ , then click the Find Short Edges button again. Take some time to find the edges in the list on the geometry and measure their length. They reoccur in similar places on each spoke. Some of the locations are indicated in the figure to the right.

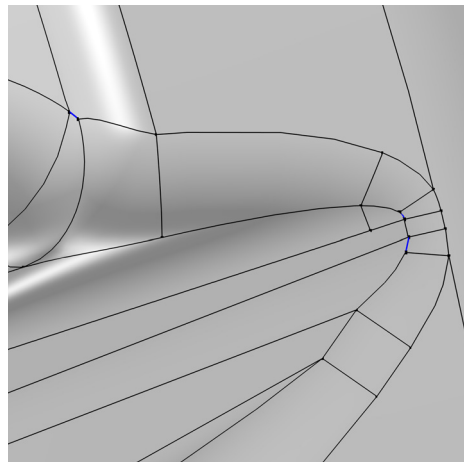
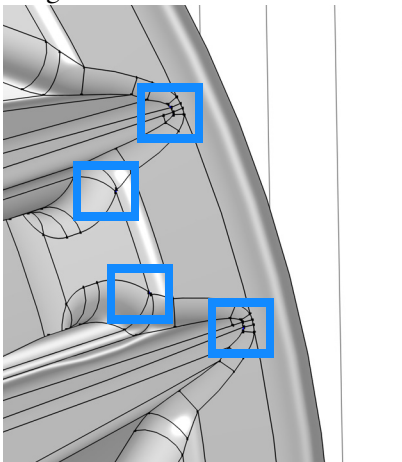
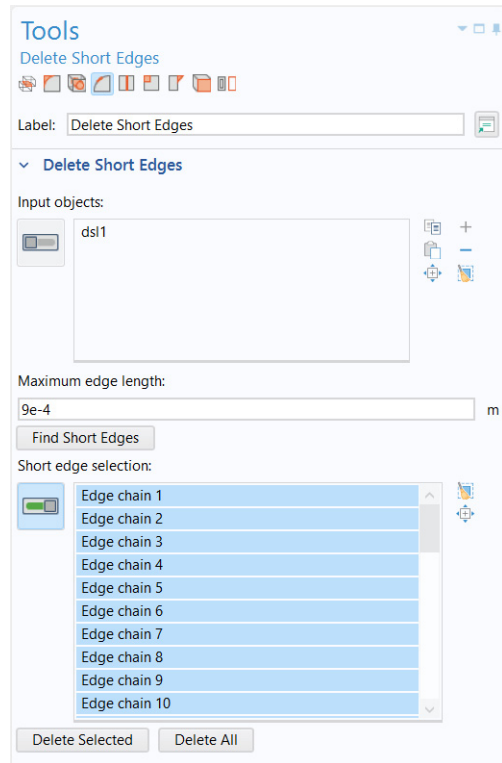

6 Click the Delete All button.

In the resulting geometry all short edges have been collapsed to vertices. The wheel rim geometry is now similar to the one after the last repair operation in the tutorial *Removing Small Geometric Entities with Repair*. The difference is that by using the defeaturing tools you can have more control over which entities to delete and in which order.

Just as for the Repair operation, it is recommended to use these tools with small tolerances to avoid large modifications to the geometry.

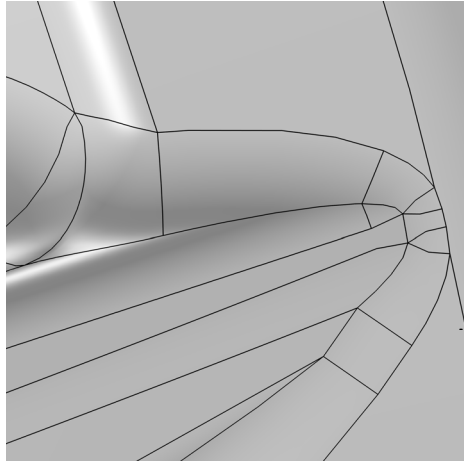

## Finding and Deleting Fillets

In the previous tutorial, *Removing Small Geometric Entities with Repair*, we left the wheel rim geometry with narrow face regions remaining on a face. Here you will delete fillets adjacent to some of the narrow face regions to thereby make the face wider.

- 1 From the toolbar on the top of the Tools window, click the Delete Fillets  button.
- 2 If not already selected, add the wheel rim to the Input objects list.
- 3 In the Maximum fillet radius text field enter 2 [mm].
- 4 Click the Find Fillets button.

Twenty fillets with a radius smaller than 2 mm are found. Remove only the fillets around the cavities on the back of the wheel rim. These are highlighted in the figure further below.

- 5 First, click Clear Selection  next to the Fillet Selection list.
- 6 Select Fillet 16 to 20 from the list, or, in the Graphics window, select a face each from the fillets highlighted in the image to the right.
- 7 Click the Delete Selected button.

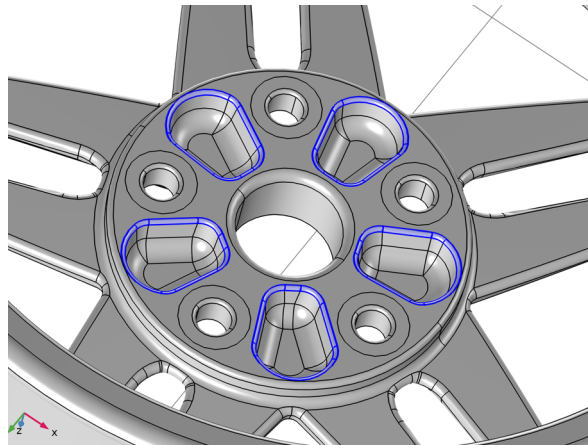
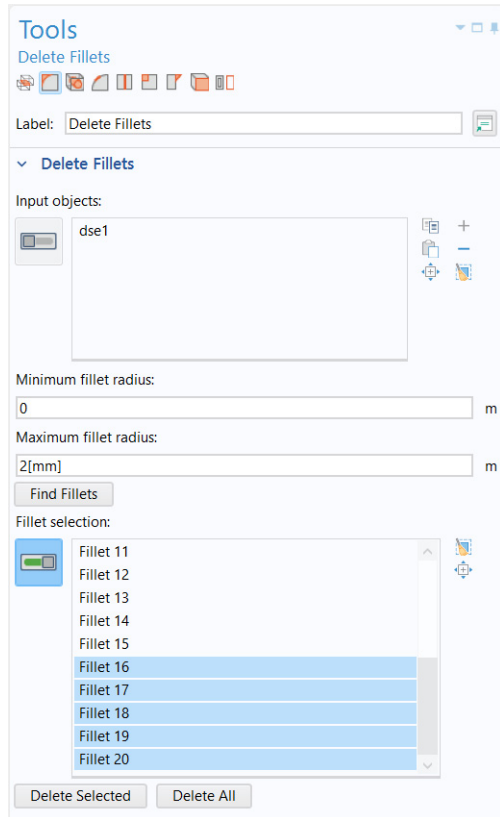

## Generating a Tetrahedral Mesh

---

As a final step generate the default tetrahedral mesh for the wheel rim.

1 In the Model Builder window, under Component 1 click Mesh 1.

Remaining narrow face regions are detected by the Geometry Cleanup.

2 In the Geometry Cleanup dialog that opens, click Clean up Automatically to automatically clean up the geometry.

The remaining narrow face regions are collapsed by the Remove Details 1 node added by the cleanup.

3 In the Model Builder, click Mesh 1 and change the Element size to Extra coarse.

4 Click Build Mesh .

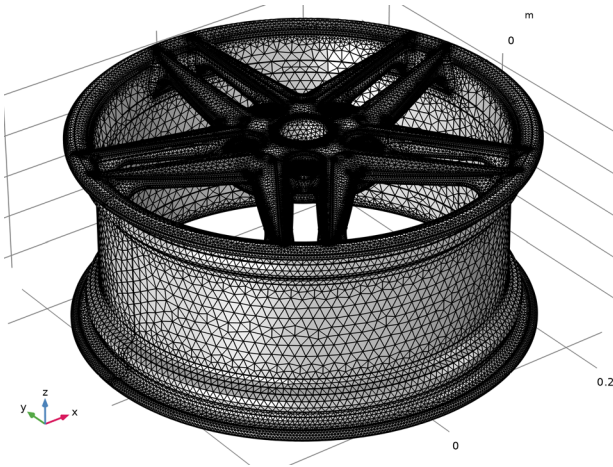

The generated mesh consists of approximately 152,000 elements and there should be no Information nodes appearing under the Mesh 1 node due to small geometric entities.

# Creating Modeling Domains Around an Imported Geometry

---

The majority of 3D CAD files include only the geometry of the product to be manufactured. For finite element analysis, however, you find yourself often in a situation where additional geometry is needed, for example, to analyze the flow inside or outside a device. The example in this section, involving the geometry for a loudspeaker enclosure, demonstrates how to create domains inside and outside an imported CAD assembly. The following steps are covered:

- Importing a STEP file
- Finding and deleting holes and other details from the geometry
- Creating the union of all imported objects needed to generate a domain inside the objects
- Using the Cap Faces operation to create a domain inside the enclosure
- Creating a domain that surrounds the imported enclosure.

## Model Wizard

---

- 1 Start COMSOL Multiphysics.
- 2 Select Blank Model to skip the steps of selecting physics interfaces and study type.
- 3 In the Home toolbar, click Add Component  and select 3D.

## Importing the Geometry

---

Before importing the CAD file, make sure that the CAD kernel is used.

- 1 In the Model Builder window, under Component 1 (comp1) click Geometry 1.
- 2 In the Settings window for Geometry, from the Geometry representation list, choose CAD kernel.
- 3 In the Home toolbar, click Import .
- 4 In the Settings window for Import click the Browse button.
- 5 In your COMSOL installation directory navigate to the folder `applications/CAD_Import_Module/Tutorial_Examples` and double click the file `loudspeaker_enclosure.step`.

- 6 From the Length unit list choose From CAD document.
- 7 Click Import.

As soon as the import is done the geometry appears in the Graphics window.

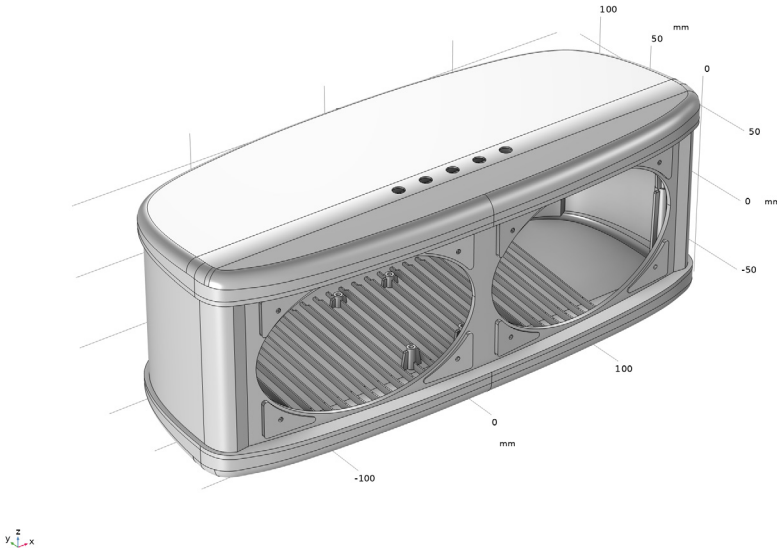

The enclosure consists of four solid objects.

## Opening the Selection List Window

---

When working with imported CAD assemblies it is helpful to view a list of the imported objects. You can do this in the Selection List window.

- 1 In the Geometry toolbar, click  Selection List.
- 2 In the Selection List window that appears, click through the listed objects to identify each component.

The name of an imported object is derived from the tag of the import feature and the name of the object from the imported CAD file, or a number when the file does not contain any names. The list also indicates the object type, which can be solid (objects with an interior volume), surface, or mixed. The lower

section of the window that lists named selections is empty as there are no named selections in the model.



Three of the four imported solid objects represent the top, bottom, and mid sections of the speaker enclosure, with an additional object in the back that contains the holes for the connections.

## Deleting Holes

---

To create a domain inside the enclosure we need the imported objects to form a watertight structure. A first step in achieving this is to apply the Delete Holes operation that can find and delete cylindrical holes in solid objects.

**Note:** A geometry object that contains more than one domain is a nonmanifold object for which defeaturing operations, such as deleting holes, are not supported. Thus it is recommended to use the defeaturing tools before computing the union of the imported objects.

- 1 In the Geometry toolbar, click  Defeaturing and Repair and choose  Delete Holes.
  - 2 In the Tools window all objects already appear in the Input objects list, and you can enter 6[mm] in the Maximum hole radius text field.
  - 3 Click Find Holes.
- The tool found 36 holes, which appear in the Hole selection list, and they are also highlighted on the geometry.

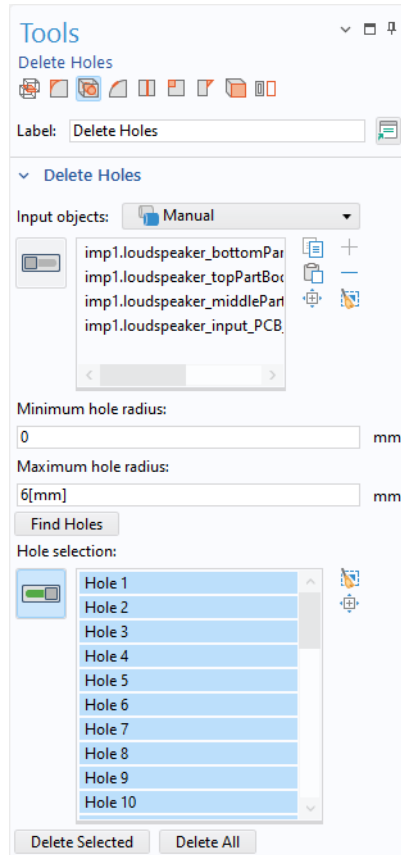

4 Click Delete All to remove all holes.

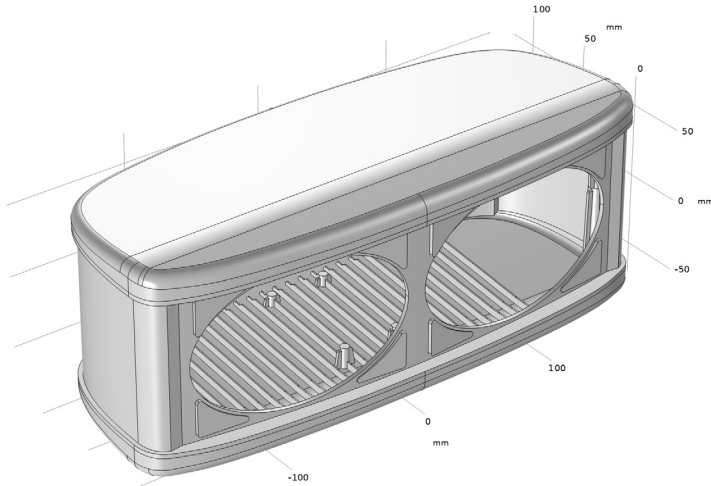



The holes are now deleted, and a Delete Holes 1 (dho1) node is inserted into the geometry sequence.

## Deleting Details

---



The holes that now remain in the back of the enclosure for the connections do not have a cylindrical cross section. You can delete them using the Replace Faces tool, which is suitable for deleting various geometric details that may not be important for a simulation. In addition to the holes for the connections, use this tool to delete some of the mounting details from the bottom part of the enclosure.

5 Click the  Select Objects button in the Graphics toolbar.

6 Click the  Click and Hide button in the Graphics toolbar.

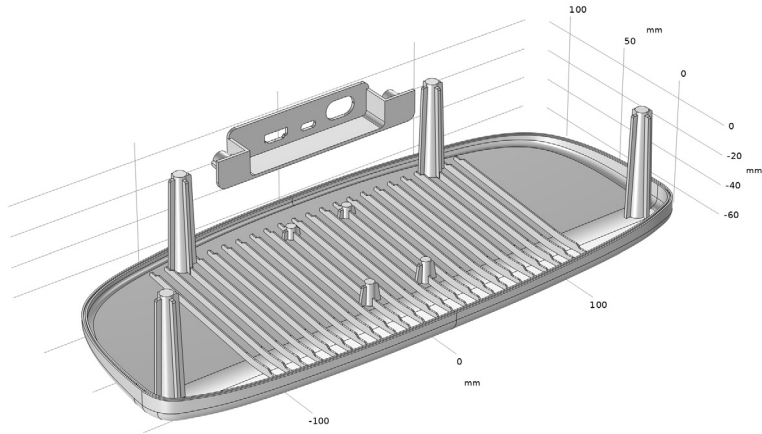
- 7 In the Graphics window select the objects for the enclosure mid and top sections (dh01 (2) and dh01 (3)) to hide them from view.



- 8 Click again the  Click and Hide button in the Graphics toolbar to turn off the click and hide mode.
- 9 Click the  Zoom Box button in the Graphics toolbar and zoom in to the holes in the back.

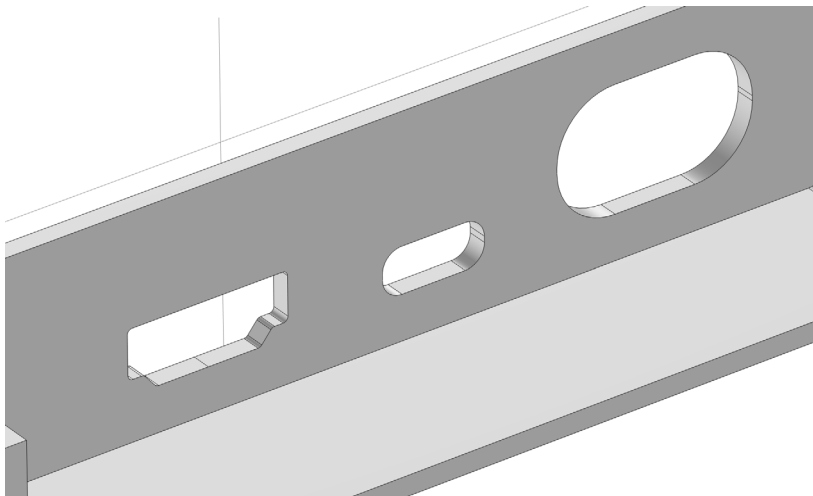

**10** In the Tools window for Delete Holes, click  Replace Faces.

Using this tool you can delete larger geometric details, and the resulting gap is automatically healed by one of two methods: the surrounding faces are grown or shrunken to cover the gap; a new face is constructed based on the edges of the gap.

Add the boundaries of the holes to the Faces to replace list in the Tools window for Replace Faces. The easiest to do this is as follows.

**11** Click the  Select Box button in the Graphics toolbar.

**12** Hold the left mouse button to draw a square around the holes to select their faces.

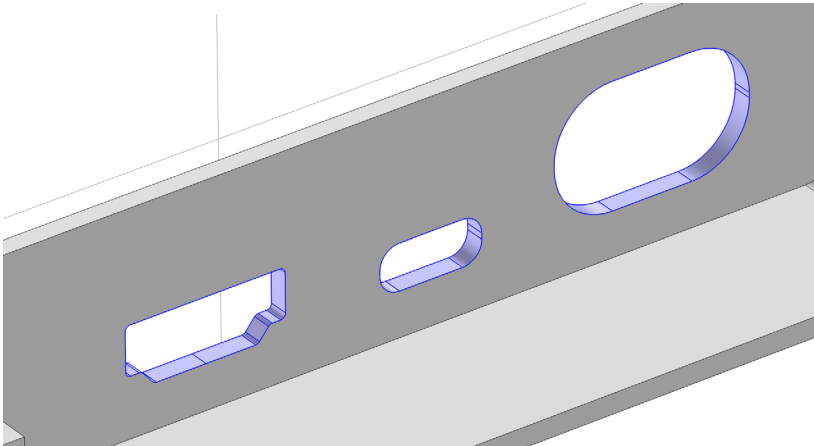



**13** In the Tools window for Replace Faces, select the Heal as through hole checkbox.

**14** In the Tools window for Replace Faces, click Replace Selected.

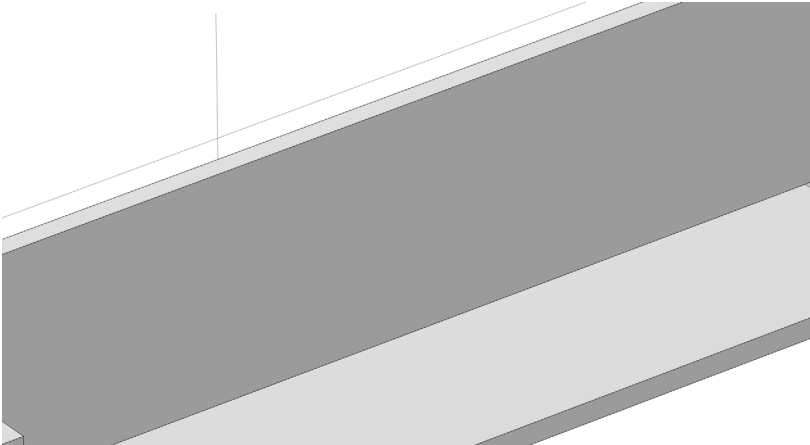
The holes are removed and the surrounding boundaries are extended to cover the gap.



**15** Click the  Zoom Extends button in the Graphics toolbar.

**16** Click the  Go to XY View button in the Graphics toolbar.

**17** Click the  Zoom Box button in the Graphics toolbar and zoom in to the two mounting details in the front.

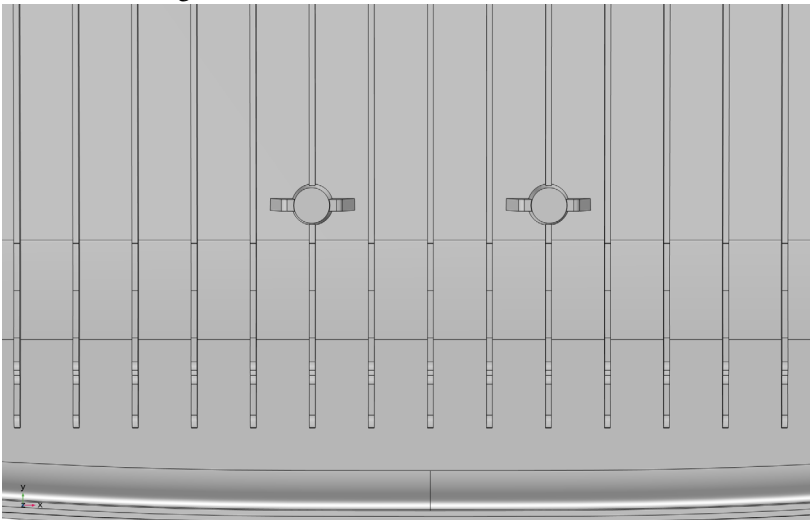

**18** Click the  Select Box button in the Graphics toolbar.

19 Hold the left mouse button to draw a square around the faces highlighted below.

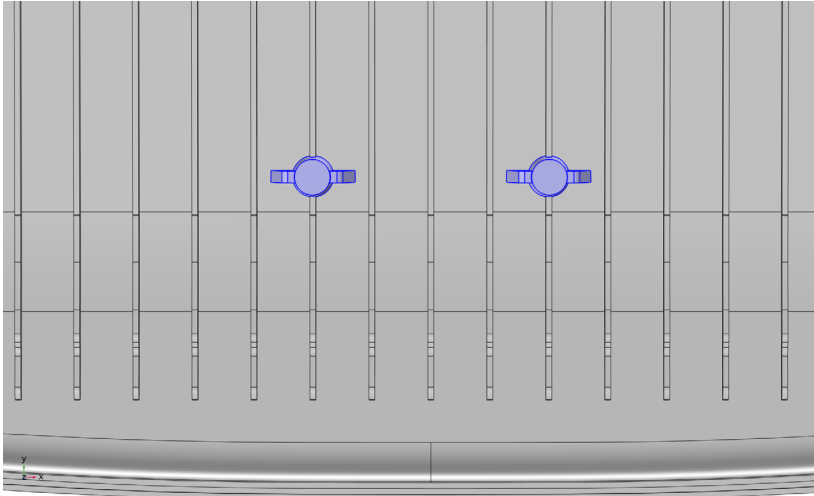



20 In the Tools window for Replace Faces, clear the Heal as through hole checkbox.

21 In the Tools window for Replace Faces, click Replace Selected.

22 Click the  Go to Default View button in the Graphics toolbar.

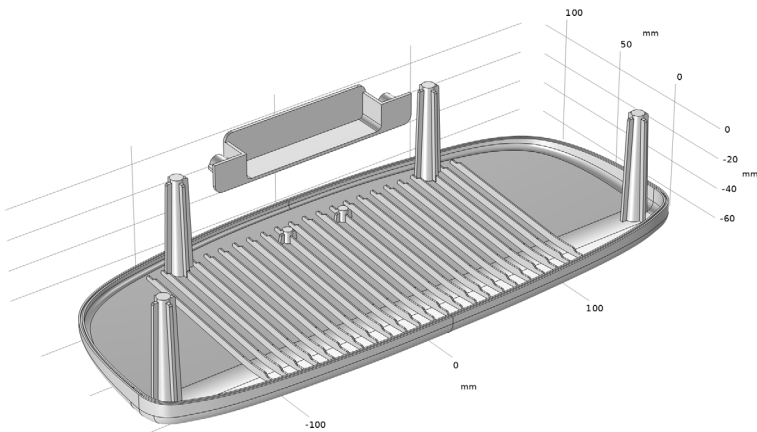
The two mounting details are removed from the geometry.



- 23 Click the  Reset Hiding button in the Graphics toolbar, and in the Confirm Delete dialog that opens click Delete all hide for geometry nodes.

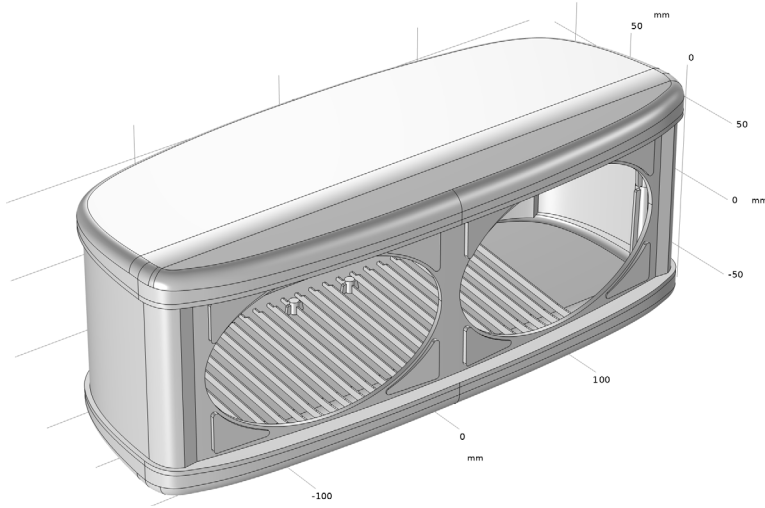

## Creating the Union of All Objects

---

To create faces that cover the openings for the speaker elements use the Cap Faces operation, which can also generate a solid domain inside the enclosure if the created faces result in a new closed volume. To make sure that this is the case you will now create the union of all imported objects.

- 1 In the Geometry toolbar, click  Booleans and Partitions and choose Union.
- 2 In the Settings window for Union, from the Input objects list, choose All objects.
- 3 Clear the Keep interior boundaries checkbox.

With this checkbox cleared the object resulting from the union will have a single domain. If you instead would keep the interior boundaries, the resulting object would have several domains corresponding to the different parts of the enclosure and any intersections between these. This can be useful for assigning different material properties for the different parts.

- 4 In the Settings window for Union, click  Build Selected.  
Examine this new geometry object using the Measure tool.
- 5 Right-click Geometry 1 and choose Measure.

6 Select the object uni1 in the Graphics window.

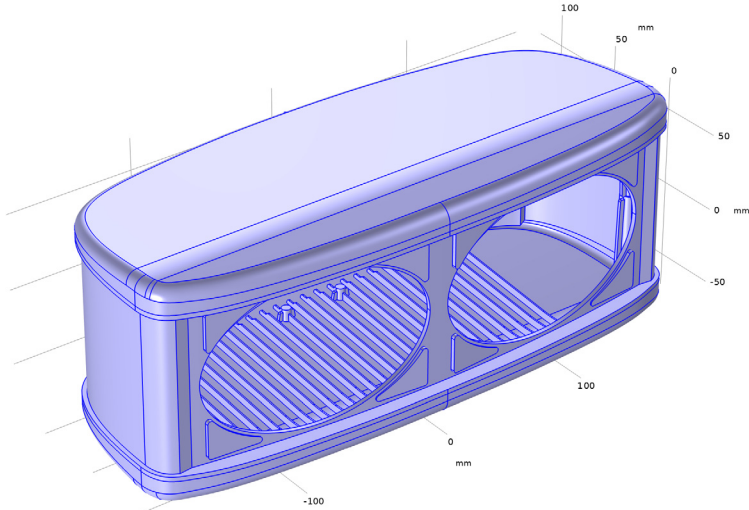

According to the information displayed in the Measure window the object uni1 contains 1 domain and 1400 faces.

## Creating an Explicit Selection



---

The Cap Faces operation, which you will use to create a domain inside the enclosure, needs an input in form of the bounding edges of the empty volume that

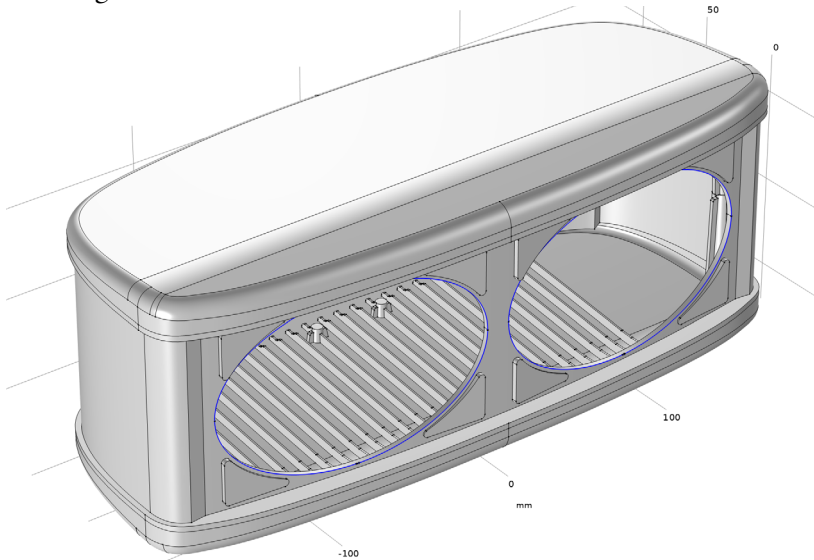
should be turned into a solid. For this geometry these are the edges highlighted in the figure below.



You could select these edges directly in the Cap Faces operation, however a more efficient way, which only requires the selection of one segment from each edge loop, is to use an Explicit Selection where you have the option to automatically include continuous edges in the selection.

- 1 In the Geometry toolbar click Selections  and choose Explicit Selection .
- 2 In the Settings window for Explicit Selection select Edge from the Geometric entity level list.
- 3 Also select the Group by continuous tangent checkbox.
- 4 From the Graphics window select one edge each from the two edge loops highlighted in the figure above. Continuous edges are automatically added to the selection. When done check that all edges are highlighted.
- 5 Switch to the Selection List window, or open it again, to check that Explicit Selection 1 now appears under Edge Selections.

## Creating a Domain with Cap Faces

---

At this time the geometry is ready for creating the inside domain.

- 1 In the Geometry toolbar, click  Defeaturing and Repair and choose Cap Faces.

The bounding edges of the empty volume inside the manifold are included in Explicit Selection 1 (sel1).

- 2 In the Settings window for Cap Faces, from the Bounding Edges list choose Explicit Selection 1.

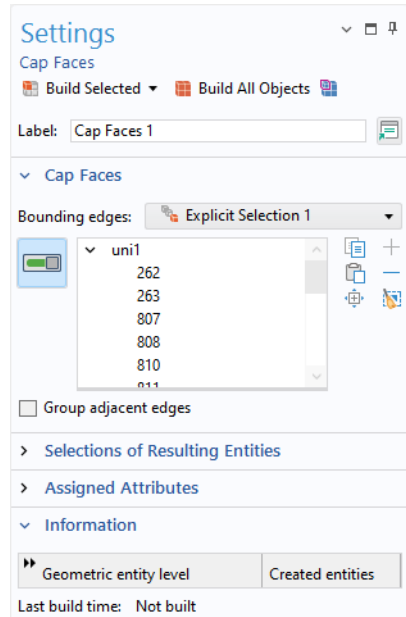

3 Click  Build Selected to complete the operation.

The operation closed off the two openings with new faces, and also created a solid domain where it used to be a void inside the enclosure.

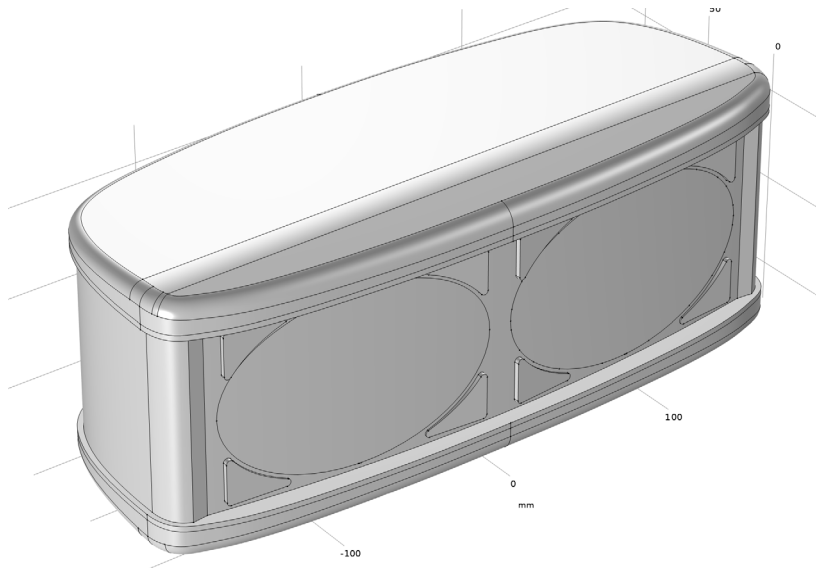

According to the Information section of the Settings window for Cap Faces,

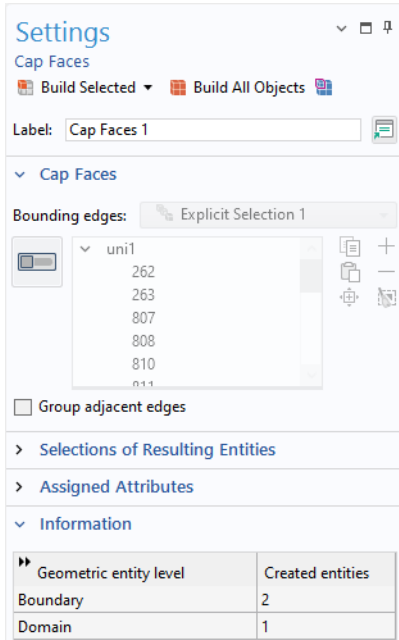

2 boundaries and 1 domain were created.





## Creating a Surrounding Domain

---

To create a domain that surrounds the enclosure add a sphere to the geometry and set it up as a bounding ball for the geometry.

- 1 In the Geometry toolbar, click  Sphere.
- 2 In the Settings window for Sphere, locate the Definition section, and from the Defined by list, choose Bounding ball (approximate).
- 3 Select the enclosure object (cap1) in the Graphics window.
- 4 In the Margin text field, type 150 [mm].
- 5 Click  Build Selected to create the sphere.

- 6 Click first the  Zoom Extents button, followed by the  Transparency button in the Graphics toolbar.

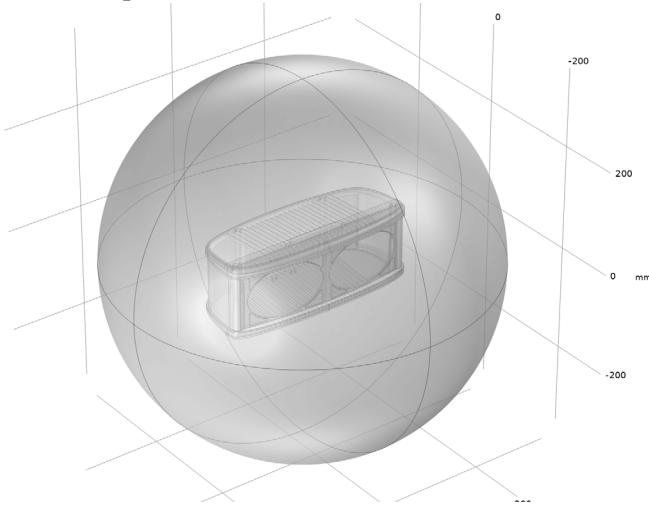

**Note:** The objects for the sphere and the enclosure are united by the Form Union (fin) node, which is built automatically when you leave the geometry branch of the model tree. Form Union results in three domains: the enclosure, and the volumes on the inside and outside of the enclosure.

## Geometry Cleanup and Meshing

---

When leaving the geometry branch of the model tree, the geometry is automatically analyzed for small details.

- 1 In the Model Builder window, under Component 1 click Mesh 1.
- 2 In the Geometry Cleanup dialog that opens, click Clean Up Automatically to detect and remove small details from the geometry before meshing.

As the cleanup is completed the Cleanup Log appears indicating that all detected issues were resolved. According to the information in the Settings window, a Remove Details feature was added and 47 vertices and 45 edges were deleted in the process.

- 3 In the Model Builder window, under Component 1 (comp1) click Mesh 1.

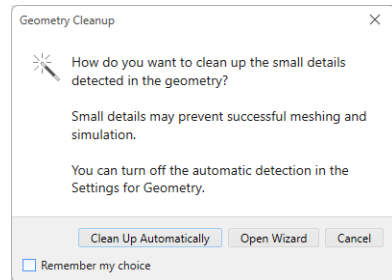

4 In the Settings window for Mesh, click  Build All.

