



Add-in created in COMSOL Multiphysics 6.4

# Discrete Fracture Network – 3D

## Introduction

Modeling discrete fracture networks (DFN) helps to understand the characteristics of flow, transport, and mechanics in fractured rocks and reservoirs. Therefore, it is often used for geotechnical and hydrological applications.

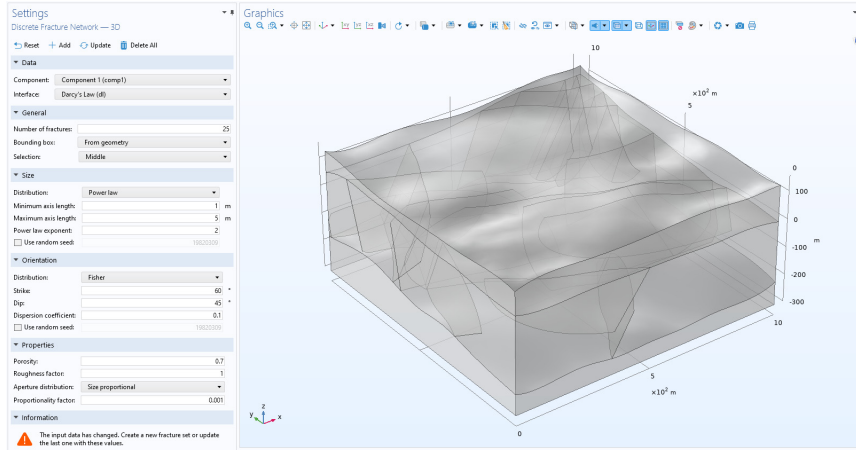

With this add-in you can create a DFN based on various distribution functions for size, orientation, and aperture. You can either use the add-in for adding a DFN to your 3D model or start with the add-in to create a completely new model.

When creating a DFN, a new 3D part geometry is created. The fractures are ellipses and their size, position, and orientation are determined by the specified settings. This part then is imported into the geometry of the selected component or a new component and geometry will be created.

The add-in also creates a Fracture feature following a cubic law in a new or existing Darcy's Law interface. The values for the aperture are defined as variables under a variable group node.

The following distributions and distribution functions are available:

### *Uniform Random*

The probability density function for the variable  $x$  is given by

$$f(x) = \begin{cases} \frac{1}{x_{\max} - x_{\min}} & \text{for } x_{\min} \leq x \leq x_{\max} \\ 0 & \text{else} \end{cases} \quad (1)$$

### Power Law

The probability density function for the variable  $x$  is

$$f(x) = \frac{\alpha - 1}{x_{\min}} \left( \frac{x}{x_{\min}} \right)^{-\alpha} \quad (2)$$

### Fisher (Orientation Only)

The probability density function for the Fisher distribution describes the angular deviation  $\theta$  (SI unit: rad) from the mean angle of the orientation of the ellipse:

$$f(\theta) = K \frac{\sin \theta e^{K \cos \theta}}{e^K - e^{-K}} \quad (3)$$

Here,  $K$  is the dispersion coefficient or Fisher constant.

### Size Proportional (Aperture Only)

The aperture  $a$  (SI unit: m) is proportional to the length  $l$  of the fracture

$$a = cl \quad (4)$$

with the proportionality factor  $c$ .

After adding a DFN you can modify the settings. The more complex the DFN becomes, the more likely it is that manual modifications of the geometry and/or the mesh are necessary, because the statistical distribution can lead to small details in the geometry. You can address them by either modifying the geometry or creating a manual mesh that first meshes the fracture sets with a triangular mesh before meshing the remaining geometry.

Using the CAD kernel is recommended for modeling complex 3D fracture networks, because the resulting geometry will be more robust.

### Reference

---

I. B. Berkowitz, “Characterizing flow and transport in fractured geological media: A review,” *Advances in Water Resources*, vol. 25, pp. 861–884, 2002.

---

**Add-in Library path:** Porous\_Media\_Flow\_Module/  
discrete\_fracture\_network\_3d

---

When you load the add-in into your model it automatically detects 3D components and Darcy's Law interfaces to which a DFN could be added

### TOOLBAR

Use the toolbar at the top of the Settings window for different actions.



**Reset** resets all values to factory settings. With **Add** a DFN with the current settings is added to the selected component and interface. **Update** allows to update the last created DFN with the new settings. **Delete All** deletes all DFN in the model and related features but does not delete any components or interfaces.

### DATA

You can select between creating a new component and Darcy's Law interface or select between existing ones in your model.



### GENERAL

This determines the overall size of the DFN. Enter the **Number of Fractures**. The total number is limited to 200 for a single fracture set. If you want to create a DFN with more than 200 fractures you can add multiple fracture sets instead.

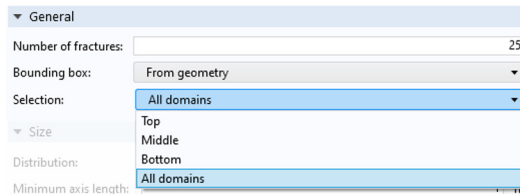

When a geometry is present you can switch between **From geometry** and **Manual** in the **Bounding box** list. If **From geometry** is selected, a **Selection** list appears. This list will be populated with all available domain selections that are defined under the geometry node and the default is **All domains**. Depending on these settings the bounding box is determined either by the size and position of the whole geometry or the chosen selection.

This determines the total size and position of the DFN and all fractures are created inside this bounding box. If you want to define the bounding box differently or if no geometry is present enter the values for the size and lower left corner of the bounding box.

## SIZE

Select between different distribution functions for the size of the fractures. The position of the fractures always follows a uniform random distribution function ([Equation 1](#)).

▼ Size

Distribution: Power law

Minimum axis length:  m

Maximum axis length:  m

Power law exponent:

Use random seed:

From the **Size distribution** list, select **Constant** to specify the **Axis length** and **Eccentricity**. All fractures have the same size. Select **Uniform random** and specify the **Minimum axis length** and **Maximum axis length**. The size is randomly distributed to each fracture ([Equation 1](#)). The eccentricity is a random value between 0.1 and 1. Select **Power law** (default) and specify the **Minimum axis length**, **Maximum axis length**, and the **Power law exponent**. The size distribution then follows a power-law distribution function ([Equation 2](#)).

To be able to create reproducible DFN select the **Use random seed** checkbox and enter an integer.

## ORIENTATION

Select between different distribution functions.

▼ Orientation

Distribution: Fisher

Strike:  °

Dip:  °

Dispersion coefficient:

Use random seed:

From the **Orientation distribution** list, select **Constant** to specify a constant **Strike** and **Dip** angle. The strike direction is the main axis direction defined by the angle to the  $x$ -axis in the  $xy$ -plane. The dip direction is then the vertical angle to this plane ([Figure 1](#)). Select **Uniform random** to get a random orientation distribution for all fractures ([Equation 1](#)). Select **Fisher** to specify a mean **Strike** and **Dip** angle and the **Dispersion coefficient**.

The orientation distribution then follows a fisher distribution around the specified strike and dip angle.

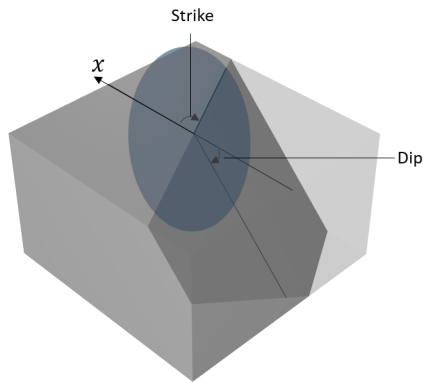

Figure 1: Strike and dip directions.

To be able to create reproducible DFN select the **Use random seed** checkbox and enter an integer.

## PROPERTIES

In this section you specify the hydraulic properties of the fracture network. Specify **Porosity** and **Roughness factor** and select an **Aperture distribution**.

▼ Properties	
Porosity:	<input type="text" value="0.7"/>
Roughness factor:	<input type="text" value="1"/>
Aperture distribution:	<input type="button" value="Size proportional"/>
Proportionality factor:	<input type="text" value="0.001"/>

Select **Constant** to assign a constant **Aperture** to all fractures. Select **Uniform random** and specify a **Minimum aperture** and **Maximum aperture**. The aperture is then randomly distributed to each fracture (Equation 1). Select **Size proportional** (default) and specify a **Proportionality factor**. The aperture is then proportional to the size of each fracture (Equation 4). Select **Power law** and specify a **Minimum aperture** and **Maximum aperture** and a **Power law exponent**. The aperture distribution then follows a power law distribution function (Equation 2).

To be able to create reproducible DFN select the **Use random seed** checkbox and enter an integer.

**INFORMATION**

This section provides status information. It recommends to use the CAD kernel if this is not set already in the geometry node.