

INTRODUCTION TO Acoustics Module

Introduction to the Acoustics Module

© 1998–2025 COMSOL

Protected by patents listed on www.comsol.com/patents, or see Help > About COMSOL Multiphysics on the File menu in the COMSOL Desktop for less detailed lists of U.S. Patents that may apply. Patents pending.

This Documentation and the Programs described herein are furnished under the COMSOL Software License Agreement (www.comsol.com/sla) and may be used or copied only under the terms of the license agreement.

COMSOL, the COMSOL logo, COMSOL Multiphysics, COMSOL Desktop, COMSOL Compiler, COMSOL Server, and LiveLink are either registered trademarks or trademarks of COMSOL AB. All other trademarks are the property of their respective owners, and COMSOL AB and its subsidiaries and products are not affiliated with, endorsed by, sponsored by, or supported by those trademark owners. For a list of such trademark owners, see www.comsol.com/trademarks.

Version: COMSOL 6.4

Contact Information

Visit the Contact COMSOL page at www.comsol.com/contact to submit general inquiries or search for an address and phone number. You can also visit the Worldwide Sales Offices page at www.comsol.com/contact/offices for address and contact information.

If you need to contact Support, an online request form is located on the COMSOL Access page at www.comsol.com/support/case. Useful links:

- Support Center: www.comsol.com/support
- Product Download: www.comsol.com/product-download
- Product Updates: www.comsol.com/product-update
- COMSOL Blog: www.comsol.com/blogs
- Discussion Forum: www.comsol.com/forum
- Events: www.comsol.com/events
- COMSOL Video Gallery: www.comsol.com/videos
- Support Knowledge Base: www.comsol.com/support/knowledgebase
- Learning Center: www.comsol.com/support/learning-center

Part number: CM020204

Contents

Introduction	5
The Acoustics Module Physics Interfaces	9
Physics Interface Guide by Space Dimension and Study Type	17
The Application Libraries Window	25
Basics of Acoustics.	26
Governing Equations	26
Numerical Methods	27
Length and Time Scales.	28
Boundary Conditions	29
Elastic Waves.	29
Models with Losses.	30
Geometrical Acoustics.	30
Example: Absorptive Muffler	32
Model Definition.	32
Domain Equations	32
Boundary Conditions	34
Results and Discussion	34
References.	38
Additional Examples from the Application Libraries	68
Eigenmodes in a Muffler.	68
Piezoacoustic Transducer.	69
Loudspeaker Driver in a Vented Enclosure.	69
The Brüel & Kjør 4134 Condenser Microphone	70

Introduction

The Acoustics Module consists of a set of physics interfaces that enable you to simulate the propagation of sound in fluids and solids in a fully multiphysics-enabled environment. The available physics interfaces include pressure acoustics, elastic waves, acoustic–solid interaction, aeroacoustics (detailed convected acoustic models and flow induced noise), thermoviscous acoustics, ultrasound, geometrical acoustics, and pipe acoustics. For acoustic analysis, covering the frequency range from infrasound to ultrasonics as well as many formulations of the underlying equations, the Acoustics Module incorporates four numerical methods, including finite elements (FEM), boundary elements (BEM), discontinuous Galerkin (dG-FEM), and ray tracing.

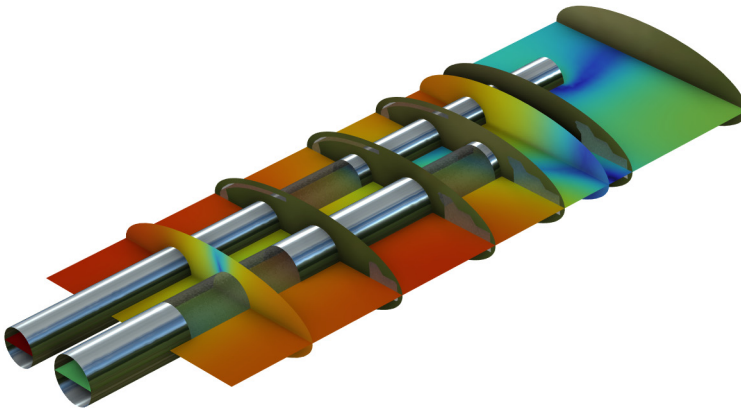

Figure 1: COMSOL model of the sound pressure level distribution in a muffler system.

Acoustic simulations using this module can easily solve classical problems such as scattering, diffraction, emission, radiation, and transmission of sound. These problems are relevant to muffler design, loudspeaker construction, sound insulation for absorbers and diffusers, the evaluation of directional acoustic patterns like directivity, noise radiation problems, and much more. The acoustic–structure multiphysics couplings enable modeling vibroacoustic problems involving structure- and fluid-borne sound and their interaction. For example, acoustic–structure interaction is simulated for detailed muffler design, ultrasound piezo-actuators, sonar technology, and noise and vibration analysis of machinery in the automotive industry. Using the capabilities of COMSOL Multiphysics, it is also possible to analyze and design electroacoustic transducers such as loudspeakers, sensors, microphones, and hearing aid receivers. The propagation of

elastic waves can be modeled in solids and porous materials as well as in coupled problems.

Aeroacoustic problems can be analyzed and modeled by solving the linearized potential flow equations, the linearized Euler equations, or the linearized Navier–Stokes equations. These equations are used to model the one-way interaction between an external flow and an acoustic field, so-called convected acoustics. Applications range from jet-engine noise analysis to simulating acoustic flow sensors, liner systems with bias and/or grazing flow, and mufflers with flow. Flow-induced noise can be modeled using the Lighthill acoustic analogy or the aeroacoustic wave equation. This analysis requires a detailed LES or DES flow analysis available with the CFD Module. Flow data available in the CGNS format can be imported and mapped.

The Thermoviscous Acoustics interfaces can accurately model systems having small geometrical dimensions where thermal and viscous boundary layer losses are important. This is relevant to the mobile phone and hearing aid industries, for all transducer designers, and for modeling the true properties of metamaterials. For MEMS transducers, a slip-wall formulation can be added. In the time domain, nonlinear effects can also be included.

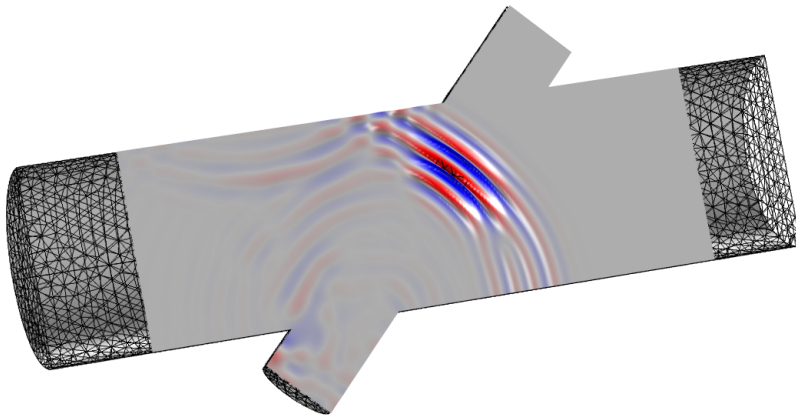

Figure 2: COMSOL model of an ultrasound flowmeter modeled using the Convected Wave Equation interface. The model includes interaction with a steady state background flow.

The Ultrasound branch includes two interfaces. The Convected Wave Equation, Time Explicit interface can be used to compute the transient propagation of linear ultrasound acoustic waves over large distances (relative to the wavelengths). The Nonlinear Pressure Acoustics, Time Explicit interface can be used to model the propagation of high amplitude nonlinear acoustic waves. Both interfaces can be coupled to the Elastic Waves, Time Explicit interface and the Piezoelectric Waves, Time Explicit multiphysics interface. The interfaces under the ultrasound branch

are not restricted to high-frequency propagation but can, in general, be applied to any acoustically large problem.

Geometrical Acoustics includes the Ray Acoustics and the Acoustic Diffusion Equation interfaces. These physics interfaces are valid in the high-frequency limit where the acoustic wavelength is much smaller than the characteristic geometric features. Both interfaces are suited for modeling acoustics in rooms and concert halls. The Ray Acoustics interface can also be used, for example, in outdoor scenarios.

Dedicated functionality also exists for modeling the steady fluid flow, called Acoustic Streaming, induced by an acoustic field. Acoustic streaming is a nonlinear phenomenon that occurs due to the nonlinearity of the Navier–Stokes equations. Applications are in the biomedical industry such as lab-on-a-chip for cell sorting and more.

The Acoustics Module is of great benefit to engineers. By using 3D simulations, existing products can be optimized and new products more quickly designed with virtual prototypes. Simulations also help designers, researchers, and engineers to gain insight into problems that are difficult to handle experimentally. Also, by optimizing a design virtually before real-life testing and manufacturing it, companies save time and money.

Some of the physics interfaces available with this module are shown in [Figure 3](#) and are located under the Acoustics branch in the Model Wizard when selecting physics. The next section [The Acoustics Module Physics Interfaces](#) provides an overview of the physics interface functionality under each branch.

There are many application areas where these physics interfaces are used — from modeling simple pressure waves in air to examining complex interactions between elastic waves and pressure waves in porous materials. For a brief introduction to the basic concepts and theory of acoustics, see the [Basics of Acoustics](#).

The Acoustics Module Application Library has many examples of applications modeling, for example sound-insulation lining, loudspeakers, microphones, and mufflers. These examples show, among other things, how to simulate acoustic losses. The loss models range from homogenized empirical fluid models for fibrous materials to those that include thermal and viscous losses in detail using the Thermoviscous Acoustics interface.

Predefined couplings can be used to model the interaction between acoustic, structural, and electric fields in piezoelectric materials (see [The Application Libraries Window](#) for information about accessing these files). You can also get started with your own COMSOL modeling by going to the tutorial [Example: Absorptive Muffler](#).

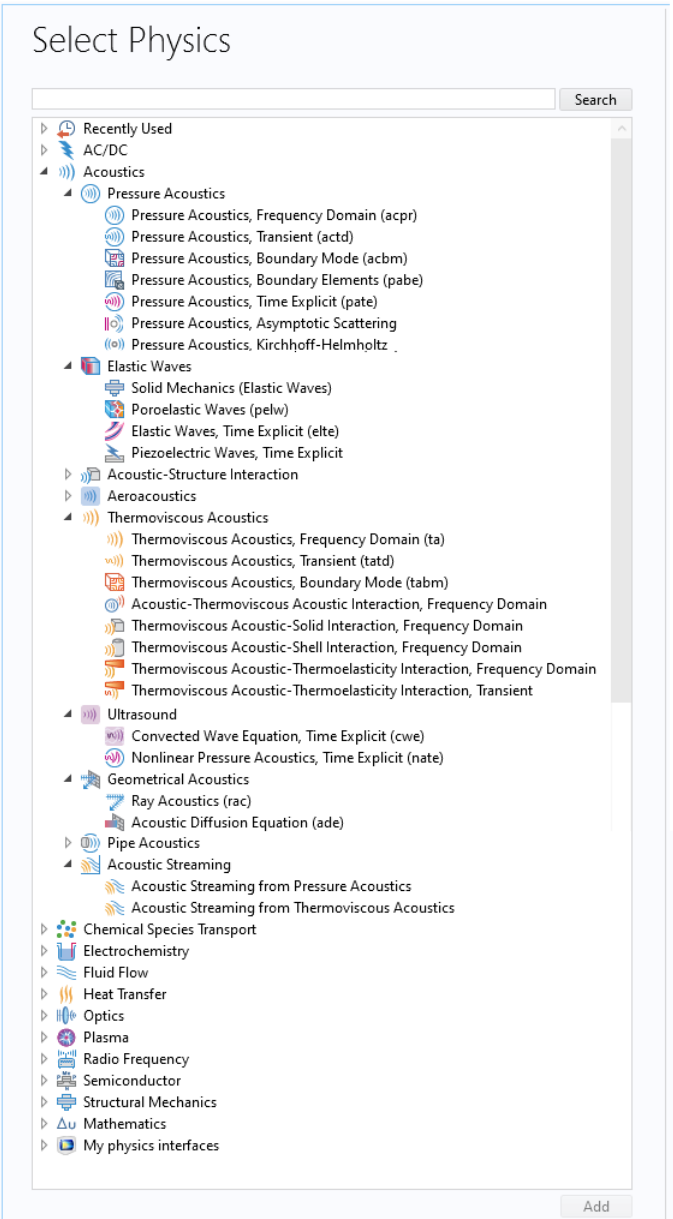

Figure 3: The Acoustics Module physics interfaces and branches in the Select Physics wizard. Some physics interfaces require additional modules.

The Acoustics Module Physics Interfaces

There are nine main branches — Pressure Acoustics, Elastic Waves, Acoustic–Structure Interaction, Aeroacoustics, Thermoviscous Acoustics, Ultrasound, Geometrical Acoustics, Pipe Acoustics, and Acoustic Streaming — and each of the physics interfaces is briefly described here, followed by the [Physics Interface Guide by Space Dimension and Study Type](#) listing the physics interface availability by space dimension and preset study types.

PRESSURE ACOUSTICS

The Pressure Acoustics branch (🔊) has interfaces where the sound field is described by the pressure p . The physics interface solves acoustic problems in the frequency domain using the Pressure Acoustics, Frequency Domain interface (🔊), where the Helmholtz equation is solved. Transient systems are modeled using the Pressure Acoustics, Transient interface (🔊), where the classical wave equation is solved. Nonlinear effects can be included here using the Nonlinear Acoustics (Westervelt) feature. The Boundary Mode Acoustics interface (🔊) is used to study propagating modes in waveguides and ducts (at a given frequency only a finite set of wave shapes can propagate over a long distance).

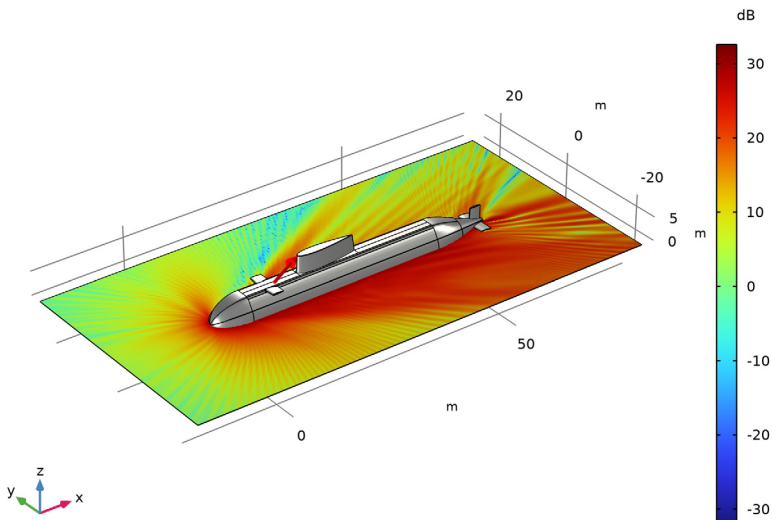





Figure 4: Scattered SPL odd a submarine hull modeled with the Asymptotic Scattering formulation.

To efficiently solve large radiation and scattering problems the Pressure Acoustics, Boundary Element interface (🔊) solves the Helmholtz equation using the

boundary element method (BEM). The interface is fully multiphysics enabled and couples seamlessly with the finite element based interfaces, both acoustic and structural. The Pressure Acoustics, Time Explicit () interface uses a time explicit method based on discontinuous Galerkin finite elements to efficiently solve large transient problems. This physics interface can also be solved on a GPU. It can also be coupled to the Elastic Waves, Time Explicit interface. Porous domains can be modeled in the time domain with this interface. Finally, two interfaces exist to model high-frequency acoustics: the Pressure Acoustics, Asymptotic Scattering interface () for scattering problems, and the Pressure Acoustics, Kirchhoff–Helmholtz interface () for radiation problems.

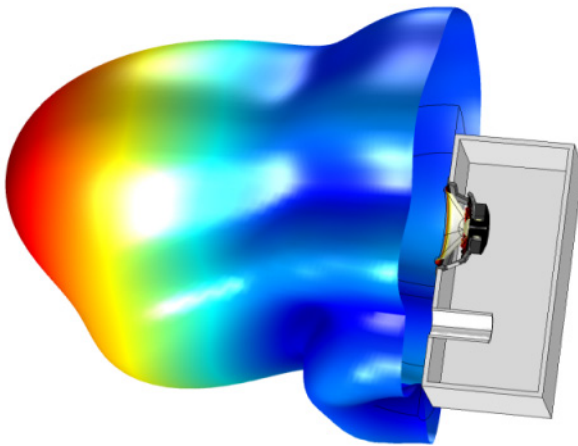



Figure 5: A 3D bubble plot of the loudspeaker radiation pattern at 3000 Hz. From the Vented Loudspeaker Enclosure model found in the application library. The model uses a hybrid FEM-BEM modeling setup.





A large variety of boundary conditions are available, including sound hard walls and conditions for applying sources. There are radiation, symmetry, periodic, and port conditions for modeling open boundaries. Impedance conditions include models for different parts of the human ear, human skin, simple RCL circuit models, and more. Frequency dependent impedance conditions in the time domain can be set up, using the built-in rational fitting approach. The physics interfaces also have several fluid models, which, in a homogenized way, mimic the behavior of sound propagation in more complex media. This includes the propagation in porous or fibrous materials (the Poroacoustics and Anisotropic Poroacoustics domain features), the propagation in narrow structures of constant cross section (the Narrow Region Acoustics domain feature), and fluid models for defining bulk absorption behavior. Monopole, dipole, and quadrupole point sources can also be applied. So-called perfectly matched layers (PMLs) are also

available to truncate an unbounded computational domain in both time and frequency domain. Finally, the exterior field calculation feature can be used to determine the pressure in any point outside the computational domain. Dedicated results and analysis capabilities exist for visualizing the radiation pattern of the exterior field (near and far-field) in polar, 2D, and 3D plots.

ELASTIC WAVES

The Elastic Waves branch () includes physics interfaces and multiphysics interfaces for modeling the propagation of linear elastic waves in solids, porous materials, and piezoelectric materials. If necessary, the interfaces are readily coupled to fluid domains using the built-in multiphysics couplings.



The physics interfaces under this branch are the:







- Solid Mechanics (Elastic Waves) (), for modeling elastic waves in solids. The Port boundary condition is specifically implemented to model and handle various propagating modes in elastic waveguide structures.
- Poroelastic Waves (), for precisely modeling the propagation of sound in a porous material (isotropic or anisotropic). It includes the two-way coupling between the deformation of the solid porous matrix and the pressure waves in the saturating fluid. The physics interface solves Biot's equations in the frequency domain (using a u-p formulation). It includes two formulations for the loss mechanisms: The Biot (viscous losses) for modeling rocks and soils and the Biot-Allard (or Biot-JCA, that includes thermal and viscous losses) for sound absorbing materials in air.
- Elastic Waves, Time Explicit (), for modeling the propagation of linear elastic waves in solids using the discontinuous Galerkin, time explicit formulation. The interface is suited for modeling large problems with a memory efficient method.
- Piezoelectric Waves, Time Explicit () multiphysics interface, for modeling linear elastic waves in piezoelectric materials using the discontinuous Galerkin, time explicit formulation. The interface is suited for modeling large problems with a memory efficient method.

ACOUSTIC-STRUCTURE INTERACTION

The Acoustic-Structure Interaction branch () has interfaces that apply to phenomena where the fluid pressure causes a load on the solid domain, and the structural acceleration affects the fluid domain across the fluid-solid boundary.

The physics interfaces under this branch are the:

- Acoustic-Solid Interaction, Frequency Domain () and Acoustic-Solid Interaction, Transient () multiphysics interfaces.

- Acoustic–Shell Interaction, Frequency Domain () and Acoustic–Shell Interaction, Transient () multiphysics interfaces.
- Acoustic–Piezoelectric Interaction, Frequency Domain () and Acoustic–Piezoelectric Interaction, Transient () multiphysics interfaces, which support solving and modeling the electric field in a piezoelectric material. The piezoelectric coupling can be in stress-charge or strain-charge form.
- Acoustic–Solid–Poroelastic Waves Interaction () and Acoustic–Poroelastic Waves Interaction () multiphysics interfaces.
- Acoustic–Solid Interaction, Time Explicit () multiphysics interface.
- The multiphysics interfaces consist of two or more single physics interfaces, for example, Pressure Acoustics, Frequency Domain and Solid Mechanics together with a multiphysics coupling, here the Acoustic–Structure Boundary coupling. Many more couplings are supported, for example, coupling Pressure Acoustics to Membrane or Multibody Dynamics interfaces.

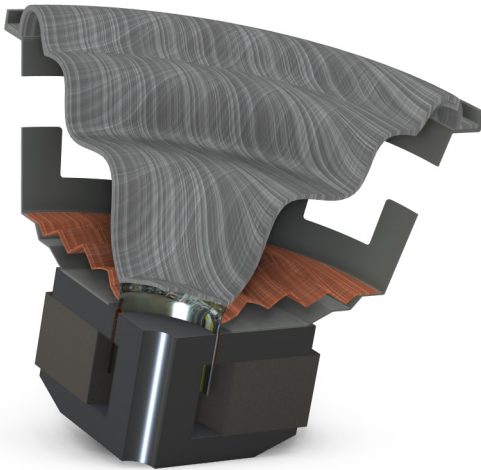













Figure 6: Loudspeaker driver simulations in 3D including all multiphysics effects.

AEROACOUSTICS

Detailed convected acoustics (flow borne noise/sound) that simulates the one-way interaction of a background fluid flow with an acoustic field is modeled using the physics interfaces found under the Aeroacoustics branch (). The coupling between the fluid mechanics and the acoustics is based on solving the set of linearized governing equations using stabilized finite elements methods. In this way, you solve for the acoustic variations of the acoustic variables on top of a

stationary background mean flow. Different physics interfaces exist that solve the governing equations under various physical approximations.

- The Linearized Navier–Stokes, Frequency Domain () and Linearized Navier–Stokes, Transient () interfaces are used for aeroacoustic simulations that can be described by the linearized Navier–Stokes equations solving for the acoustic variations in pressure, velocity, and temperature. The Linearized Navier–Stokes, Boundary Mode interface () is used to compute and identify propagating and nonpropagating modes in waveguides and ducts in the presence of a background flow.
- The Linearized Euler, Frequency Domain interface () and the Linearized Euler, Transient interface () solve the Linearized Euler equations. They are used to compute the acoustic variations in density, velocity, and pressure in the presence of a stationary background mean-flow that is well approximated by an ideal gas flow. The Linearized Euler, Boundary Mode interface () is used to compute and identify propagating and nonpropagating modes in waveguides and ducts in the presence of a background flow.
- The Linearized Potential Flow, Frequency Domain () and the Linearized Potential Flow, Transient () interfaces model the interaction of a stationary background potential flow with an acoustic field. These physics interfaces are only suited for cases where the flow is inviscid and, being irrotational, has no vorticity. The background flow is typically solved for using the Compressible Potential Flow interface (). The Linearized Potential Flow, Boundary Mode interface () is used to study boundary mode acoustic problems, identifying propagating and nonpropagating modes, in a background flow field. It is typically used to define sources at the inlet of ducts using the port boundary condition.
- The Imported Fluid Flow () interface is used to map imported fluid flow data, in the CGNS format, onto an acoustics mesh. The interface also integrates with the necessary multiphysics couplings.

THERMOVISCOUS ACOUSTICS

The physics interfaces under the Thermoviscous Acoustics branch () are used to accurately model acoustics in geometries with small dimensions. Near walls viscous and thermal boundary layers (penetration depths) exist. Here, viscous losses due to shear and thermal conduction become important because of large gradients. For this reason, it is necessary to include thermal conduction effects and viscous losses explicitly in the governing equations. Thermoviscous acoustics is, for example, used when modeling the response of small transducers like microphones and receivers. Other applications include analyzing feedback in hearing aids and in mobile devices, or studying the damped vibrations of MEMS

structures. In this case, a coupling exists to the Thermoelasticity interface for detailed damping assessment. In the time domain, nonlinear effects can be modeled using the Nonlinear Thermoviscous Acoustics Contributions feature. Because a detailed description is needed to model thermoviscous acoustics, the physics interface simultaneously solves for the acoustic pressure p , the particle velocity vector \mathbf{u} , and the acoustic temperature variation T .

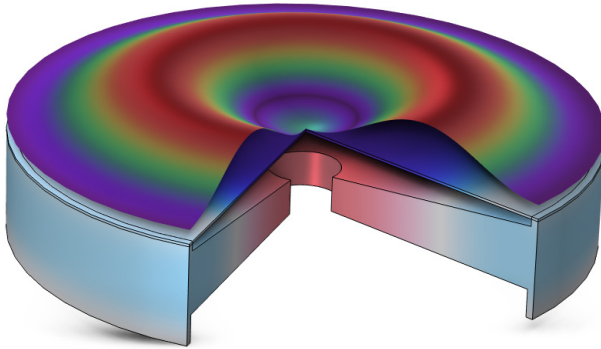











Figure 7: Deformation of the diaphragm (or membrane) and internal pressure distribution at 125 kHz in the Axisymmetric Condenser Microphone model found in the application library.



In the Thermoviscous Acoustics, Frequency Domain interface (), the governing equations are implemented in the time-harmonic formulation and solved in the frequency domain. The interface is given in the scattered field formulation. Both mechanical and thermal boundary conditions exist. The interface exists in a time domain formulation, the Thermoviscous Acoustics, Transient interface (). The Thermoviscous Acoustics, Boundary Mode interface () is used to compute and identify propagating and nonpropagating modes in waveguides and ducts. The interface performs a boundary mode analysis on a boundary, inlet, or cross section of a waveguide or duct of small dimensions. The Thermoviscous, SLNS Approximation interface () uses a fast approximative formulation of the equations that is valid in most cases. Several multiphysics interfaces involving thermoviscous acoustics also exist:

- Acoustic–Thermoviscous Acoustic Interaction, Frequency Domain multiphysics interface () that includes Pressure Acoustics, Frequency Domain and the Acoustics–Thermoviscous Acoustics Boundary coupling feature. Coupling the thermoviscous acoustics domain to a pressure acoustics domain is also straightforward, with the predefined multiphysics condition.

- A Thermoviscous Acoustic–Solid Interaction, Frequency Domain multiphysics interface () is available to solve coupled vibroacoustic problems. This can, for example, be used to model small electroacoustic transducers or damping in MEMS devices. It includes Solid Mechanics and the predefined multiphysics coupling to Thermoviscous Acoustics.
- The Thermoviscous Acoustic–Shell Interaction, Frequency Domain multiphysics interface () is used for modeling the interactions between shells and acoustics in small dimensions. This can, for example, be used to analyze the damped vibrations of shells in hearing aids and prevent feedback problems.
- The Thermoviscous Acoustic–Thermoelasticity Interaction, Frequency Domain () and the Thermoviscous Acoustic–Thermoelasticity Interaction, Transient () interfaces are specialized multiphysics interfaces for modeling the coupled effects of viscous, structural, and thermal damping in a vibroacoustic setup.

ULTRASOUND

Two dedicated interfaces exist under the Ultrasound branch ().

- The Convected Wave Equation, Time Explicit () interface which is used to solve large transient linear acoustic problems containing many wavelengths in a stationary background flow. In general, the interface is suited for modeling the propagation of acoustic signals over large distances relative to the wavelength, for example, linear ultrasound problems. Application areas include ultrasound flowmeters and other ultrasound sensors where time of flight is an important parameter.
- The Nonlinear Pressure Acoustics, Time Explicit () interface is used to model the propagation of high amplitude nonlinear acoustic waves. Special functionality exists to capture shocks. Application areas include biomedical applications, for instance, ultrasonic imaging and high-intensity focused ultrasound (HIFU). The applications are not restricted to ultrasound.

Both interfaces include absorbing layers that are used to set up effective nonreflecting-like boundary conditions. Both interfaces also couple to Elastic Waves, Time Explicit using built-in multiphysics couplings. The interfaces are based on the discontinuous Galerkin method and use a time explicit solver. The method is very memory lean.

GEOMETRICAL ACOUSTICS



Two physics interfaces exist under the Geometrical Acoustics branch: the Acoustic Diffusion Equation interface and the Ray Acoustics interface. Both are used to

model acoustics in the high frequency limit where the wavelength is significantly smaller than the characteristic geometrical features.



The Ray Acoustics physics interface is used to compute the trajectories, phase, and intensity of acoustic rays. The interface can be used to model room acoustic problems like concert halls, lecture halls, or car cabins, and many outdoor and underwater environments. The interface has a dedicated receiver dataset that is used to create an impulse response plot. Objective room acoustic metrics like clarity, definition, and reverberation time can be analyzed.

The Acoustic Diffusion Equation interface solves a diffusion equation for the acoustic energy density distribution for modeling indoor room acoustics in buildings and concert halls. It is also known as energy finite elements.

PIPE ACOUSTICS







The Pipe Acoustics, Transient () and the Pipe Acoustics, Frequency Domain () interfaces are used to model the propagation of sound waves in 1D flexible pipe systems. The equations are formulated in a general way to include the effects of the pipe wall compliance and allow the possibility of a stationary background flow. The pipe interfaces can be coupled to pressure acoustics domains using the built-in Acoustic–Pipe Acoustics Connection multiphysics coupling.









ACOUSTIC STREAMING













Two multiphysics interfaces exist under the Acoustic Streaming () branch. Both interfaces feature dedicated domain and boundary multiphysics couplings to model acoustic streaming phenomena, that is, the generation of flow by an acoustic field. The Acoustic Streaming from Pressure Acoustics () couples Pressure Acoustics, Frequency Domain to Laminar Flow using an effective theory. The Acoustic Streaming from Thermoviscous Acoustics () couples Thermoviscous Acoustics, Frequency Domain to Laminar Flow including full resolution of the acoustic boundary layers.











Physics Interface Guide by Space Dimension and Study Type















The table below lists the physics interfaces available specifically with this module in addition to those in the COMSOL Multiphysics basic license.







PHYSICS INTERFACE	ICON	TAG	SPACE DIMENSION	AVAILABLE STUDY TYPE
))) Acoustics				
))) Pressure Acoustics				
Pressure Acoustics, Frequency Domain ¹		acpr	all dimensions	eigenfrequency; frequency domain; frequency domain, modal; adaptive frequency sweep; mode analysis (2D and 1D axisymmetric models only); boundary mode analysis (3D and 2D axisymmetric models only)
Pressure Acoustics, Transient		actd	all dimensions	eigenfrequency; frequency domain; frequency domain, modal; time dependent; time dependent, modal; mode analysis (2D and 1D axisymmetric models only)
Pressure Acoustics, Boundary Mode		acbm	3D, 2D axisymmetric	mode analysis
Pressure Acoustics, Boundary Elements		pabe	3D, 2D	frequency domain
Pressure Acoustics, Time Explicit		pate	3D, 2D, 2D axisymmetric	time dependent
Pressure Acoustics, Asymptotic Scattering		paas	3D	frequency domain
Pressure Acoustics, Kirchhoff–Helmholtz		pakh	3D	frequency domain







PHYSICS INTERFACE	ICON	TAG	SPACE DIMENSION	AVAILABLE STUDY TYPE
 Elastic Waves				
Solid Mechanics (Elastic Waves) ¹		solid	3D, 2D, 2D axisymmetric	stationary; eigenfrequency; eigenfrequency, prestressed; mode analysis; time dependent; time dependent, modal; time dependent, modal reduced-order model; frequency domain; frequency domain, modal; frequency domain, prestressed; frequency domain, prestressed, modal; frequency domain, modal reduced-order model; frequency domain, AWE reduced-order model; modal reduced-order model
Poroelastic Waves		pelw	3D, 2D, 2D axisymmetric	eigenfrequency; frequency domain; frequency domain, modal
Elastic Waves, Time Explicit		elte	3D, 2D, 2D axisymmetric	time dependent
Piezoelectric Waves, Time Explicit		—	3D, 2D, 2D axisymmetric	time dependent
 Acoustic-Structure Interaction				
Acoustic-Solid Interaction, Frequency Domain ³		—	3D, 2D, 2D axisymmetric	eigenfrequency; frequency domain; frequency domain, modal
Acoustic-Solid Interaction, Transient ³		—	3D, 2D, 2D axisymmetric	eigenfrequency; frequency domain; frequency domain, modal; time dependent; time dependent, modal
Acoustic-Shell Interaction, Frequency Domain ^{2,3}		—	3D, 2D axisymmetric	eigenfrequency; frequency domain; frequency domain, modal



PHYSICS INTERFACE	ICON	TAG	SPACE DIMENSION	AVAILABLE STUDY TYPE
Acoustic–Shell Interaction, Transient ^{2, 3}		—	3D, 2D axisymmetric	eigenfrequency; frequency domain; frequency domain, modal; time dependent; time dependent, modal
Acoustic–Piezoelectric Interaction, Frequency Domain ³		—	3D, 2D, 2D axisymmetric	eigenfrequency; frequency domain; frequency domain, modal
Acoustic–Piezoelectric Interaction, Transient ³		—	3D, 2D, 2D axisymmetric	eigenfrequency; frequency domain; frequency domain, modal; time dependent; time dependent, modal
Acoustic–Solid–Poroelastic Waves Interaction ³		—	3D, 2D, 2D axisymmetric	eigenfrequency; frequency domain; frequency domain, modal
Acoustic–Poroelastic Waves Interaction ³		—	3D, 2D, 2D axisymmetric	eigenfrequency; frequency domain; frequency domain, modal
Acoustic–Solid Interaction, Time Explicit		—	3D, 2D	time domain
 Aeroacoustics				
Linearized Euler, Frequency Domain		lef	3D, 2D, 2D axisymmetric, 1D	frequency domain; eigenfrequency
Linearized Euler, Transient		let	3D, 2D, 2D axisymmetric, 1D	time dependent
Linearized Euler, Boundary Mode		lebm	3D, 2D axisymmetric	mode analysis
Linearized Potential Flow, Frequency Domain		ae	all dimensions	frequency domain; mode analysis (2D and 1D axisymmetric models only)
Linearized Potential Flow, Transient		aetd	all dimensions	frequency domain; time dependent; mode analysis (2D and 1D axisymmetric models only)

PHYSICS INTERFACE	ICON	TAG	SPACE DIMENSION	AVAILABLE STUDY TYPE
Linearized Potential Flow, Boundary Mode		aebm	3D, 2D axisymmetric	mode analysis
Compressible Potential Flow		cpf	all dimensions	stationary; time dependent
Linearized Navier–Stokes, Frequency Domain		lnsf	3D, 2D, 2D axisymmetric, 1D	frequency domain; eigenfrequency
Linearized Navier–Stokes, Transient		lnst	3D, 2D, 2D axisymmetric, and 1D	time dependent
Linearized Navier–Stokes, Boundary Mode		lnsbm	3D, 2D axisymmetric	mode analysis
))) Thermoviscous Acoustics				
Thermoviscous Acoustics, Frequency Domain		ta	all dimensions	eigenfrequency; frequency domain; frequency domain, modal; mode analysis (2D and 1D axisymmetric models only)
Thermoviscous Acoustics, Transient		tatd	all dimensions	time dependent
Thermoviscous Acoustics, Boundary Mode		tabm	3D, 2D axisymmetric	mode analysis
Thermoviscous Acoustics, SLNS Approximation		slns	3D, 2D, 2D axisymmetric	frequency domain
Acoustic–Thermoviscous Acoustic Interaction, Frequency Domain ³		—	3D, 2D, 2D axisymmetric	eigenfrequency; frequency domain; frequency domain, modal; boundary mode analysis (3D and 2D axisymmetric only); mode analysis (2D only)
Thermoviscous Acoustic–Solid Interaction, Frequency Domain ³		—	3D, 2D, 2D axisymmetric	eigenfrequency; frequency domain; frequency domain, modal; mode analysis (2D only)

PHYSICS INTERFACE	ICON	TAG	SPACE DIMENSION	AVAILABLE STUDY TYPE
Thermoviscous Acoustic–Shell Interaction, Frequency Domain ^{2,3}		—	3D, 2D axisymmetric	eigenfrequency; frequency domain; frequency domain, modal
Thermoviscous Acoustic–Thermoelasticity Interaction, Frequency Domain ⁵		—	3D, 2D, 2D axisymmetric	frequency domain perturbation
Thermoviscous Acoustic–Thermoelasticity Interaction, Transient ⁵		—	3D, 2D, 2D axisymmetric	time dependent
 Ultrasound				
Convected Wave Equation, Time Explicit		cwe	3D, 2D, 2D axisymmetric	time dependent
Nonlinear Pressure Acoustics, Time Explicit		nate	3D, 2D, 2D axisymmetric	time dependent
 Geometrical Acoustics				
Ray Acoustics		rac	3D, 2D, 2D axisymmetric	ray tracing; time dependent
Acoustic Diffusion Equation		ade	3D	eigenvalue; stationary; time dependent
 Pipe Acoustics				
Pipe Acoustics, Frequency Domain		pafd	3D, 2D	eigenfrequency; frequency domain
Pipe Acoustics, Transient		patd	3D, 2D	time dependent
 Acoustic Streaming				
Acoustic Streaming from Pressure Acoustics		—	3D, 2D, 2D axisymmetric	frequency–stationary, frequency–transient

PHYSICS INTERFACE	ICON	TAG	SPACE DIMENSION	AVAILABLE STUDY TYPE
Acoustic Streaming from Thermoviscous Acoustics		—	3D, 2D, 2D axisymmetric	frequency–stationary, frequency–transient
 Structural Mechanics				
Solid Mechanics ¹		solid	3D, 2D, 2D axisymmetric, 1D, 1D axisymmetric	stationary; eigenfrequency; eigenfrequency, prestressed; mode analysis; time dependent; time dependent, modal; time dependent, modal reduced-order model; frequency domain, modal; frequency domain, prestressed; frequency domain, prestressed, modal; frequency domain, modal reduced-order model; frequency domain, AWE reduced-order model
 Piezoelectricity				
Piezoelectricity, Solid		—	3D, 2D, 2D axisymmetric	stationary; eigenfrequency; eigenfrequency, prestressed; time dependent; time dependent, modal; frequency domain; frequency domain, modal; frequency domain, prestressed; frequency domain, prestressed, modal; small-signal analysis, frequency domain
 Magnetomechanics				

PHYSICS INTERFACE	ICON	TAG	SPACE DIMENSION	AVAILABLE STUDY TYPE
Piezomagnetism ^{3,4}		—	3D, 2D, 2D axisymmetric	stationary; eigenfrequency; time dependent; frequency domain; small-signal analysis, frequency domain; eigenfrequency, prestressed; frequency domain, prestressed
Nonlinear Magnetostriction ^{3,4}		—	3D, 2D, 2D axisymmetric	stationary; eigenfrequency; time dependent; frequency domain; small-signal analysis, frequency domain; eigenfrequency, prestressed; frequency domain, prestressed
Magnetomechanics, Solids ^{3,4}		—	3D, 2D, 2D axisymmetric	stationary; eigenfrequency; time dependent; frequency domain; small-signal analysis, frequency domain; eigenfrequency, prestressed; frequency domain, prestressed
Magnetomechanics, No Currents, Solids ^{3,4}		—	3D, 2D, 2D axisymmetric	stationary; eigenfrequency; time dependent; frequency domain; small-signal analysis, frequency domain; eigenfrequency, prestressed; frequency domain, prestressed
Magnetomechanics, Shell ^{3,4}		—	3D, 2D axisymmetric	stationary; eigenfrequency; time dependent; frequency domain; small-signal analysis, frequency domain; eigenfrequency, prestressed; frequency domain, prestressed
Magnetomechanics, No Currents, Shell ^{3,4}		—	3D, 2D axisymmetric	stationary; eigenfrequency; time dependent; frequency domain; small-signal analysis, frequency domain; eigenfrequency, prestressed; frequency domain, prestressed

PHYSICS INTERFACE		ICON	TAG	SPACE DIMENSION	AVAILABLE STUDY TYPE
	Magnetomechanics, Membrane ^{3,4}		—	3D, 2D axisymmetric	stationary; eigenfrequency; time dependent; frequency domain; small-signal analysis, frequency domain; eigenfrequency, prestressed; frequency domain, prestressed
	Magnetomechanics, No Currents, Membrane ^{3,4}		—	3D, 2D axisymmetric	stationary; eigenfrequency; time dependent; frequency domain; small-signal analysis, frequency domain; eigenfrequency, prestressed; frequency domain, prestressed

¹ This physics interface is included with the core COMSOL package but has added functionality for this module.



² Requires both the Structural Mechanics Module and the Acoustics Module.







³ This physics interface is a predefined multiphysics coupling that automatically adds all the physics interfaces and coupling features required.

⁴ Requires the addition of the AC/DC Module.

⁵ Requires both the MEMS Module and the Acoustics Module.

The Application Libraries Window

To open an Acoustics Module application library model or tutorial, in the File menu click Application Libraries . In the Application Libraries window that opens, expand the Acoustics Module folder and browse or search the contents. Click Open Application  to open it in COMSOL Multiphysics or click Open PDF Document  to read background information including the step-by-step instructions to build it. The MPH files in the COMSOL application library can have three formats — solved, compact, or preview MPH files.

- Solved MPH files, including all meshes and solutions. In the Application Libraries window these appear with the  icon. If the MPH file's size exceeds 25MB, a tip with the text “Large file” and the file size appears when you position the cursor at the model's node in the Application Libraries tree.
- Compact MPH files with all settings for the model but without built meshes and solution data to save space (a few MPH files have no solutions for other reasons). You can open these to study the settings and to mesh and re-solve the applications. It is also possible to download the full versions — with meshes and solutions — of most of these when you update your application library. These appear in the Application Libraries window with the  icon and for runnable applications, this icon (). If you position the cursor at a compact file in the Application Libraries window, a No solutions stored message appears. If a full MPH file is available for download, the corresponding node's context menu includes a Download File with Solutions () option.
- Preview MPH files () are not actual model MPH files. They just contain the information needed to present a model in the Application Libraries window. To get the actual model, choose Download File with Solutions () or Download File Without Solutions () from the node's context menu.

To check all available Application Libraries updates, select Update COMSOL Application Library () either from the top of the Application Libraries window, from the File > Help menu (Windows users), or from the Help menu (Mac and Linux users).

To find further examples, available on the COMSOL homepage, click the Application Galley () button. The gallery contains all the library models and many more. It is a great location for finding resources on various acoustic topics.

Get started with the [Example: Absorptive Muffler](#). The last section, [Additional Examples from the Application Libraries](#), provides a brief overview of some of the other models also available in the Acoustics Module Application Library.

Basics of Acoustics

Acoustics is the physics of sound. Sound is the sensation, as detected by the ear, of very small rapid changes in the acoustic pressure p above and below a static value p_0 . This static value is the atmospheric pressure (about 100,000 pascals).

The amplitude of the small pressure variations that can be detected by the human ear vary from roughly $2 \cdot 10^{-5}$ Pa at the hearing threshold to 20 Pa for jet engine noise. The amplitude at normal speech levels is about 0.02 Pa. The amplitudes described here are often given on the logarithmic decibel scale, relative to the hearing threshold value of $2 \cdot 10^{-5}$ Pa, in units of dB SPL.

The acoustic pressure variations are typically described as pressure waves propagating in space and time. The wave crests are the pressure maxima while the troughs represent the pressure minima.

In more general terms, sound is created when the fluid is disturbed by a source. An example is a vibrating object, such as a speaker cone in a sound system. It is possible to see the movement of a bass speaker cone when it generates sound at a very low frequency. As the cone moves forward it compresses the air in front of it, causing an increase in air pressure. Then it moves back past its resting position and causes a reduction in air pressure. This process continues, radiating a wave of alternating high and low pressure at the speed of sound.

The frequency f (SI unit: Hz = 1/s) is the number of vibrations (pressure peaks) perceived per second and the wavelength λ (SI unit: m) is the distance between two such peaks. The speed of sound c (SI unit: m/s) is given as the product of the frequency and the wavelength, $c = \lambda f$. It is often convenient to define the angular frequency ω (SI unit: rad/s) of the wave, which is $\omega = 2\pi f$, and relates the frequency to a full 360° phase shift. The wave number k (SI unit: rad/m) is defined as $k = 2\pi/\lambda$. The wave number, which is the number of waves over a specific distance, is also usually defined as a vector \mathbf{k} , such that it also contains information about the direction of propagation of the wave, with $|\mathbf{k}| = k$. In general, the relation between the angular frequency ω and the wave number k is called the dispersion relation; for simple fluids it is $\omega/k = c$.

Governing Equations

The equations that describe the propagation of sound in fluids are derived from the governing equations of fluid flow. That is, conservation of mass, which is described by the continuity equation; the conservation of momentum, which is often referred to as the Navier–Stokes equations; an energy conservation equation; the constitutive equations of the model; and an equation of state to describe the relation between thermodynamic variables. In the classical case of pressure acoustics, which describes most acoustic phenomena accurately, the flow is

assumed lossless and adiabatic, viscous effects are neglected, and a linearized isentropic equation of state is used.

Under these assumptions, the acoustic field is described by one variable, the pressure p (SI unit: Pa), and is governed by the wave equation

$$\frac{1}{\rho_0 c^2} \frac{\partial^2 p}{\partial t^2} + \nabla \cdot \left(-\frac{1}{\rho_0} \nabla p \right) = 0$$

where t is time (SI unit: s), ρ_0 is the density of the fluid (SI unit: kg/m³), and c is the (adiabatic) speed of sound (SI unit: m/s).

Acoustic problems often involve simple harmonic waves such as sinusoidal waves. More generally, any signal may be expanded into harmonic components via its Fourier series. The wave equation can then be solved in the frequency domain for one frequency at a time. A harmonic solution has the form

$$p(\mathbf{x}, t) = p(\mathbf{x}) \sin(\omega t)$$

where the spatial $p(\mathbf{x})$ and temporal $\sin(\omega t)$ components are split. The pressure may be written in a more general way using complex variables

$$p(\mathbf{x}, t) = p(\mathbf{x}) e^{i\omega t} \tag{1}$$

where the actual (instantaneous) physical value of the pressure is the real part of [Equation 1](#). Using this assumption for the pressure field, the time-dependent wave equation reduces to the well-known Helmholtz equation

$$\nabla \cdot \left(-\frac{1}{\rho_0} \nabla p \right) - \frac{\omega^2}{\rho_0 c^2} p = 0 \tag{2}$$

In the homogeneous case, one simple solution to the Helmholtz equation ([Equation 2](#)) is the plane wave

$$p = P_0 e^{i(\omega t - \mathbf{k} \cdot \mathbf{x})} \tag{3}$$

where P_0 is the wave amplitude, and it is moving in the \mathbf{k} direction with angular frequency ω and wave number $k = |\mathbf{k}|$.

In most practical situations, an exact analytical solution to [Equation 2](#) does not exist. Solving the equation requires a numerical approach using simulations.

Numerical Methods

As mentioned, solving the governing equations for the acoustic problems analytically — like, for example, the Helmholtz equation ([Equation 2](#)) — is only possible in a few simple situations. In order to solve real-life industrial problems,

which can very well be multiphysics problems involving several coupled physics, numerical methods are necessary. This is the job of COMSOL Multiphysics. In the Acoustics Module, most of the physics interfaces are based on the finite element method (FEM). In order to extend the range of models that can be solved, the Acoustics Module also includes the Pressure Acoustics, Boundary Elements interface based on BEM, two interfaces based on the discontinuous Galerkin (dG-FEM) method, and Ray Acoustics that uses a ray tracing method.

Solving a model using FEM requires a computational mesh. The solution is approximated on each mesh element (the finite elements) by a shape function (a local basis or interpolation function). Setting up this system of mesh elements and local shape functions leads to a discrete vector-matrix problem that needs to be solved. After solving the matrix problem with an adequate method, the solution to the original problem can be reconstructed. When solving wave problems numerically, one should be aware of the time and length scales involved in the problem, as will be discussed below.

Length and Time Scales

When solving acoustic problems, it is important to think about the different basic length and time scales involved in the system. Some of the scales are set by the physics of the problem, while others are set by the numerical solution method. The relative size of these scales may influence the accuracy of the solution but also the selection of the physics interface used to model the problem.

When working with acoustics in the frequency domain, that is, solving the Helmholtz equation, only one time scale T exists (the period) and it is set by the frequency, $T = 1/f$. Several length scales exist: the wavelength $\lambda = c/f$, the smallest geometric dimension L_{\min} , the mesh size h , and the thickness of the acoustic boundary layer δ (the latter is discussed in [Models with Losses](#)). In order to get an accurate solution, the mesh should be fine enough to both resolve the geometric features and the wavelength. As a rule of thumb, the maximal mesh size should be less than or equal to λ/N , where N is a number between 5 and 10, and depends on the spatial discretization.

Note that when the wavelength becomes smaller than the characteristic length scale in the model, the two interfaces in Geometrical Acoustics can be used. The equations solved here do not require the same mesh constraints and can be used to model much larger systems (measured in wavelengths) compared to solving, for example, the Helmholtz equation.

For transient acoustic problems the same considerations apply. However, several new time scales are also introduced. One is given by the frequency contents of the signal and by the desired maximal frequency resolution: $T = 1/f_{\max}$. The other is given by the size of the time step Δt used by the numerical solver. A condition on

the so-called CFL condition dictates the relation between the time step size and the minimal mesh size h_{\min} , the Courant number is defined as

$$C_{\text{CLF}} = \frac{c \Delta t}{h_{\min}} \quad (4)$$

where c is the speed of sound in the system. For all the transient interfaces available with the Acoustics Module the solver is automatically set up to fulfill this criterion. For the interfaces based on FEM the condition is interpreted to achieve an adequate balance between resolution in time and space. The user is only required to enter the maximal frequency f_{\max} to be resolved by the model. For the dG-FEM based interfaces the condition is used explicitly to achieve both accuracy and stability.

In order to run accurate acoustic simulations, it is important to think about these physical and numerical scales and about their influence on the convergence and correctness of the numerical solution. A good practical approach is to test the robustness of a solution compared to changes in the mesh in all cases and the numerical time stepping in the transient problems. If some measure of the solution, within a given accuracy range, changes when the mesh is refined then the mesh was probably not good enough.

Boundary Conditions

Boundary conditions define the nature of the boundaries of the computational domain. Some define real physical obstacles, like a sound hard wall or a moving interface. Others, called artificial boundary conditions, are used to truncate the domain. The artificial boundary conditions are, for example, used to simulate an open boundary where no sound is reflected. It may also mimic a reacting boundary such as a perforated plate.

Elastic Waves

The propagation of sound in solids happens through small-amplitude elastic oscillations of the solids shape and structure. These elastic waves are transmitted to surrounding fluids as ordinary sound waves. Through acoustic–structure interaction, the fluid pressure causes a fluid load on the solid domain, and the structural acceleration affects the fluid domain as a normal acceleration across the fluid-solid boundary. This is also known as vibroacoustics.

The Acoustics Module has the Poroelastic Waves interface available to model poroelastic waves that propagate in porous materials. These waves result from the complex interaction between acoustic pressure variations in the saturating fluid and the elastic deformation of the solid porous matrix.

Models with Losses

In order to accurately model acoustics in geometries with small dimensions, it is necessary to include thermal conduction effects and viscous losses explicitly in the governing equations. Near walls, viscosity and thermal conduction become important because the acoustic field creates viscous and thermal boundary layers where losses are significant. A detailed description is needed to model these phenomena; the dedicated Thermoviscous Acoustics, Frequency Domain interface solves the full linearized Navier–Stokes, continuity, and energy equations simultaneously. The physics interface solves for the acoustic pressure p , the particle velocity vector \mathbf{u} , and the acoustic temperature variation T . These are the acoustic variations on top of the mean background values.

The length scale at which the thermoviscous acoustic description is necessary is given by the thickness of the viscous (v) and thermal (th) boundary layers

$$\delta_v = \sqrt{\frac{\mu}{\pi f \rho}} \quad \delta_{th} = \sqrt{\frac{k}{\pi f \rho C_p}}$$

where μ is the dynamic viscosity, k is the coefficient of thermal conduction, and C_p is the specific heat capacity at constant pressure. These two length scales define an acoustic boundary layer that needs to be resolved by the computational mesh.

Another way to introduce losses in the governing equations is to use the equivalent fluid models available in the pressure acoustics interfaces. In a homogenized way, this introduces attenuation properties to the bulk fluid that mimic different loss mechanisms. This is in contrast to the thermoviscous acoustics interfaces that model losses explicitly where they happen, that is, in the acoustic boundary layer near walls. The fluid models include losses due to bulk thermal conduction and viscosity (in the main Pressure Acoustics domain feature), models for simulating the damping in certain porous materials (in the Poroacoustics domain feature), and models to mimic the boundary absorption losses in long narrow ducts (the Narrow Region Acoustics domain feature). When applicable, the equivalent fluid models are computationally much less heavy than, for example, solving a corresponding full poroelastic model.

Geometrical Acoustics

At high frequencies when the wavelength is much smaller than the characteristic geometric features, it is impractical to solve acoustic problems using pressure acoustics. Here, other methods are used like, for example, ray methods or energy diffusion analogies. These are known as geometrical acoustics methods and are used for modeling room acoustics, concert hall acoustics, and outdoor propagation over large distances. The Geometrical Acoustics branch includes the Ray Acoustics and the Acoustic Diffusion Equation interfaces.

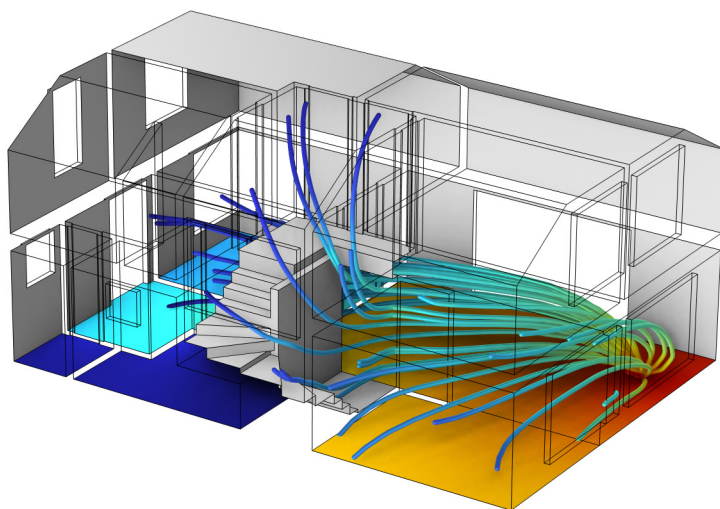

Figure 8: Sound pressure level and energy flux inside a two story house modeled using the Acoustic Diffusion Equation physics interface. Figure taken from the One-Family House Acoustics model found in the Application Library.

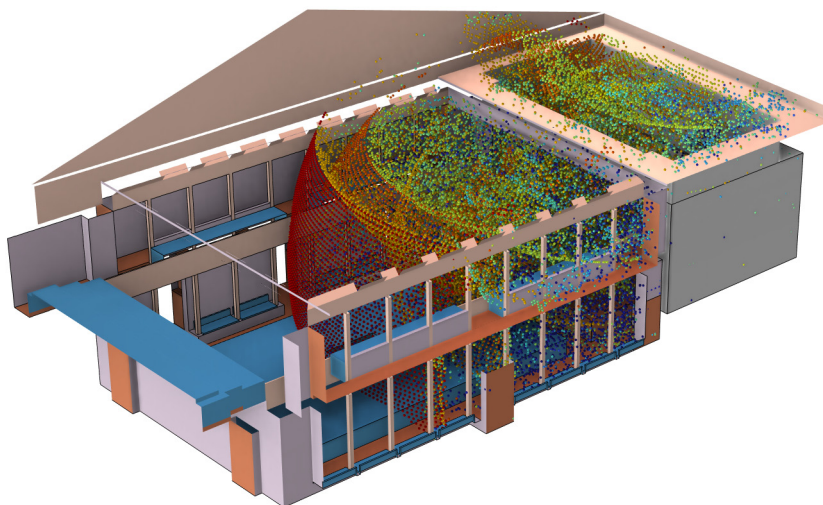

Figure 9: Ray tracing model of a chamber music hall including the ray location at 35 ms. Figure taken from the Chamber Music Hall model found in the Application Library.

Example: Absorptive Muffler

This example describes the pressure-wave propagation in a muffler for an internal combustion engine. The approach used here is generally applicable to analyzing the damping of propagating pressure waves as well as determining the transmission properties of a given system. The model uses the port boundary conditions to model the inlet and outlet of the muffler. The model shows how to analyze both inductive and resistive damping in pressure acoustics. The main output is the transmission loss for the frequency range 50 Hz–2800 Hz. It is represented both as a continuous curve and given in 1/3 octave bands.

Model Definition

The muffler, schematically shown in the figure below, consists of a 24-liter resonator chamber with a section of the centered exhaust pipe included at each end. The model is first set up assuming that the chamber is empty. Secondly, it is lined with 15 mm of absorbing glass wool.

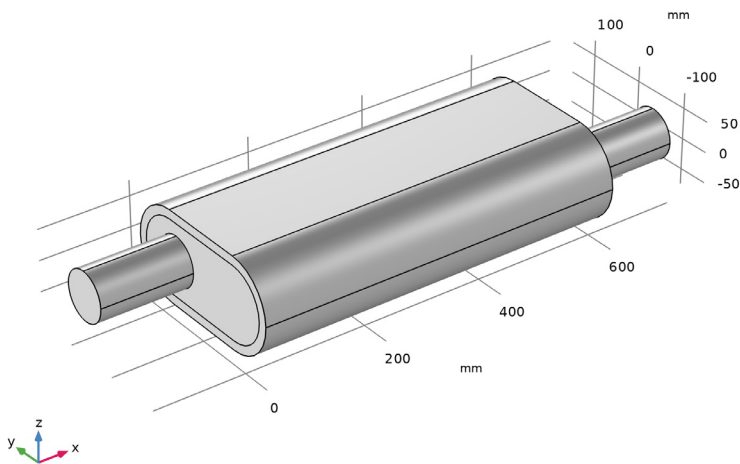

Figure 10: Geometry of the lined muffler; the liner is the outer layer in the main muffler volume. The exhaust fumes enter through the left pipe and exit through the right pipe.

Domain Equations

This model solves the problem in the frequency domain using the Pressure Acoustics, Frequency Domain interface. The model equation is a slightly modified version of the Helmholtz equation for the acoustic pressure p :

$$\nabla \cdot \left(-\frac{\nabla p}{\rho_c} \right) - \frac{\omega^2 p}{c_c^2 \rho_c} = 0$$

where ρ is the density, c is the speed of sound, and ω gives the angular frequency. The subscript c refers to that these material properties can be complex valued.

In the absorbing glass wool, modeled as a Poroacoustics domain, the damping enters the equation as a complex speed of sound, $c_c = \omega/k_c$, and a complex density, $\rho_c = k_c Z_c/\omega$, where k_c is the complex wave number and Z_c equals the complex impedance. This is a so-called equivalent fluid model for the porous domain where the losses are modeled in a homogenized way.

For a highly porous material with a rigid skeleton, the well-known model of Delany and Bazley estimates these parameters as functions of frequency and flow resistivity. This class of poroacoustic models is named Delany–Bazley–Miki in the user interface. Using the original coefficients/constants of Delany and Bazley (Ref. 1), the expressions are

$$k_c = k_0 \cdot \left(1 + 0.098 \cdot \left(\frac{\rho_f f}{R_f} \right)^{-0.7} - i \cdot 0.189 \cdot \left(\frac{\rho_f f}{R_f} \right)^{-0.595} \right)$$

$$Z_c = Z_0 \cdot \left(1 + 0.057 \cdot \left(\frac{\rho_f f}{R_f} \right)^{-0.734} - i \cdot 0.087 \cdot \left(\frac{\rho_f f}{R_f} \right)^{-0.732} \right)$$

where R_f is the flow resistivity, and where $k_0 = \omega/c$ and $Z_0 = \rho_f c_a$ are the free-space wave number and impedance of air, respectively. Several different coefficients/constants for the empirical fitting model can be selected in the Poroacoustics feature, each representing different porous or fibrous materials. The Delany–Bazley–Miki model is the default selected in the Poroacoustics domain feature. Several porous models can be selected here depending on the situation at hand. You can find flow resistivities in tables, see for example Ref. 3 or by measuring it. For glass-wool-like materials, Bies and Hansen (Ref. 2) give an empirical correlation

$$R_f = \frac{3.18 \cdot 10^{-9} \cdot \rho_{ap}^{1.53}}{d_{av}^2}$$

where ρ_{ap} is the material's apparent density and d_{av} is the mean fiber diameter. This model uses a lightweight glass wool with $\rho_{ap} = 12 \text{ kg/m}^3$ and $d_{av} = 10 \text{ }\mu\text{m}$.

Note: The Delany–Bazley constants are valid for values of $X = \rho_f f / R_f$ up to $X \approx 1$. The frequency limit of 2800 Hz gives a value of $X = 2.36$, meaning this is at the upper limit of validity. Other variants of the Delany–Bazley–Miki model are built into the Acoustics Module; these have different validity regions or are used for other fibrous materials. For example, the Miki constants can be selected, they extend the region of applicability of the model in the low X limit, as compared to the Delany–Bazley constants.

Boundary Conditions

- At the solid boundaries, which are the outer walls of the resonator chamber and the pipes, the model uses sound hard (wall) boundary conditions. The condition imposes that the normal velocity at the boundary is zero.
- The model uses port boundary conditions to model the inlet and outlet of the muffler. In waveguides, the port conditions are superior to radiation condition as they can capture complex wave fields that involve several propagating modes. In this model, only plane waves propagation is considered. This means that only one port condition needs to be added at each end. The port uses a plane wave (0,0) mode. If the analysis is carried out above the cutoff frequency of the first nonplane mode (above 2540 Hz), then simply add more port conditions at the inlet and outlet to capture these modes. Note that each port condition generates a postprocessing variable that defines the cutoff frequency of its mode; for example, for Port 1 the variable is `acpr.port1.fc`. The plane wave cutoff frequency is of course 0 Hz.

Results and Discussion

The pressure distribution in the absorptive muffler without the lining material is shown in [Figure 11](#) for the frequency $f = 2800$ Hz. From the figure, it is seen that

at this frequency not only longitudinal standing waves exist but also transverse modes are present.

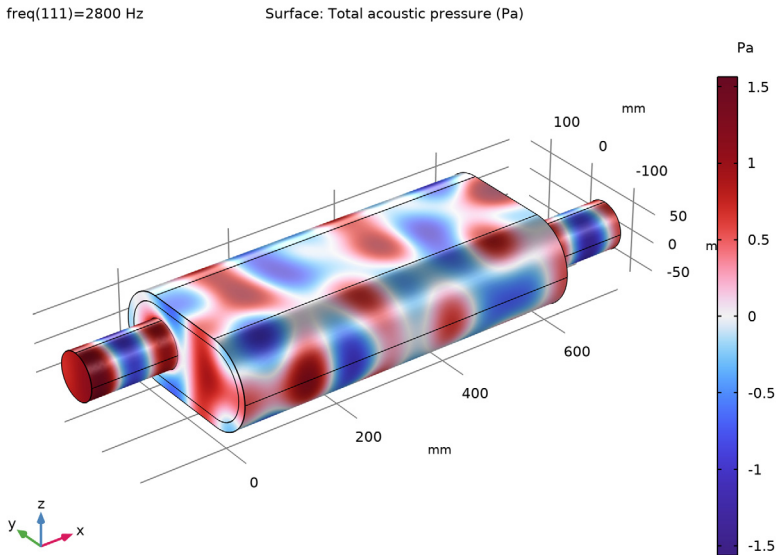

Figure 11: The pressure distribution in the absorptive muffler without the liner is shown for $f = 2800$ Hz.

An important parameter for a muffler is the transmission loss or attenuation. It is defined as the ratio between the incoming and outgoing acoustic energy. The attenuation or transmission loss L (in dB) of the acoustic energy is defined by

$$L = 10 \log \left(\frac{P_{\text{in}}}{P_{\text{out}}} \right)$$

Here P_{in} and P_{out} denote the incoming power at the inlet and the outgoing power at the outlet, respectively. These values are readily derived from the port boundary variables as `acpr.port1.P_in`, and the sum of `acpr.port4.P_out`, `acpr.port5.P_out`, and `acpr.port6.P_out` (the 3 ports at the outlet). These variables can be directly used in postprocessing.

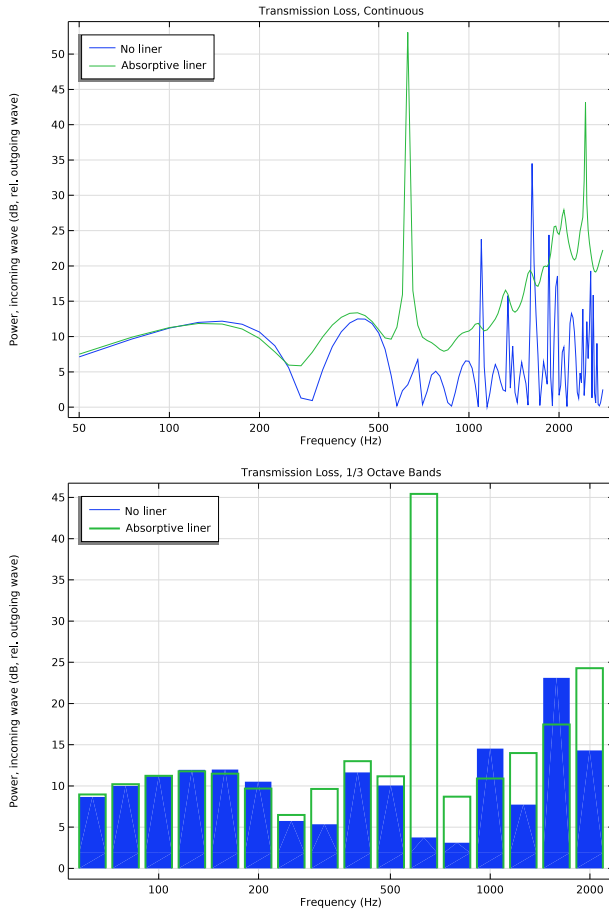

Figure 12: Comparison of the transmission loss as function of frequency for the empty muffler and the muffler with absorptive lining. (top) The transmission loss depicted as a continuous curve, and (bottom) The same data but depicted in 1/3 octave bands.

Figure 12 (top and bottom) shows the result of a parametric frequency study. The two graphs represent the case of an empty muffler without any absorbing lining material (blue lines) and the case with a layer of glass wool lining on the chamber's walls (green lines). The first four dips are due to longitudinal resonances. In the muffler with absorbing lining, the dips are still present, but the general trend is that the higher the frequency, the better the damping. In the top figure, the transmission loss is depicted as a continuous curve (pure tone sweep) while it is

depicted in 1/3 octave bands in the bottom figure. Both graphs are created using the Octave Band Plot of the Acoustics Module.

The graph for the undamped muffler shows that damping works rather well for most low frequencies. At frequencies higher than approximately 1250 Hz, the plot's behavior is more complicated and there is generally less damping. This is because the tube supports not only longitudinal resonances but also cross-sectional propagating modes, for such frequencies. Not very far above this frequency a whole range of modes that are combinations of this propagating mode and the longitudinal modes participate, making the damping properties increasingly unpredictable. For an analysis of these modes, see the related model *Eigenmodes in a Muffler*. The glass-wool lining improves attenuation at the resonance frequencies as well as at higher frequencies.

The flow of energy in the muffler without the liner is shown in [Figure 13](#) at 2800 Hz. The plot represents the intensity field depicted as streamlines. The intensity field is per definition the time average of the energy flux (instantaneous intensity) and thus represents the average energy flow in the system: here from the inlet to the outlet. Change between solutions and frequencies to study and visualize the sound-absorbing properties of the muffler.

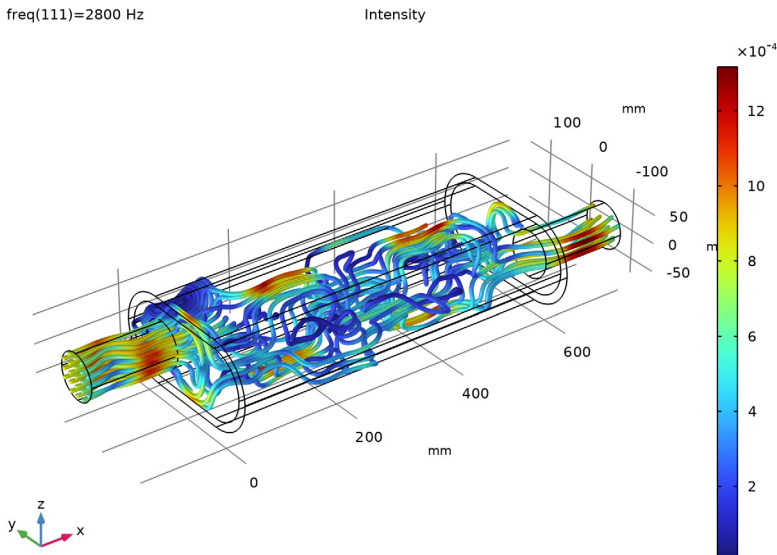

Figure 13: Intensity streamlines at 2800 Hz without the liner.

References

1. M.A. Delany and E.N. Bazley, “Acoustic Properties of Fibrous Absorbent Materials,” *Appl. Acoust.*, vol. 3, pp. 105–116, 1970.
2. D.A. Bies and C.H. Hansen, “Flow Resistance Information for Acoustical Design,” *Appl. Acoust.*, vol. 13, pp. 357–391, 1980.
3. T.J. Cox and P. D’Antonio, *Acoustic Absorbers and Diffusers*, Second Edition, Taylor and Francis, 2009.

Step-by-Step Instructions



The first part of the model instructions (below) describe how to set up and postprocess the Absorptive Muffler model followed by the [Geometry Sequence Instructions](#) section where the geometry is set up; for simplicity, the geometry sequence is imported in the model instructions.

Model Wizard



The instructions take you through two versions of the model, first with a completely hollow chamber with rigid walls, then where the chamber is lined with glass wool.



Note: These instructions are for the user interface on Windows but apply, with minor differences, also to Linux and Mac.

- 1 To start the software, double-click the COMSOL icon on the desktop. When the software opens, you can choose to use the Model Wizard to create a new COMSOL model or Blank Model to create one manually. For this tutorial, click the Model Wizard button.

If COMSOL is already open, you can start the Model Wizard by selecting New  from the File menu and then click Model Wizard .

The Model Wizard guides you through the first steps of setting up a model. The next window lets you select the dimension of the modeling space.



- 2 In the Space Dimension window click the 3D button .
- 3 In the Select Physics tree under Acoustics > Pressure Acoustics, click Pressure Acoustics, Frequency Domain (acpr) . To add the physics interface, double-click it, click Add, or right-click and select  Add Physics.

- 4 Click Study .
- 5 On the Select Study window under General Studies, click Frequency Domain .
- 6 Click Done .

Global Definitions

Note: The location of the text files used in this exercise vary based on the installation. For example, if the installation is on your hard drive, the file path might be similar to C:\Program Files\COMSOL\COMSOL64\applications\.

Parameters

- 1 In the Home toolbar click Parameters  and select Parameter 1 .

Note: On Linux and Mac, the Home toolbar refers to the specific set of controls near the top of the Desktop.

- 2 Go to the Settings window for Parameters. Under Parameters click Load from File .
- 3 Browse to the application library folder (Acoustics_Module\Automotive) and double-click the file absorptive_muffler_parameters.txt.

The parameters define the physical values of the system. The figure below shows the full list of parameters after the import of the geometry sequence (next modeling step). In this process the parameters that define the geometry are added to the list.

Settings
Parameters

Label: Parameters 1

Parameters

Name	Expression	Value	Description
fmax	2800[Hz]	2800 Hz	Maximum study frequency
p_in	1[Pa]	1 Pa	Amplitude of incoming pressure wave
rho_ap	12[kg/m^3]	12 kg/m ³	Apparent density of glass wool
d_av	10[um]	1E-5 m	Mean fiber diameter
R_f	$3.18e-9[N^*s/m^2]*(rho_ap/1[kg/m^3])^1.53/d_av^2$	1424.2 kg/(m ³ ...)	Flow resistivity
T0	20[degC]	293.15 K	Ambient temperature
p0	1[atm]	1.0133E5 Pa	Ambient pressure
L	600[mm]	0.6 m	Muffler length
H	150[mm]	0.15 m	Muffler height
W	300[mm]	0.3 m	Muffler width
L_io	150[mm]	0.15 m	Inlet and outlet length
R_io	40[mm]	0.04 m	Inlet and outlet radius
D	15[mm]	0.015 m	Liner thickness
d_center	60[mm]	0.06 m	Distance of the inlet and outlet to the center of the muffler

Geometry 1

- 1 In the Model Builder window, under Component 1 (comp1) click Geometry 1.
- 2 In the Settings window for Geometry, locate the Units section.
- 3 From the Length unit list, choose mm.

To save some time, import the geometry sequence from a file. The instructions for setting up the geometry can be found in the Geometry Sequence Instructions section at the bottom of this document.

- 1 In the Geometry toolbar, click Insert Sequence.
- 2 Browse to the model's Application Libraries folder and double-click the file absorptive_muffler_geom_sequence.mph.

3 In the Geometry toolbar, click Build All.

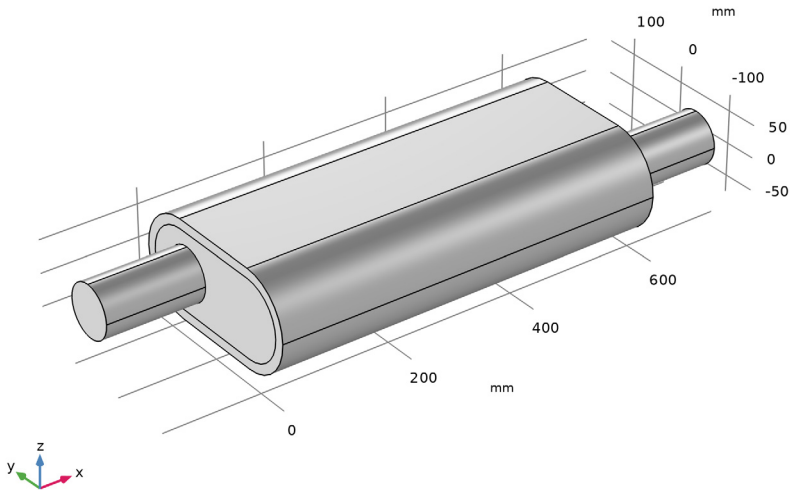

Having imported the geometry it can be easily modified as it is parameterized. Simply change the value of a dimension in the parameters list; this will update the geometry automatically. The imported geometry parameters are automatically added to the Parameters 1 node.

Definitions

Create selections for the inlet and outlet of the muffler.

Explicit 1

- 1 In the Definitions toolbar click Explicit .
- 2 Go to the Settings window for Explicit. Enter Inlet in the Label field (replace the default).
- 3 Under Input Entities from the Geometric entity level list, choose Boundary.
- 4 Select Boundary 1 only.



Explicit 2

- 1 In the Definitions toolbar click Explicit .

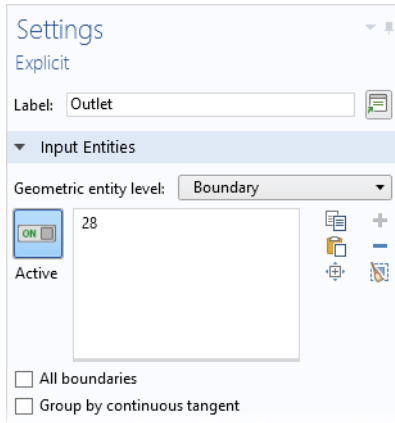
- 2 Go to the Settings window for Explicit. Enter Out1et in the Label field (replace the default).
- 3 Under Input Entities from the Geometric entity level list, choose Boundary.
- 4 Select Boundary 28 only.



Add Material

- 1 In the Home toolbar click Add Material .
- 2 Go to the Add Material window. In the tree under Built-In click Air .
- 3 In the Add material window, click + Add to Component.
- 4 Under Materials click Air  to look at the Material Contents in the Settings window.

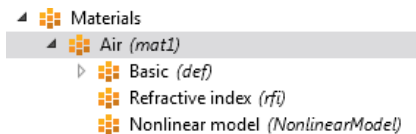
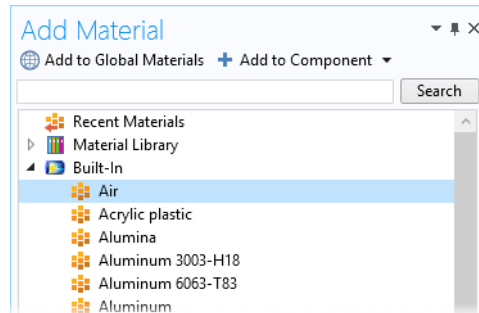

The green check marks indicate which material parameters are necessary in the model.

Material Contents					
Property	Variable	Value	Unit	Property group	
<input checked="" type="checkbox"/> Density	rho	rho(pA,T)	kg/m ³	Basic	
<input checked="" type="checkbox"/> Speed of sound	c	cs(T)	m/s	Basic	
Coefficient of thermal expansion	alpha_iso ; a...	alpha_p(pA,T)	1/K	Basic	
Mean molar mass	Mn	0.02897	kg/mol	Basic	
Bulk viscosity	muB	muB(T)	Pa·s	Basic	
Relative permeability	mur_iso ; m...	1	1	Basic	
Relative permittivity	epsilon_r_iso...	1	1	Basic	
Dynamic viscosity	mu	eta(T)	Pa·s	Basic	
Ratio of specific heats	gamma	1.4	1	Basic	

Note: By default the first material added applies to all domains so the geometric scope settings do not need to be changed.

In the second version of this model, a lining material is needed in Domain 2. For now, the muffler is completely hollow. The liner material is added here.

Materials

ABSORPTIVE LINER

- 1 In the Model Builder window, under Component 1 (comp1) right-click Materials and choose Blank Material.
- 2 In the Settings window for Material, type Absorptive Liner in the Label text field.

Pressure Acoustics, Frequency Domain

Pressure Acoustics 1

- 1 In the Model Builder window, under Component 1 (comp1) > Pressure Acoustics, Frequency Domain (acpr) click Pressure Acoustics 1.
- 2 In the Settings window for Pressure Acoustics, locate the Model Input section.
- 3 In the T text field, type τ_0 .
- 4 In the pA text field, type p_0 .

Use the Port boundary condition to define the inlet and outlet. The port condition is superior to the classical radiation condition in waveguide configurations. This is particularly the case when nonplane wave modes start to propagate. This happens above the first cutoff frequency. For the present model the cutoff frequency for the first nonplane mode ($m = 1$ and $n = 0$) is at 2514 Hz so this mode should be included. The variable `acpr.port2.fc` gives the cutoff frequency of the modes (here for the mode defined on the Port 2 condition).

Note that when including an azimuthal mode in a circular port, it is necessary to add both possible azimuthal angle dependencies (sine and cosine), each as a different Port condition. To get a complete basis for the modal expansion at the boundary, both the sine and cosine variants of the mode need to be included, as these modes are orthogonal.

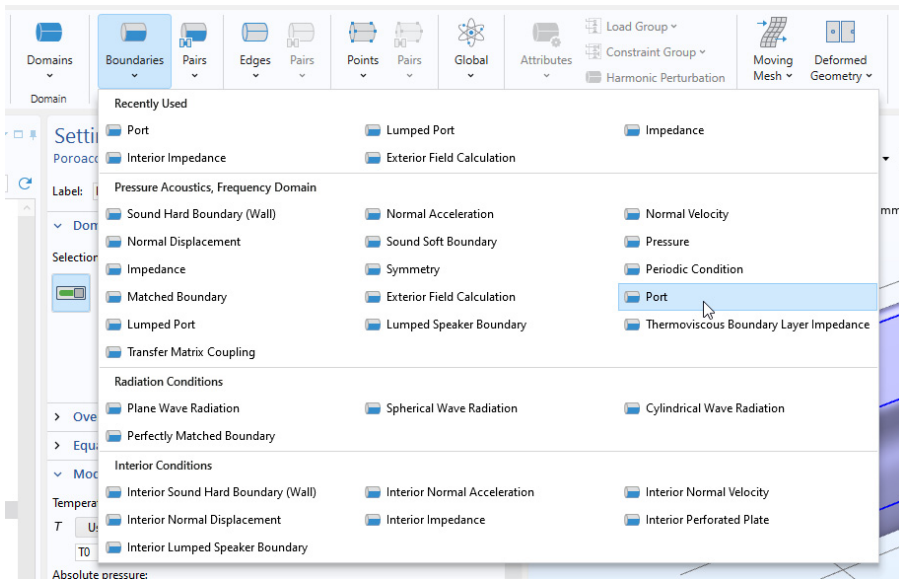

Port 1

- 1 In the Physics toolbar, click Boundaries and choose Port.
- 2 In the Settings window for Port, locate the Boundary Selection section.

- 3 From the Selection list, choose Inlet.
- 4 Locate the Port Properties section. From the Type of port list, choose Circular.
- 5 Locate the Incident Mode Settings section. In the A^{in} text field, type p_{in} .

Circular Port Reference Axis 1

- 1 Right-click Port 1 and choose Circular Port Reference Axis, under the Points submenu.
- 2 In the Settings window for Circular Port Reference Axis, locate the Point Selection section.
- 3 Click Clear Selection.
- 4 Select Points 1 and 4 only.
Select two points that define a reference axis for the azimuthal angle. The setting is in general necessary when higher order azimuthal modes are used and/or necessary.

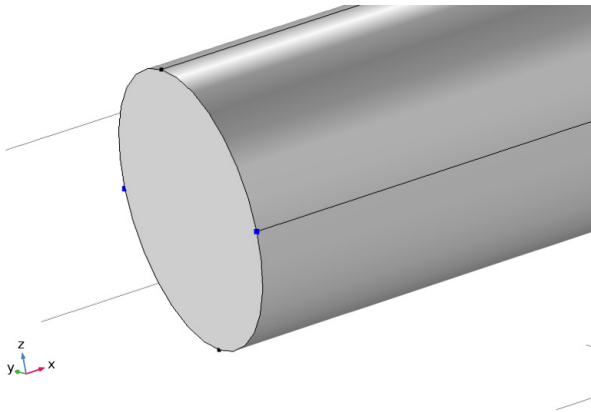

Port 2

- 1 In the Model Builder window, under Component 1 (comp1) > Pressure Acoustics,
- 2 Frequency Domain (acpr) right-click Port 1 and choose Duplicate.

- 3 In the Settings window for Port, locate the Port Mode Settings section. In the m text field, type 1.
- 4 Locate the Incident Mode Settings section. From the Incident wave excitation at this port list, choose Off.

Port 3

- 1 Right-click Port 2 and choose Duplicate.
- 2 In the Settings window for Port, locate the Port Mode Settings section.
- 3 From the Azimuthal angle dependency list, choose Cosine.

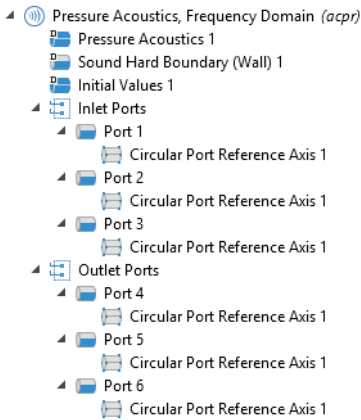

Proceed to add three port conditions also on the Outlet boundary with the same properties as the inlet ports. One mode (0,0) and two mode (1,0) with the two different Azimuthal angle dependency options, Sine and Cosine. All the ports at the outlet have the Incident wave excitation set to Off.

Then group the ports by selecting the three Ports, right click and select Group. This step is only for organizing the user interface.



Now, add a Poroacoustics model for the absorptive liner domain. You will deactivate this domain when configuring the first study step.

Poroacoustics

- 1 In the Physics toolbar click Domains  and choose Poroacoustics .
- 2 Go to the Settings window for Poroacoustics. Select Domain 2 only.
- 3 In the Settings window for Poroacoustics, locate the Model Input section.
- 4 In the T text field, type T_0 .

- 5 Locate the Porous Matrix Properties section. From the Porous elastic material list, choose Absorptive Liner (mat2).

The material data for the flow resistivity will now be picked up from the Absorptive Liner material. Enter the data in the material.

Materials

Absorptive Liner (mat2)

- 1 In the Model Builder window, under Component 1 (comp1) > Materials click Absorptive Liner (mat2).
- 2 In the Settings window for Material, locate the Material Contents section.
- 3 In the table, enter the following settings:

PROPERTY	VARIABLE	VALUE	UNIT	PROPERTY GROUP
Flow resistivity	Rf_jso	R_f	Pa·s/m ²	Poroacoustics model

Mesh 1

Proceed and generate the mesh using the Physics-controlled mesh functionality. In general, 5 to 6 second-order elements per wavelength are needed to resolve the waves. For more details see the *Acoustics Module User's Guide*. In this model we use the default Automatic option, which gives 5 elements per wavelength.

- 1 In the Model Builder window, under Component 1 (comp1) click Mesh 1.
- 2 In the Settings window for Mesh, locate the Pressure Acoustics, Frequency Domain (acpr) section.
- 3 From the Maximum mesh element size control parameter list, choose Frequency.

4 In the Maximum frequency text field, type f_{\max} .

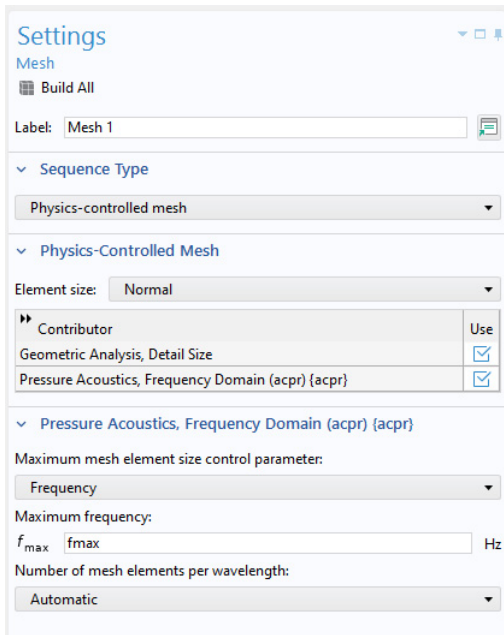

The screenshot shows the 'Settings' dialog box for a mesh. The 'Label' is 'Mesh 1'. The 'Sequence Type' is 'Physics-controlled mesh'. Under 'Physics-Controlled Mesh', the 'Element size' is 'Normal'. A table lists contributors with checkboxes for use:

Contributor	Use
Geometric Analysis, Detail Size	<input checked="" type="checkbox"/>
Pressure Acoustics, Frequency Domain (acpr) {acpr}	<input checked="" type="checkbox"/>

Under 'Pressure Acoustics, Frequency Domain (acpr) {acpr}', the 'Maximum mesh element size control parameter' is 'Frequency'. The 'Maximum frequency' is set to f_{\max} Hz. The 'Number of mesh elements per wavelength' is 'Automatic'.



5 Click the Build All button  .

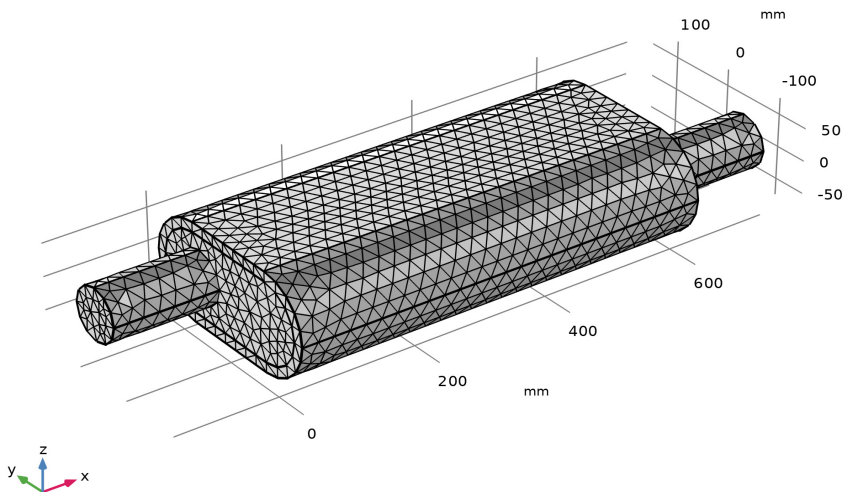

The mesh should look like the image below.



Study 1

Step 1: Frequency Domain

- 1 In the Model Builder expand the Study 1 node then click Step 1: Frequency Domain .
- 2 Go to the Settings window for Frequency Domain. Under Study Settings in the Frequencies text field, enter range (50, 25, fmax). The list can be generated by selecting the Range button , setting Start to 50, Step to 25, and Stop to fmax, then click Replace.

- 3 Locate the Physics and Variables Selection section. Select the Modify model configuration for study step checkbox.
- 4 In the tree, under Component 1 > Pressure Acoustics, Frequency Domain, click Poroacoustics 1.
- 5 Click the Disable button  under the table.
- 6 In the Settings window or Home toolbar click Compute  .

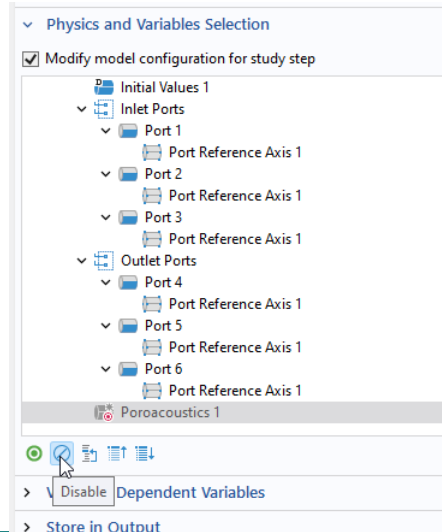

Results

The first default plot shows the pressure distribution on the walls of the muffler at the highest frequency, 2800 Hz.



Acoustic Pressure (acpr)

freq(111)=2800 Hz

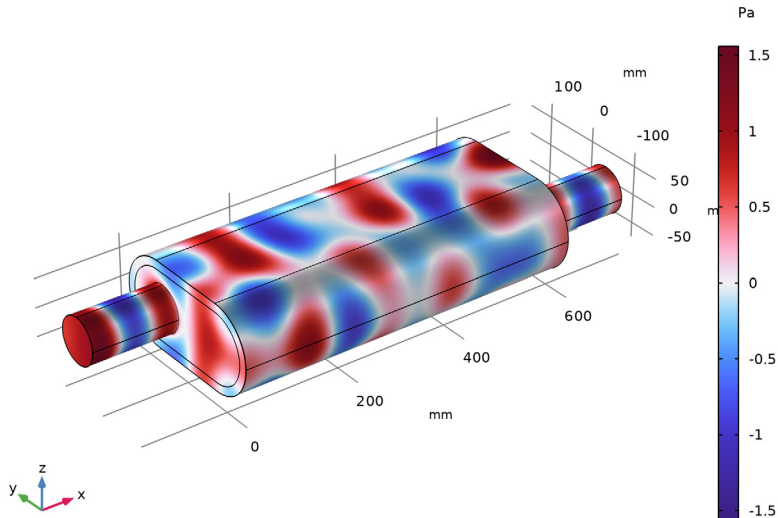
Total acoustic pressure (Pa)



The pattern is very different at different frequencies. See for example what happens at 1250 Hz.

- 1 In the Model Builder under Results, click Acoustic Pressure (acpr) .
- 2 Go to the Settings window for 3D Plot Group. Under Data from the Parameter value (freq) list, choose 1250.0.
- 3 On the 3D Plot Group toolbar click the Plot button .

At 1250 Hz, the absolute value of the pressure does not vary much with the x-coordinate. The reason is that this is just higher than the cutoff frequency for the first symmetric propagating mode, which is excited by the incoming wave. For a separate analysis of the propagating modes in the chamber, see the description for the [Eigenmodes in a Muffler](#) model.

The two other default plot groups show the sound pressure level on the wall surface and the pressure inside the muffler as isosurfaces.

Acoustic Pressure, Isosurfaces (acpr)

- 1 In the Model Builder under Acoustic Pressure, Isosurfaces (acpr), click the Isosurface node  to display the plot in the next figure.

freq(111)=2800 Hz

Isosurface: Total acoustic pressure (Pa)

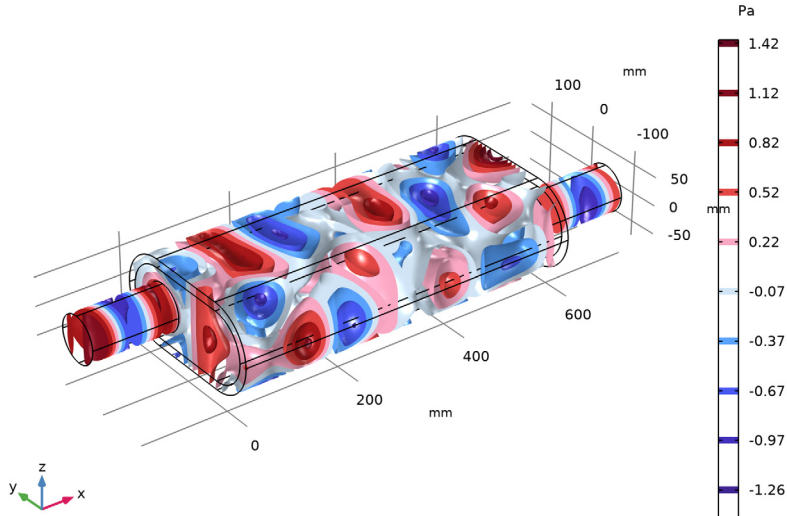

Proceed to plot the transmission loss of the muffler system. Use the Octave Band Plot as it allows to plot any transfer function both as band plots and as continuous curves (sweeps).

1D Plot Group 4

- 1 In the Home toolbar, click Add Plot Group and choose 1D Plot Group .
- 2 In the Settings window for 1D Plot Group, type Transmission Loss, Continuous in the Label text field.

Transmission Loss, Continuous

- 1 On the Transmission Loss, Continuous toolbar, select Octave Band under More plots, click Octave Band Plot .
- 2 In the Settings window for Octave Band Plot, locate the Selection section.
- 3 From the Geometric entity level list, choose Global.

Start by locating and inspecting the postprocessing variables available for the port boundary conditions. Add the variable for the power of the incident mode at Port 1. Then modify the expression manually to get the ratio to the power of all the outgoing modes at Port 4, 5, and 6. This will give the transmission loss.

- 4 In the upper-right corner of the y-axis data section, click Replace Expression . From the menu, choose Component 1 > Pressure Acoustics, Frequency Domain > Ports > Port 1 > acpr.port1.P_in - Power of incident mode - W.
- 5 Locate the y-Axis Data section. In the Expression text field, type acpr.port1.P_in/(acpr.port4.P_out+acpr.port5.P_out+acpr.port6.P_out).

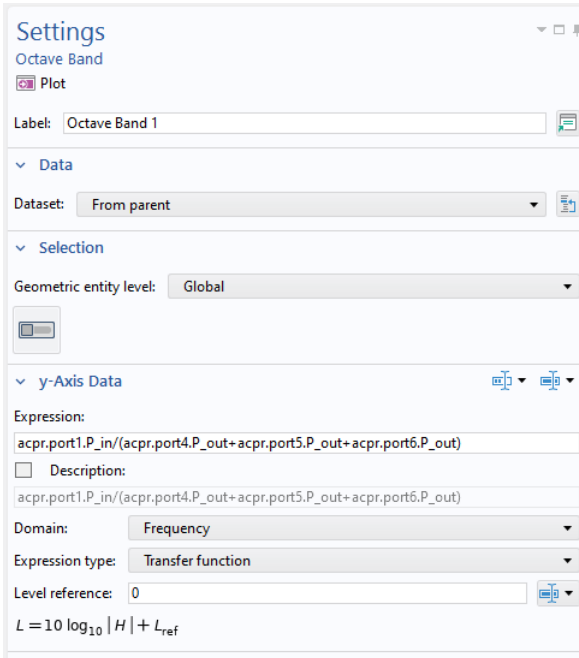

- 6 From the Expression type list, choose Transfer function.
- 7 Locate the Plot section. From the Style list, choose Continuous.
- 8 Locate the Legends section. Select the Show legends checkbox.
- 9 From the Legends list, choose Manual.
- 10 In the table, enter the following settings:



LEGENDS
No liner

- 11 On the Transmission Loss, Continuous toolbar, click Plot .

The plot should be a reproduction of the blue curve in [Figure 12](#).

Model Wizard

Proceed to solve the model including a layer of absorptive glass wool on the muffler line. Continue working from where you left off with the model developed thus far and add a second study to keep your existing results intact. The first task is to add a second study to keep the existing results intact.

- 1 In the Home toolbar click Add Study .
- 2 Go to the Add Study window. Under Studies click Frequency Domain . Click Add Study . A Study 2 node is added to the Model Builder.

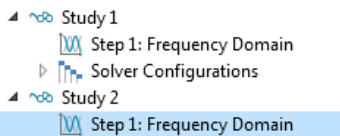

- 3 In the Home toolbar, click Add Study to close the Add Study window.

Study 2

- 1 In the Model Builder click Study 2 .
- 2 In the Settings window for Study under the Study Settings section, click to clear the Generate default plots checkbox.

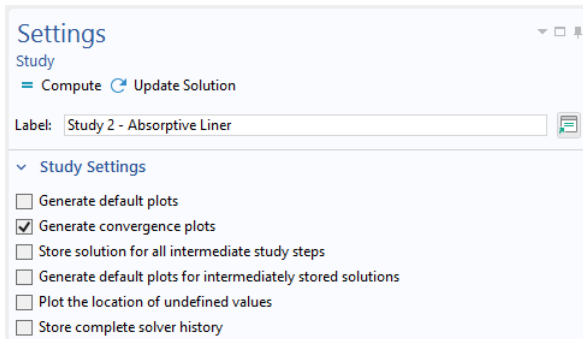

Step 1: Frequency Domain

- 1 Under Study 2 click Step 1: Frequency Domain .
- 2 In the Settings window for Frequency Domain locate the Study Settings section.

3 In the Frequencies text field enter range(50,25,fmax) .

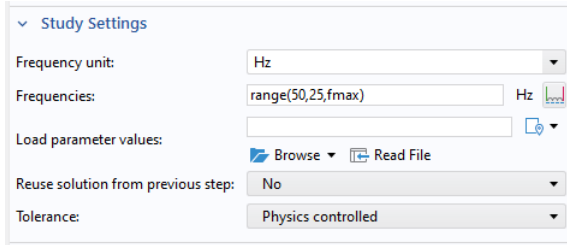

4 In the Settings window or Home toolbar click Compute = .

Results

You chose not to have new default plots generated. Once the solution process is finished you can use the existing plot groups and just switch the dataset to see how the damping material affects the solution.

Acoustic Pressure, Isosurfaces (acpr)

1 In the Model Builder under Results, click the Acoustic Pressure, Isosurfaces (acpr) node.

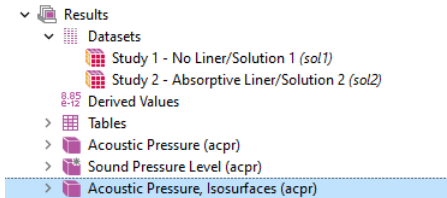

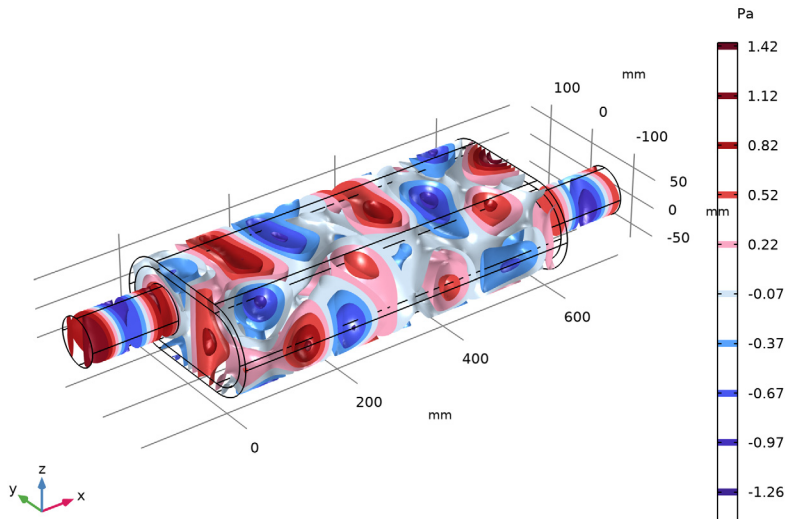

freq(111)=2800 Hz

Isosurface: Total acoustic pressure (Pa)

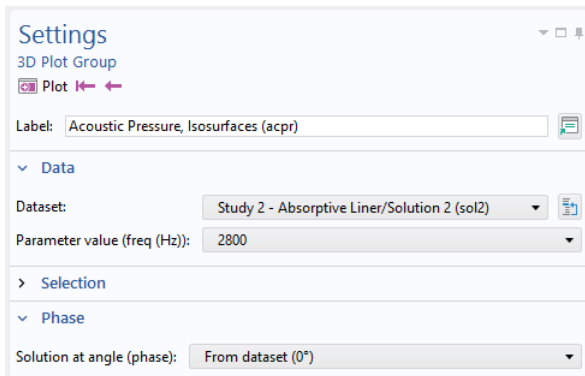

- 2 In the Settings window for 3D Plot Group under Data, from the Dataset list choose Study2/Solution 2.



- 3 In the Settings window click the Plot button .

At 2800 Hz, the pressure in the chamber is much lower than before.

Proceed to study how the transmission loss has changed with the addition of the lining. Duplicate the first plot and select the new dataset, first do a bit of formatting.

Transmission Loss, Continuous

- 1 In the Model Builder window, under Results click Transmission Loss, Continuous.
- 2 In the Settings window for 1D Plot Group, click to expand the Title section.
- 3 From the Title type list, choose Manual.
- 4 In the Title text area, type Transmission Loss, Continuous.
- 5 Locate the Plot Settings section. Select the y-axis label checkbox.
- 6 In the associated text field, type Power, incoming wave (dB, rel. outgoing wave).
- 7 Click to expand the Legend section. From the Position list, choose Upper left.
- 8 In the Model Builder window, under Results > Transmission Loss, Continuous right-click Octave Band Plot 1 and choose Duplicate.
- 9 In the Settings window for Octave Band Plot, locate the Data section.
- 10 From the Dataset list, choose Study 2/Solution 2 (sol2).
- 11 Click to expand the Legends section. In the table, enter the following settings:

LEGENDS

Absorptive liner

- 12 On the Transmission Loss, Continuous toolbar, click Plot  .

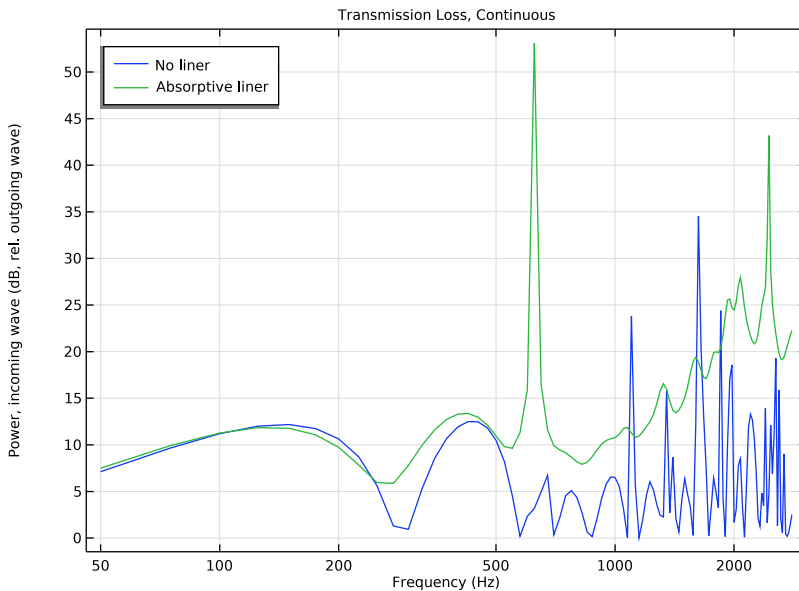

The plot should look like that in [Figure 12](#) top.

Duplicate the Transmission Loss plot and change the format to 1/3 octave bands.

Transmission Loss, Continuous 1

- 1 In the Model Builder window, right-click Transmission Loss, Continuous and choose Duplicate.
- 2 In the Settings window for 1D Plot Group, type Transmission Loss, 1/3 Octave Bands in the Label text field.
- 3 Locate the Title section. In the Title text area, type Transmission Loss, 1/3 Octave Bands.

Transmission Loss, 1/3 Octave Bands

- 1 In the Model Builder window, expand the Results > Transmission Loss, 1/3 Octave Bands node, then click Octave Band Plot 1.
- 2 In the Settings window for Octave Band Plot, locate the Plot section.
- 3 From the Quantity list, choose Band average power spectral density
- 4 From the Band type list, choose 1/3 octave bands.

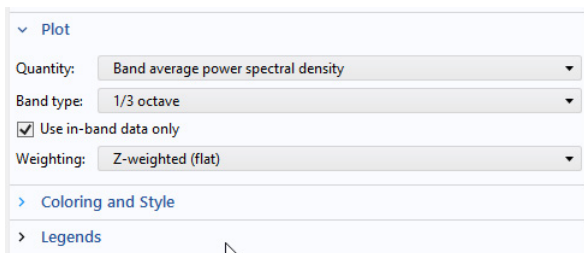

- 5 In the Model Builder window, under Results > Transmission Loss, 1/3 Octave Bands click Octave Band Plot 2.
- 6 In the Settings window for Octave Band Plot, locate the Plot section.
- 7 From the now Band type list, choose 1/3 octave bands.
- 8 Locate the Coloring and Style section, then click to expand the Coloring and style section. From the Type list, choose Outline.
- 9 In the Width text field, type 2.

10 On the Transmission Loss, 1/3 Octave Bands toolbar, click Plot .

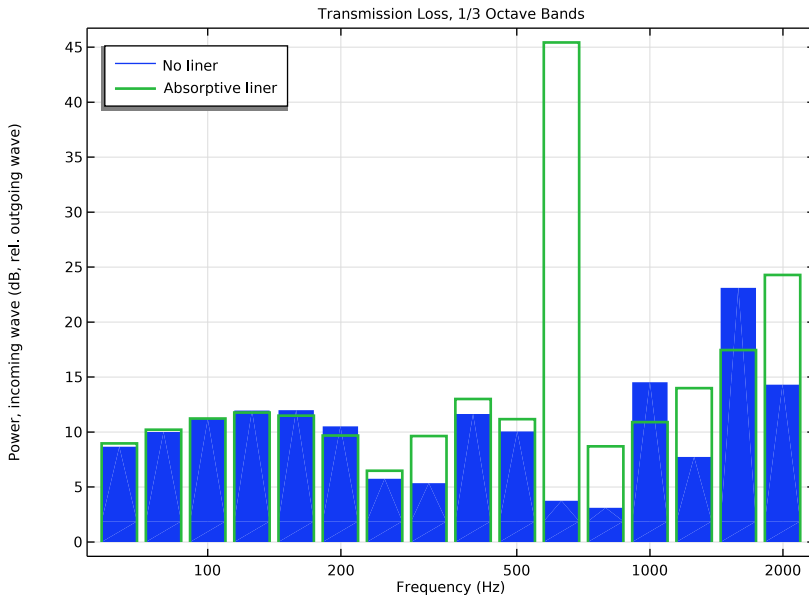



The plot should look like that in [Figure 12](#) bottom.

Now, create a plot that represents the intensity flux through the muffler system. Use streamlines that follow the intensity vector (flux of energy through the muffler). You can change between solutions and frequencies to study and visualize the muffler's sound-absorbing properties.

Intensity

Intensity

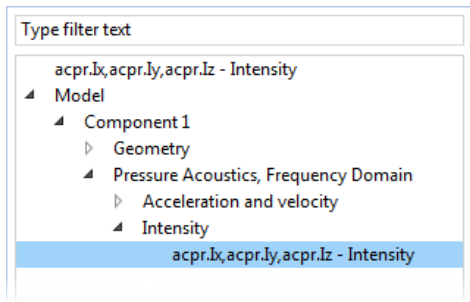

- 1 In the Results toolbar click 3D Plot Group .
- 2 In the Settings window for 3D Plot Group 5, enter Intensity in the Label text field.
- 3 In the Intensity toolbar click Streamline .
- 4 In the Settings window for Streamline click the Replace Expression  button.

- 5 From the menu, search for Intensity (RMS) or $acpr.I_x, acpr.I_y, acpr.I_z$. Double-click to add it to the Expression text field (or enter $acpr.I_x, acpr.I_y, acpr.I_z$ in the field).

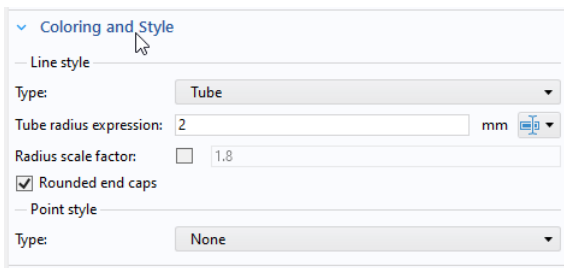

- 6 Under Selection select Boundary 1 only to add it to the selection list.
- 7 Under Coloring and Style:
- From the Line type list choose Tube.
 - In the Tube radius expression text field enter 2.



- 8 In the Model Builder under Intensity, right-click Streamline 1  and choose Color Expression .
- 9 In the Settings window for Color Expression enter $acpr.I_{rms}$ in the Expression text field (replace the default).

10 In the Settings window click Plot  .

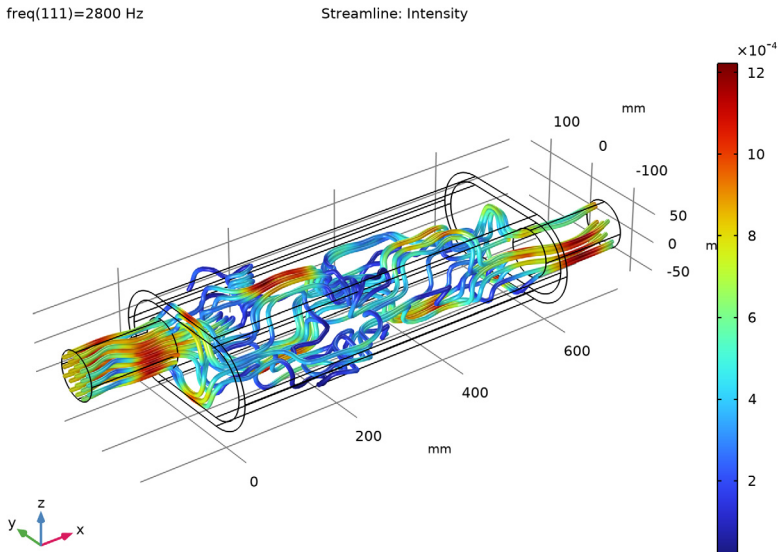

This should reproduce [Figure 13](#).

As a final step, pick one of the plots to use as a model thumbnail.

1 In the Model Builder under Results, click Acoustic Pressure, Isosurfaces  .



2 Click the Root node (the first node in the model tree). In the Settings window for Root under Presentation, click Set from Graphics Window, to set the model Thumbnail.

Make adjustments to the image in the Graphics window using the toolbar buttons until the image is one that is suitable to your purposes.

Geometry Sequence Instructions

Below you find the instructions on how to set up the geometry manually if the geometry has not been imported.

PARAMETERS

- 1 In the Home toolbar click Parameters  and select Parameter 1 .
- Note: On Linux and Mac, the Home toolbar refers to the specific set of controls near the top of the Desktop.
- 2 Go to the Settings window for Parameters. Under Parameters click Load from File .

Browse to the application library folder (Acoustics_Module\Automotive) and double-click the file absorptive_muffler_geom_sequence_parameters.txt.

GEOMETRY

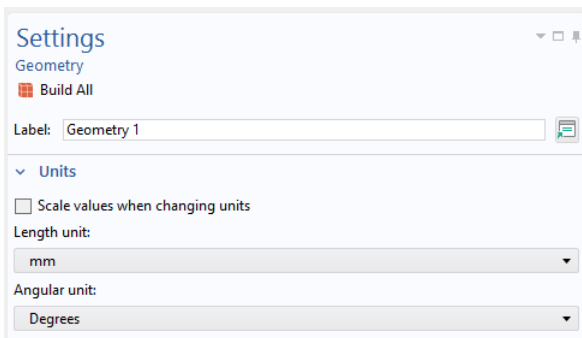

- 1 In the Model Builder under Component 1, click Geometry 1 .
- 2 Go to the Settings window for Geometry. Under Units from the Length unit list, choose mm.



Work Plane 1

- 1 In the Geometry toolbar click Work Plane .
- 2 Go to the Settings window for Work Plane. Under Plane Definition, from the Plane list choose yz-plane.

Rectangle 1

- 1 Right-click Plane Geometry  and add a Rectangle .

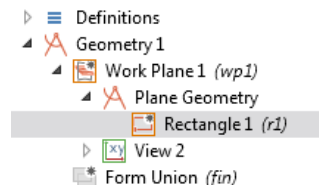

- 2 Go to the Settings window for Rectangle. Under Size in the:
 - Width text field, enter W.
 - Height text field, enter H.
- 3 Locate the Position section. From the Base list, choose Center.

Fillet 1



- 1 On the Work plane toolbar click Fillet  .
- 2 On the object r1, select Points 1, 2, 3, 4 only.

Note: There are many ways to select geometric entities. When you know the points to add, such as in this exercise, you can click the Paste Selection button  and enter the information in the Selection text field. In this example for the Fillet 1 node, enter 1, 2, 3, 4 in the Paste Selection window. For more information about selecting geometric entities in the Graphics window, see the *COMSOL Multiphysics Reference Manual*.

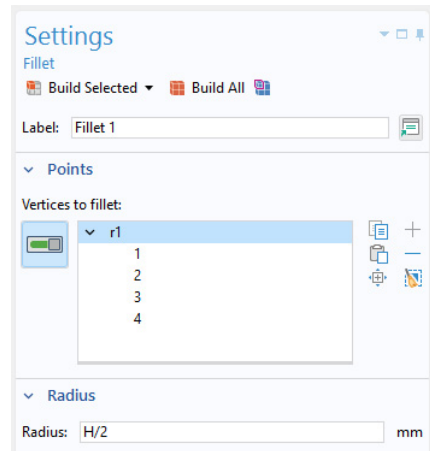
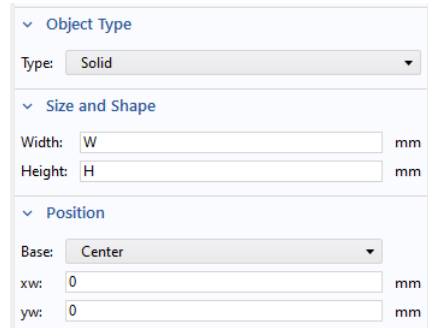
- 3 Go to the Settings window for Fillet. Under Radius in the Radius text field, enter H/2.



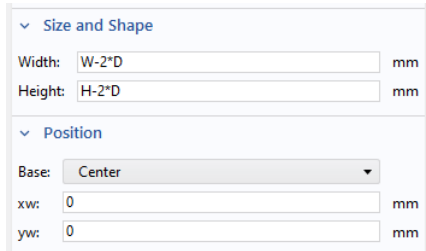

Rectangle 2

- 1 Right-click Plane Geometry  and choose Rectangle .
- 2 Go to the Settings window for Rectangle. Under Size in the:
 - Width text field, enter $W-2*D$.
 - Height text field, enter $H-2*D$.
- 3 Locate the Position section. From the Base list, choose Center.





Fillet 2

- 1 On the Work plane toolbar, click Fillet .
- 2 On the object r2, select Points 1,2,3,4 only.
- 3 Go to the Settings window for Fillet. Under Radius in the Radius text field, enter $(H-2*D)/2$.
- 4 Click the Build All button  in the Settings window or Home toolbar.

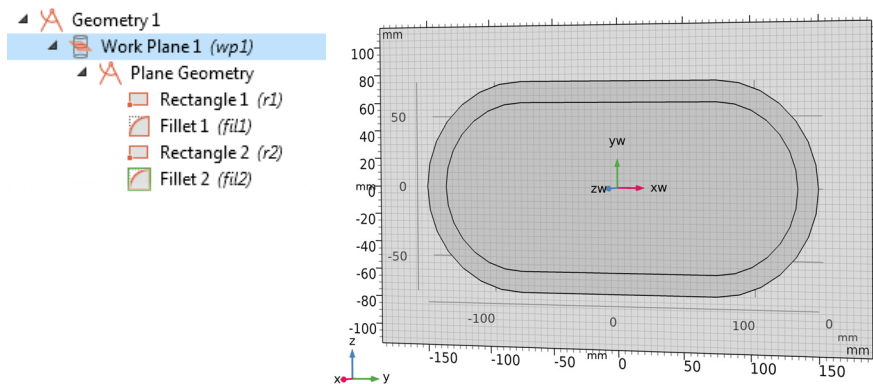
The geometry in the Graphics window and the node sequence under Work Plane 1 should match these figures at this point:



Extrude 1

- 1 On the Work plane toolbar, click Close .
- 2 In the Geometry toolbar click Extrude .

- Go to the Settings window for Extrude. Under Distances from Plane in the table under Distances (mm), enter L in the column (replace the default).

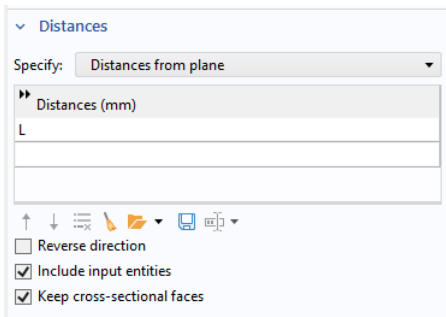

Cylinder 1

- In the Geometry toolbar click Cylinder .
- Go to the Settings window for Cylinder. Under Size and Shape in the:
 - Radius text field, enter R_{io} .
 - Height text field, enter L_{io} .
- Under Position in the x text field, enter $-L_{io}$.
- Under Position in the y text field, enter d_{center} .
- Under Axis:
 - From the Axis type list, choose Cartesian.
 - In the x text field, enter 1.
 - In the z text field, enter 0.

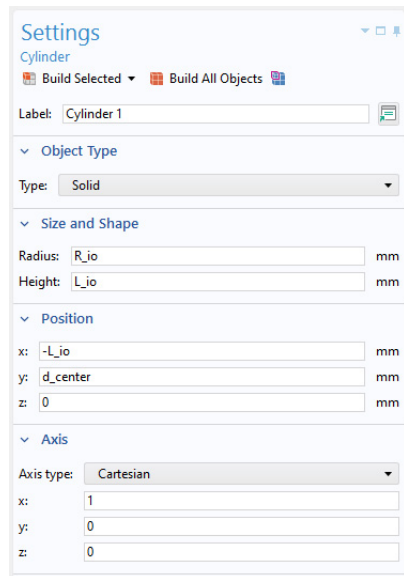



Cylinder 2

- In the Geometry toolbar click Cylinder .
- Go to the Settings window for Cylinder. Under Size and Shape in the:
 - Radius text field, enter R_{io} .
 - Height text field, enter L_{io} .
- Under Position in the x text field, enter L.
- Under Position in the y text field, enter $-d_{center}$.

5 Under Axis:

- From the Axis type list, choose Cartesian.
- In the x text field, enter 1.
- In the z text field, enter 0.

6 Click the Build All button  In the Home toolbar. Click the Zoom Extents button  in the Graphics toolbar.

The node sequence in the Model Builder should match the figure.

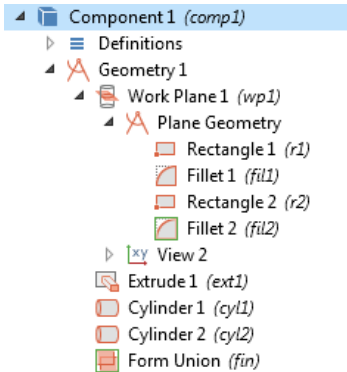

The finished geometry is shown in the figure below, the axis dimensions are in mm, as selected, and the system of coordinates is also shown.

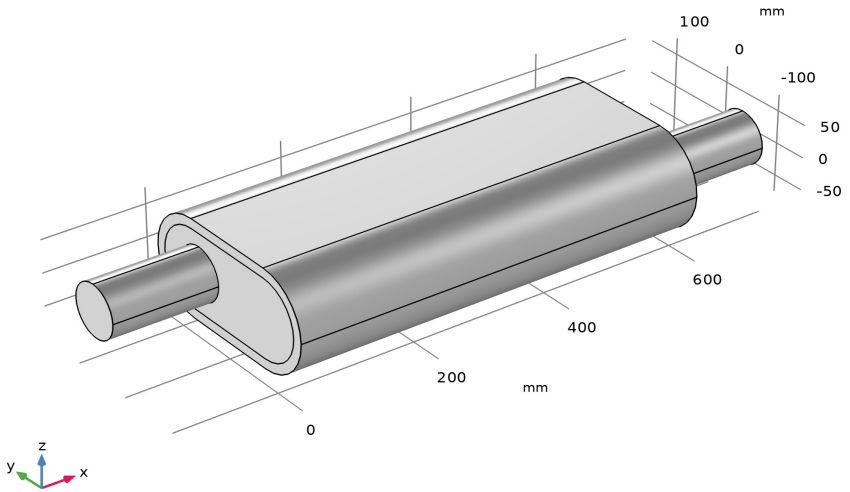

Additional Examples from the Application Libraries

The Acoustics Module application library has other tutorials available as well as advanced industrial and verification models. Short explanations and examples are given below for a cross section of these models. Go to [The Application Libraries Window](#) to learn how to access these model files from COMSOL Multiphysics.

Eigenmodes in a Muffler

In this model, the propagating modes in the chamber of an automotive muffler are computed. The geometry is a cross section of the chamber as described in the Absorptive Muffler example in this guide.

The purpose of the model is to study the shape of the propagating modes and to find the cutoff frequencies. The boundary mode analysis in COMSOL is sometimes referred to as semi-analytical finite element or SAFE. As discussed in the Absorptive Muffler tutorial, some of the modes significantly affect the damping of the muffler at frequencies above the cutoff. In the Eigenmodes in Muffler model, modes with cutoff frequencies up to 1500 Hz are studied.

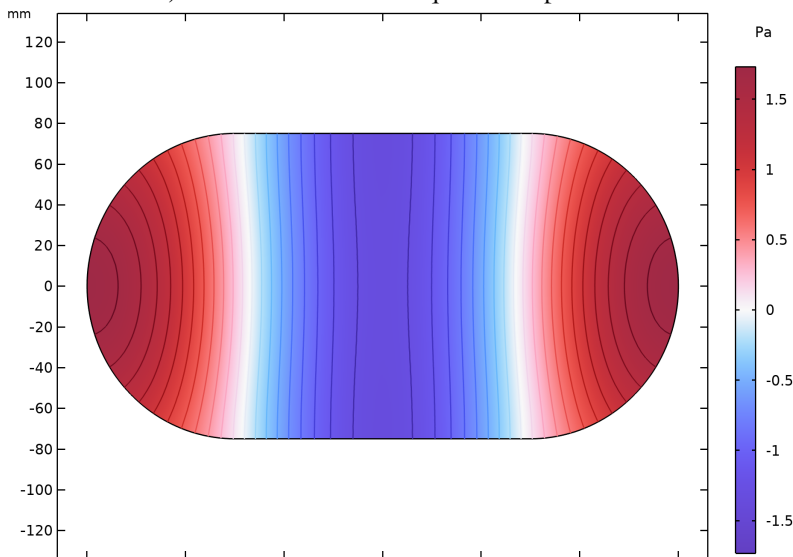

Figure 14: First fully symmetric propagation mode of the muffler chamber (with no absorbing liner). The plot shows the real part of the pressure.

Piezoacoustic Transducer

A piezoelectric transducer can be used either to transform an electric current to an acoustic pressure field or, the opposite, to produce an electric current from an acoustic field. These devices are generally useful for applications that require the generation of sound in air and liquids. Examples of such applications include phased array microphones, ultrasound equipment, inkjet droplet actuators, sonar transducers, and devices for drug discovery, bioimaging, and acousto-biotherapeutics.

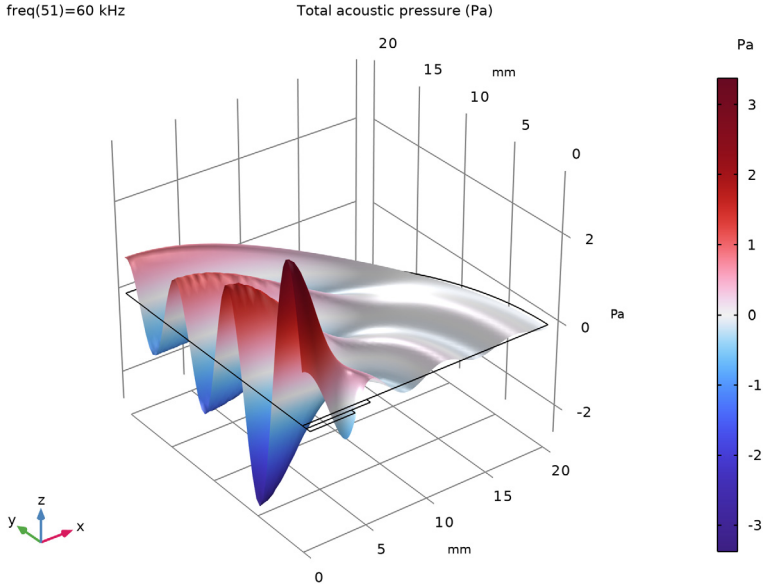

Figure 15: Surface and height plot of the pressure distribution created by the piezoactuator at $f = 60$ kHz.

Loudspeaker Driver in a Vented Enclosure

An important class of acoustic models are transducers — that is, electromechanical acoustic transducers. Transducers are true multiphysics models that often in addition to acoustics necessitate a structural mechanics and an electromagnetic interface is added. One such class are loudspeakers (presented here), another are microphones presented below.

This model of a boxed loudspeaker lets you apply a nominal driving voltage and extract the resulting sound pressure level in the outside room as a function of the frequency, including on-axis response and directivity plots. The electromagnetic properties of the driver are supplied from the Loudspeaker Driver model (available with the AC/DC Module). The model uses the Acoustic-Shell Interaction

interface and therefore requires the Structural Mechanics Module. The model combines acoustics modeled with FEM and BEM, as well as Solid Mechanics for the cabinet and shells for the driver. The structural modes of the speaker are also analyzed.

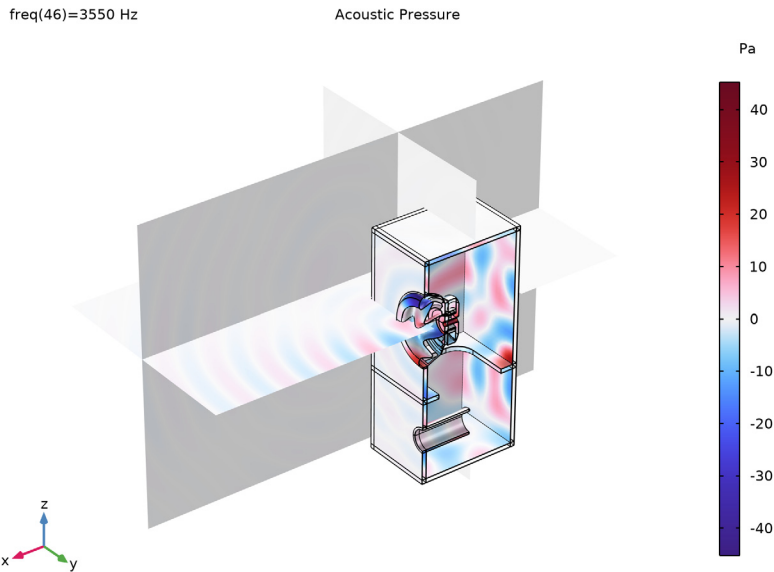

Figure 16: Pressure distribution at 3550 Hz.

The Brüel & Kjær 4134 Condenser Microphone

Another type of transducer is the microphone. This is a model of the Brüel and Kjær 4134 condenser microphone. The geometry and material parameters are those of the microphone. The modeled sensitivity level is compared to measurements performed on an actual microphone and shows good agreement. The membrane deformation, pressure, velocity, and electric field are also

determined. The model requires the Acoustics Module, the AC/DC Module, and the Structural Mechanics Module.

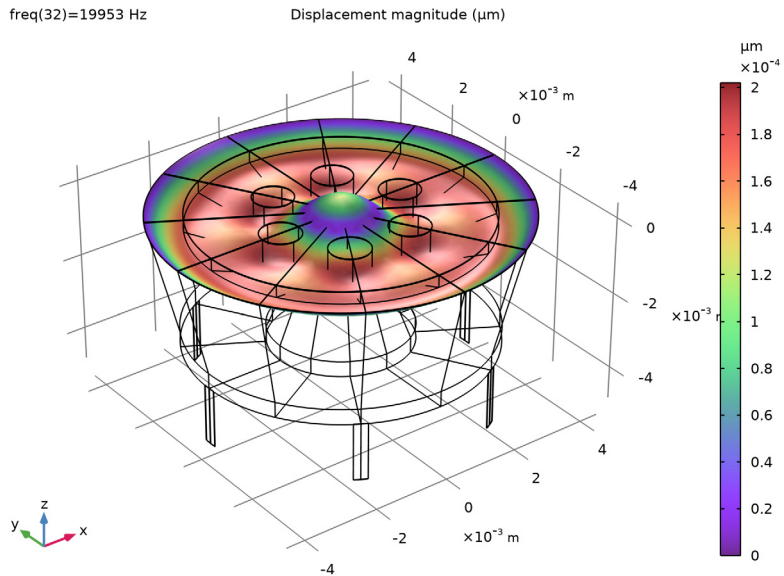

Figure 17: Deformation of the microphone membrane (diaphragm) at 20 kHz. The geometry is courtesy of Brüel & Kjær.

This concludes this introduction.

