



Buckling Analysis of a Truss Tower

Introduction

Trusses are commonly used to create light structures that can support heavy loads. When designing such a structure, it is important to ensure its safety. For a tower made of bars, buckling can cause the structure to collapse. This example shows how to compute the critical buckling load using a linear buckling analysis. The solution is compared with an analytical expression for critical load estimation for Euler buckling.

Then a slight prescribed deformation is applied to the structure, and a stationary study with load increasing up to critical buckling load is performed. This study puts in evidence the singularity at critical buckling load.

Model Definition

The model geometry consists of a 19 m tall truss tower with a rectangular section. The critical buckling load is computed using the linear buckling analysis available in the Truss interface.

The geometry is the periodic structure represented in [Figure 1](#) below. It consists of 19 blocks of trusses. Each block has a width of 0.45 m, a depth of 0.40 m and a height of 1.0 m. The trusses that are perpendicular to the ground are thicker and have an outer radius of 15 mm and an inner radius of 10 mm. The remaining trusses have an outer radius

of 10 mm and an inner radius of 7 mm. The tower is made out of structural steel, which is one of the predefined materials in the material library.

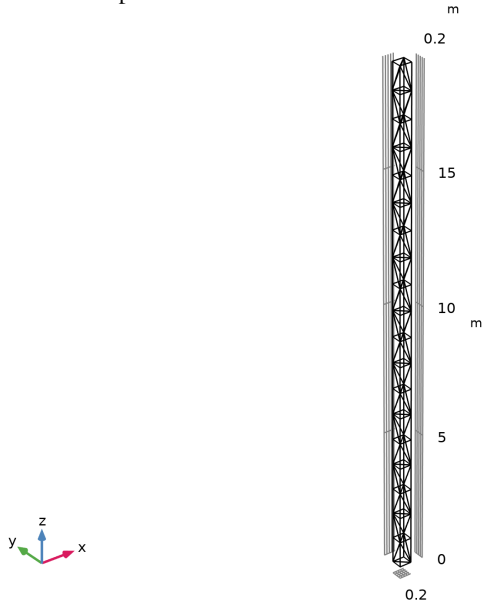

Figure 1: Geometry of the truss tower.

The tower is fixed at the ground level and a vertical load is applied at the top.

One fourth of the unit load is applied at each point of the tower top so that the critical load factor returned by the linear buckling analysis corresponds to the load that would cause the collapse of the structure.

A second study is performed to put in evidence the singularity at critical buckling load. To do so, the geometry is slightly deformed according to the first mode shape to initiate the buckling deformation. The load is then increased above the calculated critical buckling load in a stationary study using an auxiliary sweep.

Results and Discussion

For a simple column the critical buckling load is given by the Euler buckling formula

$$F_c = \frac{\pi^2 EI}{(KL)^2}$$

where E is the Young's modulus, I is the area moment of inertia, L is the unsupported length of the column and K is the column effective length factor.

For a column with one end fixed and the other end free to move laterally, $K = 2$.

For a tower like the one in this example with 4 main bars in the axial direction, the area of moment of inertia of the section can be computed as:

$$I = 4S\left(\frac{h}{2}\right)^2$$

where h is the distance between the vertical bars, and S the cross section area of the bars.

As the section is rectangular with different depth and width values, the tower has one weak direction. Here the depth is 40 cm and the width is 45 cm. This means that the first critical buckling load is expected to be about 86 kN in the depth direction (y direction). In the width direction, which is expected to be stiffer, the critical buckling load is estimated to be about 110 kN.

The results obtained with the linear buckling analysis agree well with these values. Note that the approximation given for the Euler buckling critical load is suitable for a tower structure when the height is significantly larger than the width or the depth.

Figure 2 shows the value of the first critical buckling load and the deformation shape.

Critical load factor=84820.1

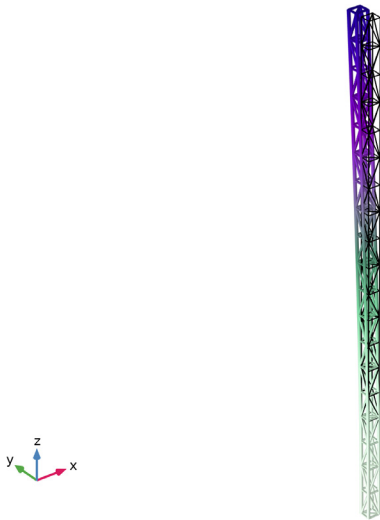

Figure 2: Deformation shape at the first critical buckling load.

Figure 3 shows the value of the second critical buckling load and the deformation shape.

Critical load factor=1.072E5 1

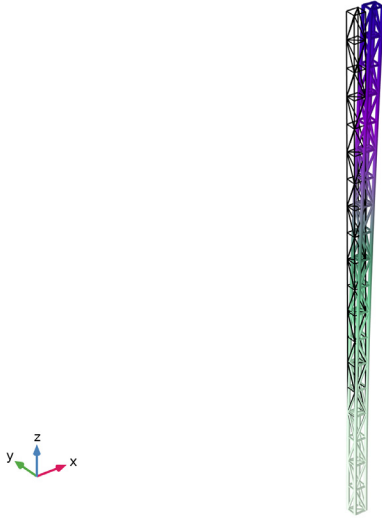

Figure 3: Deformation shape at the second critical buckling load.

In addition to the buckling of the whole structure, the safety against buckling of individual truss members must be studied. The critical compressive load for an individual bar can be calculated from material properties and the geometry of the bar:

$$F_{c, \text{bar}} = \frac{\pi^2 EI_{\min}}{(K_{\text{bar}} L_{\text{bar}})^2}$$

Here, I_{\min} is the moment of inertia in the weakest direction, based on the cross section data, and L_{bar} is the length of the bar. In this case the effective length factor K_{bar} is kept to its default value of 1, which corresponds to a pinned-pinned configuration. From this critical force and the compressive axial force N , the failure index f_i and the local buckling safety factor s_f can be calculated:

$$f_i = \frac{-N}{F_{c, \text{bar}}}$$

$$s_f = \frac{1}{f_i}$$

Based on the stationary step with unit loading it appears that the maximum buckling failure index is reached for some diagonal bars near the top of the tower (Figure 4), which undergo less compressive force than vertical bars, but are longer and thinner. The calculated minimal value of safety factor leads to a critical load of about 150 kN, which is significantly higher than the critical load of the two first modes for global buckling. Hence the global buckling will occur before the collapse of the individual truss members.

Line: Local buckling failure index (1) Max/Min Line: Local buckling safety factor (1)

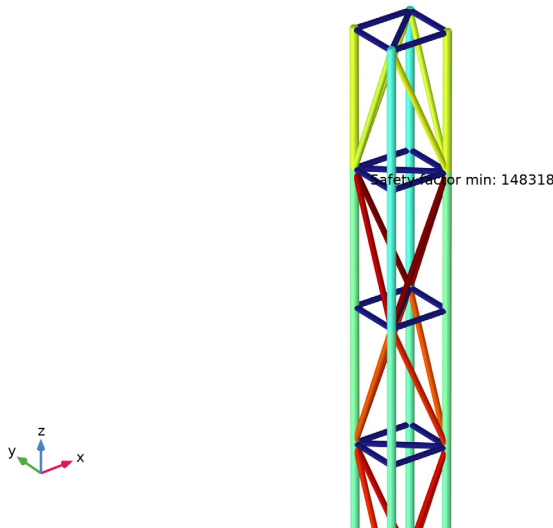

Figure 4: Maximum local buckling index, with value of minimal safety factor.

The plot of the force in post buckling analysis (Figure 5) shows that the higher forces are located at the base of the tower, while the points at the top of the tower have the maximum horizontal displacement. The displacement plot shows a sudden increase around the critical load, see Figure 6. The stress plot (Figure 7) also shows a sudden increase of the stress at critical load. The stress value becomes very high, probably higher than the physical limits of the material, which may cause a total collapse of the structure.

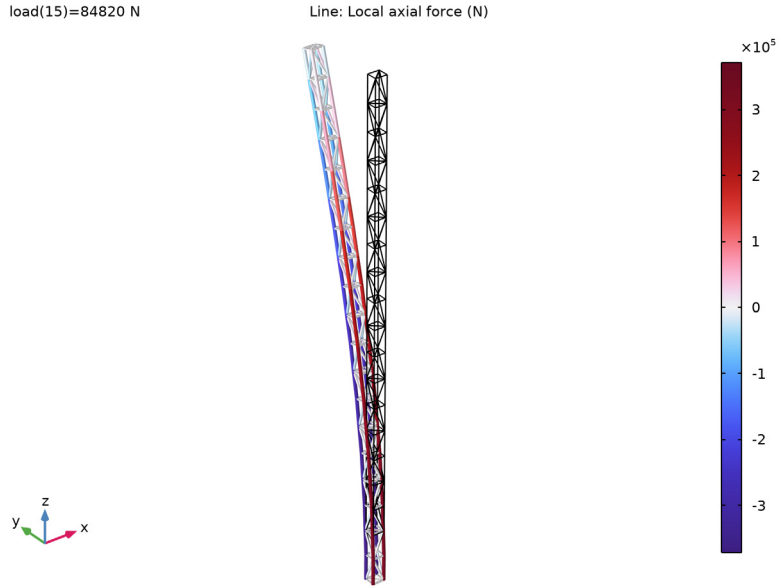

Figure 5: Force in truss at critical load.

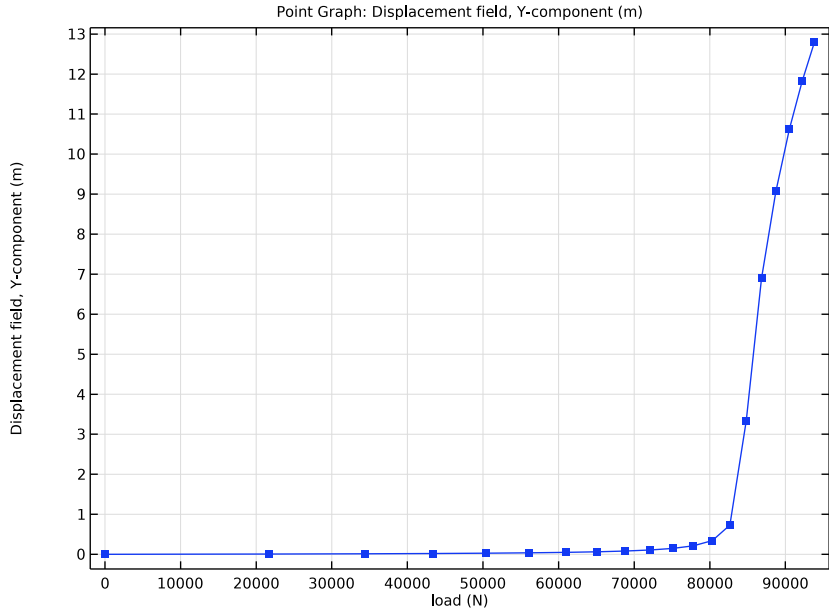

Figure 6: Displacement of the top of the tower in post buckling study.

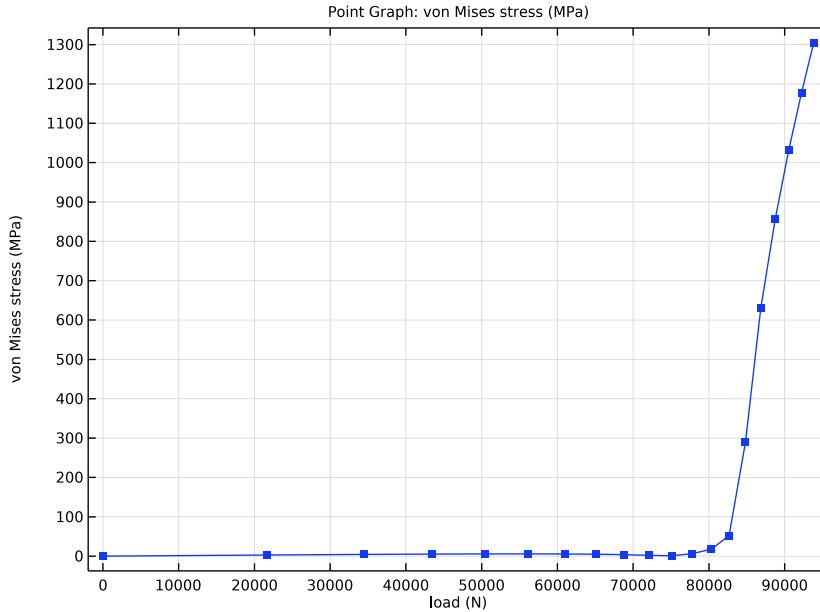

Figure 7: Stress in the truss at critical load.

Notes About the COMSOL Implementation

The settings of the post buckling analysis are made easier by the **Buckling Imperfection** node.

It contains a **Deformed Geometry** section that enables to choose the buckling solution and modes that will defined the prescribed displacements. The **Create** button generates one **Prescribed Deformation** node for each structural mechanics physics interface involved, and sets the prescribed deformations with the variables defined by the node. The prescribed deformations are those computed in the linear buckling study, multiplied by the scale factor. Low values of scale factor make the buckling effect sharper, but lead to more difficult convergence.

The **Nonlinear Buckling Study** section enables to select an existing study or choose to create a new one, and choose a parameter used to increase the loads in an auxiliary sweep. The **Create** button then creates a new stationary study if required, then checks **Include geometric nonlinearities** on, and applies an auxiliary sweep with the selected parameter. The

parameters values are filled based on the calculated critical buckling factor, with a logarithmic increase to capture accurately the behavior near the singularity.

Application Library path: Structural_Mechanics_Module/
Buckling_and_Wrinkling/truss_tower_buckling



Modeling Instructions

From the **File** menu, choose **New**.

NEW

In the **New** window, click  **Model Wizard**.

MODEL WIZARD

- 1 In the **Model Wizard** window, click  **3D**.
- 2 In the **Select Physics** tree, select **Structural Mechanics > Truss (truss)**.
- 3 Click **Add**.
- 4 Click  **Study**.
- 5 In the **Select Study** tree, select **Preset Studies for Selected Physics Interfaces > Linear Buckling**.
- 6 Click  **Done**.

GLOBAL DEFINITIONS

Geometric Parameters

- 1 In the **Model Builder** window, under **Global Definitions** click **Parameters I**.
- 2 In the **Settings** window for **Parameters**, type Geometric Parameters in the **Label** text field.
- 3 Locate the **Parameters** section. Click  **Load from File**.
- 4 Browse to the model's Application Libraries folder and double-click the file `truss_tower_buckling_geometric_parameters.txt`.

Loads

- 1 In the **Home** toolbar, click  **Parameters** and choose **Add > Parameters**.
- 2 In the **Settings** window for **Parameters**, type Loads in the **Label** text field.

3 Locate the **Parameters** section. In the table, enter the following settings:

Name	Expression	Value	Description
I1	$4 \cdot A1 \cdot (\text{depth}/2)^2$	6.2832E-5 m ⁴	Area moment of inertia weak direction
Fc1	$\pi^2 \cdot 200 \text{e9} [\text{Pa}] \cdot I1 / (2 \cdot L)^2$	85890 N	First critical buckling load
I2	$4 \cdot A1 \cdot (\text{width}/2)^2$	7.9522E-5 m ⁴	Area moment of inertia stiffer direction
Fc2	$\pi^2 \cdot 200 \text{e9} [\text{Pa}] \cdot I2 / (2 \cdot L)^2$	1.087E5 N	Second critical buckling load
load	1 [N]	1 N	Applied load

GEOMETRY I

Block 1 (blk1)

- 1 In the **Geometry** toolbar, click  **Block**.
- 2 In the **Settings** window for **Block**, locate the **Size and Shape** section.
- 3 In the **Width** text field, type width.
- 4 In the **Depth** text field, type depth.
- 5 In the **Height** text field, type height.

Convert to Curve 1 (ccur1)

- 1 In the **Geometry** toolbar, click  **Conversions** and choose **Convert to Curve**.
- 2 Select the object **blk1** only.

Polygon 1 (poll)



- 1 In the **Geometry** toolbar, click  **More Primitives** and choose **Polygon**.
- 2 In the **Settings** window for **Polygon**, locate the **Object Type** section.
- 3 From the **Type** list, choose **Closed curve**.
- 4 Locate the **Coordinates** section. In the table, enter the following settings:

x (m)	y (m)	z (m)
0	depth	0
0	0	height
width	0	0
width	depth	height

Line Segment 1 (ls1)

- 1 In the **Geometry** toolbar, click  **More Primitives** and choose **Line Segment**.
- 2 In the **Settings** window for **Line Segment**, locate the **Starting Point** section.
- 3 From the **Specify** list, choose **Coordinates**.
- 4 Locate the **Endpoint** section. From the **Specify** list, choose **Coordinates**.
- 5 Locate the **Starting Point** section. In the **y** text field, type depth.
- 6 Locate the **Endpoint** section. In the **x** text field, type width.

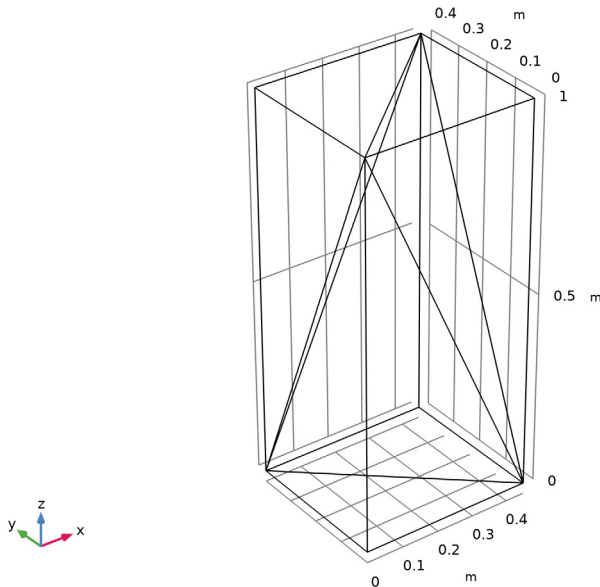

Line Segment 2 (ls2)

- 1 In the **Geometry** toolbar, click  **More Primitives** and choose **Line Segment**.
- 2 In the **Settings** window for **Line Segment**, locate the **Starting Point** section.
- 3 From the **Specify** list, choose **Coordinates**.
- 4 Locate the **Endpoint** section. From the **Specify** list, choose **Coordinates**.
- 5 Locate the **Starting Point** section. In the **z** text field, type height.
- 6 Locate the **Endpoint** section. In the **x** text field, type width, **y** to depth, and **z** to height.
- 7 In the **Geometry** toolbar, click  **Build All**.



Mirror 1 (mir1)

- 1 In the **Geometry** toolbar, click  **Transforms** and choose **Mirror**.

- 2 Click the  **Select All** button in the **Graphics** toolbar.
- 3 In the **Settings** window for **Mirror**, locate the **Input** section.
- 4 Select the **Keep input objects** checkbox.
- 5 Locate the **Point on Plane of Reflection** section. In the **z** text field, type height.
- 6 In the **Geometry** toolbar, click  **Build All**.

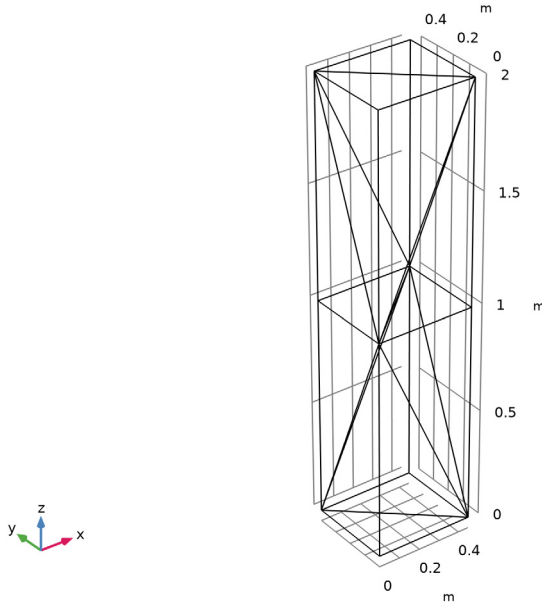



Array 1 (arr1)

- 1 In the **Geometry** toolbar, click  **Transforms** and choose **Array**.
- 2 Select the objects **ccur1**, **ls1**, **ls2**, and **poll** only.
- 3 In the **Settings** window for **Array**, locate the **Size** section.
- 4 In the **z size** text field, type n.
- 5 Locate the **Displacement** section. In the **z** text field, type $2 * \text{height}$.

Array 2 (arr2)

- 1 In the **Geometry** toolbar, click  **Transforms** and choose **Array**.
- 2 Select the objects **mir1(1)**, **mir1(2)**, and **mir1(4)** only.
- 3 In the **Settings** window for **Array**, locate the **Size** section.
- 4 In the **z size** text field, type $n - 1$.

- 5 Locate the **Displacement** section. In the **z** text field, type $2*\text{height}$.
- 6 In the **Geometry** toolbar, click  **Build All**.
- 7 Click the  **Go to Default View** button in the **Graphics** toolbar.

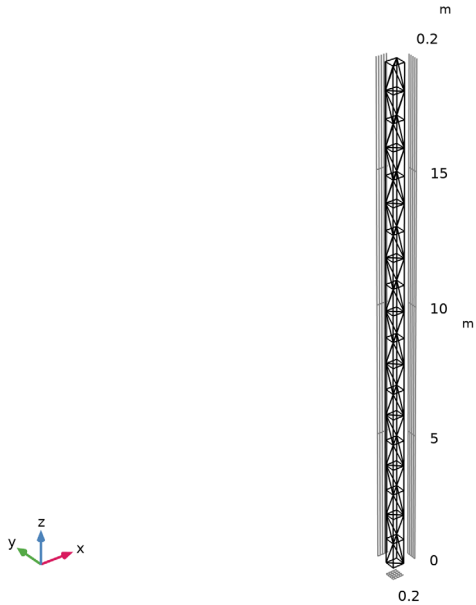

Create selections for vertical and transversal edges to make further modeling easier.

DEFINITIONS

Vertical Edges

- 1 In the **Definitions** toolbar, click  **Explicit**.
- 2 In the **Settings** window for **Explicit**, type **Vertical Edges** in the **Label** text field.
- 3 Locate the **Input Entities** section. From the **Geometric entity level** list, choose **Edge**.
- 4 Select Edges 1, 108, 176, and 234 only.

- 5 Select the **Group by continuous tangent** checkbox.

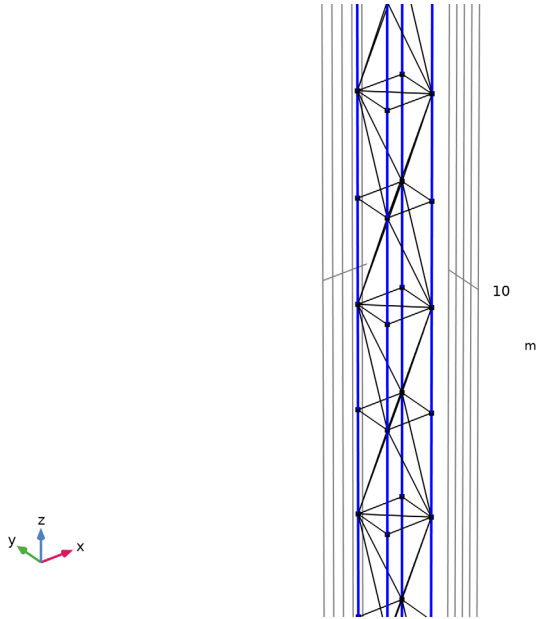



Transversal Edges

- 1 In the **Definitions** toolbar, click  **Complement**.
- 2 In the **Settings** window for **Complement**, type Transversal Edges in the **Label** text field.
- 3 Locate the **Geometric Entity Level** section. From the **Level** list, choose **Edge**.
- 4 Locate the **Input Entities** section. Under **Selections to invert**, click **+ Add**.
- 5 In the **Add** dialog, select **Vertical Edges** in the **Selections to invert** list.

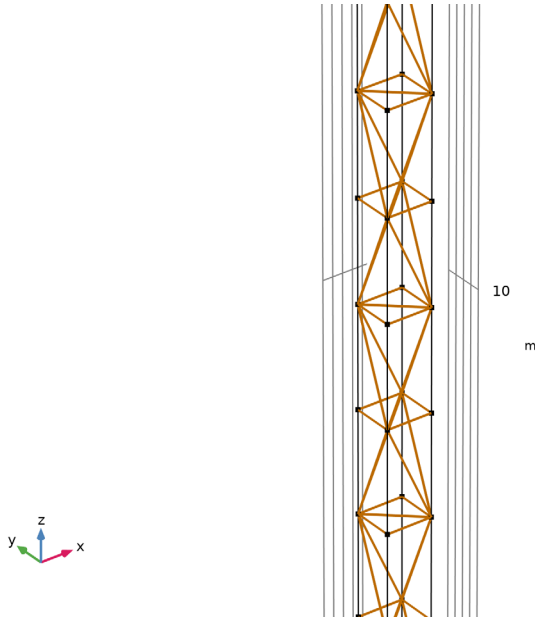
6 Click **OK**.



ADD MATERIAL

- 1 In the **Materials** toolbar, click  **Add Material** to open the **Add Material** window.
- 2 Go to the **Add Material** window.
- 3 In the tree, select **Built-in > Structural steel**.
- 4 Click the **Add to Component** button in the window toolbar.
- 5 In the **Materials** toolbar, click  **Add Material** to close the **Add Material** window.

TRUSS (TRUSS)

Cross-Section Data 1



- 1 In the **Settings** window for **Cross-Section Data**, locate the **Cross-Section Definition** section.
- 2 From the **Section type** list, choose **Pipe**.
- 3 In the d_o text field, type $d01$.
- 4 In the d_i text field, type $d11$.

Cross-Section Data 2



- 1 In the **Physics** toolbar, click  **Edges** and choose **Cross-Section Data**.
- 2 In the **Settings** window for **Cross-Section Data**, locate the **Edge Selection** section.

- 3 From the **Selection** list, choose **Transversal Edges**.
- 4 Locate the **Cross-Section Definition** section. From the **Section type** list, choose **Pipe**.
- 5 In the d_o text field, type do2.
- 6 In the d_i text field, type di2.

Pinned I

- 1 In the **Physics** toolbar, click  **Points** and choose **Pinned**.
- 2 In the **Settings** window for **Pinned**, locate the **Point Selection** section.
- 3 Click  **Paste Selection**.
- 4 In the **Paste Selection** dialog, type 1 21 41 61 in the **Selection** text field.
- 5 Click **OK**.

Point Load I

- 1 In the **Physics** toolbar, click  **Points** and choose **Point Load**.
- 2 In the **Settings** window for **Point Load**, locate the **Point Selection** section.
- 3 Click  **Paste Selection**.
- 4 In the **Paste Selection** dialog, type 20 40 60 80 in the **Selection** text field.
- 5 Click **OK**.
- 6 In the **Settings** window for **Point Load**, locate the **Force** section.
- 7 From the **Load type** list, choose **Total force**.
- 8 Specify the \mathbf{F}_{tot} vector as

0	x
0	y
-load	z



STUDY I

Step 2: Linear Buckling

- 1 In the **Model Builder** window, under **Study I** click **Step 2: Linear Buckling**.
- 2 In the **Settings** window for **Linear Buckling**, locate the **Study Settings** section.
- 3 In the **Desired number of buckling modes** text field, type 2.
- 4 In the **Study** toolbar, click  **Compute**.

RESULTS

Line 1

- 1 In the **Model Builder** window, expand the **Mode Shape (truss)** node, then click **Line 1**.
- 2 In the **Settings** window for **Line**, click to expand the **Title** section.
- 3 From the **Title type** list, choose **None**.
- 4 Locate the **Coloring and Style** section. In the **Radius scale factor** text field, type 4.
- 5 Click the  **Show Grid** button in the **Graphics** toolbar.
- 6 In the **Mode Shape (truss)** toolbar, click  **Plot**.

Create a new plot to check that local buckling of truss members occurs at higher load than the global buckling.

Local Buckling

- 1 In the **Results** toolbar, click  **3D Plot Group**.
- 2 In the **Settings** window for **3D Plot Group**, type Local Buckling in the **Label** text field.
- 3 Locate the **Data** section. From the **Dataset** list, choose **Study 1/Solution Store 1 (sol2)**.

Line 1

- 1 Right-click **Local Buckling** and choose **Line**.
- 2 In the **Settings** window for **Line**, click **Replace Expression** in the upper-right corner of the **Expression** section. From the menu, choose **Component 1 (comp1) > Truss > Safety > Local buckling > truss.lbf_i - Local buckling failure index - 1**.
- 3 Locate the **Coloring and Style** section. Clear the **Color legend** checkbox.
- 4 Click to expand the **Quality** section. From the **Smoothing** list, choose **None**.
- 5 Locate the **Coloring and Style** section. From the **Line type** list, choose **Tube**.
- 6 In the **Tube radius expression** text field, type `truss.re`.
- 7 Select the **Radius scale factor** checkbox. In the associated text field, type 2.

Local Buckling

In the **Model Builder** window, click **Local Buckling**.

Max/Min Line 1

- 1 In the **Local Buckling** toolbar, click  **More Plots** and choose **Max/Min Line**.
- 2 In the **Settings** window for **Max/Min Line**, click **Replace Expression** in the upper-right corner of the **Expression** section. From the menu, choose **Component 1 (comp1) > Truss > Safety > Local buckling > truss.lbs_f - Local buckling safety factor - 1**.
- 3 Locate the **Display** section. From the **Display** list, choose **Min**.

- 4 Locate the **Text Format** section. In the **Prefix** text field, type **Safety factor** .
- 5 In the **Local Buckling** toolbar, click  **Plot**.

Now prescribe a deformation to the geometry from the calculated buckling mode to perform a postbuckling study.

DEFINITIONS

Buckling Imperfection 1 (bck1)

- 1 In the **Definitions** toolbar, click  **Physics Utilities** and choose **Buckling Imperfection**.
- 2 In the **Settings** window for **Buckling Imperfection**, locate the **Deformed Geometry** section.
- 3 Find the **Mode selection** subsection. In the table, enter the following settings:

Mode	Scale factor
1	1e3

- 4 Click **Configure** in the upper-right corner of the **Deformed Geometry** section.
This button creates a **Prescribed Deformation** node with the requested deformation settings. The newly created **Prescribed Deformation** is automatically disabled in the existing study steps to enable further computation without changes in the results.
- 5 Locate the **Nonlinear Buckling Study** section. From the **Load parameter** list, choose **load**.
- 6 Click **Configure** in the upper-right corner of the **Nonlinear Buckling Study** section.
This button creates a new study with stationary step, activates geometric nonlinearities and applies an auxiliary sweep for the postbuckling study.

STUDY 2

Solution 3 (sol3)

- 1 In the **Model Builder** window, expand the **Component 1 (comp1) > Deformed Geometry** node.
- 2 Right-click **Study 2** and choose **Show Default Solver**.
- 3 In the **Model Builder** window, expand the **Solution 3 (sol3)** node.
- 4 In the **Model Builder** window, expand the **Study 2 > Solver Configurations > Solution 3 (sol3) > Stationary Solver 1** node, then click **Fully Coupled 1**.
- 5 In the **Settings** window for **Fully Coupled**, click to expand the **Method and Termination** section.
- 6 From the **Nonlinear method** list, choose **Constant (Newton)**.
- 7 In the **Study** toolbar, click  **Compute**.

RESULTS



Stress (truss)

- 1 In the **Settings** window for **3D Plot Group**, locate the **Data** section.
- 2 From the **Parameter value (load (N))** list, choose **84820**.

Line 1

- 1 In the **Model Builder** window, expand the **Stress (truss)** node, then click **Line 1**.
- 2 In the **Settings** window for **Line**, locate the **Expression** section.
- 3 From the **Unit** list, choose **MPa**.
- 4 Locate the **Coloring and Style** section. In the **Radius scale factor** text field, type 4.
- 5 In the **Stress (truss)** toolbar, click  **Plot**.

RESULT TEMPLATES

- 1 In the **Results** toolbar, click  **Result Templates** to open the **Result Templates** window.
- 2 Go to the **Result Templates** window.
- 3 In the tree, select **Study 2/Solution 3 (sol3) > Truss > Force (truss)**.
- 4 Click the **Add Result Template** button in the window toolbar.
- 5 In the **Results** toolbar, click  **Result Templates** to close the **Result Templates** window.

RESULTS

Force (truss)

- 1 In the **Settings** window for **3D Plot Group**, locate the **Data** section.
- 2 From the **Parameter value (load (N))** list, choose **84820**.

Line 1

- 1 In the **Model Builder** window, expand the **Force (truss)** node, then click **Line 1**.
- 2 In the **Settings** window for **Line**, locate the **Coloring and Style** section.
- 3 In the **Radius scale factor** text field, type 4.
- 4 In the **Force (truss)** toolbar, click  **Plot**.

Create a new plot to show the displacement with respect to applied load.

Post Buckling Displacement

- 1 In the **Results** toolbar, click  **ID Plot Group**.
- 2 In the **Settings** window for **ID Plot Group**, locate the **Data** section.
- 3 From the **Dataset** list, choose **Study 2/Solution 3 (sol3)**.

4 In the **Label** text field, type Post Buckling Displacement.



Point Graph 1

- 1 Right-click **Post Buckling Displacement** and choose **Point Graph**.
- 2 Select Point 20 only.
- 3 In the **Settings** window for **Point Graph**, locate the **y-Axis Data** section.
- 4 In the **Expression** text field, type v .
- 5 Click to expand the **Coloring and Style** section. Find the **Line markers** subsection. From the **Marker** list, choose **Point**.
- 6 In the **Post Buckling Displacement** toolbar, click  **Plot**.

Post Buckling Stress

- 1 In the **Model Builder** window, right-click **Post Buckling Displacement** and choose **Duplicate**.
- 2 In the **Settings** window for **ID Plot Group**, type Post Buckling Stress in the **Label** text field.

Point Graph 1

- 1 In the **Model Builder** window, expand the **Post Buckling Stress** node, then click **Point Graph 1**.
- 2 In the **Settings** window for **Point Graph**, locate the **Selection** section.
- 3 Click  **Clear Selection**.
- 4 Select Point 1 only.
- 5 Click **Replace Expression** in the upper-right corner of the **y-Axis Data** section. From the menu, choose **Component 1 (comp1) > Truss > Stress > truss.misesGp - von Mises stress - N/m²**.
- 6 Locate the **y-Axis Data** section. From the **Unit** list, choose **MPa**.
- 7 In the **Post Buckling Stress** toolbar, click  **Plot**.

