



# Axisymmetric Twist and Bending

## Introduction

---

When using a 2D axisymmetric Solid Mechanics interface, the primary dependent variables are, by default, the displacements in the radial and axial directions,  $u$  and  $w$ . It is, however, possible to also include the displacement component in the circumferential direction,  $v$ , which opens up the possibility to model both twisting and bending deformations. The extension of a 2D model to solve for a true 3D displacement field is sometimes referred to as a 2.5D formulation.

The primary objective of this model is to show how to model twist and bending in 2D axisymmetry. A hollow axisymmetric shaft is subjected to different load cases, and the stress concentration factors are derived for each case. The analyses are performed both in 2D axisymmetry and 3D to demonstrate their equivalence. However, if the geometry allows it, modeling in 2D axisymmetry is generally preferable being computationally significantly cheaper as well as more convenient to set up.

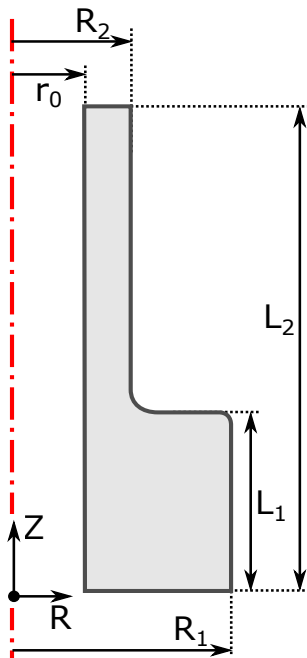

Figure 1: Shaft geometry and relevant geometric properties.

## Model Definition

The geometry of the hollow shaft is shown in [Figure 1](#). The transition between the thicker and thinner sections is slightly smoothed by a fillet. The shaft is made of steel (see [Table 1](#)) and behaves linear elastically.

TABLE 1: MATERIAL PROPERTIES.

PROPERTY	CABLE
Young's modulus	200 GPa
Poisson's ratio	0.3
Density	7850 kg/m <sup>3</sup>

The wider end is fixed, while a load is applied at the narrow end. Three different load cases are examined:

- 1 Axial extension
- 2 Torsion
- 3 Bending

In the transition region between the small and large shaft diameters, local stress concentrations are expected due to the disturbance in the stress field. For the three load cases, stress concentration factors are evaluated numerically in this model. In general, the geometrical stress concentration factor is defined as the ratio between the actual maximum stress,  $\sigma_{\max}$ , and the nominal stress,  $\sigma_{\text{nom}}$ , in the region where the stress field is disturbed:

$$K = \frac{\sigma_{\max}}{\sigma_{\text{nom}}}$$

Here, the nominal stress,  $\sigma_{\text{nom}}$ , is the stress computed from elementary theories. The stress concentration factors are defined as follows for the three load cases:

$$\text{Axial extension: } K_a = \frac{\max(\sigma_z)}{F_z/A} \text{ where } A = \pi(R_2^2 - r_0^2)$$

$$\text{Torsion: } K_t = \frac{\max(\sigma_{\varphi z})}{M_t R_2 / J} \text{ where } J = \frac{\pi(R_2^4 - r_0^4)}{2}$$

$$\text{Bending: } K_b = \frac{\max(\sigma_z)}{M_b R_2 / I} \text{ where } I = \frac{\pi(R_2^4 - r_0^4)}{4}$$

Here,  $F_z$ ,  $M_t$ , and  $M_b$  are the applied force in the  $z$  direction, the torsional moment, and the bending moment, respectively. Furthermore,  $A$ ,  $J$ , and  $I$  are the cross-section area, the torsional constant, and the area moment of inertia for the thinner section of the hollow shaft.

In order to solve for torsion and bending in 2D axisymmetry, the standard formulation has to be augmented by including the displacement in the circumferential direction,  $v$ , as a new dependent variable. By default, this circumferential displacement is assumed to be zero, and the extended 2D axisymmetric formulation must be turned on explicitly in COMSOL Multiphysics. Adding a new dependent variable increases the size of the system matrices slightly.

When the displacement field component in the  $\phi$  direction is added, the displacement gradient,  $\nabla \mathbf{u}$ , is automatically augmented to include the spatial variation of the circumferential displacement. The displacement gradient is a fundamental quantity used to define important variables such as strains and subsequently stresses. There can be alternative formulations of the displacement gradient depending on the chosen study type. In general, the gradient of the displacement field in a cylindrical coordinate system is defined as

$$\nabla \mathbf{u} = \begin{bmatrix} \frac{\partial u}{\partial R} & \frac{1}{R} \frac{\partial u}{\partial \phi} - \frac{v}{R} & \frac{\partial u}{\partial Z} \\ \frac{\partial v}{\partial R} & \frac{1}{R} \frac{\partial v}{\partial \phi} + \frac{u}{R} & \frac{\partial v}{\partial Z} \\ \frac{\partial w}{\partial R} & \frac{1}{R} \frac{\partial w}{\partial \phi} & \frac{\partial w}{\partial Z} \end{bmatrix}$$

Assuming that the displacement is constant in the circumferential direction, the derivatives with respect to  $\phi$  become zero, and  $\nabla \mathbf{u}$  simplifies to

$$\nabla \mathbf{u} = \begin{bmatrix} \frac{\partial u}{\partial R} & \frac{v}{R} & \frac{\partial u}{\partial Z} \\ \frac{\partial v}{\partial R} & \frac{u}{R} & \frac{\partial v}{\partial Z} \\ \frac{\partial w}{\partial R} & 0 & \frac{\partial w}{\partial Z} \end{bmatrix}$$

This formulation, which allows a constant displacement around the circumference, is available for all study types.

For frequency-domain and eigenfrequency studies, the displacement field is allowed to have a periodic variation in the  $\phi$  direction. This approach is sometimes referred to as a circumferential mode extension. The following complex-valued ansatz for the displacement field is assumed:

$$\hat{\mathbf{u}} = \mathbf{u}(R, Z)e^{-im\phi}$$

Here,  $m$  is the mode number. This ansatz allows periodic displacements in the circumferential direction, and it has two noteworthy special cases. The case of  $m = 0$  corresponds to a constant circumferential displacement, and  $m = 1$  allows a bending-type displacement. With the new ansatz, the displacement gradient becomes

$$\nabla \hat{\mathbf{u}} = \begin{bmatrix} \frac{\partial u}{\partial R} & -\frac{v}{R} & \frac{\partial u}{\partial Z} \\ \frac{\partial v}{\partial R} & \frac{u}{R} & \frac{\partial v}{\partial Z} \\ \frac{\partial w}{\partial R} & 0 & \frac{\partial w}{\partial Z} \end{bmatrix} - i\frac{m}{R} \begin{bmatrix} 0 & u & 0 \\ 0 & v & 0 \\ 0 & w & 0 \end{bmatrix}$$

This formulation is only available for frequency-domain and eigenfrequency studies, and it is only valid for small strains.

The assumed complex-valued displacement field has implications for how an excitation load should be applied when working with a cylindrical coordinate system since the force vector is to be entered according to the base vectors of the cylindrical system. In the corresponding 3D case, the bending load is applied as a total force acting in the positive  $X$  direction of the global Cartesian coordinate system. From a parallelogram of forces it can be shown that the force  $F_X$  can be written in terms of force components expressed in the cylindrical system.

$$F_X = F_R \cos \phi + F_\phi \sin \phi$$

The force entered in the load feature acts directly on the displacement field, hence the force vector is implicitly multiplied by  $e^{-im\phi}$ . Therefore, the load vector should be defined only as

$$\begin{pmatrix} F_R \\ F_\phi \\ F_Z \end{pmatrix} \rightarrow \begin{pmatrix} F_X \\ iF_X \\ 0 \end{pmatrix}$$

which corresponds to a real-valued load  $F_X$  acting in the  $X$  direction for  $m = 1$ .

## Results and Discussion

The von Mises stress distribution is shown in Figure 2 – Figure 4 for the three load cases, that is, axial extension, torsion, and bending. The 2D axisymmetric solution closely matches the 3D solution for all cases.

To find the highest stress value in the region of interest, the stress intensification factors are evaluated using a maximum operator (see the evaluation group *Stress Concentration Factors* under the **Results** node of the **Model Builder**). Again, the computationally leaner 2D axisymmetric solution shows good agreement with the full 3D result. Axial extension produces the highest stress concentration factor, followed by bending and torsion.

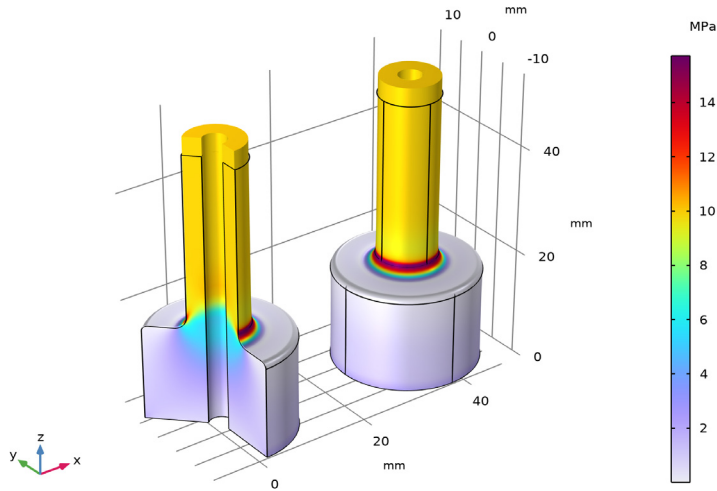

Figure 2: von Mises stress for axial load as computed in 2D axisymmetry (left) and 3D.

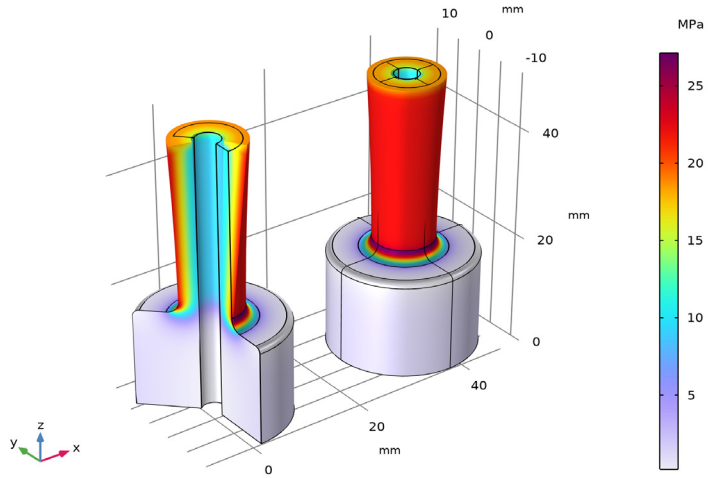

Figure 3: von Mises stress for torsional load as computed in 2D axisymmetry (left) and 3D.

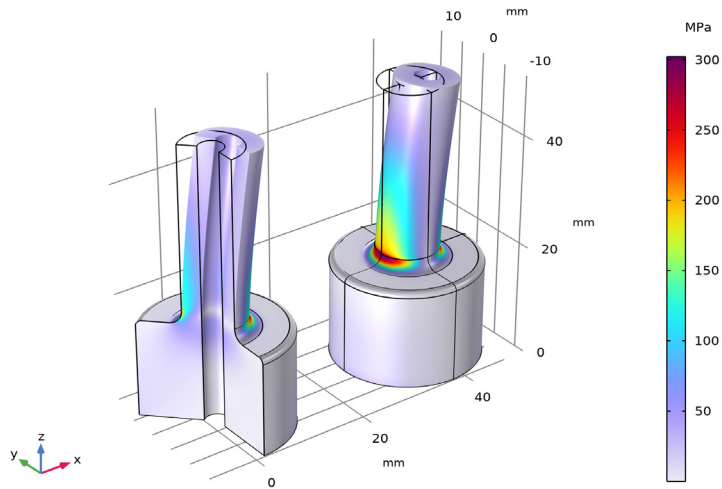

Figure 4: von Mises stress for bending load as computed in 2D axisymmetry (left) and 3D.

It is worth highlighting that the number of degrees of freedom (DOFs) is roughly 25 times higher for the 3D model, which directly affects assembly and solver time. When

investigating stress concentrations, it is often of interest to examine effects of geometrical changes such as varying fillet or diameter sizes in between different shaft sections. Such geometrical investigations can easily be performed in COMSOL Multiphysics using parametric sweeps. The geometry needs to be rebuilt and remeshed, and the model needs to be re-solved. This can be done more efficiently with only a 2D geometry.

### *Notes About the COMSOL Implementation*

---

The model is set up and solved for twice in order to show the equivalence between the 2D axisymmetric and full 3D formulations.

Bending deformations in 2D axisymmetry can only be computed in frequency-domain or in eigenfrequency studies. Therefore, a frequency-domain study is added with an excitation frequency of 0 Hz. This corresponds to a stationary analysis since the applied loads will have no time-harmonic part.

Note also that all three load cases could have been solved for with a single frequency-domain study. In this case, the azimuthal mode number would have had to be defined as

$$m = \text{if}(\text{group.lg3}, 1, 0)$$

Here, `group.lg3` is the weight variable of load group 3 (bending). The variable is defined in the **Study Extensions** section when adding load cases. The above expression for  $m$  sets the azimuthal mode number to 0 for the first and second load cases (that is, axial extension and torsion) and to 1 for the third load case (that is, bending).

---

**Application Library path:** Structural\_Mechanics\_Module/  
Verification\_Examples/axisymmetric\_twist\_and\_bending

---

### *Modeling Instructions*

---



From the **File** menu, choose **New**.

#### **NEW**

In the **New** window, click  **Model Wizard**.

#### **MODEL WIZARD**

- 1 In the **Model Wizard** window, click  **2D Axisymmetric**.
- 2 In the **Select Physics** tree, select **Structural Mechanics > Solid Mechanics (solid)**.

- 3 Click **Add**.
- 4 Click  **Study**.
- 5 In the **Select Study** tree, select **General Studies > Stationary**.
- 6 Click  **Done**.

## GLOBAL DEFINITIONS

### Parameters I

- 1 In the **Model Builder** window, under **Global Definitions** click **Parameters I**.
- 2 In the **Settings** window for **Parameters**, locate the **Parameters** section.
- 3 In the table, enter the following settings:

Name	Expression	Value	Description
r0	2[mm]	0.002 m	Inner radius
R1	12[mm]	0.012 m	Outer radius, thick section
R2	5[mm]	0.005 m	Outer radius, thin section
L1	18[mm]	0.018 m	Length, thick section
L2	50[mm]	0.05 m	Length, thin section
I	$(\pi/4) * (R2^4 - r0^4)$	4.7831E-10 m <sup>4</sup>	Area moment of inertia
J	2*I	9.5661E-10 m <sup>4</sup>	Torsion constant
A_load	$\pi * (R2^2 - r0^2)$	6.5973E-5 m <sup>2</sup>	Area of applied load
F_load	10[MPa]*A_load	659.73 N	Total applied force
Mt	$(2*\pi/3) * (F\_load / A\_load) * (R2^3 - r0^3)$	2.4504 N·m	Equivalent twisting moment
Mb	F_load*(L2 - L1)	21.112 N·m	Bending moment at transition

Create a 2D shaft section as a global geometry part so that it can be referenced by the 2D axisymmetric and 3D components, respectively.

## SHAFT SECTION

- 1 In the **Model Builder** window, right-click **Global Definitions** and choose **Geometry Parts > 2D Part**.

- 2 In the **Settings** window for **Part**, type Shaft Section in the **Label** text field.
- 3 Locate the **Units** section. From the **Length unit** list, choose **mm**.

*Polygon 1 (pol1)*

- 1 In the **Geometry** toolbar, click  **Polygon**.
- 2 In the **Settings** window for **Polygon**, locate the **Coordinates** section.
- 3 In the table, enter the following settings:

x (mm)	y (mm)
r0	0
R1	0
R1	L1
R2	L1
R2	L2
r0	L2



*Fillet 1 (fil1)*

- 1 In the **Geometry** toolbar, click  **Fillet**.
- 2 On the object **pol1**, select Point 3 only.
- 3 In the **Settings** window for **Fillet**, locate the **Radius** section.
- 4 In the **Radius** text field, type 1.

*Fillet 2 (fil2)*

- 1 In the **Geometry** toolbar, click  **Fillet**.
- 2 On the object **fil1**, select Point 3 only.
- 3 In the **Settings** window for **Fillet**, locate the **Radius** section.
- 4 In the **Radius** text field, type 2.
- 5 In the **Geometry** toolbar, click  **Build All**.

**ADD MATERIAL**

- 1 In the **Home** toolbar, click  **Add Material** to open the **Add Material** window.
- 2 Go to the **Add Material** window.
- 3 In the tree, select **Built-in** > **Structural steel**.
- 4 Right-click and choose **Add to Global Materials**.
- 5 In the **Home** toolbar, click  **Add Material** to close the **Add Material** window.

## GLOBAL DEFINITIONS

### *Axial Extension*

- 1 Right-click **Global Definitions** and choose **Load and Constraint Groups > Load Group**.
- 2 In the **Settings** window for **Load Group**, type Axial Extension in the **Label** text field.

### *Torsion*

- 1 In the **Model Builder** window, right-click **Load and Constraint Groups** and choose **Load Group**.
- 2 In the **Settings** window for **Load Group**, type Torsion in the **Label** text field.

### *Bending*

- 1 Right-click **Load and Constraint Groups** and choose **Load Group**.
- 2 In the **Settings** window for **Load Group**, type Bending in the **Label** text field.

## GEOMETRY I

- 1 In the **Model Builder** window, under **Component 1 (comp1)** click **Geometry 1**.
- 2 In the **Settings** window for **Geometry**, locate the **Units** section.
- 3 From the **Length unit** list, choose **mm**.

### *Shaft Section 1 (pil)*

In the **Geometry** toolbar, click  **Part Instance** and choose **Shaft Section**.

## MATERIALS

### *Material Link 1 (matlnk1)*

In the **Model Builder** window, under **Component 1 (comp1)** right-click **Materials** and choose **More Materials > Material Link**.

Next, include the circumferential displacement as a new dependent variable to allow twisting deformations. In addition, enable the mode extension with mode number 1, which allows to compute bending deformations in frequency domain.

## SOLID MECHANICS (SOLID)

- 1 In the **Settings** window for **Solid Mechanics**, locate the **Axial Symmetry Approximation** section.
- 2 Select the **Include circumferential displacement** checkbox.
- 3 Find the **Time-harmonic** subsection. Select the **Circumferential mode extension** checkbox.
- 4 In the *m* text field, type 1.

*Fixed Constraint 1*

- 1 In the **Physics** toolbar, click  **Boundaries** and choose **Fixed Constraint**.
- 2 Select Boundary 2 only.

*Boundary Load: Axial Extension*

- 1 In the **Physics** toolbar, click  **Boundaries** and choose **Boundary Load**.
- 2 In the **Settings** window for **Boundary Load**, type Boundary Load: Axial Extension in the **Label** text field.
- 3 Select Boundary 3 only.
- 4 Locate the **Force** section. From the **Load type** list, choose **Total force**.
- 5 Specify the  $\mathbf{F}_{\text{tot}}$  vector as

0	r
0	phi
F_load	z

- 6 In the **Physics** toolbar, click  **Load Group** and choose **Axial Extension**.

*Boundary Load: Torsion*

- 1 In the **Physics** toolbar, click  **Boundaries** and choose **Boundary Load**.
- 2 In the **Settings** window for **Boundary Load**, type Boundary Load: Torsion in the **Label** text field.
- 3 Select Boundary 3 only.
- 4 Locate the **Force** section. From the **Load type** list, choose **Total force**.
- 5 Specify the  $\mathbf{F}_{\text{tot}}$  vector as

0	r
F_load	phi
0	z

- 6 In the **Physics** toolbar, click  **Load Group** and choose **Torsion**.

*Boundary Load: Bending*

- 1 In the **Physics** toolbar, click  **Boundaries** and choose **Boundary Load**.

The bending force will be active only in frequency domain, where a complex-valued displacement field is assumed. The real part of the force should act only in  $x$  direction when interpreted in a Cartesian coordinate system. The coordinate transformation from the cylindrical to Cartesian system requires the force to be complex-valued.

- 2 In the **Settings** window for **Boundary Load**, type Boundary Load: Bending in the **Label** text field.
- 3 Select Boundary 3 only.
- 4 Locate the **Force** section. From the **Load type** list, choose **Total force**.
- 5 Specify the  $\mathbf{F}_{\text{tot}}$  vector as

F_load	r
-i*F_load	phi
0	z

- 6 In the **Physics** toolbar, click  **Load Group** and choose **Bending**.

## MESH I

### *Free Triangular I*

In the **Mesh** toolbar, click  **Free Triangular**.

### *Distribution I*

- 1 Right-click **Free Triangular I** and choose **Distribution**.
- 2 Select Boundary 7 only.
- 3 In the **Settings** window for **Distribution**, locate the **Distribution** section.
- 4 In the **Number of elements** text field, type 20.

### *Size*

- 1 In the **Model Builder** window, under **Component 1 (comp1) > Mesh 1** click **Size**.
- 2 In the **Settings** window for **Size**, locate the **Element Size** section.
- 3 From the **Predefined** list, choose **Finer**.
- 4 Click  **Build All**.

## DEFINITIONS

### *Maximum I (maxop1)*

- 1 In the **Definitions** toolbar, click  **Nonlocal Couplings** and choose **Maximum**.
- 2 In the **Settings** window for **Maximum**, type max2Daxi in the **Operator name** text field.
- 3 Locate the **Source Selection** section. From the **Geometric entity level** list, choose **Boundary**.
- 4 Select Boundaries 4, 5, and 7 only.

## ADD COMPONENT

In the **Model Builder** window, right-click the root node and choose **Add Component > 3D**.

## GEOMETRY 2

- 1 In the **Settings** window for **Geometry**, locate the **Units** section.
- 2 From the **Length unit** list, choose **mm**.

*Work Plane 1 (wp1)*

- 1 In the **Geometry** toolbar, click  **Work Plane**.
- 2 In the **Settings** window for **Work Plane**, locate the **Plane Definition** section.
- 3 From the **Plane** list, choose **xz-plane**.

*Work Plane 1 (wp1) > Plane Geometry*

In the **Model Builder** window, click **Plane Geometry**.

*Work Plane 1 (wp1) > Shaft Section 1 (pi1)*

In the **Work Plane** toolbar, click  **Part Instance** and choose **Shaft Section**.

*Revolve 1 (rev1)*



- 1 In the **Model Builder** window, under **Component 2 (comp2) > Geometry 2** right-click **Work Plane 1 (wp1)** and choose **Revolve**.
- 2 In the **Settings** window for **Revolve**, click  **Build All Objects**.

## DEFINITIONS (COMP2)

*Cylindrical System (Material Frame)*

- 1 In the **Definitions** toolbar, click  **Coordinate Systems** and choose **Cylindrical System**.
- 2 In the **Settings** window for **Cylindrical System**, type Cylindrical System (Material Frame) in the **Label** text field.
- 3 Locate the **Coordinate Names** section. From the **Frame** list, choose **Material (X, Y, Z)**.

## ADD PHYSICS

- 1 In the **Home** toolbar, click  **Add Physics** to open the **Add Physics** window.
- 2 Go to the **Add Physics** window.
- 3 In the tree, select **Structural Mechanics > Solid Mechanics (solid)**.
- 4 Click the **Add to Component 2** button in the window toolbar.
- 5 In the **Home** toolbar, click  **Add Physics** to close the **Add Physics** window.

## MATERIALS

### Material Link 2 (matlnk2)

In the **Model Builder** window, under **Component 2 (comp2)** right-click **Materials** and choose **More Materials > Material Link**.

## SOLID MECHANICS 2 (SOLID2)

### Fixed Constraint 1

- 1 In the **Physics** toolbar, click  **Boundaries** and choose **Fixed Constraint**.
- 2 Select Boundaries 3, 4, 18, and 26 only.

### Boundary Load: Axial Extension

- 1 In the **Physics** toolbar, click  **Boundaries** and choose **Boundary Load**.
- 2 In the **Settings** window for **Boundary Load**, type Boundary Load: Axial Extension in the **Label** text field.
- 3 Select Boundaries 13, 14, 23, and 27 only.
- 4 Locate the **Force** section. From the **Load type** list, choose **Total force**.
- 5 Specify the  $\mathbf{F}_{\text{tot}}$  vector as

0	x
0	y
F_load	z

- 6 In the **Physics** toolbar, click  **Load Group** and choose **Axial Extension**.

### Boundary Load: Torsion

- 1 In the **Physics** toolbar, click  **Boundaries** and choose **Boundary Load**.
- 2 In the **Settings** window for **Boundary Load**, type Boundary Load: Torsion in the **Label** text field.
- 3 Select Boundaries 13, 14, 23, and 27 only.
- 4 Locate the **Coordinate System Selection** section. From the **Coordinate system** list, choose **Cylindrical System (Material Frame) (sys3)**.
- 5 Locate the **Force** section. From the **Load type** list, choose **Total force**.
- 6 Specify the  $\mathbf{F}_{\text{tot}}$  vector as

0	r
---	---

F_load	phi
0	a

7 In the **Physics** toolbar, click  **Load Group** and choose **Torsion**.

*Boundary Load: Bending*

- 1 In the **Physics** toolbar, click  **Boundaries** and choose **Boundary Load**.
- 2 In the **Settings** window for **Boundary Load**, type Boundary Load: Bending in the **Label** text field.
- 3 Select Boundaries 13, 14, 23, and 27 only.
- 4 Locate the **Force** section. From the **Load type** list, choose **Total force**.
- 5 Specify the  $\mathbf{F}_{\text{tot}}$  vector as

F_load	x
0	y
0	z

6 In the **Physics** toolbar, click  **Load Group** and choose **Bending**.

Add a **Local System Results** node to evaluate stress components in cylindrical coordinates.

*Local System Results 1*

- 1 In the **Physics** toolbar, click  **Domains** and choose **Local System Results**.
- 2 In the **Settings** window for **Local System Results**, locate the **Coordinate System Selection** section.
- 3 From the **Coordinate system** list, choose **Cylindrical System (Material Frame) (sys3)**.

**DEFINITIONS (COMP2)**

*Maximum 2 (maxop2)*

- 1 In the **Definitions** toolbar, click  **Nonlocal Couplings** and choose **Maximum**.
- 2 In the **Settings** window for **Maximum**, locate the **Source Selection** section.
- 3 From the **Geometric entity level** list, choose **Boundary**.
- 4 In the **Operator name** text field, type max3D.
- 5 Select Boundaries 7–12, 20–22, and 28–30 only.

## MESH 2

### Free Triangular 1

- 1 In the **Mesh** toolbar, click  **More Generators** and choose **Free Triangular**.
- 2 Select Boundary 33 only.

### Distribution 1

- 1 Right-click **Free Triangular 1** and choose **Distribution**.
- 2 Select Edge 61 only.
- 3 In the **Settings** window for **Distribution**, locate the **Distribution** section.
- 4 In the **Number of elements** text field, type 20.

### Swept 1

In the **Mesh** toolbar, click  **Swept**.

### Size

- 1 In the **Model Builder** window, click **Size**.
- 2 In the **Settings** window for **Size**, locate the **Element Size** section.
- 3 From the **Predefined** list, choose **Extra fine**.
- 4 Click  **Build All**.

## STUDY 1: AXIAL EXTENSION & TORSION

- 1 In the **Model Builder** window, click **Study 1**.
- 2 In the **Settings** window for **Study**, type Study 1: Axial Extension & Torsion in the **Label** text field.

### Step 1: Stationary

- 1 In the **Model Builder** window, under **Study 1: Axial Extension & Torsion** click **Step 1: Stationary**.
- 2 In the **Settings** window for **Stationary**, click to expand the **Study Extensions** section.
- 3 Select the **Define load cases** checkbox.
- 4 Click **+ Add**.
- 5 In the table, enter the following settings:

Load case	lg1	Weight	lg2	Weight	lg3	Weight
Axial Extension	√	1.0		1.0		1.0

- 6 Click **+ Add**.

7 In the table, enter the following settings:



Load case	Ig1	Weight	Ig2	Weight	Ig3	Weight
Torsion		1.0	√	1.0		1.0

8 In the **Study** toolbar, click  **Compute**.

## RESULTS

Set default units for result presentation.



*Preferred Units 1*

- 1 In the **Results** toolbar, click  **Configurations** and choose **Preferred Units**.
- 2 In the **Settings** window for **Preferred Units**, locate the **Units** section.
- 3 Click  **Add Physical Quantity**.
- 4 In the **Physical Quantity** dialog, type `stress` in the text field.
- 5 In the tree, select **Solid Mechanics > Stress tensor (N/m^2)**.
- 6 Click **OK**.
- 7 In the **Settings** window for **Preferred Units**, locate the **Units** section.
- 8 In the table, enter the following settings:

Quantity	Unit	Preferred unit
Stress tensor	N/m^2	MPa

9 Click  **Apply**.

## ADD STUDY

- 1 In the **Home** toolbar, click  **Add Study** to open the **Add Study** window.
- 2 Go to the **Add Study** window.
- 3 Find the **Studies** subsection. In the **Select Study** tree, select **General Studies > Frequency Domain**.
- 4 Click the **Add Study** button in the window toolbar.
- 5 In the **Home** toolbar, click  **Add Study** to close the **Add Study** window.

Bending in 2D axisymmetry requires a special ansatz for the displacement field which is only available for frequency-domain (and eigenfrequency) studies. In order to solve for a stationary response using a frequency-domain study, set the target frequency to 0.

## STUDY 2: BENDING

In the **Settings** window for **Study**, type Study 2: Bending in the **Label** text field.

### Step 1: Frequency Domain

- 1 In the **Model Builder** window, under **Study 2: Bending** click **Step 1: Frequency Domain**.
- 2 In the **Settings** window for **Frequency Domain**, locate the **Study Settings** section.
- 3 In the **Frequencies** text field, type 0.
- 4 Click to expand the **Study Extensions** section. Select the **Define load cases** checkbox.
- 5 Click **+ Add**.
- 6 In the table, enter the following settings:

Load case	Ig1	Weight	Ig2	Weight	Ig3	Weight
Bending		1.0		1.0	$\sqrt{\quad}$	1.0

- 7 In the **Study** toolbar, click **= Compute**.

## RESULTS

### Stress: Axial Extension & Torsion (2D axi & 3D)

- 1 In the **Model Builder** window, under **Results** click **Stress, 3D (solid)**.
- 2 In the **Settings** window for **3D Plot Group**, type Stress: Axial Extension & Torsion (2D axi & 3D) in the **Label** text field.
- 3 Click to expand the **Title** section. From the **Title type** list, choose **None**.
- 4 Locate the **Color Legend** section. Select the **Show units** checkbox.

### Surface 2

- 1 Right-click **Stress: Axial Extension & Torsion (2D axi & 3D)** and choose **Surface**.
- 2 In the **Settings** window for **Surface**, locate the **Data** section.
- 3 From the **Dataset** list, choose **Study 1: Axial Extension & Torsion/Solution 1 (2) (sol1)**.
- 4 From the **Solution parameters** list, choose **From parent**.
- 5 Locate the **Expression** section. In the **Expression** text field, type solid2.mises.
- 6 Click to expand the **Inherit Style** section. From the **Plot** list, choose **Surface 1**.

### Deformation 1

Right-click **Surface 2** and choose **Deformation**.

### Transformation 1

- 1 In the **Model Builder** window, right-click **Surface 2** and choose **Transformation**.

- 2 In the **Settings** window for **Transformation**, locate the **Transformation** section.
- 3 In the **X** text field, type 3\*R1.
- 4 Clear the **Apply to dataset edges** checkbox.

*Stress: Axial Extension & Torsion (2D axi & 3D)*

- 1 In the **Model Builder** window, under **Results** click **Stress: Axial Extension & Torsion (2D axi & 3D)**.
- 2 In the **Settings** window for **3D Plot Group**, click **← Plot First**.
- 3 Click **→ Plot Next**.

*Stress: Bending (2D axi & 3D)*

- 1 In the **Model Builder** window, expand the **Results > Stress, 3D (solid) I** node, then click **Stress, 3D (solid) I**.
- 2 In the **Settings** window for **3D Plot Group**, type **Stress: Bending (2D axi & 3D)** in the **Label** text field.
- 3 Locate the **Title** section. From the **Title type** list, choose **None**.
- 4 Locate the **Color Legend** section. Select the **Show units** checkbox.

*Surface 1*

- 1 In the **Model Builder** window, click **Surface 1**.
- 2 In the **Settings** window for **Surface**, locate the **Expression** section.
- 3 In the **Expression** text field, type **solid.mises**.

*Surface 2*

- 1 In the **Model Builder** window, right-click **Stress: Bending (2D axi & 3D)** and choose **Surface**.
- 2 In the **Settings** window for **Surface**, locate the **Data** section.
- 3 From the **Dataset** list, choose **Study 2: Bending/Solution 2 (4) (sol2)**.
- 4 Locate the **Expression** section. In the **Expression** text field, type **solid2.mises**.
- 5 Locate the **Inherit Style** section. From the **Plot** list, choose **Surface 1**.

*Deformation 1*

Right-click **Surface 2** and choose **Deformation**.

*Transformation 1*

- 1 In the **Model Builder** window, right-click **Surface 2** and choose **Transformation**.
- 2 In the **Settings** window for **Transformation**, locate the **Transformation** section.
- 3 In the **X** text field, type 3\*R1.

- 4 Clear the **Apply to dataset edges** checkbox.

#### Stress Concentration Factors

- 1 In the **Results** toolbar, click  **Evaluation Group**.
- 2 In the **Settings** window for **Evaluation Group**, type Stress Concentration Factors in the **Label** text field.
- 3 Locate the **Data** section. From the **Dataset** list, choose **None**.
- 4 Locate the **Transformation** section. Select the **Transpose** checkbox.
- 5 Click to expand the **Format** section. From the **Include parameters** list, choose **Off**.

#### Global Evaluation 1

- 1 Right-click **Stress Concentration Factors** and choose **Global Evaluation**.
- 2 In the **Settings** window for **Global Evaluation**, locate the **Data** section.
- 3 From the **Dataset** list, choose **Study 1: Axial Extension & Torsion/Solution 1 (I) (sol1)**.
- 4 From the **Parameter selection (Load case)** list, choose **First**.
- 5 Locate the **Expressions** section. In the table, enter the following settings:

Expression	Unit	Description
$\text{max2Daxi}(\text{solid.szz}) / (\text{F\_load} / \text{A\_load})$	1	Axial extension (2D axi)
$\text{comp2.max3D}(\text{comp2.solid2.lsr1.s133}) / (\text{F\_load} / \text{A\_load})$	1	Axial extension (3D)

#### Global Evaluation 2

- 1 In the **Model Builder** window, right-click **Stress Concentration Factors** and choose **Global Evaluation**.
- 2 In the **Settings** window for **Global Evaluation**, locate the **Data** section.
- 3 From the **Dataset** list, choose **Study 1: Axial Extension & Torsion/Solution 1 (I) (sol1)**.
- 4 From the **Parameter selection (Load case)** list, choose **Last**.
- 5 Locate the **Expressions** section. In the table, enter the following settings:

Expression	Unit	Description
$\text{max2Daxi}(\text{solid.sphiz}) / (\text{Mt} * \text{R2} / \text{J})$		Torsion (2D axi)
$\text{comp2.max3D}(\text{solid2.lsr1.s123}) / (\text{Mt} * \text{R2} / \text{J})$	1	Torsion (3D)

The local stress component `solid2.lsr1.s123` in 3D represents the shear stress  $s_{\varphi z}$ , as a cylindrical system was selected in the **Local System Results** node.

### Global Evaluation 3

- 1 Right-click **Stress Concentration Factors** and choose **Global Evaluation**.
- 2 In the **Settings** window for **Global Evaluation**, locate the **Data** section.
- 3 From the **Dataset** list, choose **Study 2: Bending/Solution 2 (3) (sol2)**.
- 4 From the **Parameter selection (freq)** list, choose **Last**.
- 5 From the **Parameter selection (Load case)** list, choose **Last**.
- 6 Locate the **Expressions** section. In the table, enter the following settings:

Expression	Unit	Description
$\max2Daxi(\text{abs}(\text{solid.szz}))/(\text{Mb}*\text{R}2/\text{I})$	1	Bending (2D axi)
$\text{comp2.max3D}(\text{solid2.lsr1.sl33})/(\text{Mb}*\text{R}2/\text{I})$	1	Bending (3D)

- 7 In the **Stress Concentration Factors** toolbar, click  **Evaluate**.