



Lightning Surge Analysis of an Offshore Wind Farm

Introduction

In offshore wind farms, wind turbine resilience against lightning strikes is crucial. Lightning surges can threaten the turbines' reliability and the wind farm's efficiency. This model simulates the effects of a lightning strike on one turbine and its resulting induced electric fields on adjacent turbines.

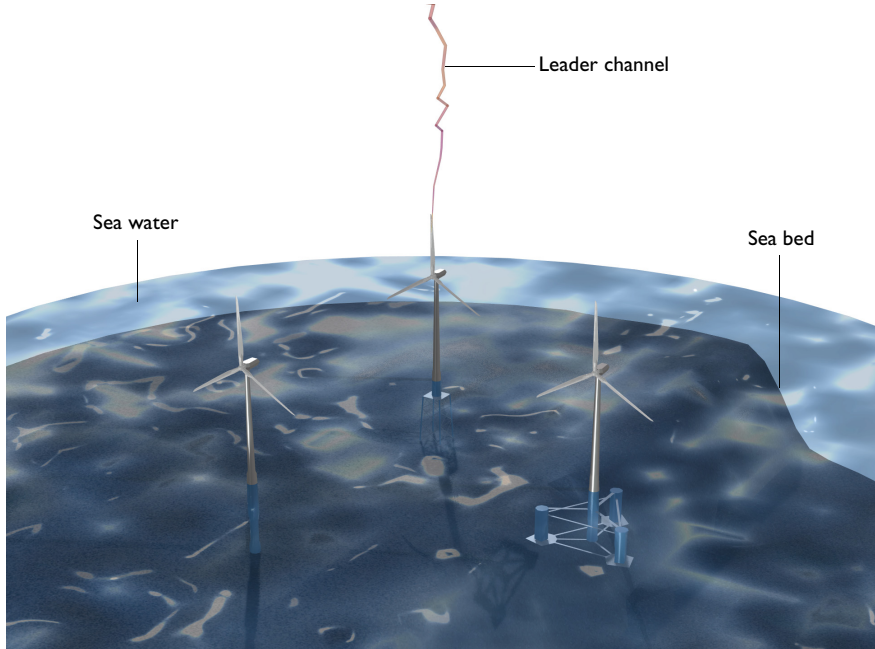

Figure 1: The view of an offshore wind farm. Lightning strikes one of the turbine blades.

This simulation aids in understanding the potential impacts of lightning on interconnected turbines within an offshore wind farm. Through analysis of these fields, engineers and researchers can gauge potential overvoltages and transient effects, thereby informing design for protection measures, wind turbine layout optimization, and continuous farm operation.

Model Definition

The model's geometry accurately reflects an offshore wind farm, detailing the strategic placement of turbines and their connectivity to the power grid. This spatial configuration plays a crucial role as it influences the propagation of the induced electric fields. Effects

from the saline water and the sea bed are essential components of the model given the offshore setting.

Assuming negligible losses from finite conductivity, the turbine's framework, which encompasses the tower, inner strips, and tower support structures, is characterized by perfect electric conductors. Meanwhile, the turbine blades, deemed RF-transparent, are excluded from the model for simplification.

Simulating the actual lightning strike, an edge current feature defines a 20 kA current source that targets a turbine, capturing the temporal nuances of a lightning surge. Furthermore, to emulate an expansive environment and minimize outward radiation, the model's exterior boundaries are configured with a scattering boundary condition.

Results and Discussion

The primary output of the simulation is the induced electric fields in adjacent wind turbines resulting from a lightning strike on one of the turbines, as illustrated in [Figure 2](#). These electric fields shed light on potential overvoltages and transient effects that could impact neighboring turbines. Examining the distribution and magnitude of these induced fields helps identify vulnerable zones within the wind farm layout. [Figure 2](#) focuses on the visual representation of these fields. For a more quantitative evaluation, [Figure 3](#) contrasts the norm of the electric field at a vertex near the tip of the blades across each turbine tower.

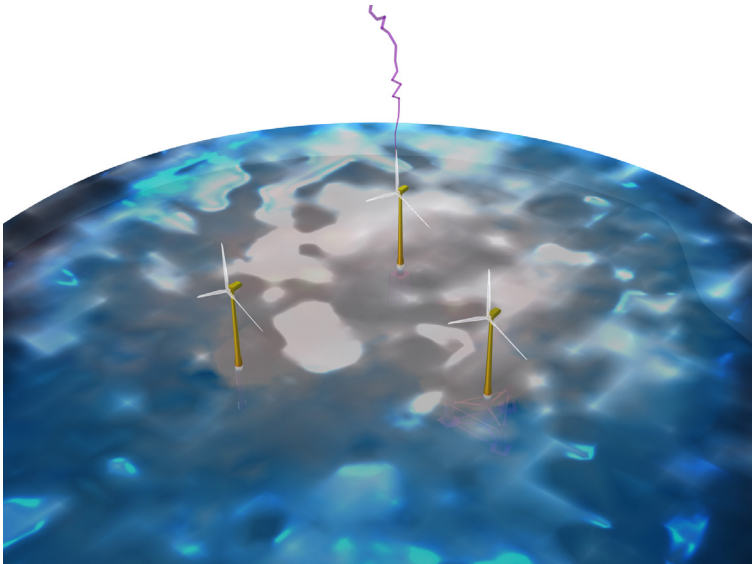

Figure 2: The norm of electric field on the turbine towers, sea water, and sea bed at $5 \mu s$.

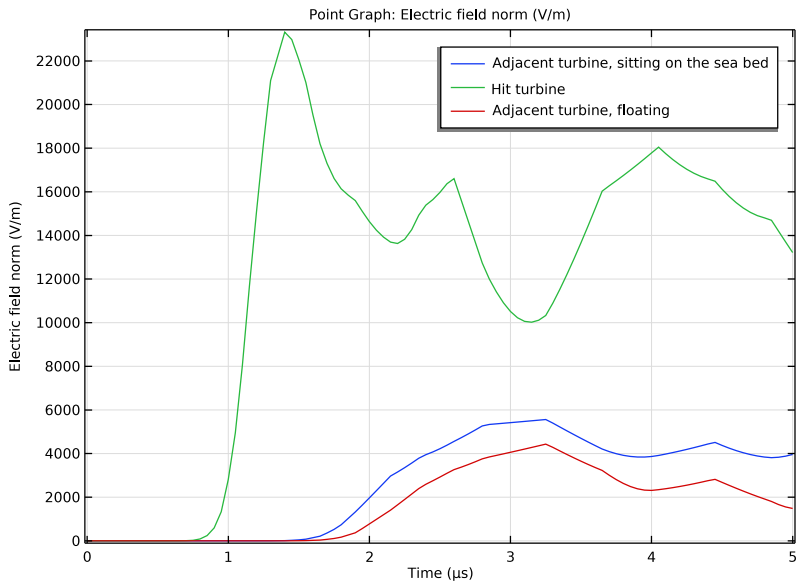

Figure 3: The norm of electric field on area around the tip of the blades at each tower.

Notes About the COMSOL Implementation

The model is designed for demonstration and emphasizes minimal computational resource use. Linear discretization is employed to lower computational costs.

Application Library path: RF_Module/ESD_and_Lightning_Surge/
lightning_surge_wind_farm



Modeling Instructions

From the **File** menu, choose **New**.

NEW





In the **New** window, click  **Model Wizard**.

MODEL WIZARD

- 1 In the **Model Wizard** window, click  **3D**.
- 2 In the **Select Physics** tree, select **Radio Frequency > Electromagnetic Waves, Transient (temw)**.
- 3 Click **Add**.
- 4 Click  **Study**.
- 5 In the **Select Study** tree, select **General Studies > Time Dependent**.
- 6 Click  **Done**.

GEOMETRY 1

Wind Turbine Tower

- 1 In the **Geometry** toolbar, click  **Import**.
- 2 In the **Settings** window for **Import**, type Wind Turbine Tower in the **Label** text field.
- 3 Locate the **Source** section. Click  **Browse**.
- 4 Browse to the model's Application Libraries folder and double-click the file lightning_surge_wind_farm_turbine_tower.mphbin.
- 5 Click  **Import**.
- 6 Click  **Build Selected**.

7 Click the  **Wireframe Rendering** button in the **Graphics** toolbar.

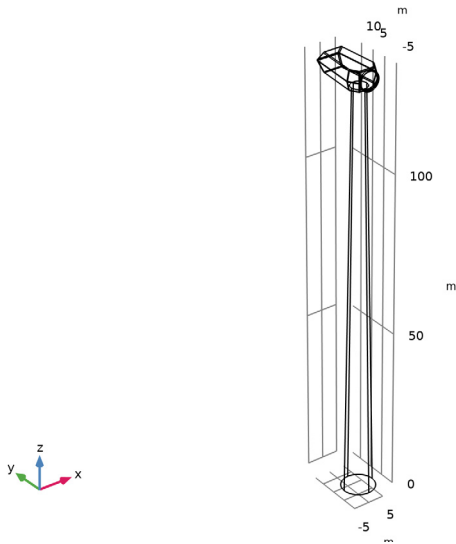

8 Locate the **Selections of Resulting Entities** section. Find the **Cumulative selection** subsection. Click **New**.

9 In the **New Cumulative Selection** dialog, type **Steel Body** in the **Name** text field.

10 Click **OK**.

Wind Turbine Blades

1 In the **Geometry** toolbar, click  **Import**.

2 In the **Settings** window for **Import**, type **Wind Turbine Blades** in the **Label** text field.

3 Locate the **Source** section. Click  **Browse**.



4 Browse to the model's **Application Libraries** folder and double-click the file `lightning_surge_wind_farm_turbine_blades.mphbin`.

5 Click  **Import**.

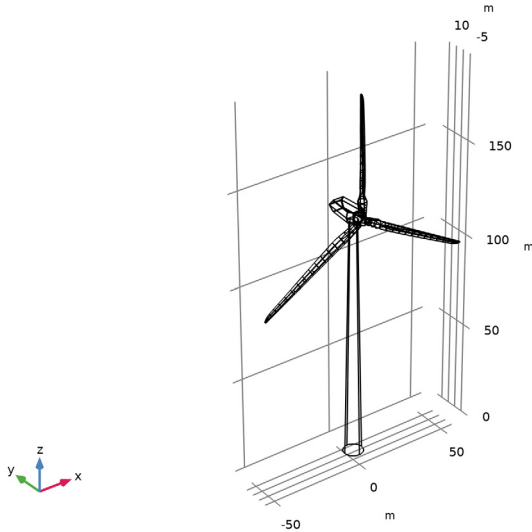
6 Click  **Build Selected.**



Inner Strip

- 1 In the **Geometry** toolbar, click  **Import.**
- 2 In the **Settings** window for **Import**, type Inner Strip in the **Label** text field.
- 3 Locate the **Source** section. Click  **Browse.**
- 4 Browse to the model's Application Libraries folder and double-click the file lightning_surge_wind_farm_inner_strip.mphbin.
- 5 Click  **Import.**
- 6 Click  **Build Selected.**

7 Click the  **Zoom Extents** button in the **Graphics** toolbar.

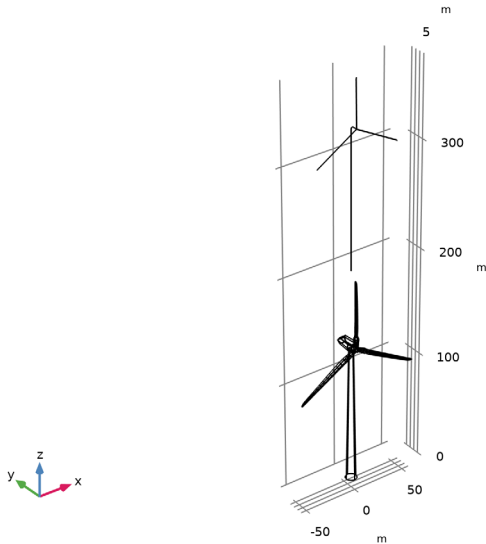

8 Locate the **Selections of Resulting Entities** section. Find the **Cumulative selection** subsection. Click **New**.

9 In the **New Cumulative Selection** dialog, type Down Conductors in the **Name** text field.

10 Click **OK**.

Supporting Structure

1 In the **Geometry** toolbar, click  **Import**.

2 In the **Settings** window for **Import**, type Supporting Structure in the **Label** text field.

3 Locate the **Source** section. Click  **Browse**.

4 Browse to the model's Application Libraries folder and double-click the file lightning_surge_wind_farm_turbine_support1.mphbin.

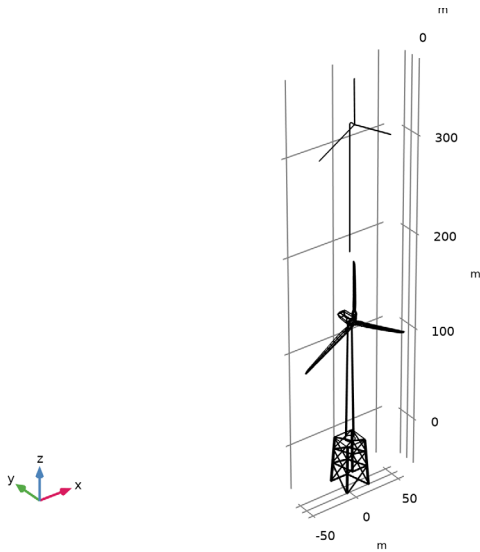

5 Click  **Import**.

6 Click  **Build Selected**.



7 Locate the **Selections of Resulting Entities** section. Find the **Cumulative selection** subsection. From the **Contribute to** list, choose **Steel Body**.

Floating Supporting Structure

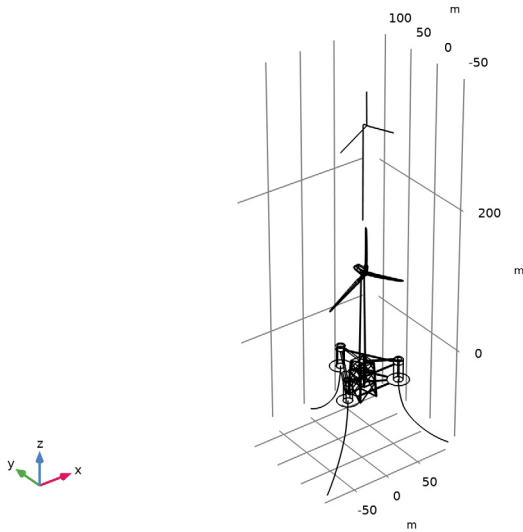

- 1 In the **Geometry** toolbar, click  **Import**.
- 2 In the **Settings** window for **Import**, type Floating Supporting Structure in the **Label** text field.
- 3 Locate the **Source** section. Click  **Browse**.
- 4 Browse to the model's Application Libraries folder and double-click the file lightning_surge_wind_farm_turbine_support2.mphbin.
- 5 Click  **Import**.

6 Click  **Build Selected**.



7 Locate the **Selections of Resulting Entities** section. Find the **Cumulative selection** subsection. From the **Contribute to** list, choose **Steel Body**.



Water and Seabed Surfaces

- 1 In the **Geometry** toolbar, click  **Import**.
- 2 In the **Settings** window for **Import**, type **Water** and **Seabed Surfaces** in the **Label** text field.
- 3 Locate the **Source** section. Click  **Browse**.
- 4 Browse to the model's **Application Libraries** folder and double-click the file **lightning_surge_wind_farm_water.mphbin**.
- 5 Click  **Import**.

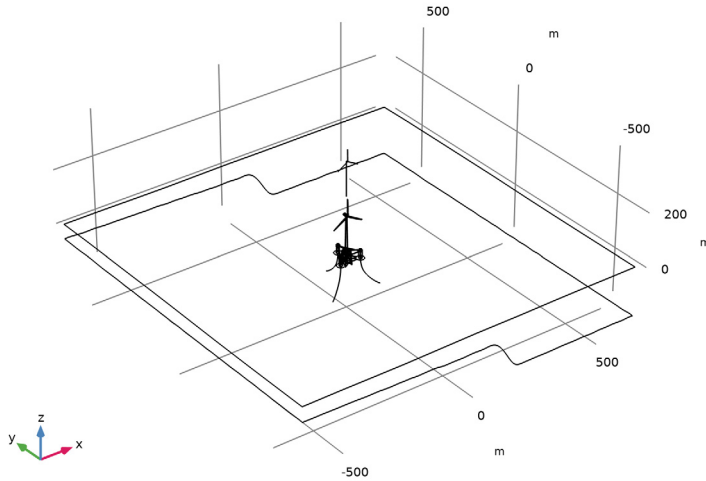

6 Click  **Build Selected.**



Move 1 (mov1)

- 1 In the **Geometry** toolbar, click  **Transforms** and choose **Move**.
- 2 Select the object **imp5** only.
- 3 In the **Settings** window for **Move**, locate the **Displacement** section.
- 4 In the **x** text field, type $300/\sqrt{3}$.
- 5 Click  **Build Selected.**

Move 2 (mov2)

- 1 In the **Geometry** toolbar, click  **Transforms** and choose **Move**.
- 2 Select the object **imp3** only.
- 3 In the **Settings** window for **Move**, locate the **Displacement** section.
- 4 In the **z** text field, type -200.
- 5 Click  **Build Selected.**

Move 3 (mov3)

- 1 In the **Geometry** toolbar, click  **Transforms** and choose **Move**.
- 2 Select the object **imp4** only.
- 3 In the **Settings** window for **Move**, locate the **Displacement** section.
- 4 In the **x** text field, type $-150/\sqrt{3}$.

5 In the **y** text field, type 150.

6 Click  **Build Selected**.

Cylinder 1 (cyl1)

1 In the **Geometry** toolbar, click  **Cylinder**.

2 In the **Settings** window for **Cylinder**, locate the **Size and Shape** section.

3 In the **Radius** text field, type 5.

4 In the **Height** text field, type 50.

5 Locate the **Position** section. In the **x** text field, type $-150/\sqrt{3}$.

6 In the **y** text field, type -150.

7 In the **z** text field, type -50.

8 Locate the **Selections of Resulting Entities** section. Find the **Cumulative selection** subsection. From the **Contribute to** list, choose **Steel Body**.

9 Click  **Build Selected**.

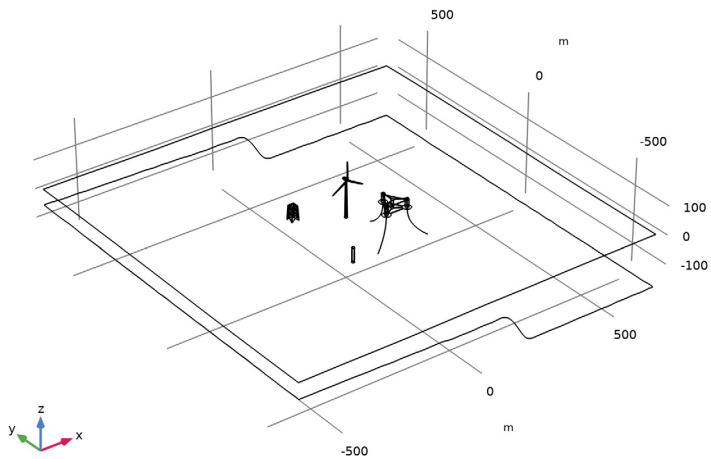



Copy 1 (copy1)

1 In the **Geometry** toolbar, click  **Transforms** and choose **Copy**.

2 Click the  **Select Box** button in the **Graphics** toolbar.



3 Select the objects **imp1**, **imp2**, and **mov2** only.

4 In the **Settings** window for **Copy**, locate the **Displacement** section.

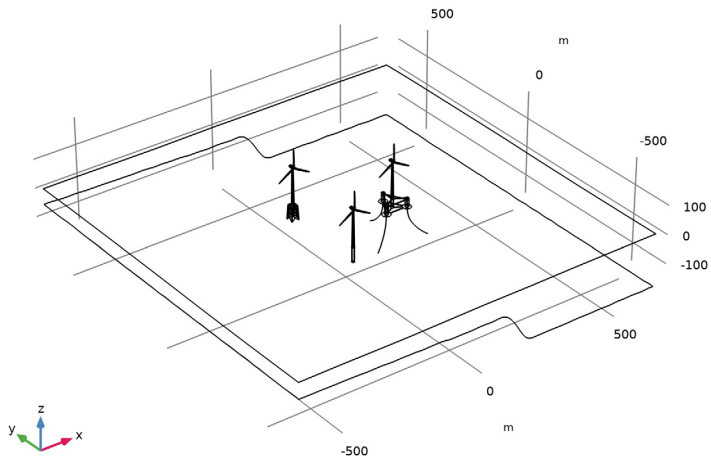
- 5 In the **x** text field, type $-150/\sqrt{3}$.
- 6 Locate the **Input** section. Clear the **Keep input objects** checkbox.
- 7 Locate the **Displacement** section. In the **x** text field, type $-150/\sqrt{3}$ $-150/\sqrt{3}$ $300/\sqrt{3}$.
- 8 In the **y** text field, type -150 150 0 .
- 9 Click  **Build Selected**.
- 10 Click the  **Zoom Extents** button in the **Graphics** toolbar.



Leader Channel

- 1 In the **Geometry** toolbar, click  **More Primitives** and choose **Polygon**.
- 2 In the **Settings** window for **Polygon**, type *Leader Channel* in the **Label** text field.
- 3 Locate the **Coordinates** section. Click  **Load from File**.
- 4 Browse to the model's Application Libraries folder and double-click the file `lightning_surge_wind_farm_table.txt`.

5 Click  **Build Selected**.

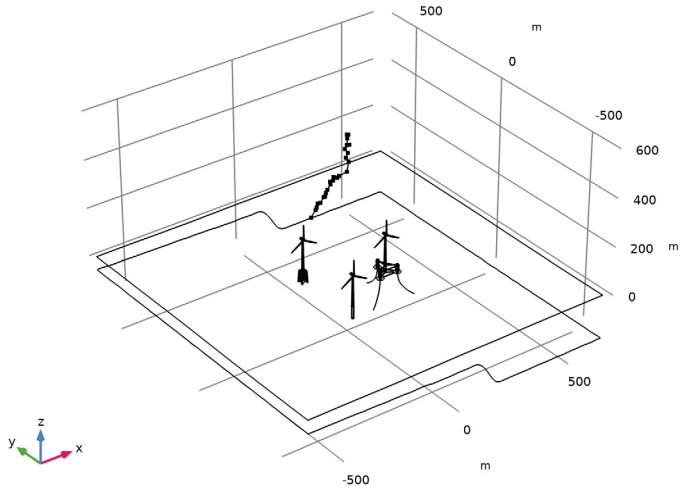

6 Locate the **Selections of Resulting Entities** section. Find the **Cumulative selection** subsection. Click **New**.

7 In the **New Cumulative Selection** dialog, type **Lightning Channel** in the **Name** text field.

8 Click **OK**.

Final Strike

1 In the **Geometry** toolbar, click  **More Primitives** and choose **Line Segment**.

2 In the **Settings** window for **Line Segment**, type **Final Strike** in the **Label** text field.

3 On the object **poll**, select Point 1 only.

4 Locate the **Endpoint** section. Click to select the  **Activate Selection** toggle button for **End vertex**.

5 On the object **copy1(5)**, select Point 273 only.

6 Locate the **Selections of Resulting Entities** section. Find the **Cumulative selection** subsection. From the **Contribute to** list, choose **Lightning Channel**.

7 Click  **Build Selected.**

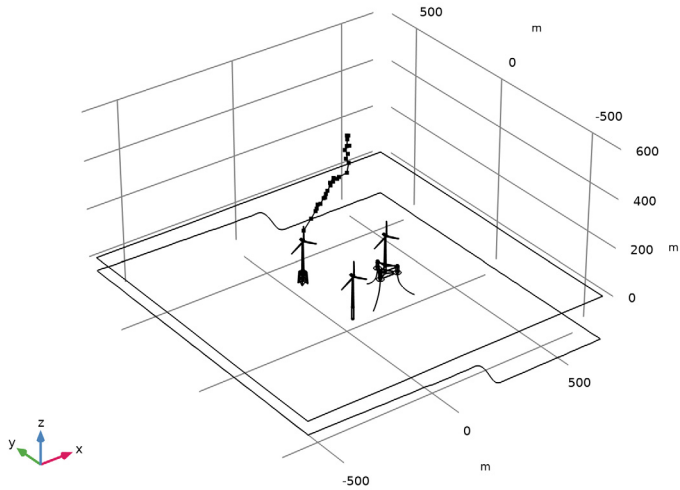



Cylinder 2 (cyl2)

- 1 In the **Geometry** toolbar, click  **Cylinder**.
- 2 In the **Settings** window for **Cylinder**, locate the **Size and Shape** section.
- 3 In the **Radius** text field, type 600.
- 4 In the **Height** text field, type 1000.
- 5 Locate the **Position** section. In the **z** text field, type -300.

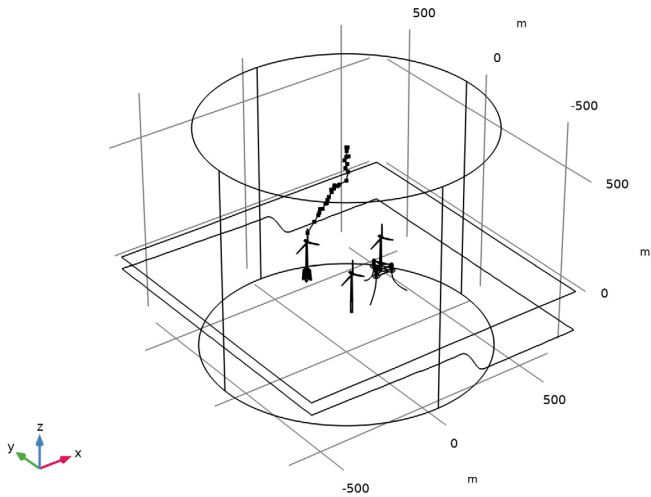
6 Click  **Build Selected**.



Partition Objects 1 (part 1)

- 1 In the **Geometry** toolbar, click  **Booleans and Partitions** and choose **Partition Objects**.
- 2 Select the object **imp6** only.
- 3 In the **Settings** window for **Partition Objects**, locate the **Partition Objects** section.
- 4 Click to select the  **Activate Selection** toggle button for **Tool objects**.
- 5 Select the object **cyl2** only.
- 6 Select the **Keep tool objects** checkbox.
- 7 Click  **Build Selected**.

Delete Entities 1 (del1)

1 In the **Model Builder** window, right-click **Geometry 1** and choose **Delete Entities**.

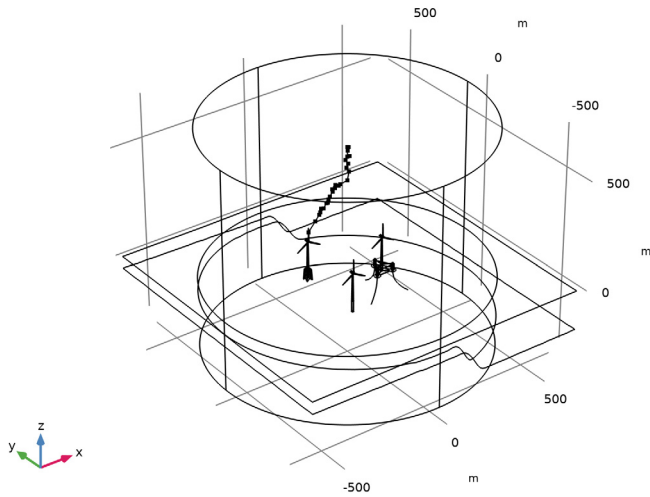

2 On the object **par1**, select Boundaries 1 and 2 only.

3 In the **Geometry** toolbar, click  **Build All**.

4 In the **Model Builder** window, click **Geometry I**.

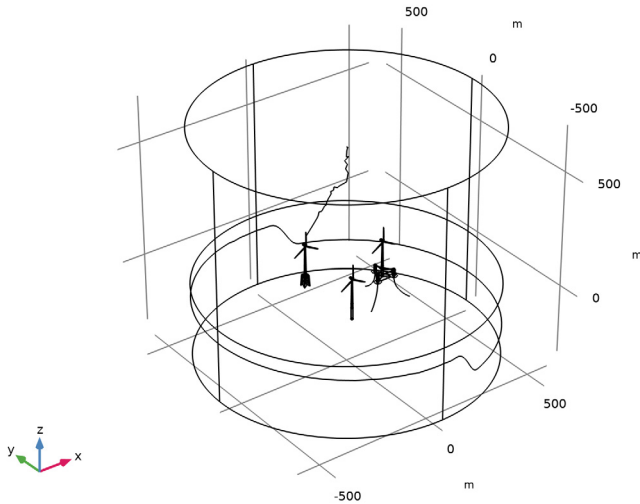

Disable the analysis of the geometry as the remaining small geometric details can be kept.

5 In the **Model Builder** window, click **Geometry I**.

6 In the **Settings** window for **Geometry**, locate the **Cleanup** section.

7 Clear the **Automatic detection of small details** checkbox.

ADD MATERIAL

1 In the **Home** toolbar, click  **Add Material** to open the **Add Material** window.

2 Go to the **Add Material** window.

3 In the tree, select **Built-in > Air**.

4 Click the **Add to Component** button in the window toolbar.

5 In the **Home** toolbar, click  **Add Material** to close the **Add Material** window.

MATERIALS

Sea Water

1 In the **Model Builder** window, under **Component I (comp1)** right-click **Materials** and choose **Blank Material**.

2 In the **Settings** window for **Material**, type *Sea Water* in the **Label** text field.

3 Select Domain 2 only.

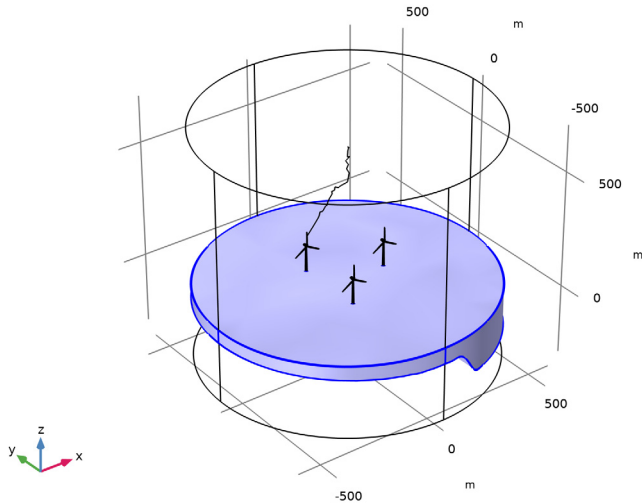

4 Locate the **Material Contents** section. In the table, enter the following settings:

Property	Variable	Value	Unit	Property group
Relative permittivity	epsilon _{nr_ii} ; epsilon _{nr_ii} = epsilon _{nr_ii} , epsilon _{nr_ij} = 0	80		Basic
Relative permeability	mu _{r_ii} ; mu _{r_ii} ; mu _{r_ii} = mu _{r_ii} , mu _{r_ij} = 0	1		Basic
Electric conductivity	sigma _{ii} ; sigma _{ii} = sigma _{ii} , sigma _{ij} = 0	4	S/m	Basic

Sea Bed

1 Right-click **Materials** and choose **Blank Material**.

2 Select Domain 1 only.

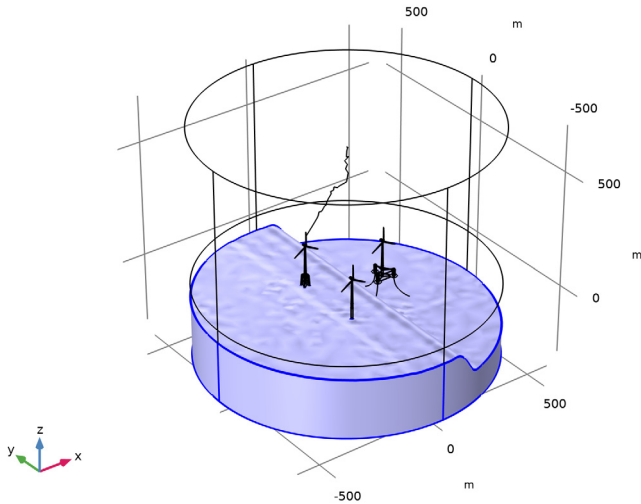

3 In the **Settings** window for **Material**, type **Sea Bed** in the **Label** text field.

4 Locate the **Material Contents** section. In the table, enter the following settings:

Property	Variable	Value	Unit	Property group
Relative permittivity	epsilon _{nr_} iso ; epsilon _{nrii} = epsilon _{nr_} iso, epsilon _{nrij} = 0	15		Basic
Relative permeability	mu _{r_} iso ; mu _{rii} = mu _{r_} iso, mu _{rij} = 0	1		Basic
Electric conductivity	sigma __ iso ; sigma _{ii} = sigma __ iso, sigma _{ij} = 0	0.1	S/m	Basic

Use the **Linear** discretization to reduce computational costs, though this might compromise accuracy. The model is designed for demonstration with an emphasis on minimizing computational resources.

ELECTROMAGNETIC WAVES, TRANSIENT (TEMW)

- 1 In the **Model Builder** window, under **Component 1 (comp1)** click **Electromagnetic Waves, Transient (temw)**.
- 2 In the **Settings** window for **Electromagnetic Waves, Transient**, click to expand the **Discretization** section.
- 3 From the **Magnetic vector potential** list, choose **Linear**.

Edge Current I

- 1 In the **Physics** toolbar, click  **Edges** and choose **Edge Current**.
- 2 In the **Settings** window for **Edge Current**, locate the **Edge Selection** section.
- 3 From the **Selection** list, choose **Lightning Channel**.

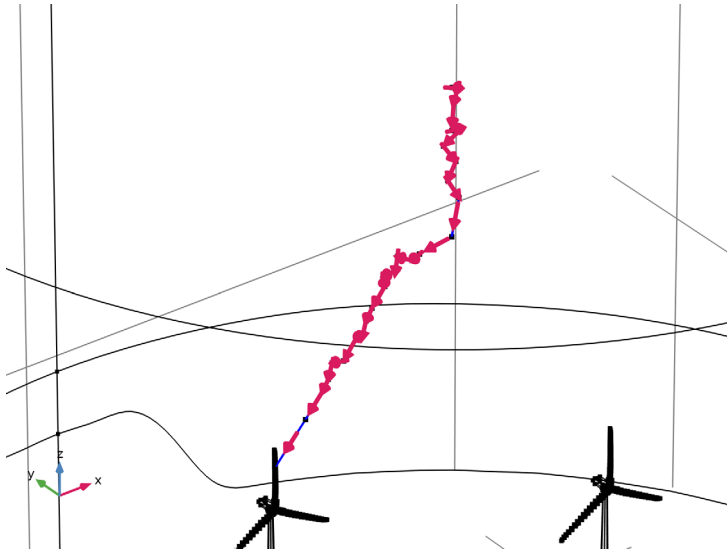

- 4 Locate the **Edge Current** section. From the **Edge current type** list, choose **Lightning**.
- 5 In the I_0 text field, type 20[kA].
- 6 In the τ_1 text field, type 0.8[us].
- 7 In the τ_2 text field, type 80[us].
- 8 In the v_p text field, type $c_const/3$.
- 9 Select the **Reverse direction** checkbox.

10 Click the **Plot Pulse Shape** button in the window toolbar.

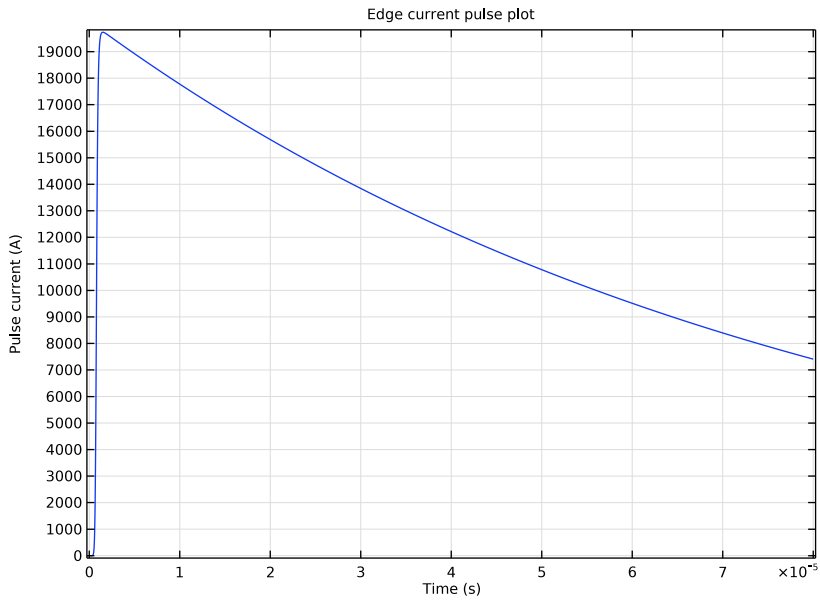

ELECTROMAGNETIC WAVES, TRANSIENT (TEMW)

Perfect Electric Conductor 2

- 1 In the **Model Builder** window, expand the **Component 1 (comp1) > Definitions** node.
- 2 Right-click **Component 1 (comp1) > Electromagnetic Waves, Transient (temw)** and choose **Perfect Electric Conductor**.
- 3 In the **Settings** window for **Perfect Electric Conductor**, locate the **Boundary Selection** section.

4 From the **Selection** list, choose **Steel Body**.

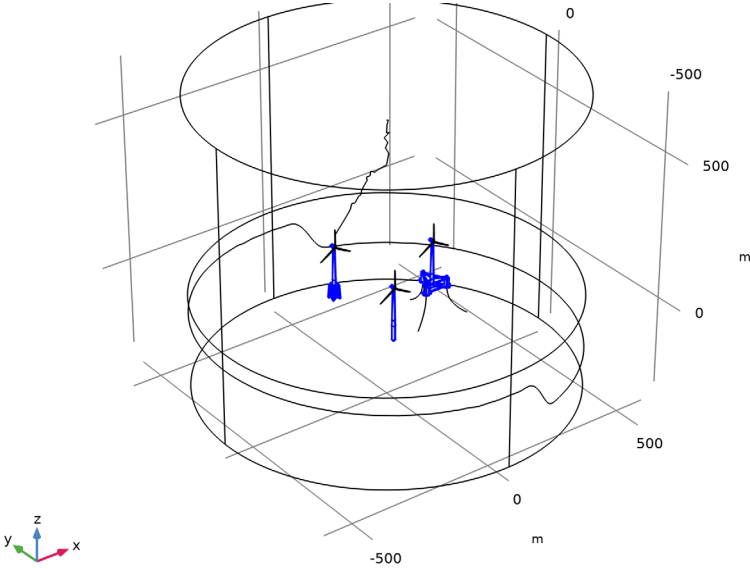

Perfect Electric Conductor 3

I In the **Physics** toolbar, click  **Boundaries** and choose **Perfect Electric Conductor**.

2 Select Boundary 667 only.

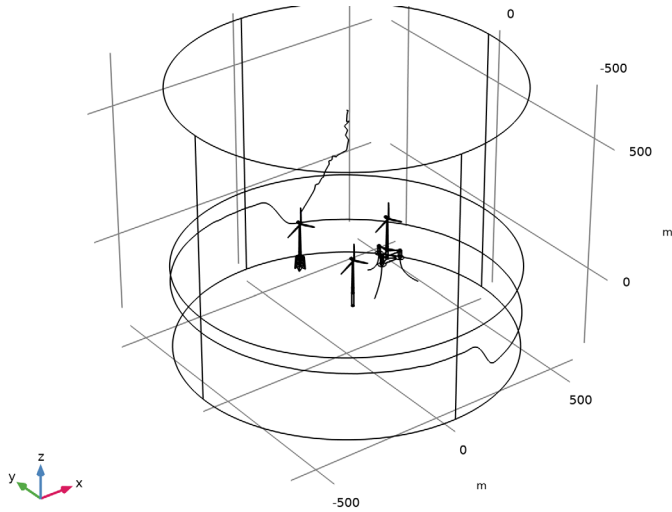

3 Click the  **Go to Default View** button in the **Graphics** toolbar.

Perfect Electric Conductor 4



1 In the **Physics** toolbar, click  **Boundaries** and choose **Perfect Electric Conductor**.

2 In the **Settings** window for **Perfect Electric Conductor**, locate the **Boundary Selection** section.

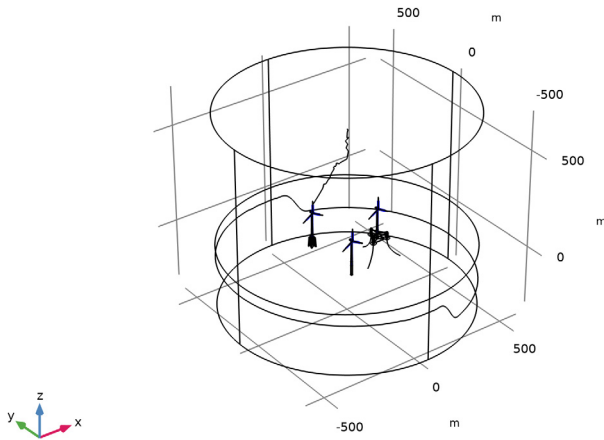
3 From the **Selection** list, choose **Down Conductors**.



Scattering Boundary Condition 1

- 1 In the **Physics** toolbar, click  **Boundaries** and choose **Scattering Boundary Condition**.
- 2 Click the  **Orthographic Projection** button in the **Graphics** toolbar.
- 3 Select Boundaries 1–5, 7, 8, 10, and 1262–1267 only.

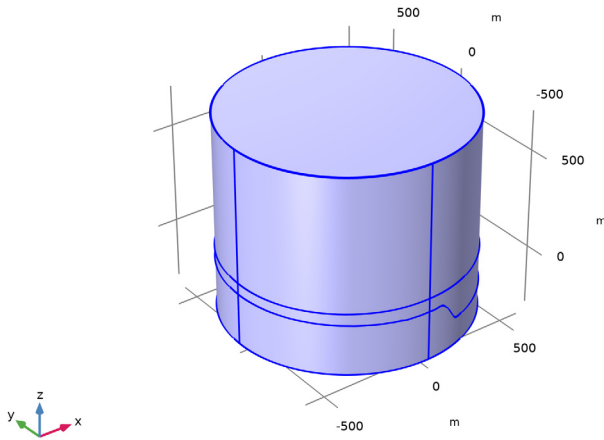

DEFINITIONS

Hide for Physics I

- 1 In the **Model Builder** window, right-click **View I** and choose **Hide for Physics**.
- 2 In the **Settings** window for **Hide for Physics**, locate the **Geometric Entity Selection** section.
- 3 From the **Geometric entity level** list, choose **Boundary**.
- 4 Select Boundaries 4, 7, 10, 1259, and 1260 only.

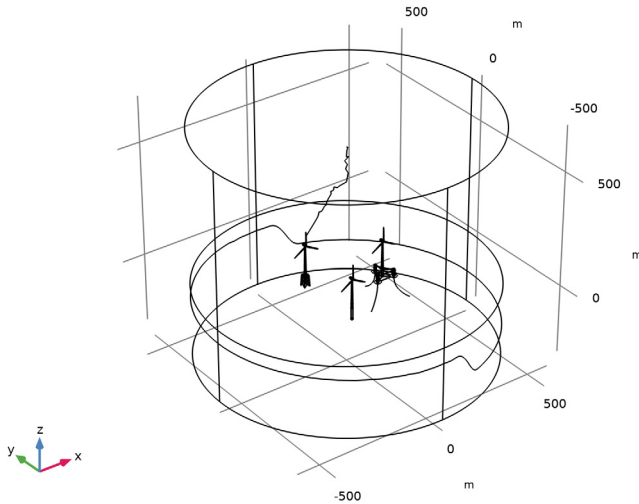

MESH I

- 1 In the **Model Builder** window, under **Component I (comp1)** click **Mesh I**.
- 2 In the **Settings** window for **Mesh**, locate the **Electromagnetic Waves, Transient (temw)** section.
- 3 In the **Maximum element size in free space** text field, type 120.
- 4 Click  **Build All**.
Make the mesh coarse in the area where the wave propagation is not of interest such as the sea water.
- 5 In the **Settings** window for **Mesh**, locate the **Sequence Type** section.
- 6 From the list, choose **User-controlled mesh**.

Size

- 1 In the **Model Builder** window, under **Component I (comp1)** > **Mesh I** click **Size**.

- 2 In the **Settings** window for **Size**, locate the **Element Size Parameters** section.
- 3 In the **Maximum element size** text field, type 60.
- 4 In the **Minimum element size** text field, type 20.

Size 1

- 1 In the **Model Builder** window, click **Size 1**.
- 2 In the **Settings** window for **Size**, locate the **Element Size Parameters** section.
- 3 In the **Maximum element size** text field, type 40.
- 4 In the **Minimum element size** text field, type 20.

Size 2

- 1 In the **Model Builder** window, click **Size 2**.
- 2 In the **Settings** window for **Size**, locate the **Element Size Parameters** section.
- 3 In the **Maximum element size** text field, type 30.
- 4 In the **Minimum element size** text field, type 20.
- 5 Click  **Build All**.

STUDY 1

Step 1: Time Dependent

- 1 In the **Model Builder** window, under **Study 1** click **Step 1: Time Dependent**.
- 2 In the **Settings** window for **Time Dependent**, locate the **Study Settings** section.
- 3 From the **Time unit** list, choose **μs**.
- 4 In the **Output times** text field, type range (0,0.05,5).
- 5 In the **Study** toolbar, click  **Compute**.

RESULTS

Transparency 1

- 1 In the **Model Builder** window, expand the **3D Plot Group 1** node.

2 Right-click **Multislice 1** and choose **Transparency**.

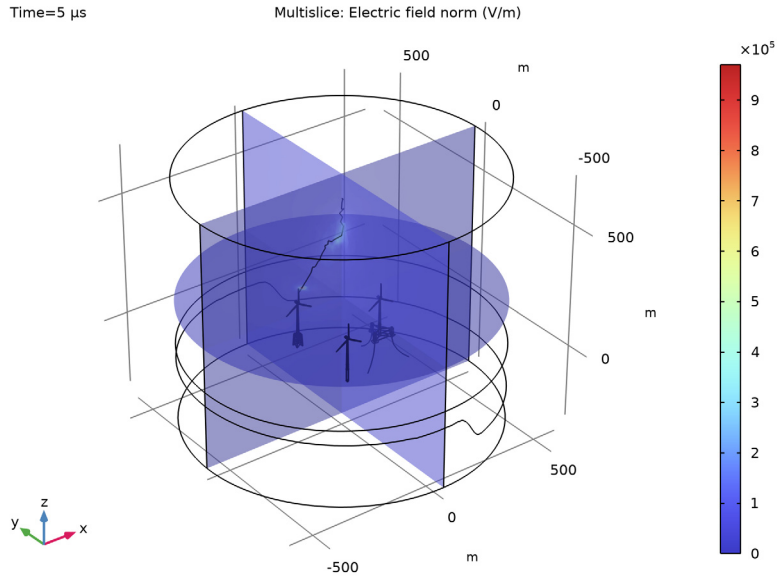

3D Plot Group 2

In the **Results** toolbar, click  **3D Plot Group**.

Sea Water

- 1** Right-click **3D Plot Group 2** and choose **Volume**.
- 2** In the **Settings** window for **Volume**, type **Sea Water** in the **Label** text field.
- 3** Click to expand the **Range** section. Select the **Manual color range** checkbox.
- 4** In the **Maximum** text field, type **1**.
- 5** Locate the **Coloring and Style** section. From the **Color table** list, choose **JupiterAuroraBorealis**.

Selection 1

- 1** Right-click **Sea Water** and choose **Selection**.
- 2** Select Domain 2 only.

Material Appearance 1

- 1** In the **Model Builder** window, right-click **Sea Water** and choose **Material Appearance**.
- 2** In the **Settings** window for **Material Appearance**, locate the **Appearance** section.
- 3** From the **Appearance** list, choose **Custom**.

- 4 From the **Material type** list, choose **Water**.
- 5 Locate the **Color** section. Select the **Use the plot's color** checkbox.

Transparency 1

Right-click **Sea Water** and choose **Transparency**.

Sea Bed

- 1 In the **Model Builder** window, right-click **3D Plot Group 2** and choose **Volume**.
- 2 In the **Settings** window for **Volume**, type Sea Bed in the **Label** text field.
- 3 Locate the **Coloring and Style** section. From the **Color table** list, choose **GrayBody**.

Selection 1

- 1 Right-click **Sea Bed** and choose **Selection**.
- 2 Select Domain 1 only.

Material Appearance 1

- 1 In the **Model Builder** window, right-click **Sea Bed** and choose **Material Appearance**.
- 2 In the **Settings** window for **Material Appearance**, locate the **Appearance** section.
- 3 From the **Appearance** list, choose **Custom**.
- 4 From the **Material type** list, choose **Soil**.
- 5 Locate the **Color** section. Select the **Use the plot's color** checkbox.

Wind Turbine Body

- 1 In the **Model Builder** window, right-click **3D Plot Group 2** and choose **Surface**.
- 2 In the **Settings** window for **Surface**, type Wind Turbine Body in the **Label** text field.
- 3 Locate the **Coloring and Style** section. From the **Color table** list, choose **Plasma**.
- 4 From the **Scale** list, choose **Logarithmic**.

Selection 1

- 1 Right-click **Wind Turbine Body** and choose **Selection**.
- 2 In the **Settings** window for **Selection**, locate the **Selection** section.
- 3 From the **Selection** list, choose **Steel Body**.

Material Appearance 1

- 1 In the **Model Builder** window, right-click **Wind Turbine Body** and choose **Material Appearance**.
- 2 In the **Settings** window for **Material Appearance**, locate the **Appearance** section.
- 3 From the **Appearance** list, choose **Custom**.

- 4 From the **Material type** list, choose **Steel (anodized)**.
- 5 Locate the **Color** section. Select the **Use the plot's color** checkbox.

Down Conductors

- 1 In the **Model Builder** window, right-click **3D Plot Group 2** and choose **Surface**.
- 2 In the **Settings** window for **Surface**, type **Down Conductors** in the **Label** text field.

Selection 1

- 1 Right-click **Down Conductors** and choose **Selection**.
- 2 In the **Settings** window for **Selection**, locate the **Selection** section.
- 3 From the **Selection** list, choose **Down Conductors**.

Material Appearance 1

- 1 In the **Model Builder** window, right-click **Down Conductors** and choose **Material Appearance**.
- 2 In the **Settings** window for **Material Appearance**, locate the **Appearance** section.
- 3 From the **Appearance** list, choose **Custom**.
- 4 From the **Material type** list, choose **Gold**.
- 5 Locate the **Color** section. Select the **Use the plot's color** checkbox.

Lightning Channel

- 1 In the **Model Builder** window, right-click **3D Plot Group 2** and choose **Line**.
- 2 In the **Settings** window for **Line**, locate the **Coloring and Style** section.
- 3 From the **Line type** list, choose **Tube**.
- 4 In the **Tube radius expression** text field, type $\sqrt{z-175}$.
- 5 Select the **Radius scale factor** checkbox. In the associated text field, type 0.1.
- 6 From the **Scale** list, choose **Logarithmic**.
- 7 From the **Color table** list, choose **Plasma**.
- 8 In the **Label** text field, type **Lightning Channel**.

Selection 1

- 1 Right-click **Lightning Channel** and choose **Selection**.
- 2 In the **Settings** window for **Selection**, locate the **Selection** section.
- 3 From the **Selection** list, choose **Lightning Channel**.
- 4 In the **3D Plot Group 2** toolbar, click  **Plot**.

Transparency 1

- 1 In the **Model Builder** window, right-click **Lightning Channel** and choose **Transparency**.
- 2 In the **Settings** window for **Transparency**, locate the **Transparency** section.
- 3 Set the **Transparency** value to **0.65**.

3D Plot Group 2

- 1 In the **Model Builder** window, under **Results** click **3D Plot Group 2**.
- 2 In the **Settings** window for **3D Plot Group**, locate the **Plot Settings** section.
- 3 Clear the **Plot dataset edges** checkbox.

Blades

- 1 Right-click **3D Plot Group 2** and choose **Volume**.
- 2 In the **Settings** window for **Volume**, type **Blades** in the **Label** text field.
- 3 Locate the **Expression** section. In the **Expression** text field, type **1**.

Selection 1

- 1 Right-click **Blades** and choose **Selection**.
- 2 Select Domains **4**, **5**, and **22** only.

Material Appearance 1

- 1 In the **Model Builder** window, right-click **Blades** and choose **Material Appearance**.
- 2 In the **Settings** window for **Material Appearance**, locate the **Appearance** section.
- 3 From the **Appearance** list, choose **Custom**.
- 4 In the **3D Plot Group 2** toolbar, click  **Plot**.

Transparency 1

- 1 Right-click **Blades** and choose **Transparency**.

2 Click the  **Show Legends** button in the **Graphics** toolbar.

Time=5 μ s Volume: Electric field norm (V/m) Volume: Electric field norm (V/m) Surface: Electric field norm (V/m) Surface: Electric field norm (V/m) Line: Electric field norm (V/m) Volume: 1 (1)

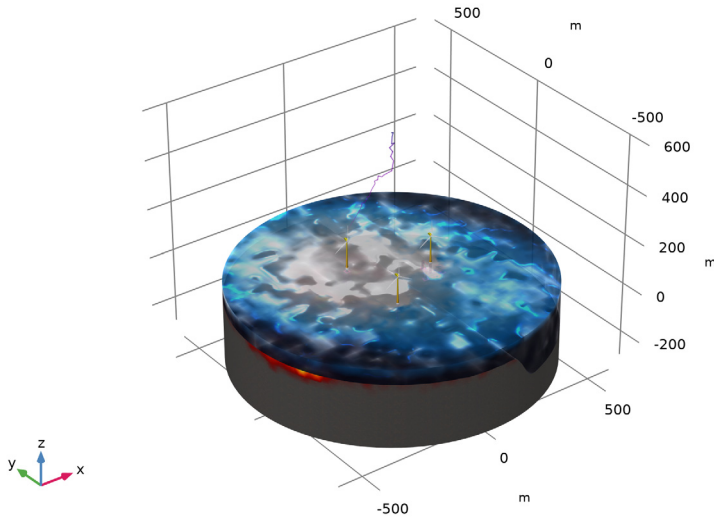

By adjusting the 3D camera settings, add more visual impact.

DEFINITIONS

Camera

- 1 In the **Model Builder** window, under **Component 1 (comp1) > Definitions > View 1** click **Camera**.
- 2 In the **Settings** window for **Camera**, locate the **Camera** section.
- 3 In the **Zoom angle** text field, type 35.
- 4 Locate the **Position** section. In the **x** text field, type 800.
- 5 In the **y** text field, type -900.
- 6 In the **z** text field, type 900.
- 7 Locate the **Target** section. In the **x** text field, type -4000.
- 8 In the **y** text field, type 5000.
- 9 In the **z** text field, type -4000.
- 10 Locate the **Up Vector** section. In the **x** text field, type -0.3.
- 11 In the **y** text field, type 0.35.

- 12 In the **z** text field, type 1.
- 13 Locate the **Center of Rotation** section. In the **x** text field, type -50.
- 14 In the **y** text field, type 80.
- 15 In the **z** text field, type 15.
- 16 Locate the **View Offset** section. In the **x** text field, type 0.05.
- 17 In the **y** text field, type 0.05.
- 18 Click  **Update**.

RESULTS

3D Plot Group 2

In the **Model Builder** window, under **Results** click **3D Plot Group 2**.

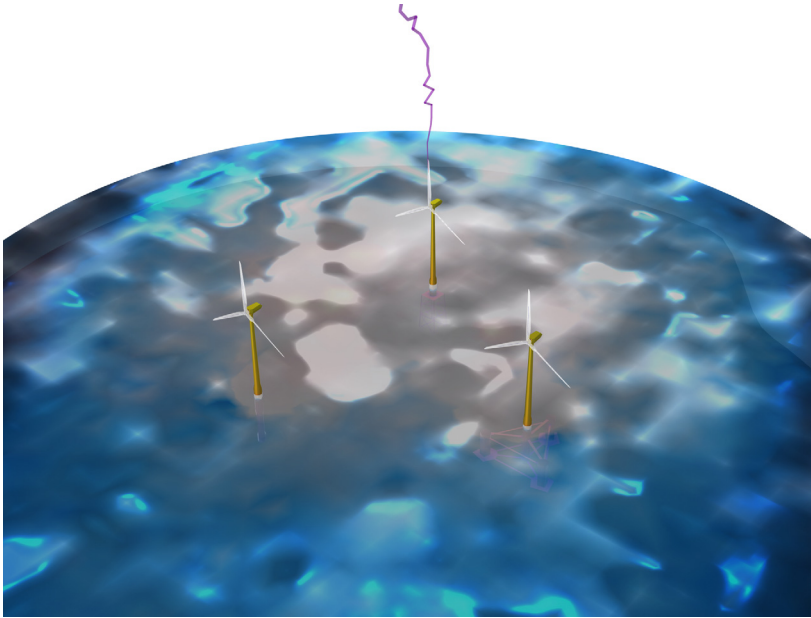

1D Plot Group 3



In the **Results** toolbar, click  **ID Plot Group**.

Point Graph 1

- 1 Right-click **ID Plot Group 3** and choose **Point Graph**.
- 2 Select Points 1560, 1561, and 2385 only.
- 3 In the **ID Plot Group 3** toolbar, click  **Plot**.

- 4 In the **Settings** window for **Point Graph**, locate the **Selection** section.
- 5 Click to select the **Activate Selection** toggle button.
- 6 In the list, select **2385**.
- 7 Click to expand the **Legends** section. From the **Legends** list, choose **Manual**.
- 8 In the table, enter the following settings:

Legends
Adjacent turbine, sitting on the sea bed
Hit turbine
Adjacent turbine, floating

- 9 In the **ID Plot Group 3** toolbar, click  **Plot**.
- 10 Select the **Show legends** checkbox.
- 11 In the **ID Plot Group 3** toolbar, click  **Plot**.

