



# Dipole Antenna with a Quarter-Wave Coaxial Balun

## Introduction

---

An antenna balun blocks undesirable currents on the outside of a cable. A quarter-wave coaxial balun (1:1) is one of the easiest designs: it works as a transformer and makes the input impedance from the inner conductor to the outer conductor infinite. This example simulates an antenna prototype including an SMA Receptacle, an ABS enclosure, and a quarter-wave coaxial balun. The frequency is tuned to GPS range, 1.57542 GHz. Such an antenna can be useful for indoor measurements with a single polarization.

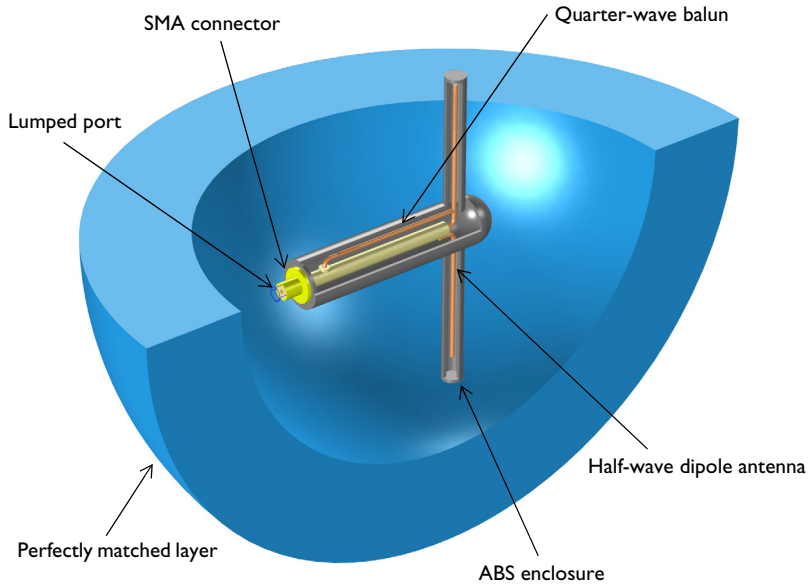

*Figure 1: A quarter-wave balun is added on a half-wave dipole antenna with an ABS enclosure. The entire domain is bounded by a perfectly matched layer.*

## Model Definition

---

The antenna model shown in [Figure 1](#) is composed of a half-wave dipole antenna connected to a coaxial cable, a SMA receptacle (connector), an antenna enclosure, and a perfectly matched layer (PML). Model all metal parts as perfect electric conductors (PEC). The space between the inner and outer conductors of the coaxial cable is filled with polytetrafluoroethylene (PTFE),  $\epsilon_r = 2.1$ . Furthermore, model the antenna enclosure

using acrylonitrile butadiene styrene (ABS), a plastic material with  $\epsilon_r = 2.4$ . The rest of the simulation domain is air and the entire simulation domain is enclosed by the PML.

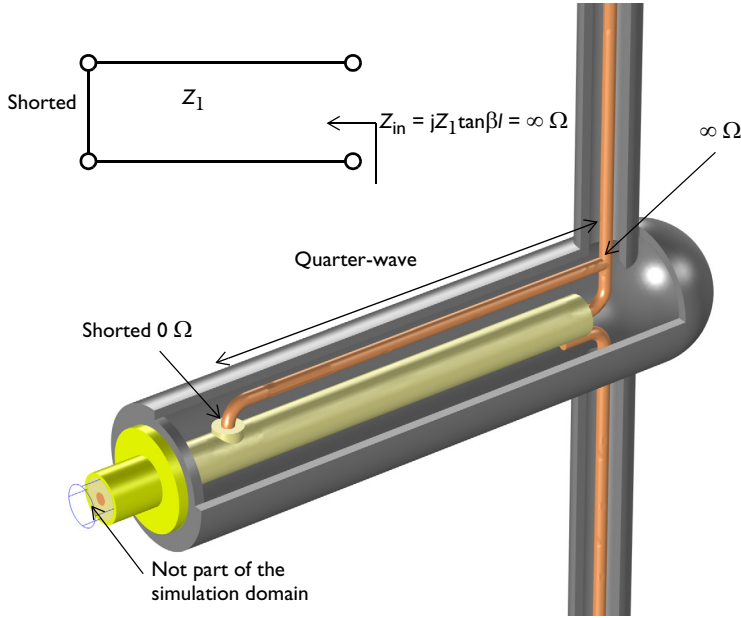

*Figure 2: Zoomed view of the antenna interior shows the configuration of the balun.*

The antenna balun part shown in [Figure 2](#) can be analyzed using the transmission line theory. The input impedance of the short-circuited transmission line is

$$Z_{in} = jZ_1 \tan \beta l$$

This can also be calculated via the quarter-wave transformer analysis:

$$Z_{in} = Z_1^2 / Z_l$$

The input impedance of the short-circuited quarter-wavelength transmission line is calculated as infinite from both equations. This infinite input impedance prevents a current flow or coupling from the antenna radiator to the outer conductor of the coaxial cable. Thus, the antenna radiators connected to the inherently unbalanced coaxial cable can be balanced without generating the current on an undesired location.

## Results and Discussion

The default plots after the simulation show the norm of the electric fields, 2D far-field polar plot, and 3D far-field radiation pattern. The symmetric and balanced E-fields excited on each antenna radiator are observed in [Figure 3](#).

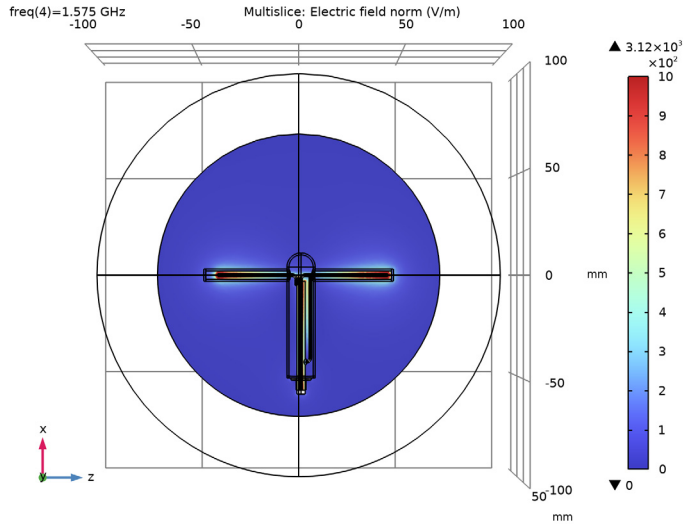

*Figure 3: The E-field norm on each antenna radiator looks symmetric.*

[Figure 4](#) shows the far-field radiation pattern on the H-plane. The pattern looks almost isotropic and omnidirectional. The magnitude of the far field is slightly decreased around  $180^\circ$  where the body of the antenna enclosure and connector are located. The 3D far-field radiation pattern is plotted in [Figure 5](#) and it is very like that of a conventional half-wave dipole antenna.

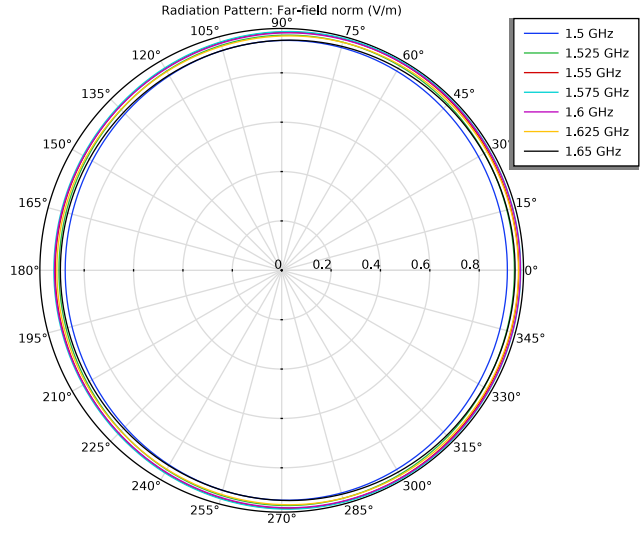

Figure 4: The far-field pattern on the H-plane is isotropic as expected.

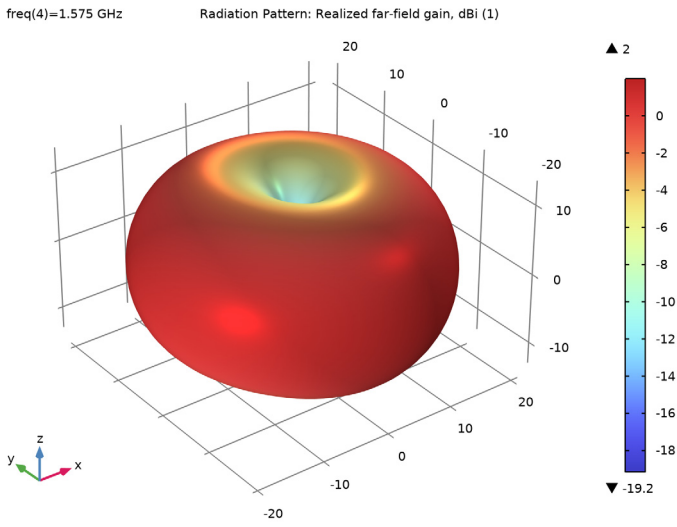

Figure 5: The visualized 3D far-field pattern is a little bit distorted due to the balun and the antenna enclosure.

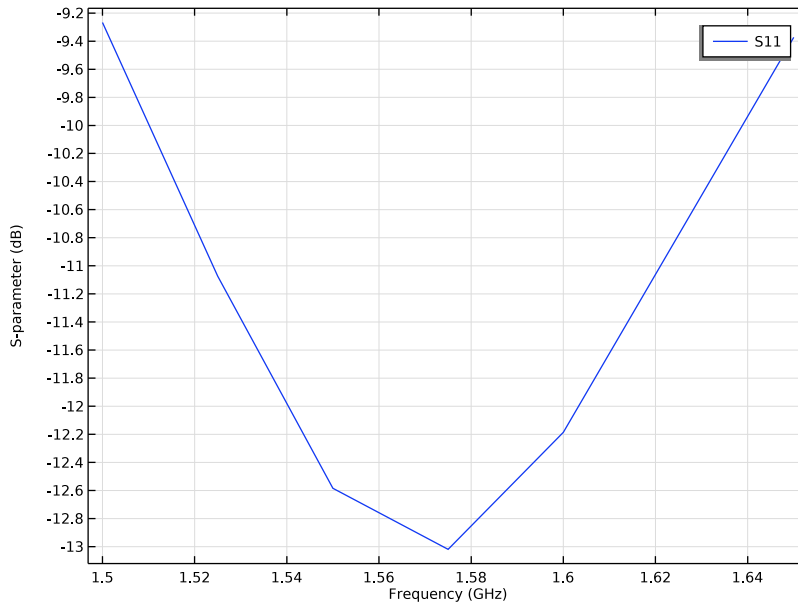

Figure 6: The S-parameter plot shows the antenna is resonant around the GPS frequency, 1.57542 GHz.

The calculated S-parameters plotted in Figure 6 are less than  $-10$  dB around the GPS frequency range.

### References

1. D.M. Pozar, *Microwave Engineering*, John Wiley & Sons, 1998.
2. C.A. Balanis, *Antenna Theory*, John Wiley & Sons, 1997.

---

**Application Library path:** RF\_Module/Antennas/dipole\_antenna\_balun

---



### Modeling Instructions

From the **File** menu, choose **New**.

## NEW

In the **New** window, click  **Model Wizard**.

## MODEL WIZARD

- 1 In the **Model Wizard** window, click .
- 2 In the **Select Physics** tree, select **Radio Frequency > Electromagnetic Waves, Frequency Domain (emw)**.
- 3 Click **Add**.
- 4 In the **Added physics interfaces** tree, select **Electromagnetic Waves, Frequency Domain (emw)**.
- 5 Click  **Study**.
- 6 In the **Select Study** tree, select **General Studies > Frequency Domain**.
- 7 Click  **Done**.

## STUDY I

### *Step 1: Frequency Domain*

Define the study frequency ahead of performing any frequency-dependent operation such as building mesh. The physics-controlled mesh uses the specified frequency value.

- 1 In the **Model Builder** window, under **Study I** click **Step 1: Frequency Domain**.
- 2 In the **Settings** window for **Frequency Domain**, locate the **Study Settings** section.
- 3 In the **Frequencies** text field, type range (1.5[GHz], 25[MHz], 1.65[GHz]).

## GLOBAL DEFINITIONS

### *Parameters 1*





- 1 In the **Model Builder** window, under **Global Definitions** click **Parameters 1**.
- 2 In the **Settings** window for **Parameters**, locate the **Parameters** section.
- 3 Click  **Load from File**.
- 4 Browse to the model's Application Libraries folder and double-click the file `dipole_antenna_balun_parameters.txt`.

## GEOMETRY I

- 1 In the **Model Builder** window, under **Component 1 (comp1)** click **Geometry 1**.
- 2 In the **Settings** window for **Geometry**, locate the **Units** section.
- 3 From the **Length unit** list, choose **mm**.

First, import the antenna enclosure structure.

*Import 1 (impl)*

- 1 In the **Geometry** toolbar, click  **Import**.
- 2 In the **Settings** window for **Import**, locate the **Source** section.
- 3 Click  **Browse**.
- 4 Browse to the model's Application Libraries folder and double-click the file `dipole_antenna_balun.mphbin`.
- 5 Click  **Import**.  
Choose wireframe rendering to see the interior of the enclosure.
- 6 Click the  **Wireframe Rendering** button in the **Graphics** toolbar.

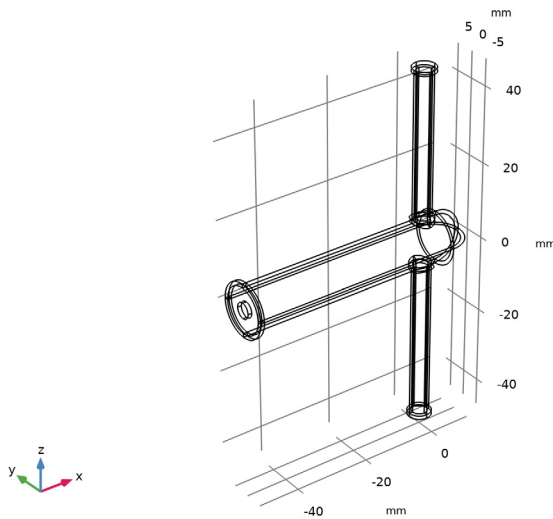

Add a cylinder for the inner conductor of the coaxial cable.

*Coax inner*

- 1 In the **Geometry** toolbar, click  **Cylinder**.
- 2 In the **Settings** window for **Cylinder**, type `Coax inner` in the **Label** text field.
- 3 Locate the **Size and Shape** section. In the **Radius** text field, type `r_inner`.
- 4 In the **Height** text field, type `54.95`.
- 5 Locate the **Position** section. In the **x** text field, type `-57`.
- 6 In the **z** text field, type `1.2`.

7 Locate the **Axis** section. From the **Axis type** list, choose **x-axis**.

Add a cylinder for the outer conductor for the coaxial cable.

*Coax outer*

1 In the **Geometry** toolbar, click  **Cylinder**.

2 In the **Settings** window for **Cylinder**, type *Coax outer* in the **Label** text field.

3 Locate the **Size and Shape** section. In the **Radius** text field, type *r\_outer*.

4 In the **Height** text field, type 54.

5 Locate the **Position** section. In the **x** text field, type -57.

6 In the **z** text field, type 1.2.

7 Locate the **Axis** section. From the **Axis type** list, choose **x-axis**.

8 Click  **Build Selected**.

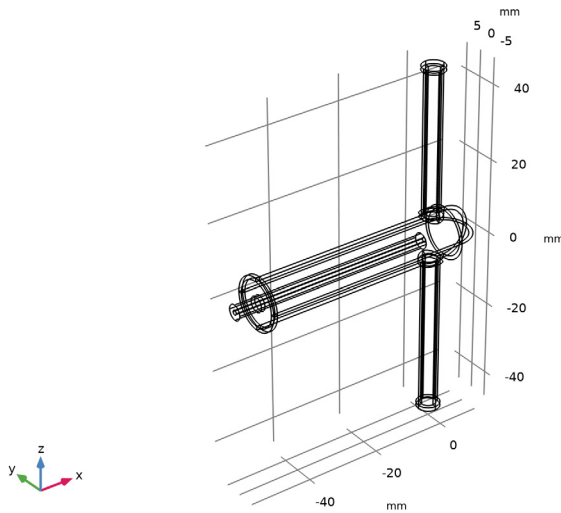

Add a quarter of a torus for the 90-degree bend part connecting the antenna radiator and the inner conductor of the coaxial cable.

*90 degree bend*

1 In the **Geometry** toolbar, click  **Torus**.

2 In the **Settings** window for **Torus**, type 90 degree bend in the **Label** text field.



3 Locate the **Size and Shape** section. In the **Major radius** text field, type *r\_outer*.

4 In the **Minor radius** text field, type *r\_inner*.

- 5 In the **Revolution angle** text field, type 90.
- 6 Locate the **Position** section. In the **x** text field, type `-r_outer`.
- 7 In the **z** text field, type `3.25`.
- 8 Locate the **Axis** section. From the **Axis type** list, choose **y-axis**.
- 9 Locate the **Rotation Angle** section. In the **Rotation** text field, type 270.

Add a cylinder for an antenna radiator.

#### *Radiator*

- 1 In the **Geometry** toolbar, click  **Cylinder**.
- 2 In the **Settings** window for **Cylinder**, type Radiator in the **Label** text field.
- 3 Locate the **Size and Shape** section. In the **Radius** text field, type `r_inner`.
- 4 In the **Height** text field, type `l_wire`.
- 5 Locate the **Position** section. In the **z** text field, type `3.25`.
- 6 Click  **Build Selected**.

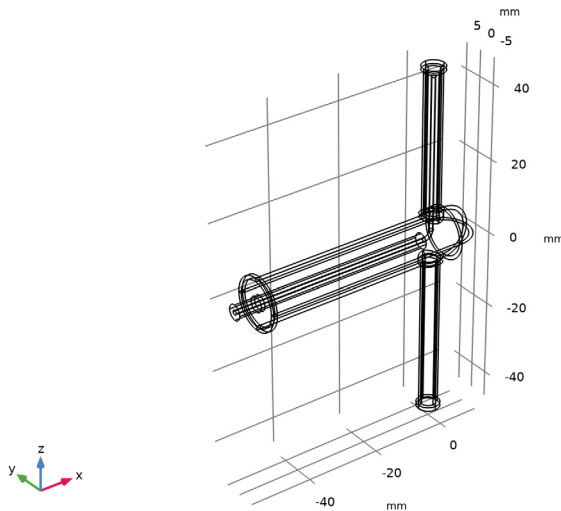

Create a second antenna radiator by mirroring one side.



#### *Mirror 1 (mir1)*

- 1 In the **Geometry** toolbar, click  **Transforms** and choose **Mirror**.
- 2 Select the objects **cy13** and **tor1** only.
- 3 In the **Settings** window for **Mirror**, locate the **Input** section.

4 Select the **Keep input objects** checkbox.

Add a cylinder to connect another 90 degree bend with the outer conductor of the coaxial cable.

*Solder to ground: radiator*

- 1 In the **Geometry** toolbar, click  **Cylinder**.
- 2 In the **Settings** window for **Cylinder**, type Solder to ground: radiator in the **Label** text field.
- 3 Locate the **Size and Shape** section. In the **Radius** text field, type  $r_{inner}$ .
- 4 In the **Height** text field, type 2.95.
- 5 Locate the **Position** section. In the **x** text field, type -5.
- 6 In the **z** text field, type -1.2.
- 7 Locate the **Axis** section. From the **Axis type** list, choose **x-axis**.
- 8 Click  **Build Selected**.

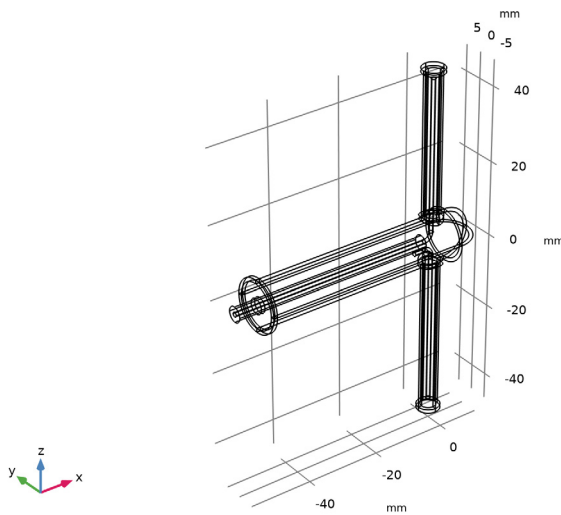

Create the quarter-wave coaxial balun by performing a couple of geometry transform operations.

*Rotate 1 (rot1)*

- 1 In the **Geometry** toolbar, click  **Transforms** and choose **Rotate**.
- 2 Select the objects **mir1(1)** and **mir1(2)** only.

- 3 In the **Settings** window for **Rotate**, locate the **Input** section.
- 4 Select the **Keep input objects** checkbox.
- 5 Locate the **Rotation** section. In the **Angle** text field, type -90.
- 6 From the **Axis type** list, choose **y-axis**.

#### *Move 1 (mov1)*

- 1 In the **Geometry** toolbar, click  **Transforms** and choose **Move**.
- 2 Select the objects **rot1(1)** and **rot1(2)** only.
- 3 In the **Settings** window for **Move**, locate the **Displacement** section.
- 4 In the **x** text field, type -1\_wire-3.25.
- 5 In the **z** text field, type 5.8.

Add a cylinder to connect the balun and the outer conductor of the coaxial cable.

#### *Solder to ground: balun*

- 1 In the **Geometry** toolbar, click  **Cylinder**.
- 2 In the **Settings** window for **Cylinder**, type Solder to ground: balun in the **Label** text field.
- 3 Locate the **Size and Shape** section. In the **Radius** text field, type 1.5.
- 4 In the **Height** text field, type 1.25.
- 5 Locate the **Position** section. In the **x** text field, type -1\_wire-r\_outer.
- 6 In the **z** text field, type 2.5.

Create unions of some of the objects to remove unnecessary edges that would increase the mesh complexity.

#### *Union 1 (uni1)*

- 1 In the **Geometry** toolbar, click  **Booleans and Partitions** and choose **Union**.
- 2 Select the objects **cyl2** and **cyl5** only.
- 3 In the **Settings** window for **Union**, locate the **Union** section.
- 4 Clear the **Keep interior boundaries** checkbox.

#### *Union 2 (uni2)*

- 1 In the **Geometry** toolbar, click  **Booleans and Partitions** and choose **Union**.
- 2 Select the objects **cyl3** and **mov1(1)** only.
- 3 In the **Settings** window for **Union**, locate the **Union** section.
- 4 Clear the **Keep interior boundaries** checkbox.

5 Click  **Build Selected.**

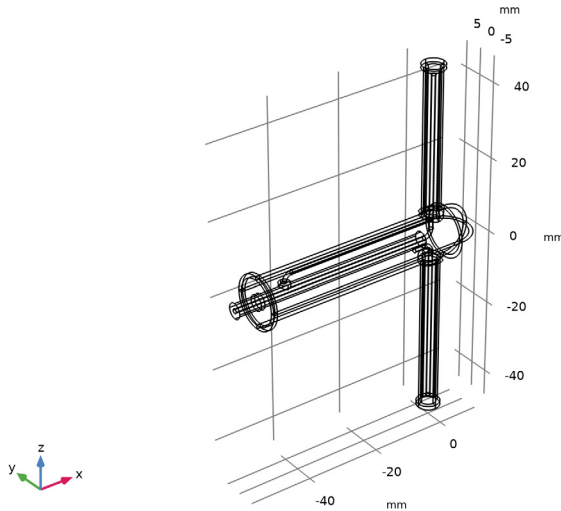

Add a couple of cylinders for the SMA connector.

*SMA*

- 1 In the **Geometry** toolbar, click  **Cylinder**.
- 2 In the **Settings** window for **Cylinder**, type SMA in the **Label** text field.
- 3 Locate the **Size and Shape** section. In the **Radius** text field, type 2.45.
- 4 In the **Height** text field, type 5.
- 5 Locate the **Position** section. In the **x** text field, type -57.
- 6 In the **z** text field, type 1.2.
- 7 Locate the **Axis** section. From the **Axis type** list, choose **x-axis**.

*SMA flange*

- 1 In the **Geometry** toolbar, click  **Cylinder**.
- 2 In the **Settings** window for **Cylinder**, type SMA flange in the **Label** text field.
- 3 Locate the **Size and Shape** section. In the **Radius** text field, type 5.
- 4 Locate the **Position** section. In the **x** text field, type -52.
- 5 In the **z** text field, type 1.2.
- 6 Locate the **Axis** section. From the **Axis type** list, choose **x-axis**.

Add a cylinder on the back side of the coaxial port. This domain is not a part of the model space.

#### *Connector cap*



- 1 In the **Geometry** toolbar, click  **Cylinder**.
- 2 In the **Settings** window for **Cylinder**, type Connector cap in the **Label** text field.
- 3 Locate the **Size and Shape** section. In the **Radius** text field, type  $r_{outer}$ .
- 4 In the **Height** text field, type 2.
- 5 Locate the **Position** section. In the **x** text field, type -59.
- 6 In the **z** text field, type 1.2.
- 7 Locate the **Axis** section. From the **Axis type** list, choose **x-axis**.

Add a cylinder to tune the antenna for generating balanced current distributions on each wire radiator.

#### *Tuning wire*

- 1 In the **Geometry** toolbar, click  **Cylinder**.
- 2 In the **Settings** window for **Cylinder**, type Tuning wire in the **Label** text field.
- 3 Locate the **Size and Shape** section. In the **Radius** text field, type  $r_{inner}$ .
- 4 In the **Height** text field, type  $0.1 * l_{wire}$ .
- 5 Locate the **Position** section. In the **z** text field, type  $-l_{wire} - 3.25$ .

#### *Difference 1 (dif1)*

- 1 In the **Geometry** toolbar, click  **Booleans and Partitions** and choose **Difference**.
- 2 Select the object **mir1(1)** only.
- 3 In the **Settings** window for **Difference**, locate the **Difference** section.
- 4 Click to select the  **Activate Selection** toggle button for **Objects to subtract**.
- 5 Select the object **cyl9** only.

6 Click  **Build Selected.**

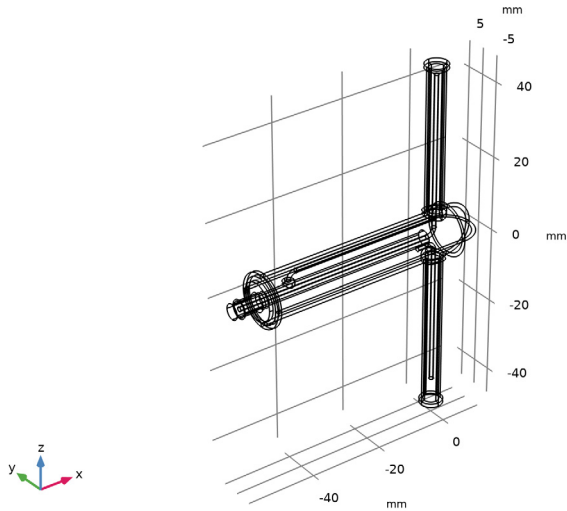

Add a sphere for the PML.

*PML*

- 1 In the **Geometry** toolbar, click  **Sphere.**
- 2 In the **Settings** window for **Sphere**, type PML in the **Label** text field.
- 3 Locate the **Size** section. In the **Radius** text field, type 100.
- 4 Click to expand the **Layers** section. In the table, enter the following settings:

Layer name	Thickness (mm)
Layer 1	30

5 Click  **Build All Objects.**

6 Click the  **Zoom Extends** button in the **Graphics** toolbar.

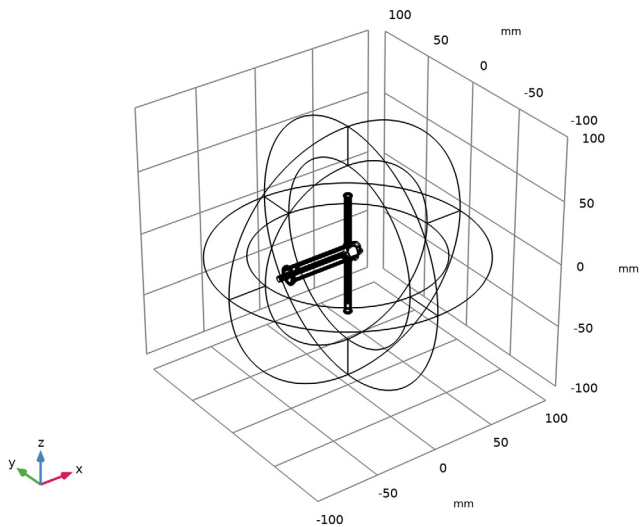



7 Click the  **Zoom In** button in the **Graphics** toolbar twice.

### DEFINITIONS

Create a set of selections for use before setting up the physics. First, create selections for the conductor boundaries.

#### *Coax outer boundaries*

- 1 In the **Definitions** toolbar, click  **Explicit**.
- 2 In the **Settings** window for **Explicit**, type `Coax outer boundaries` in the **Label** text field.
- 3 Locate the **Input Entities** section. From the **Geometric entity level** list, choose **Boundary**.
- 4 Click  **Paste Selection**.
- 5 In the **Paste Selection** dialog, type `59-60, 68, 71, 85-86, 91-92, 98-100, 104, 107` in the **Selection** text field.

6 Click **OK**.

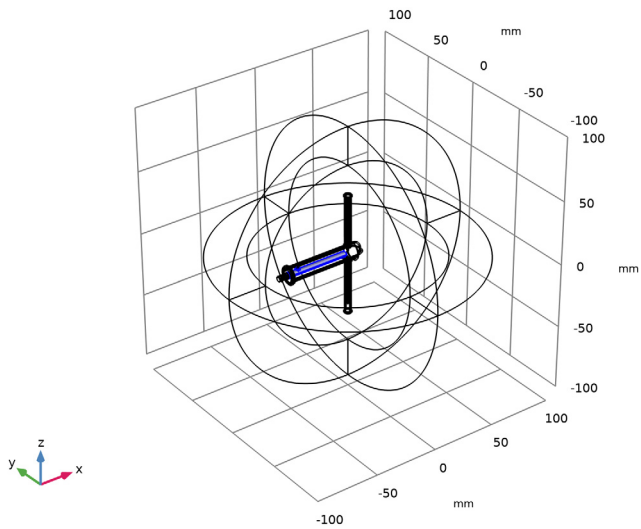

Add a selection for the dielectric material inside the coaxial cable.

*Coax dielectric*

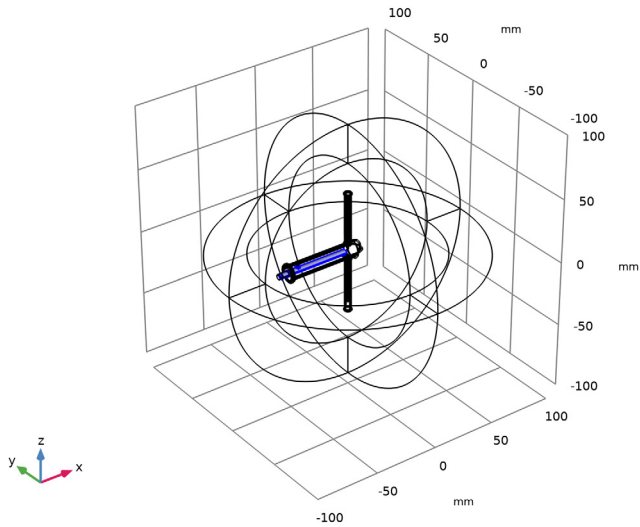

- 1 In the **Definitions** toolbar, click  **Explicit**.
- 2 In the **Settings** window for **Explicit**, type `Coax dielectric` in the **Label** text field.

3 Select Domains 8, 11, 16, and 28 only.





Add a selection for the antenna enclosure.

#### *Enclosure*

- 1 In the **Definitions** toolbar, click  **Explicit**.
- 2 In the **Settings** window for **Explicit**, type Enclosure in the **Label** text field.
- 3 Locate the **Input Entities** section. Click  **Paste Selection**.
- 4 In the **Paste Selection** dialog, type 13-15, 18-21, 23-24, 30-39, 45-48, 51-58 in the **Selection** text field.

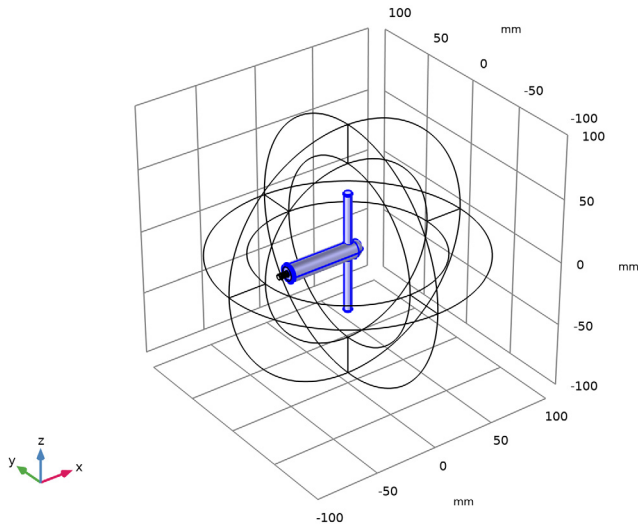
5 Click **OK**.



6 Click the  **Zoom Extents** button in the **Graphics** toolbar.

7 Click the  **Zoom In** button in the **Graphics** toolbar.

Add a selection for the connector cap.

*Coax cap*

1 In the **Definitions** toolbar, click  **Explicit**.

2 In the **Settings** window for **Explicit**, type **Coax cap** in the **Label** text field.

3 Select Domain 6 only.

Add a selection for the model domain. Use the complement of the connector cap selection.

*Model domain*

1 In the **Definitions** toolbar, click  **Complement**.

2 In the **Settings** window for **Complement**, type **Model domain** in the **Label** text field.

3 Locate the **Input Entities** section. Under **Selections to invert**, click  **Add**.

4 In the **Add** dialog, select **Coax cap** in the **Selections to invert** list.

5 Click **OK**.

*Perfectly Matched Layer 1 (pml1)*

1 In the **Definitions** toolbar, click  **Perfectly Matched Layer**.

2 Select Domains 1–4, 43, 44, 49, and 50 only.

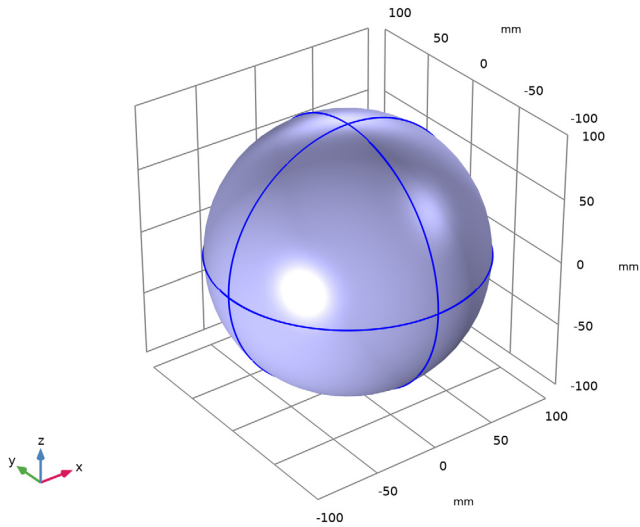

3 In the **Settings** window for **Perfectly Matched Layer**, locate the **Geometry** section.

4 From the **Type** list, choose **Spherical**.

*Hide for Physics I*

1 In the **Model Builder** window, right-click **View 1** and choose **Hide for Physics**.

2 Select Domains 1, 2, 43, and 44 only.

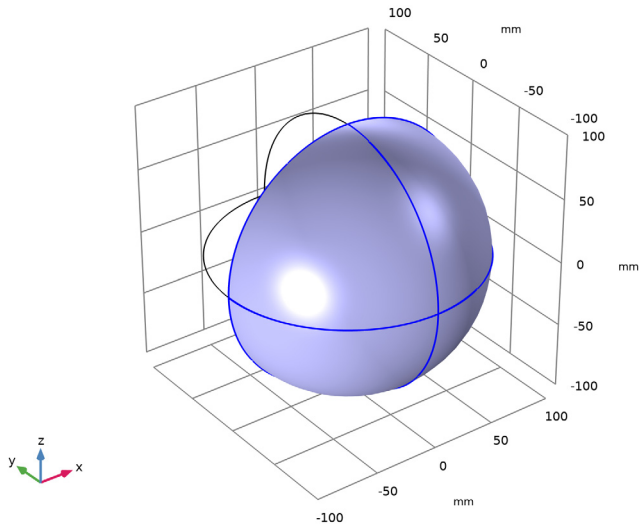

*Hide for Physics 2*

- 1 Right-click **View 1** and choose **Hide for Physics**.
- 2 In the **Settings** window for **Hide for Physics**, locate the **Geometric Entity Selection** section.
- 3 From the **Geometric entity level** list, choose **Boundary**.

4 Select Boundaries 9, 10, 195, and 196 only.

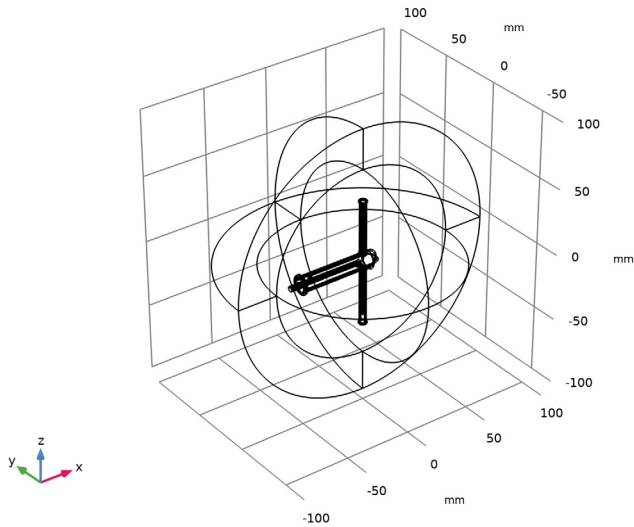



### **ELECTROMAGNETIC WAVES, FREQUENCY DOMAIN (EMW)**

Now, set up the physics. Choose an appropriate selection when you assign each boundary condition.

- 1 In the **Model Builder** window, under **Component 1 (comp1)** click **Electromagnetic Waves, Frequency Domain (emw)**.
- 2 In the **Settings** window for **Electromagnetic Waves, Frequency Domain**, locate the **Domain Selection** section.
- 3 From the **Selection** list, choose **Model domain**.
- 4 Click the  **Zoom In** button in the **Graphics** toolbar.

#### *Perfect Electric Conductor 2*

- 1 In the **Physics** toolbar, click  **Domains** and choose **Perfect Electric Conductor**.
- 2 In the **Settings** window for **Perfect Electric Conductor**, locate the **Domain Selection** section.
- 3 Click  **Paste Selection**.
- 4 In the **Paste Selection** dialog, type 9, 12, 17, 25-27, 29, 40-42 in the **Selection** text field.

5 Click **OK**.

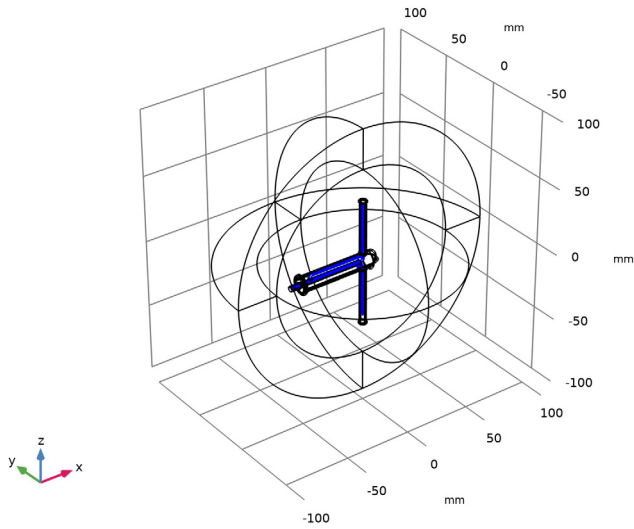

#### *Perfect Electric Conductor 3*

- 1 In the **Physics** toolbar, click  **Boundaries** and choose **Perfect Electric Conductor**.
- 2 In the **Settings** window for **Perfect Electric Conductor**, locate the **Boundary Selection** section.
- 3 From the **Selection** list, choose **Coax outer boundaries**.

#### *Perfect Electric Conductor 4*

- 1 In the **Physics** toolbar, click  **Domains** and choose **Perfect Electric Conductor**.

2 Select Domains 7 and 10 only.

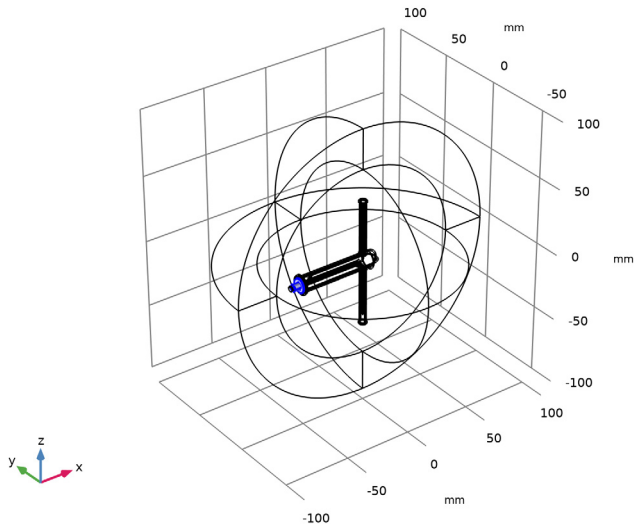

#### *Lumped Port 1*

- 1 In the **Physics** toolbar, click  **Boundaries** and choose **Lumped Port**.
- 2 Select Boundary 21 only.
- 3 In the **Settings** window for **Lumped Port**, locate the **Lumped Port Properties** section.
- 4 From the **Type of lumped port** list, choose **Coaxial**.  
For the first port, wave excitation is **on** by default.



#### *Far-Field Domain 1*

In the **Physics** toolbar, click  **Domains** and choose **Far-Field Domain**.

### **MATERIALS**

Assign material properties. Use air for all domains, first.

#### **ADD MATERIAL**

- 1 In the **Materials** toolbar, click  **Add Material** to open the **Add Material** window.
- 2 Go to the **Add Material** window.
- 3 In the tree, select **Built-in > Air**.
- 4 Click the **Add to Component** button in the window toolbar.
- 5 In the **Materials** toolbar, click  **Add Material** to close the **Add Material** window.

## MATERIALS

Override the coax dielectric domains with a dielectric material of  $\epsilon_r = 2.1$ .

### PTFE

- 1 In the **Model Builder** window, under **Component 1 (comp1)** right-click **Materials** and choose **Blank Material**.
- 2 In the **Settings** window for **Material**, type PTFE in the **Label** text field.
- 3 Locate the **Geometric Entity Selection** section. From the **Selection** list, choose **Coax dielectric**.
- 4 Locate the **Material Contents** section. In the table, enter the following settings:

Property	Variable	Value	Unit	Property group
Relative permittivity	epsilon <sub>nr_</sub> iso ; epsilon <sub>nr_</sub> ii = epsilon <sub>nr_</sub> iso, epsilon <sub>nr_</sub> ij = 0	2.1		Basic
Relative permeability	mu <sub>r_</sub> iso ; mu <sub>r_</sub> ii = mu <sub>r_</sub> iso, mu <sub>r_</sub> ij = 0	1		Basic
Electric conductivity	sigma <sub>iso</sub> ; sigma <sub>ii</sub> = sigma <sub>iso</sub> , sigma <sub>ij</sub> = 0	0	S/m	Basic

Override the antenna enclosure with a dielectric material of  $\epsilon_r = 2.4$ .

### ABS

- 1 Right-click **Materials** and choose **Blank Material**.
- 2 In the **Settings** window for **Material**, type ABS in the **Label** text field.
- 3 Locate the **Geometric Entity Selection** section. From the **Selection** list, choose **Enclosure**.

4 Locate the **Material Contents** section. In the table, enter the following settings:

Property	Variable	Value	Unit	Property group
Relative permittivity	epsilon <sub>nr_</sub> iso ; epsilon <sub>nrii</sub> = epsilon <sub>nr_</sub> iso, epsilon <sub>nrij</sub> = 0	2.4		Basic
Relative permeability	mu <sub>r_</sub> iso ; mu <sub>rii</sub> = mu <sub>r_</sub> iso, mu <sub>rij</sub> = 0	1		Basic
Electric conductivity	sigma <sub>iso</sub> ; sigma <sub>ii</sub> = sigma <sub>iso</sub> , sigma <sub>ij</sub> = 0	0	S/m	Basic

#### MESH 1

- 1 In the **Model Builder** window, under **Component 1 (comp1)** click **Mesh 1**.
- 2 In the **Settings** window for **Mesh**, locate the **Physics-Controlled Mesh** section.
- 3 In the table, clear the **Use** checkbox for **Geometric Analysis, Detail Size**.
- 4 Click  **Build All**.

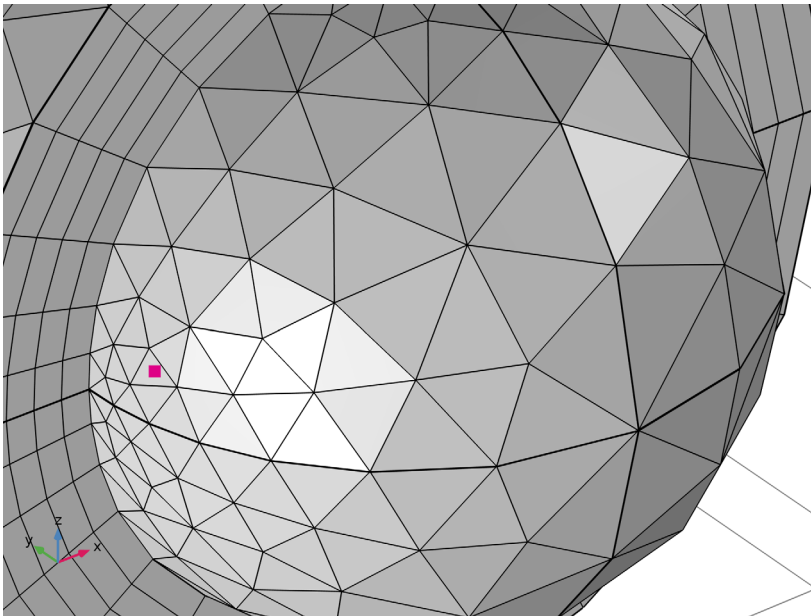

## STUDY 1

In the **Study** toolbar, click  **Compute**.



## RESULTS

The default plot shows the E-field norm, 2D far-field polar plot, and 3D far-field radiation pattern. Switch the parameter value to the center frequency in the sweep to plot the results on the resonant frequency.

### *Electric Field (emw)*

- 1 In the **Model Builder** window, under **Results** click **Electric Field (emw)**.
- 2 In the **Settings** window for **3D Plot Group**, locate the **Data** section.
- 3 From the **Parameter value (freq (GHz))** list, choose **1.575**.

### *Multislice*

- 1 In the **Model Builder** window, expand the **Electric Field (emw)** node, then click **Multislice**.
- 2 In the **Settings** window for **Multislice**, locate the **Multipane Data** section.
- 3 Find the **X-planes** subsection. In the **Planes** text field, type 0.
- 4 Find the **Z-planes** subsection. In the **Planes** text field, type 0.
- 5 Find the **Y-planes** subsection. From the **Entry method** list, choose **Coordinates**.
- 6 In the **Coordinates** text field, type 0.
- 7 In the **Graphics** window toolbar, click  next to  **Go to Default View**, then choose **Go to ZX View**.
- 8 Click the  **Zoom In** button in the **Graphics** toolbar.
- 9 Click to expand the **Range** section. Select the **Manual color range** checkbox.
- 10 In the **Maximum** text field, type 1000.

II In the **Electric Field (emw)** toolbar, click  **Plot**.

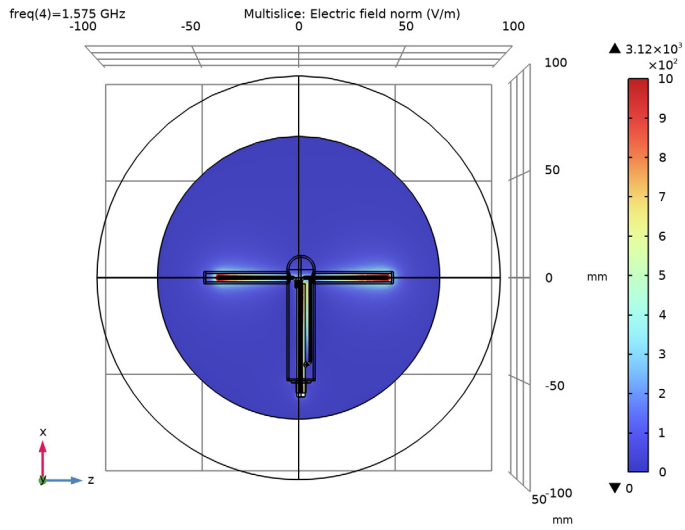

The plot shows the symmetric E-field norm distribution on the wires; compare with [Figure 3](#).

S-parameter (emw)

I In the **Model Builder** window, under **Results** click **S-parameter (emw)**.

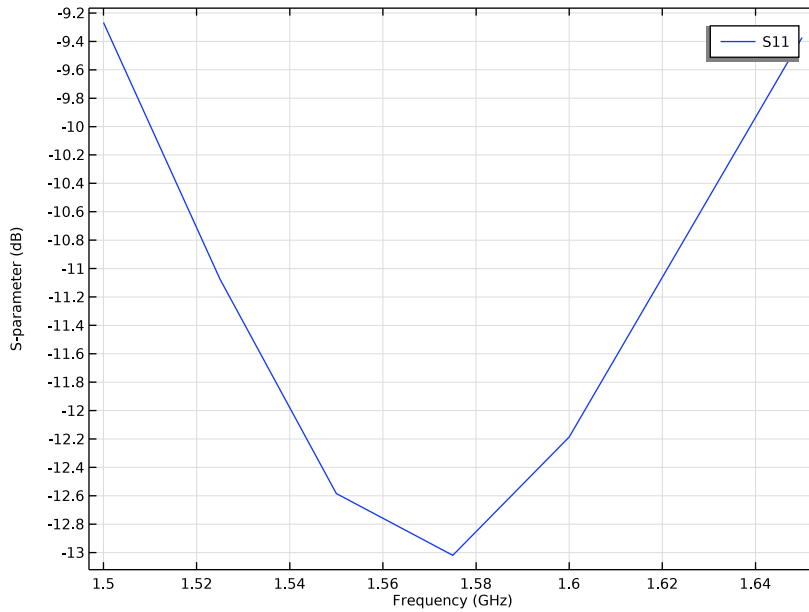

Compare the result with the S-parameter plot in [Figure 6](#).

*Smith Plot (emw)*

In the **Model Builder** window, click **Smith Plot (emw)**.

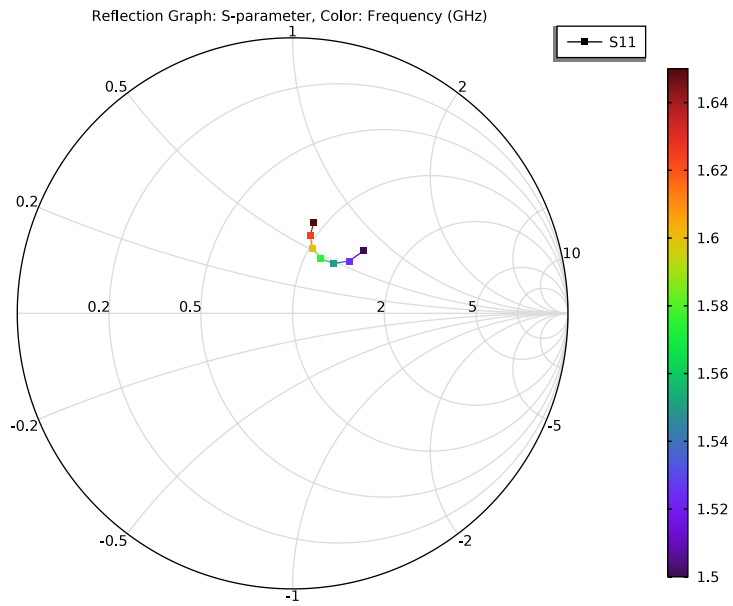

### Electric Field, Logarithmic (emw)

In the **Model Builder** window, click **Electric Field, Logarithmic (emw)**.

freq(7)=1.65 GHz Surface: 1 (1) Surface: 1 (1) Surface: 1 (1) Multislice: Electric field norm (V/m) Surface: Electric field norm (V/m) Surface: Electric field norm (V/m)

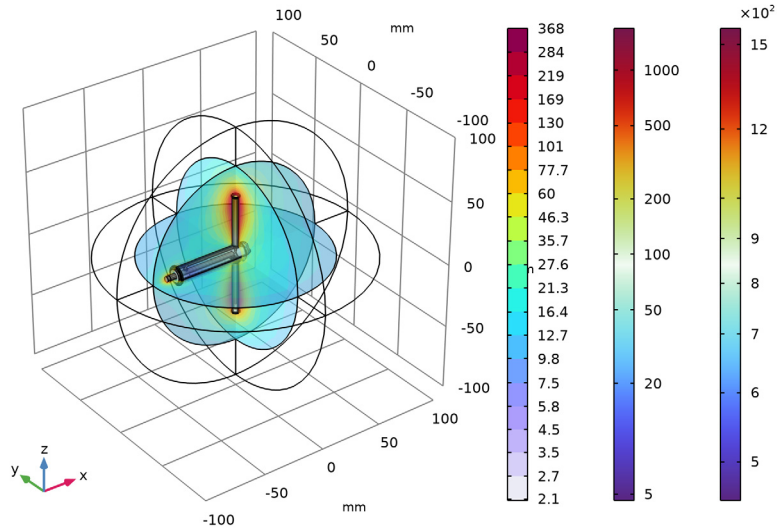

### 2D Far Field (emw)

Adjust the axis range.

- 1 In the **Model Builder** window, click **2D Far Field (emw)**.
- 2 In the **Settings** window for **Polar Plot Group**, locate the **Axis** section.
- 3 Select the **Manual axis limits** checkbox.
- 4 In the **r minimum** text field, type 0.

5 In the **2D Far Field (emw)** toolbar, click  **Plot**.

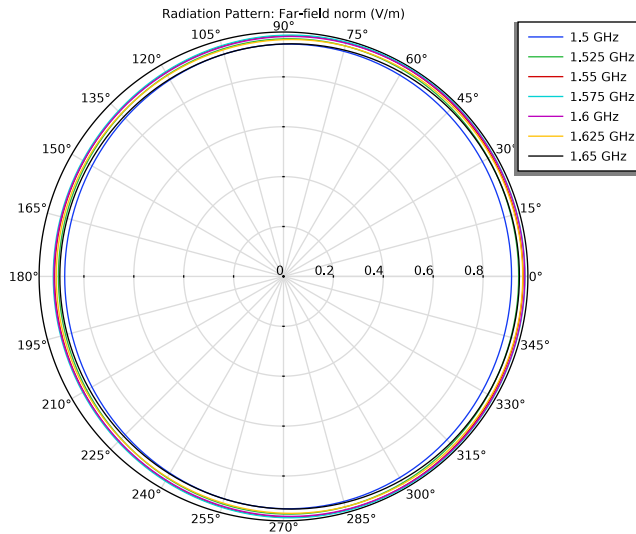

The plotted H-plane patterns are almost isotropic as shown in [Figure 4](#).

### 3D Far Field, Gain (emw)

- 1 In the **Model Builder** window, click **3D Far Field, Gain (emw)**.
- 2 In the **Settings** window for **3D Plot Group**, locate the **Data** section.
- 3 From the **Parameter value (freq (GHz))** list, choose **1.575**.

### Radiation Pattern I

I In the **Model Builder** window, expand the **3D Far Field, Gain (emw)** node, then click **Radiation Pattern I**.

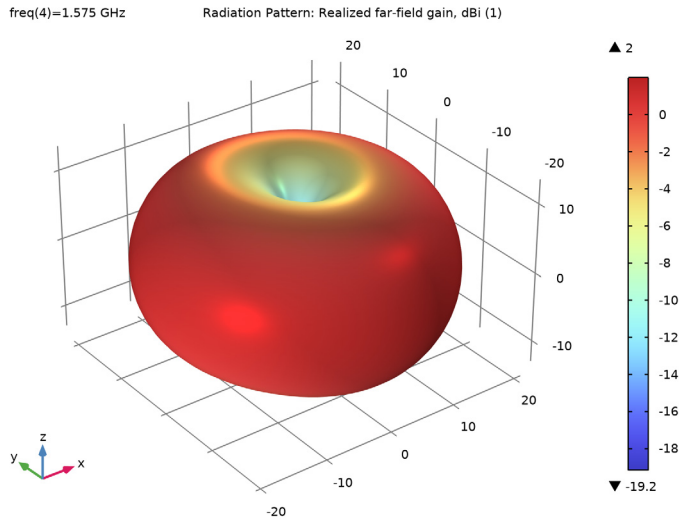

The visualized 3D radiation pattern looks like the radiation pattern of a typical dipole antenna. Compare the reproduced plot with [Figure 5](#).

