



# Bracket — Stress Optimization with Fatigue Evaluation

## Introduction

---

This model demonstrates how to improve fatigue properties using shape optimization. The fatigue properties are not optimized directly. Instead a heuristic methodology is applied where an approximate value of the maximum stress is minimized subject to constraints on the mass and stiffness.

## Model Definition

---

The model is based on the model *Bracket — Fatigue Evaluation* in the Fatigue Module Application Library. The initial stiffness as well as fatigue properties can thus be evaluated immediately. The fatigue analysis indicates that failure is likely to occur near some small fillets as illustrated in [Figure 1](#).

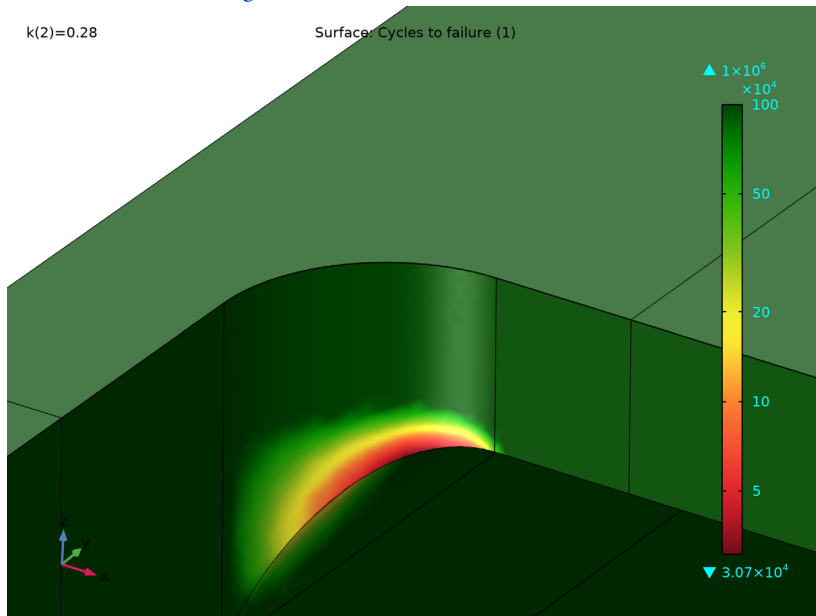

*Figure 1: The initial fatigue properties.*

The **Free Shape Domain**, **Free Shape Boundary**, and **Symmetry/Roller** shape optimization features are used to allow modification of the fillet details, where the maximum stress occurs. COMSOL does not support optimization of the fatigue properties directly, so a heuristic approach is applied. The method is not guaranteed to improve the fatigue properties and therefore it is critical that these are evaluated before and after optimization.

The heuristic approach involves using the  $p$ -norm of the von Mises stress as the objective function,  $\varphi$ ,

$$\varphi = \left[ \int_{\Omega} (\sigma_{\text{mises}} / \sigma_{\text{max}})^p d\Omega / \int_{\Omega} d\Omega \right]^{1/p}$$

For large values of  $p$  the objective is a good approximation of the maximum stress, but too large values can cause numerical problems for the optimization solver, so the model uses  $p = 50$ . The objective is scaled with the initial value, so (strictly speaking) the maximum stress,  $\sigma_{\text{max}}$ , does not play a role; it only serves to prevent unit warnings. COMSOL Multiphysics comes with built-in variables for the volume and the stiffness, so it is easy to specify these constraints. The number of optimization iterations is limited to 20 and an iterative solver is used for the structural mechanics to save computation time.

### *Results and Discussion*

As one might expect the optimization increases the fillet to reduce the maximum stress. This can be seen in [Figure 2](#).

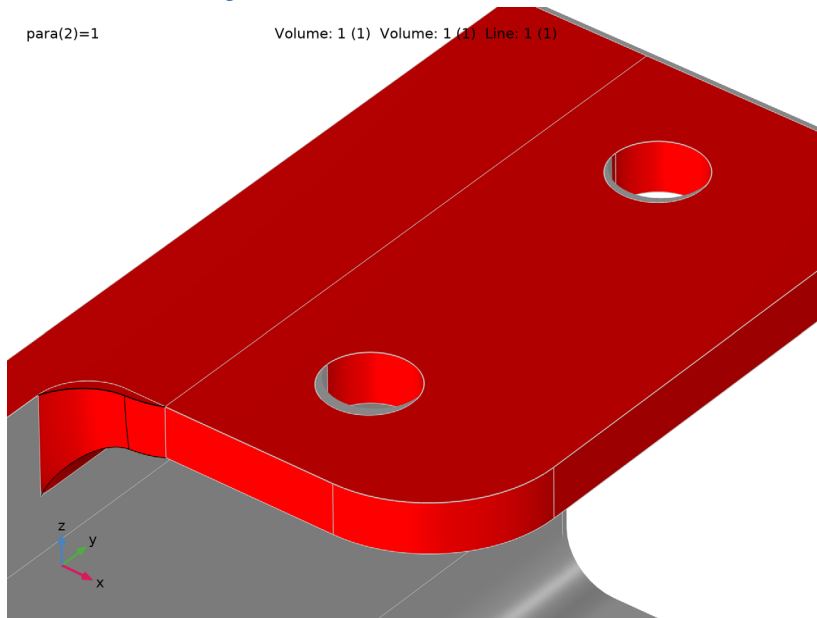

*Figure 2: The shape optimization increases the fillet radius at the point of maximum stress.*

To verify that the optimization has indeed improved the fatigue properties, a fatigue analysis is performed on the optimized design, and the result can be seen in [Figure 3](#).

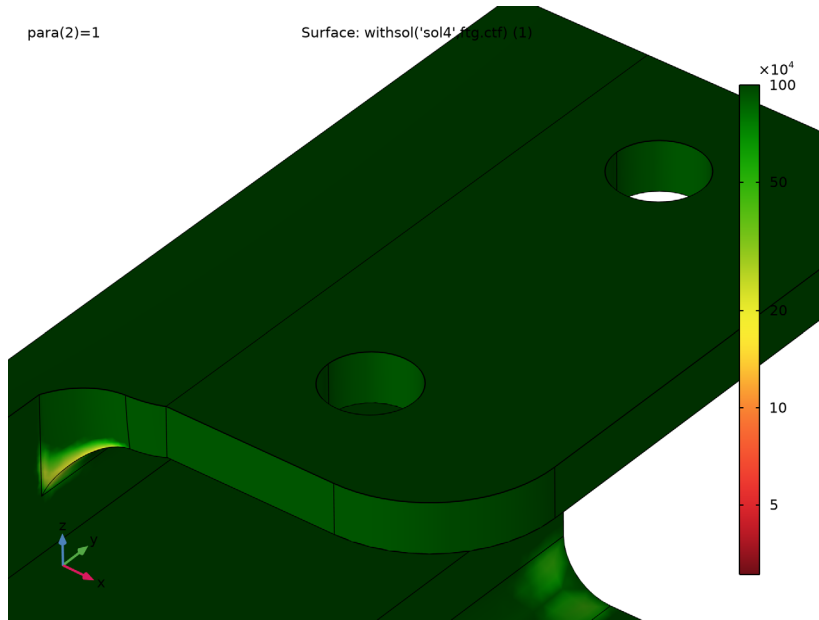

*Figure 3: The shape optimization has removed the stress concentration at the fillet as compared to the initial design in [Figure 2](#).*

### *Notes About the COMSOL Implementation*

The MMA optimization solver is used, but note that the (default) globally convergent behavior is disabled. The **Fatigue** study step zeros the shape optimization variables, so the model uses the `withsol` operator to plot the fatigue usage in the deformed frame.

**Application Library path:** Optimization\_Module/Shape\_Optimization/  
bracket\_fatigue\_optimization

## ROOT

In this example you will start from an existing model from the Fatigue Module.

## APPLICATION LIBRARIES

- 1 From the **File** menu, choose **Application Libraries**.
- 2 In the **Application Libraries** window, select **Fatigue Module > Stress Life > bracket\_fatigue** in the tree.
- 3 Click  **Open**.

Start by computing the stiffness of the initial design in a new **Evaluation Group**.

## RESULTS

### *Initial Compliance*

- 1 In the **Results** toolbar, click  **Evaluation Group**.
- 2 In the **Settings** window for **Evaluation Group**, type Initial Compliance in the **Label** text field.
- 3 Locate the **Data** section. From the **Parameter selection (para)** list, choose **Last**.

### *Global Evaluation 1*

- 1 Right-click **Initial Compliance** and choose **Global Evaluation**.
- 2 In the **Settings** window for **Global Evaluation**, click **Add Expression** in the upper-right corner of the **Expressions** section. From the menu, choose **Component 1 (comp1) > Solid Mechanics > Global > solid.Ws\_tot - Total elastic strain energy - J**.
- 3 In the **Initial Compliance** toolbar, click  **Evaluate**.

## GLOBAL DEFINITIONS

### *Parameters 1*

- 1 In the **Model Builder** window, under **Global Definitions** click **Parameters 1**.
- 2 In the **Settings** window for **Parameters**, locate the **Parameters** section.
- 3 In the table, enter the following settings:

Name	Expression	Value	Description
pExp	50	50	P-norm exponent

Name	Expression	Value	Description
sigmaMax	100[MPa]	1E8 Pa	Maximum stress
Ws0	0.69[J]	0.69 J	Characteristic stiffness

### COMPONENT I (COMP I)

In the **Model Builder** window, expand the **Component I (comp I)** node.



### DEFINITIONS

In the **Model Builder** window, expand the **Component I (comp I) > Definitions** node.

#### *Free Boundaries*

- 1 In the **Model Builder** window, expand the **Component I (comp I) > Definitions > Selections** node.
- 2 Right-click **Definitions** and choose **Selections > Explicit**.
- 3 In the **Settings** window for **Explicit**, type **Free Boundaries** in the **Label** text field.
- 4 Locate the **Input Entities** section. From the **Geometric entity level** list, choose **Boundary**.
- 5 Click  **Paste Selection**.
- 6 In the **Paste Selection** dialog, type 24, 25, 28, 29 in the **Selection** text field.
- 7 Click **OK**.

#### *Symmetry Boundaries*



- 1 Right-click **Free Boundaries** and choose **Duplicate**.
- 2 In the **Settings** window for **Explicit**, type **Symmetry Boundaries** in the **Label** text field.
- 3 Locate the **Input Entities** section. Click  **Clear Selection**.
- 4 Click  **Paste Selection**.
- 5 In the **Paste Selection** dialog, type 15, 65 in the **Selection** text field.
- 6 Click **OK**.

#### *Free Domains*

- 1 In the **Definitions** toolbar, click  **Adjacent**.
- 2 In the **Settings** window for **Adjacent**, type **Free Domains** in the **Label** text field.
- 3 Locate the **Input Entities** section. From the **Geometric entity level** list, choose **Boundary**.
- 4 Locate the **Output Entities** section. From the **Geometric entity level** list, choose **Adjacent domains**.
- 5 Locate the **Input Entities** section. Under **Input selections**, click **+ Add**.
- 6 In the **Add** dialog, select **Free Boundaries** in the **Input selections** list.

7 Click **OK**.

### *Symmetry Domains*

- 1 In the **Definitions** toolbar, click  **Explicit**.
- 2 In the **Settings** window for **Explicit**, type Symmetry Domains in the **Label** text field.
- 3 Locate the **Input Entities** section. Click  **Paste Selection**.
- 4 In the **Paste Selection** dialog, type 8 in the **Selection** text field.
- 5 Click **OK**.

### *Average 1 (aveop1)*

- 1 In the **Definitions** toolbar, click  **Nonlocal Couplings** and choose **Average**.
- 2 In the **Settings** window for **Average**, locate the **Source Selection** section.
- 3 From the **Selection** list, choose **Free Domains**.

### *Objective Function*

- 1 In the **Model Builder** window, right-click **Definitions** and choose **Variables**.
- 2 In the **Settings** window for **Variables**, type Objective Function in the **Label** text field.
- 3 Locate the **Variables** section. In the table, enter the following settings:

Name	Expression	Unit	Description
obj	aveop1((solid.mises/sigmaMax)^pExp)^(1/pExp)		Objective function

## **COMPONENT 1 (COMP1)**

### *Free Shape Domain 1*

- 1 In the **Physics** toolbar, click  **Optimization** and choose **Shape Optimization**.
- 2 In the **Settings** window for **Free Shape Domain**, locate the **Domain Selection** section.
- 3 From the **Selection** list, choose **Free Domains**.

### *Free Shape Boundary 1*

- 1 In the **Shape Optimization** toolbar, click  **Free Shape Boundary**.
- 2 In the **Settings** window for **Free Shape Boundary**, locate the **Boundary Selection** section.
- 3 From the **Selection** list, choose **Free Boundaries**.

The bracket thickness is 8 mm, so we set a maximum displacement that is smaller to avoid inverted elements.

- 4 Locate the **Control Variable Settings** section. In the text field, type 3[mm], which corresponds to twice the maximum displacement.

### *Symmetry/Roller 1*

- 1 In the **Shape Optimization** toolbar, click  **Symmetry/Roller**.
- 2 In the **Settings** window for **Symmetry/Roller**, locate the **Geometric Entity Selection** section.
- 3 From the **Selection** list, choose **Symmetry Boundaries**.

### *Mirror Symmetry 1*

- 1 In the **Shape Optimization** toolbar, click  **Mirror Symmetry**.
- 2 In the **Settings** window for **Mirror Symmetry**, locate the **Geometric Entity Selection** section.
- 3 From the **Selection** list, choose **Symmetry Domains**.
- 4 Locate the **Plane** section. From the **p** list, choose **User defined**.
- 5 From the **n** list, choose **User defined**.

### **ADD STUDY**

- 1 In the **Home** toolbar, click  **Add Study** to open the **Add Study** window.
- 2 Go to the **Add Study** window.
- 3 Find the **Studies** subsection. In the **Select Study** tree, select **Empty Study**.
- 4 Click the **Add Study** button in the window toolbar twice.

### **STUDY 1: INITIAL DESIGN**

In the **Settings** window for **Study**, type Study 1: Initial Design in the **Label** text field.

### *Step 1: Stationary*

- 1 In the **Model Builder** window, expand the **Study 1: Initial Design** node.
- 2 Right-click **Study 1: Initial Design > Step 1: Stationary** and choose **Copy**.

### **STUDY 3: OPTIMIZED DESIGN**

- 1 In the **Model Builder** window, click **Study 3**.
- 2 In the **Settings** window for **Study**, type Study 3: Optimized Design in the **Label** text field.
- 3 Right-click **Study 3: Optimized Design** and choose **Paste Stationary**.

### *Shape Optimization*

- 1 In the **Study** toolbar, click  **Optimization** and choose **Shape Optimization**.
- 2 In the **Settings** window for **Shape Optimization**, locate the **Optimization Solver** section.
- 3 In the **Maximum number of iterations** text field, type 15.

- 4 In the **Move limits** text field, type 0.2.
- 5 Click **Add Expression** in the upper-right corner of the **Objective Function** section. From the menu, choose **Component 1 (comp1) > Definitions > Variables > comp1.obj - Objective function - I**.

Use an if-statement to evaluate the objective for the last solution.

- 6 Locate the **Objective Function** section. In the table, enter the following settings:

Expression	Description
if(para==1, comp1.obj, 0)	Objective Function

- 7 From the **Objective scaling** list, choose **Initial solution based**.
- 8 Click **Add Expression** in the upper-right corner of the **Constraints** section. From the menu, choose **Component 1 (comp1) > Definitions > Free Shape Domain 1 > comp1.fsd1.relVolume - Material volume divided by geometry volume - I**.
- 9 Click **Add Expression** in the upper-right corner of the **Constraints** section. From the menu, choose **Component 1 (comp1) > Solid Mechanics > Global > comp1.solid.Ws\_tot - Total elastic strain energy - J**.
- 10 Locate the **Constraints** section. In the table, enter the following settings:

Expression	Lower bound	Upper bound
comp1.fsd1.relVolume		1
comp1.solid.Ws_tot/Ws0		1

This prevents the optimized design from being heavier or less stiff.

- 11 In the **Study** toolbar, click  **Get Initial Value**.

## RESULTS

*Stress (solid) I*

Right-click **Results > Stress (solid) I** and choose **Delete**.

## STUDY 3: OPTIMIZED DESIGN

*Solver Configurations*

In the **Model Builder** window, expand the **Study 3: Optimized Design > Solver Configurations** node.

### *Solution 3 (sol3)*

- 1 In the **Model Builder** window, expand the **Study 3: Optimized Design** > **Solver Configurations** > **Solution 3 (sol3)** node, then click **Optimization Solver I**.
- 2 In the **Settings** window for **Optimization Solver**, locate the **Optimization Solver** section.
- 3 Clear the **Globally Convergent MMA** checkbox to save computational time.
- 4 In the **Model Builder** window, expand the **Study 3: Optimized Design** > **Solver Configurations** > **Solution 3 (sol3)** > **Optimization Solver I** > **Stationary Solver I** > **Segregated I** node, then click **Solid Mechanics**.
- 5 In the **Settings** window for **Segregated Step**, locate the **General** section.
- 6 From the **Linear solver** list, choose **Suggested Iterative Solver (solid)** to reduce the computational time further.

### *Shape Optimization*

- 1 In the **Model Builder** window, under **Study 3: Optimized Design** click **Shape Optimization**.
- 2 In the **Settings** window for **Shape Optimization**, locate the **Output While Solving** section.
- 3 Select the **Plot** checkbox.
- 4 From the **Plot group** list, choose **Shape Optimization**.
- 5 In the **Study** toolbar, click  **Compute**.

### **STUDY 2: INITIAL FATIGUE**

- 1 In the **Model Builder** window, click **Study 2**.
- 2 In the **Settings** window for **Study**, type Study 2: Initial Fatigue in the **Label** text field.
- 3 In the **Model Builder** window, expand the **Study 2: Initial Fatigue** node.

### *Parametric Sweep, Step 1: Fatigue*

- 1 In the **Model Builder** window, under **Study 2: Initial Fatigue**, Ctrl-click to select **Parametric Sweep** and **Step 1: Fatigue**.
- 2 Right-click and choose **Copy**.

### **STUDY 4: OPTIMIZED FATIGUE**

- 1 In the **Model Builder** window, click **Study 4**.
- 2 In the **Settings** window for **Study**, type Study 4: Optimized Fatigue in the **Label** text field.
- 3 Right-click **Study 4: Optimized Fatigue** and choose **Paste Multiple Items**.

### *Step 1: Fatigue*

- 1 In the **Settings** window for **Fatigue**, locate the **Values of Dependent Variables** section.
- 2 Find the **Values of variables not solved for** subsection. From the **Study** list, choose **Study 3: Optimized Design, Stationary**.
- 3 In the **Study** toolbar, click  **Compute**.

## **RESULTS**

### *Shape Optimization 1*

In the **Model Builder** window, under **Results** right-click **Shape Optimization 1** and choose **Delete**.

### *Cycles to Failure, Optimized*

- 1 In the **Model Builder** window, under **Results** click **Cycles to Failure (ftg) 1**.
- 2 In the **Settings** window for **3D Plot Group**, type Cycles to Failure, Optimized in the **Label** text field.

The **Fatigue** study step returns zero for the dependent variables not solved for, so plotting the fatigue usage in the deformed configuration requires the use of the `withsol` operator.

- 3 Locate the **Data** section. From the **Dataset** list, choose **Study 3: Optimized Design/ Solution 3 (sol3)**.

### *Surface 1*

- 1 In the **Model Builder** window, expand the **Cycles to Failure, Optimized** node, then click **Surface 1**.
- 2 In the **Settings** window for **Surface**, locate the **Expression** section.
- 3 In the **Expression** text field, type `withsol('sol14',ftg.ctf)`.

Create an **Evaluation Group** to compare the fatigue properties before and after the optimization.

### *Fatigue Comparison*

- 1 In the **Results** toolbar, click  **Evaluation Group**.
- 2 In the **Settings** window for **Evaluation Group**, type Fatigue Comparison in the **Label** text field.
- 3 Locate the **Data** section. From the **Dataset** list, choose **Study 2: Initial Fatigue/ Solution 2 (sol2)**.

### *Surface Minimum 1*

- 1 Right-click **Fatigue Comparison** and choose **Minimum > Surface Minimum**.
- 2 In the **Settings** window for **Surface Minimum**, locate the **Selection** section.
- 3 From the **Selection** list, choose **Free Boundaries**.
- 4 Click **Add Expression** in the upper-right corner of the **Expressions** section. From the menu, choose **Component 1 (comp1) > Fatigue > ftg.ctf - Cycles to failure - 1**.

### *Surface Minimum 2*

- 1 Right-click **Surface Minimum 1** and choose **Duplicate**.
- 2 In the **Settings** window for **Surface Minimum**, locate the **Data** section.
- 3 From the **Dataset** list, choose **Study 4: Optimized Fatigue/Solution 4 (sol4)**.
- 4 In the **Fatigue Comparison** toolbar, click  **Evaluate**.

The fatigue life has been improved by an order of magnitude.

## **FATIGUE COMPARISON**

Go to the **Fatigue Comparison** window.

Create a plot for visualizing the shape change using a volumetric representation.

## **RESULTS**

### *Shape Optimization, Volumetric*

- 1 In the **Results** toolbar, click  **3D Plot Group**.
- 2 In the **Settings** window for **3D Plot Group**, type Shape Optimization, Volumetric in the **Label** text field.
- 3 Locate the **Data** section. From the **Dataset** list, choose **Study 3: Optimized Design/Solution 3 (sol3)**.

### *Volume 1*

- 1 Right-click **Shape Optimization, Volumetric** and choose **Volume**.
- 2 In the **Settings** window for **Volume**, locate the **Expression** section.
- 3 In the **Expression** text field, type 1.
- 4 Locate the **Coloring and Style** section. From the **Coloring** list, choose **Uniform**.

### *Volume 2*

- 1 Right-click **Volume 1** and choose **Duplicate**.
- 2 In the **Settings** window for **Volume**, locate the **Data** section.
- 3 From the **Dataset** list, choose **Study 1: Initial Design/Solution 1 (sol1)**.

4 Locate the **Coloring and Style** section. From the **Color** list, choose **Gray**.

Add a **Deformation** feature to avoid Z-fighting.

*Deformation 1 - Z-fighting perturbation fix*

1 Right-click **Volume 2** and choose **Deformation**.

2 In the **Settings** window for **Deformation**, type *Deformation 1 - Z-fighting perturbation fix* in the **Label** text field.

3 Locate the **Expression** section. In the **X-component** text field, type  $-(Xg+0.0975)*5e-4$ .

4 In the **Y-component** text field, type  $-(Yg-0.1)*5e-4$ .

5 In the **Z-component** text field, type  $-(Zg-0.046)*5e-4$ .

6 Locate the **Scale** section. Select the **Scale factor** checkbox.

*Line 1*

1 In the **Model Builder** window, right-click **Shape Optimization, Volumetric** and choose **Line**.

2 In the **Settings** window for **Line**, locate the **Data** section.

3 From the **Dataset** list, choose **Study 1: Initial Design/Solution 1 (sol1)**.

4 Locate the **Expression** section. In the **Expression** text field, type 1.

5 Locate the **Coloring and Style** section. From the **Coloring** list, choose **Uniform**.

6 From the **Color** list, choose **Gray**.

*Shape Optimization, Volumetric*

1 In the **Model Builder** window, click **Shape Optimization, Volumetric**.

2 In the **Shape Optimization, Volumetric** toolbar, click  **Plot**.

The optimization increases the fillet radius at the point of maximum stress.

*Cycles to Failure, Optimized*

1 In the **Model Builder** window, click **Cycles to Failure, Optimized**.

2 In the **Cycles to Failure, Optimized** toolbar, click  **Plot**.

The plot can be compared with the corresponding plot for the initial design.

