



# Chloroprene Rubber Compression Test

## *Introduction*

---

Elastomers and biological materials exhibit strain-rate dependent mechanical behavior and hysteresis when subjected to cyclical loads. The Bergstrom–Boyce material model has been successfully used to capture such phenomena in applications where these nonequilibrium effects are important. This example demonstrates the use of the **Polymer Viscoplasticity** feature available in the Nonlinear Structural Materials Module. The simulation results are compared with results found in the literature.

## *Model Definition*

---

In this model, a cylindrical rubber specimen with a height,  $H$ , of 13 mm and a diameter,  $D$ , of 68 mm, is subjected to compression following the true strain history shown in [Figure 1](#). The specimen is loaded at a constant true strain rate of 0.002 1/s and the strain is held constant for 120 s when the strain level reaches 0.3 and 0.6. The unloading phase is symmetric with respect to the loading phase. This strain history has been used to conduct the experimental tests on carbon-black-filled chloroprene rubber shown in [Ref. 2](#), and constitutes a test benchmark for the Bergstrom–Boyce numerical material model used also in [Ref. 1](#).

The geometry exhibits 2D axial symmetry as well as a reflection symmetry in the mid cross section of the cylinder. It is therefore possible to reduce the model geometry to a rectangle with height equal to half of the length of the specimen and a width equal to its radius.

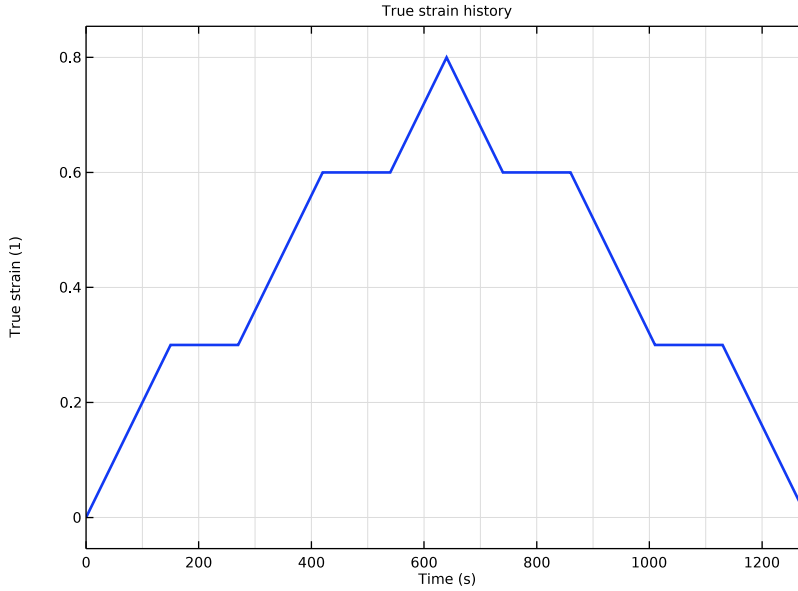

Figure 1: True strain time history.

### MATERIAL MODEL

The rheology of the Bergstrom–Boyce material model is shown in Figure 2. It features a so-called equilibrium network that can be schematized as a simple hyperelastic spring characterized by an Arruda–Boyce strain energy, in parallel with a second network that models the nonequilibrium behavior. This latter network comprises an isochoric Arruda–Boyce spring in series with a viscoplastic element whose rate multiplier is given by

$$\lambda = A(\lambda_{\text{vpe}} - 1 + \xi)^c \left( \frac{\sigma_{\text{vm}} - \sigma_{\text{co}}}{\sigma_{\text{res}}} \right)^n \quad (1)$$

when  $\sigma_{\text{vm}} - \sigma_{\text{co}}$  is positive and zero otherwise. Here,  $\sigma_{\text{vm}}$  is the von Mises stress of the nonequilibrium network and  $\sigma_{\text{co}}$  is a material parameter identifying a cutoff stress. The symbols  $A$ ,  $c$ ,  $n$ , and  $\sigma_{\text{res}}$  identify material properties. Moreover

$$\lambda_{\text{vpe}} = \sqrt{\frac{\text{tr}(\mathbf{F}_{\text{vp}} \mathbf{F}_{\text{vp}}^T)}{3}} \quad (2)$$

is a measure of the stretch in the viscoplastic element,  $F_{vp}$  being its deformation gradient. A small parameter

$$\xi = 0.001$$

is used to avoid singularities when  $F_{vp}$  is identity and the exponent  $c$  is negative.

The numerical values of the material properties used in the model are given in [Table 1](#). They are adapted from those used in [Ref. 1](#) and [Ref. 2](#) for the COMSOL Multiphysics implementation of the Bergstrom–Boyce model.

TABLE 1: MATERIAL PROPERTIES.

| Constant       | Value                      |
|----------------|----------------------------|
| $\sigma_{co}$  | 0 [MPa]                    |
| $A$            | $7 \cdot \sqrt{2/3}$ [1/s] |
| $\sigma_{res}$ | $\sqrt{3}$ [MPa]           |
| $n$            | 4                          |
| $c$            | -1                         |

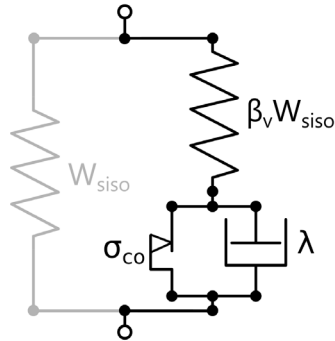

Figure 2: Rheology of the Bergstrom–Boyce material model.

## Results and Discussion

[Figure 3](#) shows the true stress versus true strain curve, comparing results with those found in the literature. It can be observed that during both the loading phase and the unloading phase, when the strain is held constant, the stress tends to the same equilibrium value, that is, the one given by the pure elastic network only at that strain value. This can be seen in [Figure 4](#), where the stress–strain curve obtained with the Bergstrom–Boyce model is compared to that obtained when the same strain history is applied to a pure hyperelastic

Arruda–Boyce model with the same material parameter as the equilibrium network of the Bergstrom–Boyce model. Note that the same equilibrium behavior can also be obtained performing a static analysis with the Bergstrom–Boyce material while using the **Long term** option for the stiffness used in stationary solver, that is, modeling the stress after infinite time.

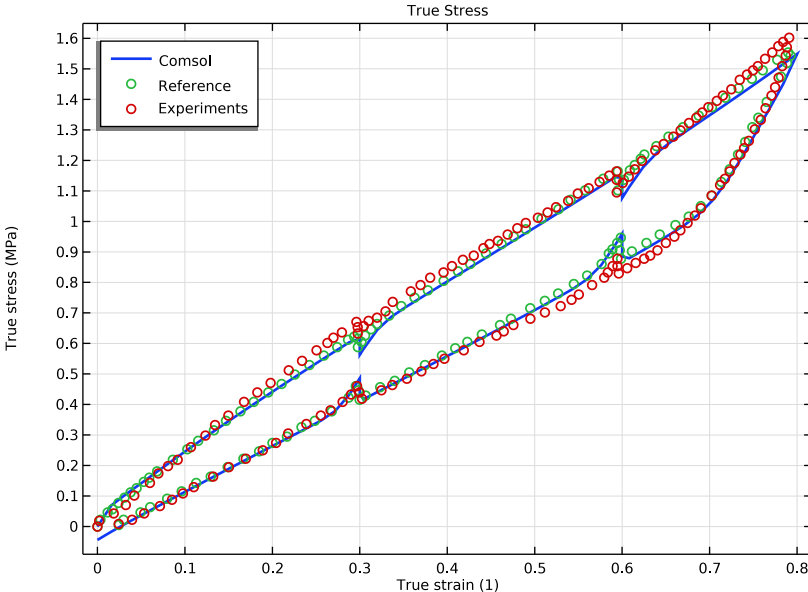

Figure 3: True stress versus true strain curve.

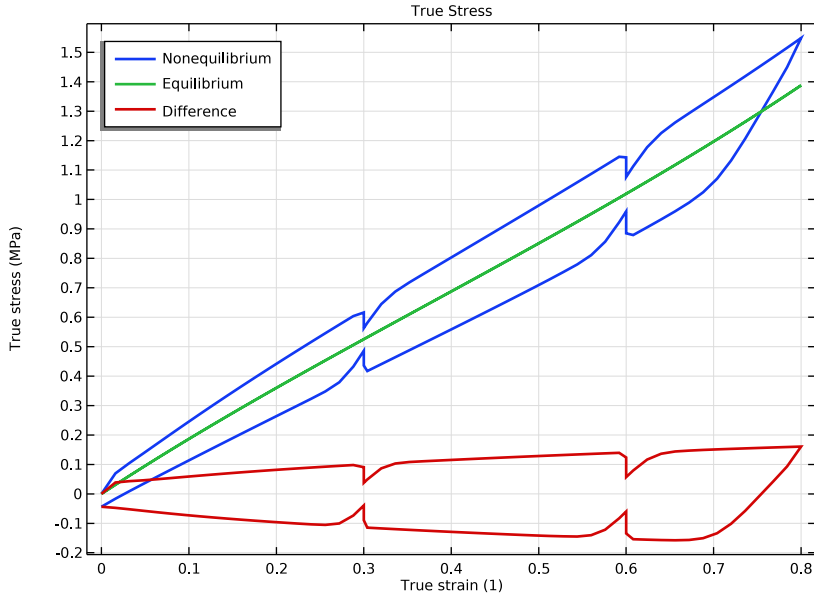

Figure 4: Comparison between the nonequilibrium behavior of the elastomeric material and the equilibrium one.

Figure 5 shows the total stretch of the specimen, along with the elastic and viscoplastic stretches of the nonequilibrium network. This shows that the stretch in the viscoplastic element is delayed with respect to the total stress, which makes the elastic stretch change sign during the unloading phase. The elastic element of the nonequilibrium element will thus be in tension during unloading instead of in compression, which reduces the overall compressive stress with respect to the equilibrium behavior.

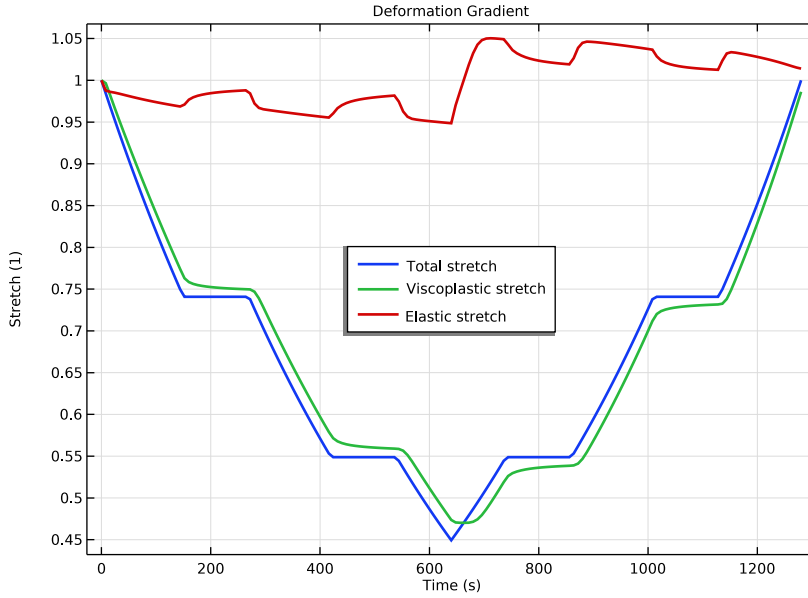

Figure 5: Comparison between the total stretch of the material, with the viscoplastic and elastic part of the stretch in the nonequilibrium network.

Figure 6 shows the magnitude of the force developed in the nonequilibrium network, normalized with respect to its maximum along the time axis. It can be observed how the force relaxes during the time spans where the strain is kept fixed.

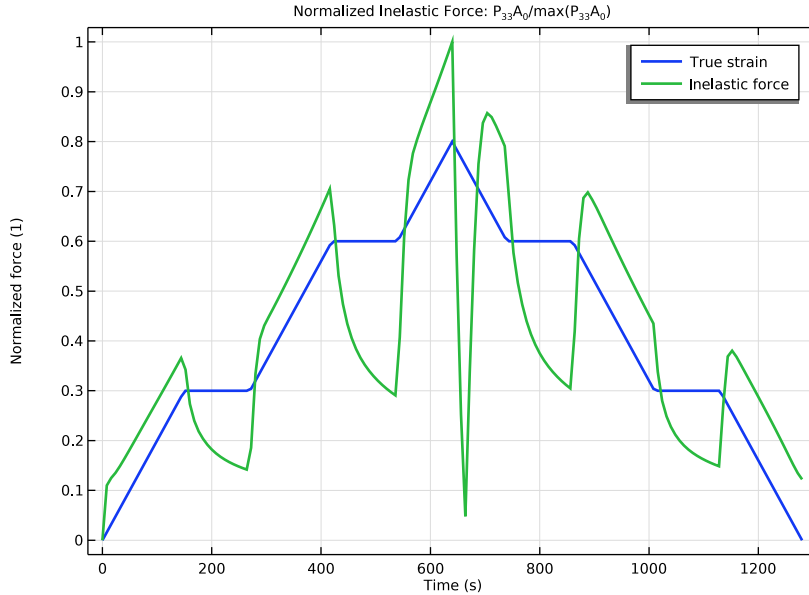

Figure 6: Force developed in the nonequilibrium network.

### Notes About the COMSOL Implementation

- You can use the Bergstrom–Boyce material model by adding a **Polymer Viscoplasticity** node under **Hyperelastic Material**.
- The desired true strain history can be imposed by applying a **Predscribed Displacement** node on the top surface of the specimen. The displacement can be computed as

$$u_{0z} = \frac{H}{2}(e^{\varepsilon(t)} - 1)$$

where  $\varepsilon(t)$  is the true strain.

- You find the **Domain ODEs** option in the **Time stepping** section of the **Polymer Viscoplasticity** node. This option can be faster than **Backward Euler** when the number of degrees of freedom is small.

## References

---

1. D. Husnu and M.Kaliske, “Bergstrom-Boyce model for nonlinear finite rubber viscoelasticity: theoretical aspects and algorithmic treatment for the FE method,” *Comput. Mech.*, vol. 44, pp. 809–823, 2009.
2. J.S. Bergström and M. Boyce, “Constitutive modeling of the large strain time-dependent behavior of elastomers,” *J. Mech. Phys. Solids*, vol. 46, pp. 931–954, 1998.

---

**Application Library path:** Nonlinear\_Structural\_Materials\_Module/  
Viscoplasticity/chloroprene\_rubber\_compression\_test

---

## Modeling Instructions



---

From the **File** menu, choose **New**.

### NEW

In the **New** window, click  **Model Wizard**.

### MODEL WIZARD

- 1 In the **Model Wizard** window, click  **2D Axisymmetric**.
- 2 In the **Select Physics** tree, select **Structural Mechanics > Solid Mechanics (solid)**.
- 3 Click **Add**.
- 4 Click  **Study**.
- 5 In the **Select Study** tree, select **General Studies > Time Dependent**.
- 6 Click  **Done**.

### GLOBAL DEFINITIONS

#### Geometrical Parameters

- 1 In the **Model Builder** window, under **Global Definitions** click **Parameters I**.
- 2 In the **Settings** window for **Parameters**, type Geometrical Parameters in the **Label** text field.

3 Locate the **Parameters** section. In the table, enter the following settings:

| Name | Expression          | Value                    | Description                   |
|------|---------------------|--------------------------|-------------------------------|
| H    | 13[mm]              | 0.013 m                  | Height of test specimen       |
| D    | 28[mm]              | 0.028 m                  | Diameter of test specimen     |
| A0   | $\pi \cdot D^2 / 4$ | 6.1575E-4 m <sup>2</sup> | Surface area of test specimen |

#### Strain History Data

1 In the **Home** toolbar, click  **Parameters** and choose **Add > Parameters**.

2 In the **Settings** window for **Parameters**, type Strain History Data in the **Label** text field.

3 Locate the **Parameters** section. In the table, enter the following settings:

| Name    | Expression | Value     | Description            |
|---------|------------|-----------|------------------------|
| edot    | 0.002[1/s] | 0.002 1/s | True strain rate       |
| Dt      | 150[s]     | 150 s     | Time before relaxation |
| Rt      | 120[s]     | 120 s     | Relaxation time        |
| endTime | 1280[s]    | 1280 s    | Total simulation time  |

#### GEOMETRY I

1 In the **Model Builder** window, under **Component 1 (comp1)** click **Geometry 1**.

2 In the **Settings** window for **Geometry**, locate the **Units** section.

3 From the **Length unit** list, choose **mm**.

#### Rectangle 1 (r1)

1 In the **Geometry** toolbar, click  **Rectangle**.

2 In the **Settings** window for **Rectangle**, locate the **Size and Shape** section.

3 In the **Width** text field, type D/2.

4 In the **Height** text field, type H/2.

5 Click  **Build Selected**.

6 Click  **Build All Objects**.

#### DEFINITIONS

##### Logarithmic Strain

1 In the **Definitions** toolbar, click  **Piecewise**.

2 In the **Settings** window for **Piecewise**, locate the **Definition** section.

3 In the **Argument** text field, type `time`.

4 Find the **Intervals** subsection. In the table, enter the following settings:

| Start            | End              | Function  |
|------------------|------------------|---|
| 0                | Dt               | $\text{edot} * \text{time}$   |
| Dt               | Dt+Rt            | $\text{edot} * \text{Dt}$   |
| Dt+Rt            | 2*Dt+Rt          | $\text{edot} * (\text{time} - \text{Rt})$                           |
| 2*Dt+Rt          | 2*(Dt+Rt)        | $2 * \text{edot} * \text{Dt}$                                       |
| 2*(Dt+Rt)        | 2*(Dt+Rt)+2*Dt/3 | $\text{edot} * (\text{time} - 2 * \text{Rt})$                       |
| 2*(Dt+Rt)+2*Dt/3 | 2*(Dt+Rt)+4*Dt/3 | $1 + \text{edot} * (2 * (\text{Dt} + \text{Rt}) - \text{time})$     |
| 2*(Dt+Rt)+4*Dt/3 | 2*Dt+3*Rt+4*Dt/3 | $2 * \text{edot} * \text{Dt}$                                       |
| 2*Dt+3*Rt+4*Dt/3 | 3*(Dt+Rt)+4*Dt/3 | $0.4 + \text{edot} * (3 * \text{Rt} + 4 * \text{Dt} - \text{time})$ |
| 3*(Dt+Rt)+4*Dt/3 | 3*Dt+4*Rt+4*Dt/3 | $\text{edot} * \text{Dt}$   |
| 3*Dt+4*Rt+4*Dt/3 | 4*(Dt+Rt)+4*Dt/3 | $0.4 + \text{edot} * (4 * \text{Rt} + 4 * \text{Dt} - \text{time})$ |

5 Locate the **Units** section. In the **Arguments** text field, type `s`.

6 In the **Function** text field, type `1`.

7 Click  **Plot**.

8 In the **Label** text field, type `Logarithmic Strain`.

#### Top Surface Average

1 In the **Definitions** toolbar, click  **Nonlocal Couplings** and choose **Average**.

2 In the **Settings** window for **Average**, locate the **Source Selection** section.

3 From the **Geometric entity level** list, choose **Boundary**.

4 Select **Boundary 3** only.

5 In the **Label** text field, type `Top Surface Average`.

#### SOLID MECHANICS (SOLID)

1 In the **Model Builder** window, under **Component 1 (comp1)** click **Solid Mechanics (solid)**.

2 In the **Settings** window for **Solid Mechanics**, locate the **Structural Transient Behavior** section.

3 From the list, choose **Quasistatic**.

#### Symmetry Plane 1

1 In the **Physics** toolbar, click  **Boundaries** and choose **Symmetry Plane**.

2 Select Boundary 2 only.

#### *Hyperelastic Material 1*

- 1 In the **Physics** toolbar, click  **Domains** and choose **Hyperelastic Material**.
- 2 In the **Settings** window for **Hyperelastic Material**, locate the **Hyperelastic Material** section.
- 3 From the **Material model** list, choose **Arruda–Boyce**.
- 4 From the **Compressibility** list, choose **Compressible, uncoupled**.
- 5 From the **Volumetric strain energy** list, choose **Miehe**.
- 6 Select Domain 1 only.

#### *Polymer Viscoplasticity 1*

- 1 In the **Physics** toolbar, click  **Attributes** and choose **Polymer Viscoplasticity**.
- 2 In the **Settings** window for **Polymer Viscoplasticity**, locate the **Viscoplasticity Model** section.
- 3 Find the **Hyperelastic element** subsection. In the  $\beta_v$  text field, type 1.6.
- 4 Locate the **Time Stepping** section. From the **Method** list, choose **Domain ODEs**.

#### *Prescribed Displacement 1*

- 1 In the **Physics** toolbar, click  **Boundaries** and choose **Prescribed Displacement**.
- 2 In the **Settings** window for **Prescribed Displacement**, locate the **Prescribed Displacement** section.
- 3 From the **Displacement in z direction** list, choose **Prescribed**.
- 4 In the  $u_{0z}$  text field, type  $0.5 * H * (\exp(-pw1(t)) - 1)$ .
- 5 Select Boundary 3 only.

## **MATERIALS**

#### *Material 1 (mat1)*

- 1 In the **Model Builder** window, under **Component 1 (comp1)** right-click **Materials** and choose **Blank Material**.
- 2 In the **Settings** window for **Material**, locate the **Material Contents** section.

3 In the table, enter the following settings:

| Property                      | Variable   | Value                      | Unit              | Property group                  |
|-------------------------------|------------|----------------------------|-------------------|---------------------------------|
| Bulk modulus                  | K          | 2 [GPa]                    | N/m <sup>2</sup>  | Bulk modulus and shear modulus  |
| Number of segments            | Nseg       | 8                          | l                 | Arruda-Boyce                    |
| Macroscopic shear modulus     | mu0        | 0.6 [MPa]                  | N/m <sup>2</sup>  | Arruda-Boyce                    |
| Density                       | rho        | 0                          | kg/m <sup>3</sup> | Basic                           |
| Viscoplastic rate coefficient | A_BB       | $7 \cdot \sqrt{2/3}$ [1/s] | 1/s               | Bergstrom-Boyce viscoplasticity |
| Flow resistance               | sigRes_BB  | $\sqrt{3}$ [MPa]           | N/m <sup>2</sup>  | Bergstrom-Boyce viscoplasticity |
| Stress exponent               | n_BB       | 4                          | l                 | Bergstrom-Boyce viscoplasticity |
| Cutoff stress                 | sigmaco_BB | 0                          | N/m <sup>2</sup>  | Bergstrom-Boyce viscoplasticity |
| Strain exponent               | c_BB       | -1                         | l                 | Bergstrom-Boyce viscoplasticity |

## MESH 1

*Mapped 1*

In the **Mesh** toolbar, click  **Mapped**.

*Distribution 1*

- 1 Right-click **Mapped 1** and choose **Distribution**.
- 2 Select Boundaries 2 and 4 only.
- 3 In the **Settings** window for **Distribution**, locate the **Distribution** section.
- 4 In the **Number of elements** text field, type 1.
- 5 Click  **Build All**.



## NONEQUILIBRIUM MODELING

- 1 In the **Model Builder** window, click **Study 1**.
- 2 In the **Settings** window for **Study**, type Nonequilibrium Modeling in the **Label** text field.
- 3 Locate the **Study Settings** section. Clear the **Generate default plots** checkbox.

*Step 1: Time Dependent*

- 1 In the **Model Builder** window, under **Nonequilibrium Modeling** click **Step 1: Time Dependent**.
- 2 In the **Settings** window for **Time Dependent**, locate the **Study Settings** section.
- 3 In the **Output times** text field, type range (0,8,endTime).



*Solution 1 (sol1)*

- 1 In the **Study** toolbar, click  **Show Default Solver**.
- 2 In the **Model Builder** window, expand the **Solution 1 (sol1)** node.
- 3 In the **Model Builder** window, expand the **Nonequilibrium Modeling > Solver Configurations > Solution 1 (sol1) > Time-Dependent Solver 1** node.
- 4 In the **Model Builder** window, expand the **Nonequilibrium Modeling > Solver Configurations > Solution 1 (sol1) > Dependent Variables 1** node, then click **Displacement Field (comp1.u)**.
- 5 In the **Settings** window for **Field**, locate the **Scaling** section.
- 6 In the **Scale** text field, type 0.005.
- 7 In the **Model Builder** window, under **Nonequilibrium Modeling > Solver Configurations > Solution 1 (sol1) > Dependent Variables 1** click **Equivalent Viscoplastic Strain (comp1.solid.hmml.pvpl.evpe)**.
- 8 In the **Settings** window for **Field**, locate the **Scaling** section.
- 9 In the **Scale** text field, type 1.
- 10 In the **Model Builder** window, under **Nonequilibrium Modeling > Solver Configurations > Solution 1 (sol1) > Dependent Variables 1** click **Viscoplastic Strain Tensor, Local Coordinate System (comp1.solid.hmml.pvpl.evp)**.
- 11 In the **Settings** window for **Field**, locate the **Scaling** section.
- 12 In the **Scale** text field, type 1.
- 13 In the **Model Builder** window, under **Nonequilibrium Modeling > Solver Configurations > Solution 1 (sol1)** click **Time-Dependent Solver 1**.
- 14 In the **Settings** window for **Time-Dependent Solver**, click to expand the **Time Stepping** section.
- 15 From the **Steps taken by solver** list, choose **Strict**.
- 16 In the **Study** toolbar, click  **Compute**.

Set default units for result presentation.

## RESULTS

### *Preferred Units 1*

- 1 In the **Results** toolbar, click  **Configurations** and choose **Preferred Units**.
- 2 In the **Settings** window for **Preferred Units**, locate the **Units** section.
- 3 Click  **Add Physical Quantity**.
- 4 In the **Physical Quantity** dialog, select **Solid Mechanics > Stress tensor (N/m<sup>2</sup>)** in the tree.
- 5 Click **OK**.
- 6 In the **Settings** window for **Preferred Units**, locate the **Units** section.
- 7 In the table, enter the following settings:

| Quantity      | Unit             | Preferred unit |
|---------------|------------------|----------------|
| Stress tensor | N/m <sup>2</sup> | MPa            |

- 8 Select the **Apply conversions to expressions with the same dimensions** checkbox.
- 9 Click  **Apply**.

### *Revolution 2D 1*

- 1 In the **Model Builder** window, expand the **Results > Datasets** node.
- 2 Right-click **Results > Datasets** and choose **Revolution 2D**.

### *Mirror 3D 1*

- 1 In the **Results** toolbar, click  **More Datasets** and choose **Mirror 3D**.
- 2 In the **Settings** window for **Mirror 3D**, locate the **Plane Data** section.
- 3 From the **Plane** list, choose **XY-planes**.

### *Displacements*

- 1 In the **Results** toolbar, click  **3D Plot Group**.
- 2 In the **Settings** window for **3D Plot Group**, type Displacements in the **Label** text field.
- 3 Locate the **Data** section. From the **Dataset** list, choose **Mirror 3D 1**.
- 4 Click to expand the **Title** section. From the **Title type** list, choose **Manual**.
- 5 In the **Title** text area, type Displacement magnitude [mm].
- 6 In the **Parameter indicator** text field, type Time=eval(τ) s.

### *Volume 1*

- 1 Right-click **Displacements** and choose **Volume**.
- 2 In the **Settings** window for **Volume**, locate the **Coloring and Style** section.

- 3 From the **Color table** list, choose **SpectrumLight**.

#### *Deformation I*

- 1 Right-click **Volume 1** and choose **Deformation**.
- 2 In the **Settings** window for **Deformation**, locate the **Scale** section.
- 3 Select the **Scale factor** checkbox. In the associated text field, type 1.

#### *Displacements*

- 1 In the **Model Builder** window, under **Results** click **Displacements**.
- 2 In the **Displacements** toolbar, click  **Plot**.

#### *Stretch History*

- 1 In the **Results** toolbar, click  **ID Plot Group**.
- 2 In the **Settings** window for **ID Plot Group**, type Stretch History in the **Label** text field.
- 3 Click to expand the **Title** section. From the **Title type** list, choose **Manual**.
- 4 In the **Title** text area, type Deformation Gradient.
- 5 Locate the **Plot Settings** section.
- 6 Select the **y-axis label** checkbox. In the associated text field, type Stretch (1).

#### *Global I*

- 1 Right-click **Stretch History** and choose **Global**.
- 2 In the **Settings** window for **Global**, locate the **y-Axis Data** section.
- 3 In the table, enter the following settings:

| <b>Expression</b>                             | <b>Unit</b> | <b>Description</b>   |
|---|-------------|----------------------|
| aveop1(solid.FdzZ)                            | 1           | Total stretch        |
| aveop1(solid.hmm1.pvp1.Fvp133)                | 1           | Viscoplastic stretch |
| aveop1(solid.hmm1.pvp1.Fvp133*<br>solid.FdzZ) | 1           | Elastic stretch      |

- 4 Click to expand the **Coloring and Style** section. From the **Width** list, choose 2.

#### *Stretch History*

- 1 In the **Model Builder** window, click **Stretch History**.
- 2 In the **Settings** window for **ID Plot Group**, locate the **Legend** section.
- 3 From the **Position** list, choose **Center**.
- 4 In the **Stretch History** toolbar, click  **Plot**.

### True Stress

- 1 In the **Results** toolbar, click  **ID Plot Group**.
- 2 In the **Settings** window for **ID Plot Group**, type True Stress in the **Label** text field.
- 3 Locate the **Title** section. From the **Title type** list, choose **Manual**.
- 4 In the **Title** text area, type True Stress.
- 5 Locate the **Plot Settings** section.
- 6 Select the **x-axis label** checkbox. In the associated text field, type True strain (1).
- 7 Select the **y-axis label** checkbox. In the associated text field, type True stress (MPa).

### Global I

- 1 Right-click **True Stress** and choose **Global**.
- 2 In the **Settings** window for **Global**, locate the **y-Axis Data** section.
- 3 In the table, enter the following settings:

| Expression         | Unit | Description         |
|--------------------|------|---------------------|
| aveop1(-solid.szz) | MPa  | Top Surface Average |



- 4 Locate the **x-Axis Data** section. From the **Parameter** list, choose **Expression**.
- 5 In the **Expression** text field, type aveop1(abs(solid.e1ogzz)).
- 6 Locate the **Coloring and Style** section. From the **Width** list, choose **2**.
- 7 Click to expand the **Legends** section. From the **Legends** list, choose **Manual**.
- 8 In the table, enter the following settings:

| Legends |
|---------|
| Comsol  |

### True Stress

- 1 In the **Model Builder** window, click **True Stress**.
  - 2 In the **Settings** window for **ID Plot Group**, locate the **Legend** section.
  - 3 From the **Position** list, choose **Upper left**.
- Import results from [Ref. 1](#) in a table to plot them along with the simulation results.

### Reference Results

- 1 In the **Results** toolbar, click  **Table**.
- 2 In the **Settings** window for **Table**, type Reference Results in the **Label** text field.
- 3 Locate the **Data** section. Click  **Import**.

- 4 Browse to the model's Application Libraries folder and double-click the file `chloroprene_rubber_compression_test_numerical.txt`.

#### *Table Graph 1*



- 1 Right-click **True Stress** and choose **Table Graph**.
- 2 In the **Settings** window for **Table Graph**, locate the **Coloring and Style** section.
- 3 Find the **Line style** subsection. From the **Line** list, choose **None**.
- 4 Find the **Line markers** subsection. From the **Marker** list, choose **Circle**.
- 5 Click to expand the **Legends** section. Select the **Show legends** checkbox.
- 6 From the **Legends** list, choose **Manual**.
- 7 In the table, enter the following settings:

---

| <b>Legends</b> |
|----------------|
| Reference      |

---

#### *Experimental Results*

- 1 In the **Results** toolbar, click  **Table**.
- 2 In the **Settings** window for **Table**, type `Experimental Results` in the **Label** text field.
- 3 Locate the **Data** section. Click  **Import**.
- 4 Browse to the model's Application Libraries folder and double-click the file `chloroprene_rubber_compression_test_experimental.txt`.

#### *Table Graph 2*

- 1 Right-click **True Stress** and choose **Table Graph**.
- 2 In the **Settings** window for **Table Graph**, locate the **Data** section.
- 3 From the **Table** list, choose **Experimental Results**.
- 4 Locate the **Coloring and Style** section. Find the **Line style** subsection. From the **Line** list, choose **None**.
- 5 Find the **Line markers** subsection. From the **Marker** list, choose **Circle**.
- 6 Locate the **Legends** section. Select the **Show legends** checkbox.
- 7 From the **Legends** list, choose **Manual**.
- 8 In the table, enter the following settings:

---

| <b>Legends</b> |
|----------------|
| Experiments    |

---

- 9 In the **True Stress** toolbar, click  **Plot**.

### Comparison 1

- 1 In the **Model Builder** window, right-click **Global 1** and choose **Comparison**.
- 2 In the **Settings** window for **Comparison**, locate the **Comparison** section.
- 3 From the **Metric** list, choose **Coefficient of determination**.
- 4 In the **True Stress** toolbar, click  **Plot**.

### Inelastic Force Contribution

- 1 In the **Results** toolbar, click  **ID Plot Group**.
- 2 In the **Settings** window for **ID Plot Group**, type Inelastic Force Contribution in the **Label** text field.
- 3 Locate the **Title** section. From the **Title type** list, choose **Manual**.
- 4 In the **Title** text area, type Normalized Inelastic Force:  $\frac{P_{33}}{A_0} / \max(P_{33}/A_0)$ .
- 5 Locate the **Plot Settings** section.
- 6 Select the **y-axis label** checkbox. In the associated text field, type Normalized force (1).

### Global 1

- 1 Right-click **Inelastic Force Contribution** and choose **Global**.
- 2 In the **Settings** window for **Global**, locate the **y-Axis Data** section.
- 3 In the table, enter the following settings:

| Expression                | Unit | Description |
|---------------------------|------|-------------|
| aveop1(abs(solid.eIogzz)) | 1    | True strain |

- 4 Locate the **Coloring and Style** section. From the **Width** list, choose **2**.

### Max Inelastic Force

- 1 In the **Results** toolbar, click  **Point Evaluation**.
- 2 In the **Settings** window for **Point Evaluation**, type Max Inelastic Force in the **Label** text field.
- 3 Select Point 2 only.
- 4 Locate the **Expressions** section. In the table, enter the following settings:

| Expression  | Unit | Description |
|---|------|-------------|
| timemax(0,endTime,abs(solid.Fdlz3*solid.Siel33*A0)) | N    |             |

- 5 Locate the **Data** section. From the **Time selection** list, choose **First**.
- 6 Click  **Evaluate**.

#### *Global 1*



- 1 In the **Model Builder** window, under **Results** > **Inelastic Force Contribution** click **Global 1**.
- 2 In the **Settings** window for **Global**, locate the **y-Axis Data** section.
- 3 In the table, enter the following settings:

| Expression  | Unit | Description     |
|---|------|-----------------|
| aveop1 (abs(solid.Fdlz3*solid.Siel33*A0) / 146.75[N]) | 1    | Inelastic force |

- 4 In the **Inelastic Force Contribution** toolbar, click  **Plot**.

Add a new study to compute the equilibrium behavior.

#### **ADD STUDY**

- 1 In the **Home** toolbar, click  **Add Study** to open the **Add Study** window.
- 2 Go to the **Add Study** window.
- 3 Find the **Studies** subsection. In the **Select Study** tree, select **General Studies** > **Time Dependent**.
- 4 Click the **Add Study** button in the window toolbar.
- 5 In the **Home** toolbar, click  **Add Study** to close the **Add Study** window.



#### **EQUILIBRIUM MODELING**

- 1 In the **Settings** window for **Study**, type Equilibrium Modeling in the **Label** text field.
- 2 Locate the **Study Settings** section. Clear the **Generate default plots** checkbox.

#### *Step 1: Time Dependent*

- 1 In the **Model Builder** window, under **Equilibrium Modeling** click **Step 1: Time Dependent**.
- 2 In the **Settings** window for **Time Dependent**, locate the **Study Settings** section.
- 3 In the **Output times** text field, type range (0,8,endTime).
- 4 Locate the **Physics and Variables Selection** section. Select the **Modify model configuration for study step** checkbox.
- 5 In the tree, select **Component 1 (comp1)** > **Solid Mechanics (solid)**, **Controls spatial frame** > **Hyperelastic Material 1** > **Polymer Viscoplasticity 1**.
- 6 Right-click and choose **Disable**.

### *Solution 2 (sol2)*

- 1 In the **Study** toolbar, click  **Show Default Solver**.
- 2 In the **Model Builder** window, expand the **Solution 2 (sol2)** node, then click **Time-Dependent Solver 1**.
- 3 In the **Settings** window for **Time-Dependent Solver**, locate the **Time Stepping** section.
- 4 From the **Steps taken by solver** list, choose **Strict**.
- 5 In the **Model Builder** window, expand the **Equilibrium Modeling > Solver Configurations > Solution 2 (sol2) > Time-Dependent Solver 1** node, then click **Fully Coupled 1**.
- 6 In the **Settings** window for **Fully Coupled**, click to expand the **Method and Termination** section.
- 7 From the **Nonlinear method** list, choose **Automatic (Newton)**.
- 8 In the **Model Builder** window, expand the **Equilibrium Modeling > Solver Configurations > Solution 2 (sol2) > Dependent Variables 1** node, then click **Displacement Field (comp1.u)**.
- 9 In the **Settings** window for **Field**, locate the **Scaling** section.
- 10 In the **Scale** text field, type 0.005.
- 11 In the **Study** toolbar, click  **Compute**.

## **RESULTS**

### *Nonequilibrium vs. Equilibrium*

- 1 In the **Results** toolbar, click  **ID Plot Group**.
- 2 In the **Settings** window for **ID Plot Group**, type Nonequilibrium vs. Equilibrium in the **Label** text field.
- 3 Locate the **Title** section. From the **Title type** list, choose **Manual**.
- 4 In the **Title** text area, type True Stress.
- 5 Locate the **Plot Settings** section.
- 6 Select the **x-axis label** checkbox. In the associated text field, type True strain (1).
- 7 Select the **y-axis label** checkbox. In the associated text field, type True stress (MPa).
- 8 Locate the **Legend** section. From the **Position** list, choose **Upper left**.

### *Nonequilibrium*

- 1 Right-click **Nonequilibrium vs. Equilibrium** and choose **Global**.
- 2 In the **Settings** window for **Global**, type Nonequilibrium in the **Label** text field.

3 Locate the **y-Axis Data** section. In the table, enter the following settings:

| Expression         | Unit | Description         |
|--------------------|------|---------------------|
| aveop1(-solid.szz) | MPa  | Top Surface Average |

4 Locate the **Coloring and Style** section. From the **Width** list, choose **2**.

5 Locate the **Legends** section. Find the **Include** subsection. Select the **Label** checkbox.

6 Clear the **Solution** checkbox.

7 Clear the **Description** checkbox.

8 Locate the **x-Axis Data** section. From the **Parameter** list, choose **Expression**.

9 In the **Expression** text field, type `aveop1(abs(solid.e1ogzz))`.

#### *Equilibrium*

1 Right-click **Nonequilibrium** and choose **Duplicate**.

2 In the **Settings** window for **Global**, type **Equilibrium** in the **Label** text field.

3 Locate the **Data** section. From the **Dataset** list, choose **Equilibrium Modeling/ Solution 2 (sol2)**.

#### *Difference*

1 In the **Model Builder** window, right-click **Nonequilibrium** and choose **Duplicate**.

2 In the **Settings** window for **Global**, type **Difference** in the **Label** text field.

3 Locate the **y-Axis Data** section. In the table, enter the following settings:

| Expression  | Unit | Description |
|---|------|-------------|
| aveop1(-solid.szz)-withsol('sol2',aveop1(-solid.szz),setval(t,t)) | MPa  |             |

4 In the **Nonequilibrium vs. Equilibrium** toolbar, click  **Plot**.