

Piezoelectric Valve

Introduction

Piezoelectric valves are frequently employed in medical and laboratory applications. They have a number of advantages over competing technologies, including minimal heat dissipation, quiet operation, energy efficiency, durability, low weight and fast response times. These valves typically consist of a seal that is pushed up against an opening to close the valve, or moved away from the opening to open the valve, by a piezoelectric actuator. The actuator itself often has a complex internal structure, with stacked layers of piezoelectric separated by thin conducting layers that are connected together in such a way that the applied field leads to a large deformation.

This model shows how to model a piezoelectric valve in COMSOL. The valve is actuated by a stacked piezoelectric bimorph disc actuator, which compresses a hyperelastic seal against the valve opening to shut off the flow. The detailed construction and operation of the stacked actuator is considered in the model.

Note: This application requires the Nonlinear Structural Materials Module.

Model Definition

[Figure 1](#) shows both an axisymmetric slice through the geometry and a 3D rendering of the geometry. In this simple valve design a disc actuator compresses a hyperelastic seal directly onto an annular opening in a stainless steel support structure. The construction of the actuator itself is illustrated in [Figure 2](#). The outer edge of the disc annulus is clamped to a stainless steel base and supporting structure. When a voltage is applied to the actuator the disc bends causing a vertical motion of the central opening of the annular actuator. With an appropriate polarity the opening moves downward, toward an annular opening in the base (supported at regular intervals by struts not included in the model). As the actuator moves toward the opening a hyperelastic seal is compressed against a mating structure, sealing up the opening. Within the model, the contact between the seal and the mating structure is modeled in detail, as is the operation of the actuator.

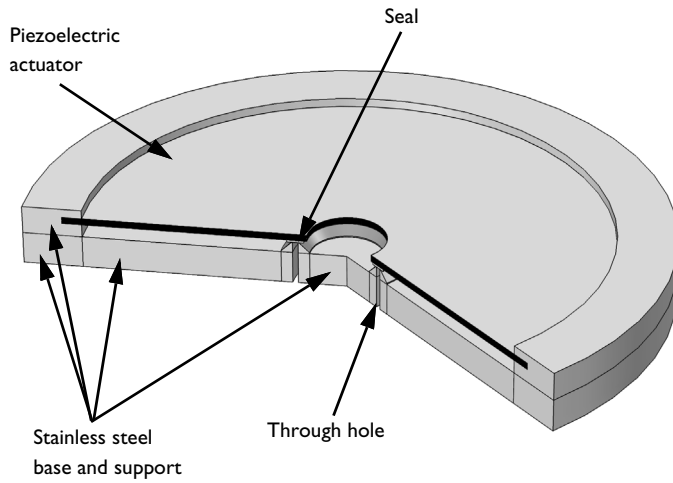
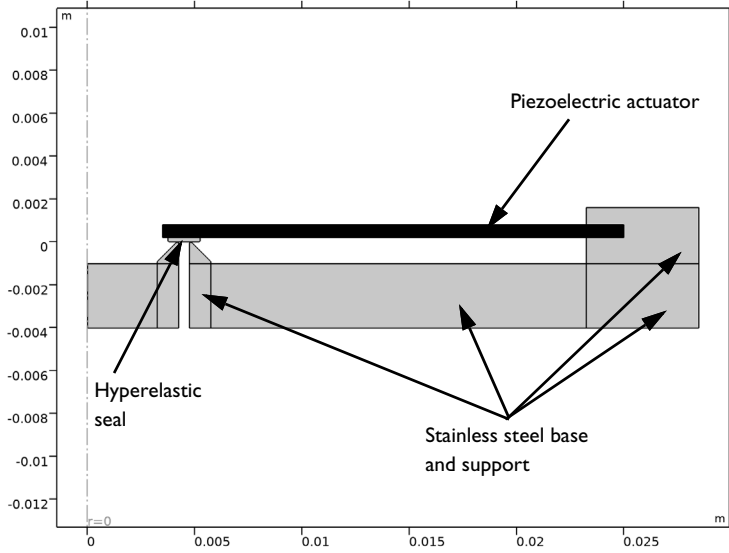

Figure 1: Axisymmetric model geometry (top) and full 3D geometry (bottom). Key components of the geometry are labeled.

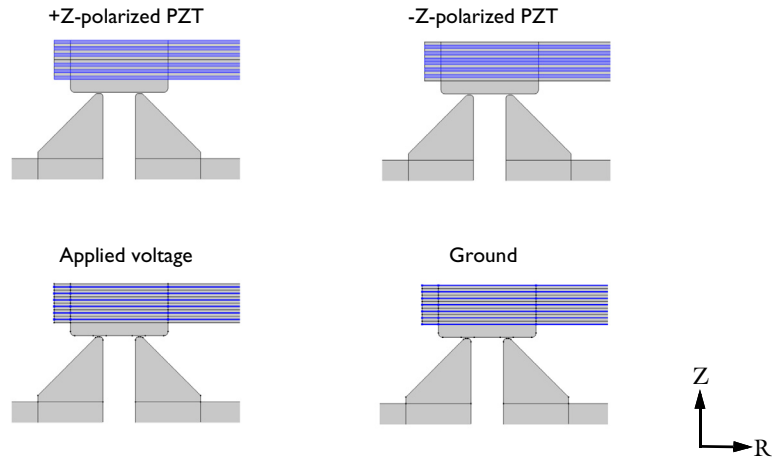

Figure 2: Detail of the actuator and seal region, showing the construction of the actuator itself. The actuator consists of layers of PZT with metal layers between the various layers. Alternate metal layers are connected to ground whilst a voltage is applied to the other layers. Alternate layers of PZT are polarized in opposite directions. Two such actuators are stacked in such a manner that the applied potential causes contraction of one half of the beam and expansion of the other half. This results in a net bending moment acting on the beam.

Results and Discussion

Figure 3 shows the strain in the hyperelastic seal when the applied voltage is 60 V. The strain is localized in the vicinity of the contact region. Figure 4 shows the von Mises strain in the piezoelectric and its supporting structures at the same applied voltage. The stress is maximal in the PZT close to the contact. The potential within the actuator is shown in Figure 5. It is clear that the applied potentials match those shown in Figure 2. Finally the contact pressure is shown in Figure 6. The maximum pressure is 6×10^5 Pa on the surface of the seal that separates the inlet of the valve from the outlet.

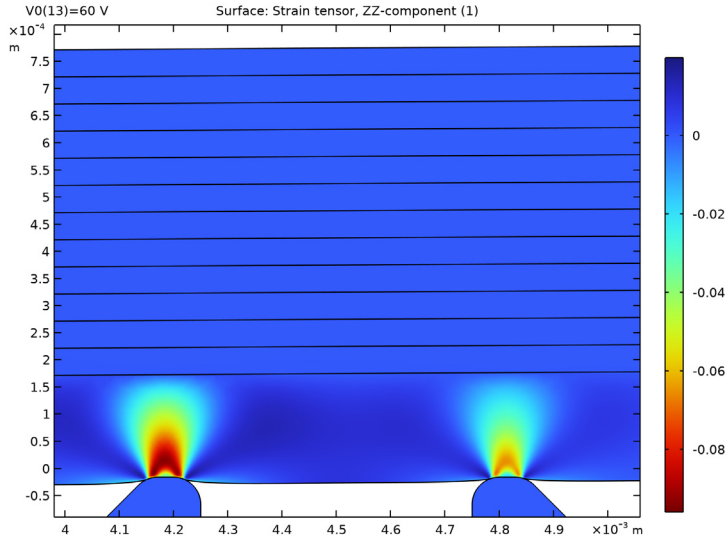

Figure 3: ZZ component of the strain in the vicinity of the contact.

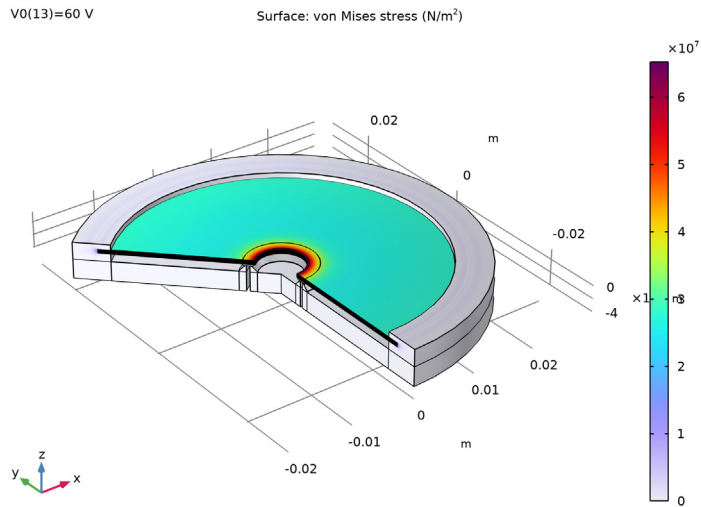

Figure 4: Three-dimensional visualization of the von Mises stress in the valve at an applied voltage of 50 V.

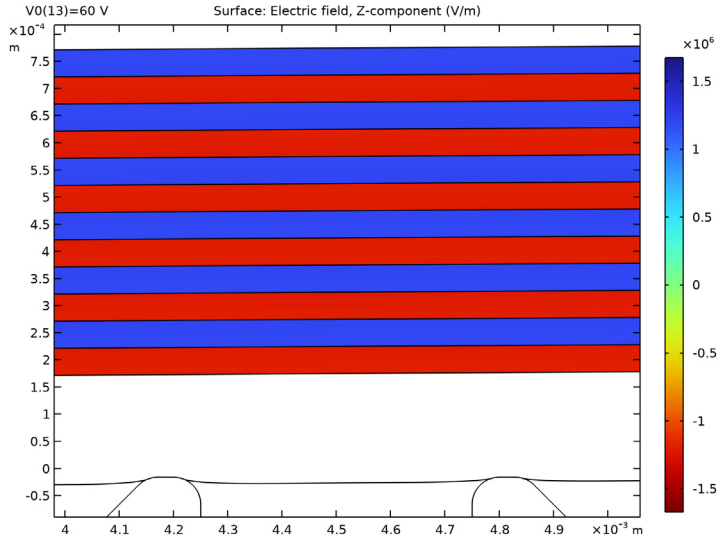

Figure 5: Electric field inside the actuator in the vicinity of the contact.

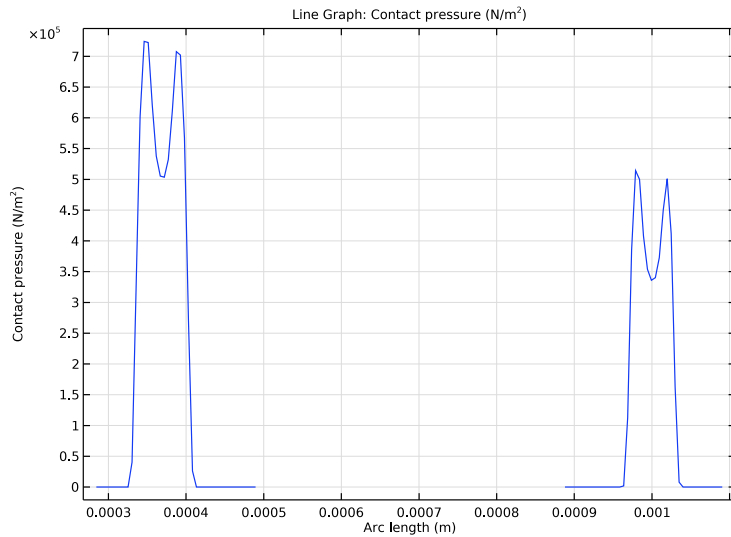

Figure 6: Contact pressure as a function of position along the surface of the seal.

Application Library path: MEMS_Module/Piezoelectric_Devices/
piezoelectric_valve



Modeling Instructions

From the **File** menu, choose **New**.

NEW

In the **New** window, click  **Model Wizard**.

MODEL WIZARD

- 1 In the **Model Wizard** window, click  **2D Axisymmetric**.
- 2 In the **Select Physics** tree, select **Structural Mechanics > Electromagnetics–Structure Interaction > Piezoelectricity > Piezoelectricity, Solid**.
- 3 Click **Add**.
- 4 Click  **Study**.
- 5 In the **Select Study** tree, select **General Studies > Stationary**.
- 6 Click  **Done**.

GEOMETRY I

For convenience, the device geometry is inserted from an existing file. You can read the instructions for creating the geometry in the [Appendix — Geometry Instructions](#).

- 1 In the **Geometry** toolbar, click **Insert Sequence** and choose **Insert Sequence**.
- 2 Browse to the model's Application Libraries folder and double-click the file `piezoelectric_valve_geom_sequence.mph`.
- 3 In the **Geometry** toolbar, click  **Build All**.

GLOBAL DEFINITIONS

Parameters I

- 1 In the **Model Builder** window, under **Global Definitions** click **Parameters I**.
- 2 In the **Settings** window for **Parameters**, locate the **Parameters** section.

3 In the table, enter the following settings:

Name	Expression	Value	Description
V0	50[V]	50 V	Applied voltage

DEFINITIONS



+ Polarized

- 1 In the **Definitions** toolbar, click  **Explicit**.
- 2 Select Domains 5, 7, 9, 10, 12, 14, 18, 20, 22, 23, 25, 27, 32, 34, 36, 37, 39, 41, 47, 49, 51, 52, 54, and 56 only.
- 3 In the **Settings** window for **Explicit**, type + Polarized in the **Label** text field.

- Polarized

- 1 In the **Definitions** toolbar, click  **Explicit**.
- 2 In the **Settings** window for **Explicit**, type - Polarized in the **Label** text field.
- 3 Select Domains 4, 6, 8, 11, 13, 15, 17, 19, 21, 24, 26, 28, 31, 33, 35, 38, 40, 42, 46, 48, 50, 53, 55, and 57 only.

Piezoelectric

- 1 In the **Definitions** toolbar, click  **Union**.
- 2 In the **Settings** window for **Union**, type Piezoelectric in the **Label** text field.
- 3 Locate the **Input Entities** section. Under **Selections to add**, click  **Add**.
- 4 In the **Add** dialog, in the **Selections to add** list, choose **+ Polarized** and **- Polarized**.
- 5 Click **OK**.

Ground

- 1 In the **Definitions** toolbar, click  **Explicit**.
- 2 In the **Settings** window for **Explicit**, locate the **Input Entities** section.
- 3 From the **Geometric entity level** list, choose **Boundary**.
- 4 In the **Label** text field, type Ground.
- 5 Select Boundaries 10, 14, 18, 22, 26, 30, 33, 36, 40, 44, 48, 52, 56, 59, 76, 80, 84, 88, 92, 96, 99, 109, 113, 117, 121, 125, 129, and 133 only.

Voltage



- 1 In the **Definitions** toolbar, click  **Explicit**.
- 2 In the **Settings** window for **Explicit**, type Voltage in the **Label** text field.

- 3 Locate the **Input Entities** section. From the **Geometric entity level** list, choose **Boundary**.
- 4 Select Boundaries 12, 16, 20, 24, 28, 32, 38, 42, 46, 50, 54, 58, 78, 82, 86, 90, 94, 98, 111, 115, 119, 123, 127, and 131 only.



Mapped Mesh Steel

- 1 In the **Definitions** toolbar, click  **Explicit**.
- 2 In the **Settings** window for **Explicit**, type Mapped Mesh Steel in the **Label** text field.
- 3 Select Domains 1, 2, 29, 43, and 44 only.

Mapped Mesh

- 1 In the **Definitions** toolbar, click  **Union**.
- 2 In the **Settings** window for **Union**, locate the **Input Entities** section.
- 3 Under **Selections to add**, click  **Add**.
- 4 In the **Add** dialog, in the **Selections to add** list, choose **Piezoelectric** and **Mapped Mesh Steel**.
- 5 Click **OK**.
- 6 In the **Settings** window for **Union**, type Mapped Mesh in the **Label** text field.

Contact Pair 1 (p1)

- 1 In the **Definitions** toolbar, click  **Pairs** and choose **Contact Pair**.
- 2 Select Boundaries 8, 62, 71, 72, and 150–153 only.
- 3 In the **Settings** window for **Pair**, locate the **Destination Boundaries** section.
- 4 Click to select the  **Activate Selection** toggle button.
- 5 Select Boundaries 61 and 66 only.

+Z Polarized

- 1 In the **Model Builder** window, under **Component 1 (comp1) > Definitions** click **Material XZ-plane System (comp1_xz_sys)**.
- 2 In the **Settings** window for **Base Vector System**, type +Z Polarized in the **Label** text field.

-Z Polarized

- 1 Right-click **+Z Polarized** and choose **Duplicate**.
- 2 In the **Settings** window for **Base Vector System**, locate the **Base Vectors** section.

3 In the table, enter the following settings:

	r	z
x1	1	0
x3	0	-1

4 In the **Label** text field, type -Z Polarized.

SOLID MECHANICS (SOLID)

Piezoelectric Material 2

- 1 In the **Physics** toolbar, click  **Domains** and choose **Piezoelectric Material**.
- 2 In the **Settings** window for **Piezoelectric Material**, locate the **Coordinate System Selection** section.
- 3 From the **Coordinate system** list, choose **-Z Polarized (comp1_xz_sys1)**.
- 4 Locate the **Domain Selection** section. From the **Selection** list, choose **- Polarized**.

Piezoelectric Material 1

- 1 In the **Model Builder** window, click **Piezoelectric Material 1**.
- 2 In the **Settings** window for **Piezoelectric Material**, locate the **Domain Selection** section.
- 3 From the **Selection** list, choose **+ Polarized**.

Hyperelastic Material 1

- 1 In the **Physics** toolbar, click  **Domains** and choose **Hyperelastic Material**.
- 2 Select Domain 16 only.
- 3 In the **Settings** window for **Hyperelastic Material**, locate the **Hyperelastic Material** section.
- 4 From the **Material model** list, choose **Mooney–Rivlin, two parameters**.
- 5 In the κ text field, type $1e4$ [MPa].

Fixed Constraint 1

- 1 In the **Physics** toolbar, click  **Domains** and choose **Fixed Constraint**.
- 2 Select Domains 1, 2, 29, 43, and 44 only.

Contact 1a

- 1 In the **Physics** toolbar, click  **Pairs** and choose **Contact**.
- 2 In the **Settings** window for **Contact**, locate the **Pair Selection** section.
- 3 Click **+ Add**.
- 4 In the **Add** dialog, select **Contact Pair 1 (p1)** in the **Pairs** list.

- 5 Click **OK**.
- 6 In the **Settings** window for **Contact**, locate the **Contact Method** section.
- 7 From the list, choose **Augmented Lagrangian**.

ELECTROSTATICS (ES)

- 1 In the **Model Builder** window, under **Component 1 (comp1)** click **Electrostatics (es)**.
- 2 In the **Settings** window for **Electrostatics**, locate the **Domain Selection** section.
- 3 From the **Selection** list, choose **Piezoelectric**.

Terminal 1

- 1 In the **Physics** toolbar, click  **Boundaries** and choose **Terminal**.
- 2 In the **Settings** window for **Terminal**, locate the **Boundary Selection** section.
- 3 From the **Selection** list, choose **Voltage**.
- 4 Locate the **Terminal** section. From the **Terminal type** list, choose **Voltage**.
- 5 In the V_0 text field, type V_0 .

Ground 1

- 1 In the **Physics** toolbar, click  **Boundaries** and choose **Ground**.
- 2 In the **Settings** window for **Ground**, locate the **Boundary Selection** section.
- 3 From the **Selection** list, choose **Ground**.

ADD MATERIAL

- 1 In the **Materials** toolbar, click  **Add Material** to open the **Add Material** window.
- 2 Go to the **Add Material** window.
- 3 In the tree, select **Piezoelectric > Lead Zirconate Titanate (PZT-5H)**.
- 4 Right-click and choose **Add to Component 1 (comp1)**.
- 5 In the tree, select **Built-in > Steel AISI 4340**.
- 6 Right-click and choose **Add to Component 1 (comp1)**.

MATERIALS

Lead Zirconate Titanate (PZT-5H) (mat1)

- 1 In the **Model Builder** window, under **Component 1 (comp1) > Materials** click **Lead Zirconate Titanate (PZT-5H) (mat1)**.
- 2 In the **Settings** window for **Material**, locate the **Geometric Entity Selection** section.
- 3 From the **Selection** list, choose **Piezoelectric**.

Steel AISI 4340 (mat2)

- 1 In the **Model Builder** window, click **Steel AISI 4340 (mat2)**.
- 2 Select Domains 1–3, 29, 30, and 43–45 only.

Seal

- 1 In the **Model Builder** window, right-click **Materials** and choose **Blank Material**.
- 2 In the **Settings** window for **Material**, type Seal in the **Label** text field.
- 3 Select Domain 16 only.
- 4 Locate the **Material Contents** section. In the table, enter the following settings:

Property	Variable	Value	Unit	Property group
Model parameters	C10	0.37 [MPa]	Pa	Mooney-Rivlin
Model parameters	C01	0.11 [MPa]	Pa	Mooney-Rivlin
Density	rho	1800 [kg/m ³]	kg/m ³	Basic

- 5 In the **Materials** toolbar, click  **Add Material** to close the **Add Material** window.

MESH 1

Edge 1

- 1 In the **Mesh** toolbar, click  **More Generators** and choose **Edge**.
- 2 Select Boundaries 61, 62, 66, 71, and 150–153 only.

Size 1

- 1 Right-click **Edge 1** and choose **Size**.
- 2 In the **Settings** window for **Size**, locate the **Geometric Entity Selection** section.
- 3 Click  **Clear Selection**.
- 4 Select Boundaries 61 and 66 only.
- 5 Locate the **Element Size** section. From the **Predefined** list, choose **Extremely fine**.
- 6 Click the **Custom** button.
- 7 Locate the **Element Size Parameters** section.
- 8 Select the **Maximum element size** checkbox. In the associated text field, type $w_0/100$.

Size 2

- 1 In the **Model Builder** window, right-click **Edge 1** and choose **Size**.
- 2 In the **Settings** window for **Size**, locate the **Geometric Entity Selection** section.
- 3 Click  **Clear Selection**.

- 4 Select Boundaries 62, 71, and 150–153 only.
- 5 Locate the **Element Size** section. From the **Predefined** list, choose **Extremely fine**.
- 6 Click the **Custom** button.
- 7 Locate the **Element Size Parameters** section.
- 8 Select the **Maximum element size** checkbox. In the associated text field, type $w0/50$.

Size

- 1 In the **Model Builder** window, under **Component 1 (comp1) > Mesh 1** click **Size**.
- 2 In the **Settings** window for **Size**, locate the **Element Size** section.
- 3 From the **Predefined** list, choose **Extremely fine**.
- 4 Click the **Custom** button.
- 5 Locate the **Element Size Parameters** section. In the **Maximum element size** text field, type $w0$.

Mapped 1

- 1 In the **Mesh** toolbar, click  **Mapped**.
- 2 In the **Settings** window for **Mapped**, locate the **Domain Selection** section.
- 3 From the **Geometric entity level** list, choose **Domain**.
- 4 From the **Selection** list, choose **Mapped Mesh**.

Distribution 1

- 1 Right-click **Mapped 1** and choose **Distribution**.
- 2 Select Boundaries 75, 77, 79, 81, 83, 85, 87, 89, 91, 93, 95, and 97 only.
- 3 In the **Settings** window for **Distribution**, locate the **Distribution** section.
- 4 In the **Number of elements** text field, type 2.

Distribution 2

- 1 In the **Model Builder** window, right-click **Mapped 1** and choose **Distribution**.
- 2 Select Boundaries 36 and 109 only.
- 3 In the **Settings** window for **Distribution**, locate the **Distribution** section.
- 4 In the **Number of elements** text field, type 40.

Distribution 3

- 1 Right-click **Mapped 1** and choose **Distribution**.
- 2 In the **Settings** window for **Distribution**, locate the **Distribution** section.
- 3 In the **Number of elements** text field, type 1.

4 Select Boundaries 2, 63, 67, and 101 only.

Free Triangular 1

1 In the **Mesh** toolbar, click  **Free Triangular**.

2 In the **Settings** window for **Free Triangular**, click  **Build All**.

Compare the resulting mesh with that shown below. Note that there are purposefully very few elements in the rigid domains.

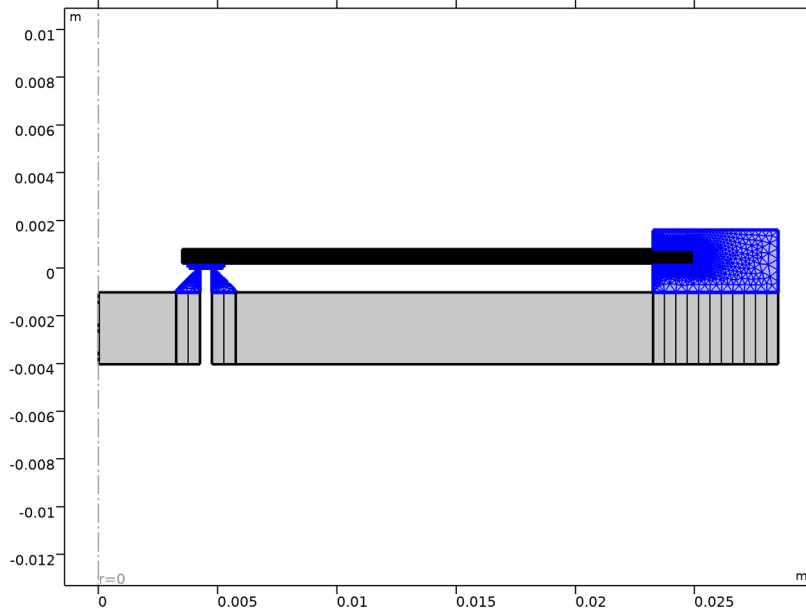

STUDY 1

Step 1: Stationary

1 In the **Model Builder** window, under **Study 1** click **Step 1: Stationary**.

2 In the **Settings** window for **Stationary**, click to expand the **Study Extensions** section.

3 Select the **Auxiliary sweep** checkbox.

4 Click  **Add**.



- 5 From the list in the **Parameter name** column, choose **V0 (Applied voltage)**, then specify values and unit as follows:

Parameter name	Parameter value list	Parameter unit
V0 (Applied voltage)	range(0, 5, 60)	V

For assistance in entering ranges of different kinds in the **Parameter value list** column, click the **Range** button to launch the **Range** dialog.

Solution 1 (sol1)

When modeling contact, both the contact pressure and the auxiliary pressure need to be manually scaled. It is good practice to modify the manual scaling of these variables to an appropriate value.

- 1 In the **Study** toolbar, click  **Show Default Solver**.
- 2 In the **Model Builder** window, expand the **Solution 1 (sol1)** node.
The contact pressure is expected to be of the order of MPa, so set the scales accordingly.
- 3 In the **Model Builder** window, expand the **Study 1 > Solver Configurations > Solution 1 (sol1) > Dependent Variables 1** node, then click **Auxiliary Pressure (comp1.solid.hmm1.pw)**.
- 4 In the **Settings** window for **Field**, locate the **Scaling** section.
- 5 In the **Scale** text field, type 1e6.
- 6 In the **Model Builder** window, under **Study 1 > Solver Configurations > Solution 1 (sol1) > Dependent Variables 1** click **Contact Pressure (comp1.solid.Tn_p1)**.
- 7 In the **Settings** window for **Field**, locate the **Scaling** section.
- 8 In the **Scale** text field, type 1e6.
- 9 In the **Model Builder** window, expand the **Study 1 > Solver Configurations > Solution 1 (sol1) > Stationary Solver 1** node.
Use the Automatic Newton solver for faster and more reliable convergence.
- 10 In the **Model Builder** window, expand the **Study 1 > Solver Configurations > Solution 1 (sol1) > Stationary Solver 1 > Segregated 1** node, then click **Merged Variables**.
- 11 In the **Settings** window for **Segregated Step**, click to expand the **Method and Termination** section.
- 12 From the **Nonlinear method** list, choose **Automatic (Newton)**.
- 13 In the **Study** toolbar, click  **Compute**.

RESULTS

Stress, 3D (solid)

Compare with [Figure 4](#).

Strain (ZZ component)

- 1 In the **Results** toolbar, click  **2D Plot Group**.
- 2 In the **Settings** window for **2D Plot Group**, type Strain (ZZ component) in the **Label** text field.
- 3 Locate the **Plot Settings** section. From the **Frame** list, choose **Spatial (r, phi, z)**.

Surface 1

- 1 Right-click **Strain (ZZ component)** and choose **Surface**.
- 2 In the **Settings** window for **Surface**, click **Replace Expression** in the upper-right corner of the **Expression** section. From the menu, choose **Component 1 (comp1) > Solid Mechanics > Strain > Strain tensor (material and geometry frames) > solid.eZZ - Strain tensor, ZZ-component**.
- 3 Locate the **Coloring and Style** section. From the **Color table transformation** list, choose **Reverse**.

Strain (ZZ component)

- 1 In the **Model Builder** window, click **Strain (ZZ component)**.
- 2 In the **Strain (ZZ component)** toolbar, click  **Plot**.
Zoom in on the contact region and compare the plot with [Figure 3](#).

Electric Field (Z component)

- 1 Right-click **Strain (ZZ component)** and choose **Duplicate**.
- 2 In the **Model Builder** window, click **Strain (ZZ component) 1**.
- 3 In the **Settings** window for **2D Plot Group**, type Electric Field (Z component) in the **Label** text field.

Surface 1

- 1 In the **Model Builder** window, click **Surface 1**.
- 2 In the **Settings** window for **Surface**, click to collapse the **Expression** section.
- 3 Click **Replace Expression** in the upper-right corner of the **Expression** section. From the menu, choose **Component 1 (comp1) > Electrostatics > Electric > Electric field (material and geometry frames) - V/m > es.EZ - Electric field, Z-component**.
- 4 In the **Electric Field (Z component)** toolbar, click  **Plot**.

Contact Pressure

- 1 In the **Results** toolbar, click  **ID Plot Group**.
- 2 In the **Settings** window for **ID Plot Group**, type Contact Pressure in the **Label** text field.
- 3 Locate the **Data** section. From the **Parameter selection (V0)** list, choose **Last**.

Line Graph 1

- 1 Right-click **Contact Pressure** and choose **Line Graph**.
- 2 Select Boundaries 60, 61, 65, 66, and 73 only.
- 3 In the **Settings** window for **Line Graph**, click **Replace Expression** in the upper-right corner of the **y-Axis Data** section. From the menu, choose **Component 1 (comp1) > Solid Mechanics > Contact > solid.Tn - Contact pressure - N/m²**.
- 4 In the **Contact Pressure** toolbar, click  **Plot**.



Appendix — Geometry Instructions

From the **File** menu, choose **New**.

NEW

In the **New** window, click  **Model Wizard**.

MODEL WIZARD

- 1 In the **Model Wizard** window, click  **2D Axisymmetric**.
- 2 Click  **Done**.

GLOBAL DEFINITIONS

Parameters 1

- 1 In the **Model Builder** window, under **Global Definitions** click **Parameters 1**.
- 2 In the **Settings** window for **Parameters**, locate the **Parameters** section.
- 3 In the table, enter the following settings:

Name	Expression	Value	Description
t0	0.05[mm]	5E-5 m	Piezoelectric layer thickness
ID	7[mm]	0.007 m	Disc actuator inner diameter
OD	50[mm]	0.05 m	Disc actuator outer diameter
n	12	12	Number of layers in actuator

Name	Expression	Value	Description
ts	0.2[mm]	2E-4 m	Thickness of seal
w0	0.5[mm]	5E-4 m	Through hole dimension
w1	ID/2	0.0035 m	Clamp region dimension
w2	ID/4	0.00175 m	Overall clamp dimension
h0	5*t0*n	0.003 m	Base thickness
deltaz	16[um]	1.6E-5 m	Contact offset at 0[V]

GEOMETRY I

Rectangle 1 (r1)

- 1 In the **Geometry** toolbar, click  **Rectangle**.
- 2 In the **Settings** window for **Rectangle**, locate the **Size and Shape** section.
- 3 In the **Width** text field, type $(OD - ID) / 2$.
- 4 In the **Height** text field, type t_0 .
- 5 Locate the **Position** section. In the **r** text field, type $ID/2$.
- 6 In the **z** text field, type t_s .
- 7 Click to expand the **Layers** section. Select the **Layers to the left** checkbox.
- 8 Clear the **Layers on bottom** checkbox.
- 9 In the table, enter the following settings:

Layer name	Thickness (m)
Layer 1	$0.5 * w_0$
Layer 2	$3 * w_0$

Array 1 (arr1)

- 1 In the **Geometry** toolbar, click  **Transforms** and choose **Array**.
- 2 In the **Settings** window for **Array**, locate the **Size** section.
- 3 In the **z size** text field, type n .
- 4 Locate the **Displacement** section. In the **z** text field, type t_0 .
- 5 Select the object **r1** only.

Rectangle 2 (r2)

- 1 In the **Geometry** toolbar, click  **Rectangle**.
- 2 In the **Settings** window for **Rectangle**, locate the **Size and Shape** section.
- 3 In the **Width** text field, type $3 * w_0$.

- 4 In the **Height** text field, type ts .
- 5 Locate the **Position** section. In the **r** text field, type $ID/2+0.5*w0$.

Fillet 1 (fil1)

- 1 In the **Geometry** toolbar, click  **Fillet**.
- 2 On the object **r2**, select Points 1 and 2 only.
- 3 In the **Settings** window for **Fillet**, locate the **Radius** section.
- 4 In the **Radius** text field, type $ts/3$.

Rectangle 3 (r3)

- 1 In the **Geometry** toolbar, click  **Rectangle**.
- 2 In the **Settings** window for **Rectangle**, locate the **Size and Shape** section.
- 3 In the **Width** text field, type $2*w0$.
- 4 In the **Height** text field, type $2*w0+h0$.
- 5 Locate the **Position** section. In the **r** text field, type $ID/2-0.5*w0$.
- 6 In the **z** text field, type $-2*w0-delta z-h0$.

Chamfer 1 (cha1)

- 1 In the **Geometry** toolbar, click  **Chamfer**.
- 2 On the object **r3**, select Point 4 only.
- 3 In the **Settings** window for **Chamfer**, locate the **Distance** section.
- 4 In the **Distance from vertex** text field, type $1.8*w0$.

Fillet 2 (fil2)

- 1 In the **Geometry** toolbar, click  **Fillet**.
- 2 On the object **cha1**, select Points 3 and 5 only.
- 3 In the **Settings** window for **Fillet**, locate the **Radius** section.
- 4 In the **Radius** text field, type $0.1*w0$.

Polygon 1 (pol1)

- 1 In the **Geometry** toolbar, click  **Polygon**.
- 2 In the **Settings** window for **Polygon**, locate the **Coordinates** section.
- 3 In the table, enter the following settings:

r (m)	z (m)
$ID/2+1.2*w0$	0
$ID/2+1.6*w0$	0

Mirror 1 (mir1)

- 1 In the **Geometry** toolbar, click  **Transforms** and choose **Mirror**.
- 2 Select the objects **fil2** and **pol1** only.
- 3 In the **Settings** window for **Mirror**, locate the **Input** section.
- 4 Select the **Keep input objects** checkbox.
- 5 Locate the **Point on Line of Reflection** section. In the **r** text field, type $ID/2+2*w0$.



Rectangle 4 (r4)

- 1 In the **Geometry** toolbar, click  **Rectangle**.
- 2 In the **Settings** window for **Rectangle**, locate the **Size and Shape** section.
- 3 In the **Width** text field, type $ID/2+1.5*w0$.
- 4 In the **Height** text field, type $h0$.
- 5 Locate the **Position** section. In the **z** text field, type $-2*w0-delta z-h0$.

Rectangle 5 (r5)

- 1 In the **Geometry** toolbar, click  **Rectangle**.
- 2 In the **Settings** window for **Rectangle**, locate the **Size and Shape** section.
- 3 In the **Width** text field, type $OD/2+w1-ID/2-2.5*w0$.
- 4 In the **Height** text field, type $h0$.
- 5 Locate the **Position** section. In the **r** text field, type $ID/2+2.5*w0$.
- 6 In the **z** text field, type $-2*w0-delta z-h0$.

Rectangle 6 (r6)

- 1 In the **Geometry** toolbar, click  **Rectangle**.
- 2 In the **Settings** window for **Rectangle**, locate the **Size and Shape** section.
- 3 In the **Width** text field, type $w2+w1$.
- 4 In the **Height** text field, type $h0+4*w0+n*t0+delta z$.
- 5 Locate the **Position** section. In the **r** text field, type $OD/2-w2$.
- 6 In the **z** text field, type $-2*w0-delta z-h0$.
- 7 Click  **Build Selected**.