



Current Density Distribution in a Solid Oxide Fuel Cell

Introduction

This example studies the current density distribution in a solid oxide fuel cell (SOFC). It includes the full coupling between the mass balances at the anode and cathode, the momentum balances in the gas channels, the gas flow in the porous electrodes, the balance of the ionic current carried by the oxide ion, and an electronic current balance.

Model Definition

An SOFC is constructed with two porous gas diffusion electrodes (GDEs) with an electrolyte sandwiched in the middle; see [Figure 1](#).

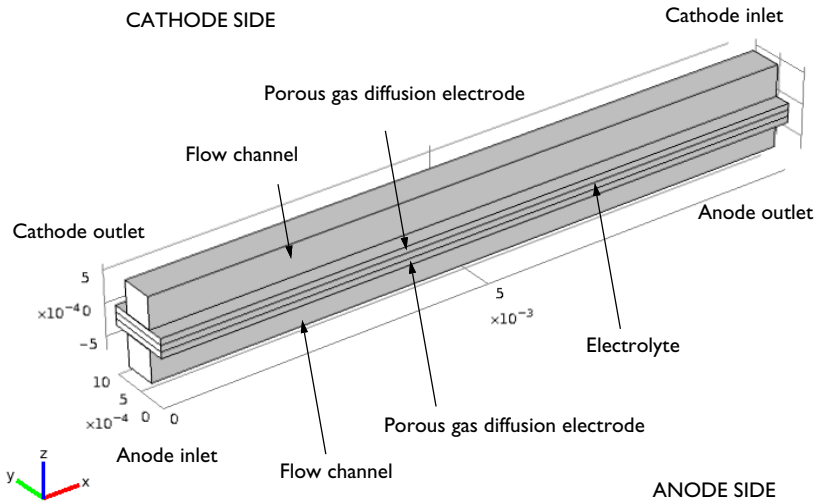
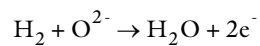

Figure 1: Geometry of the unit cell, with anode at the bottom and cathode at the top.

The fuel feed in the cathode and anode is counterflow, with hydrogen-rich anode gas entering from the left.

The electrochemical reactions in the cell are given below.

- Anode



- Cathode:

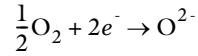

The model includes the following processes:

- Electronic charge balance (Ohm's law)
- Ionic charge balance (Ohm's law)
- Butler-Volmer charge transfer kinetics
- Mass balances in gas phase in both gas channels and GDEs (Maxwell-Stefan Diffusion and Convection)
- Flow distribution in gas channels (Navier-Stokes equations)
- Flow in the porous GDEs (Brinkman equations)

CHARGE BALANCES

The charge balance in the anode and cathode current feeders, the electrolyte and GDEs are solved for using a Hydrogen Fuel Cell interface.

The electrode and electrolyte current vectors are defined as (SI unit: A/m²)

$$\mathbf{i}_s = -\sigma_s \nabla \phi_s$$

and

$$\mathbf{i}_l = -\sigma_l \nabla \phi_l$$

respectively, where ϕ_s is the electrode phase potential (SI unit: V) and ϕ_l is the electrolyte phase potential (SI unit: V).

The electronic and ionic charge balances are then defined as

$$\nabla \cdot \mathbf{i}_s = -i_v$$

and

$$\nabla \cdot \mathbf{i}_l = i_v$$

respectively, where ϕ_s is the electrode phase potential (SI unit: V), ϕ_l is the electrolyte phase potential (SI unit: V) and i_v the volumetric current density (SI unit: A/m³), stemming from the charge transfer reactions, is defined as

$$i_v = A_v i_{loc}$$

where A_v (SI unit: m^2/m^3) is the specific surface area and i_{loc} is the local current density (SI unit: A/m^2).

Butler-Volmer charge transfer kinetics describe the charge transfer current density as a function of the overpotential and the partial pressures of the reacting gases.

The overpotential is defined as

$$\eta = \phi_s - \phi_l - E_{\text{eq}}$$

where, and E_{eq} the equilibrium potential (SI unit: V). The equilibrium potential depends on the partial pressures of the reacting gases and the temperature, and is calculated automatically by using the Nernst equation and the built-in thermodynamical database of the Hydrogen Fuel Cell interface.

At the anode, hydrogen is oxidized to form water, and the following charge transfer kinetics equation applies:

$$i_{\text{loc},a} = i_{0,a} \left(\frac{p_{\text{H}_2}}{p_{\text{H}_2,\text{ref}}} \right)^{\gamma_{\text{H}_2}} \left(\frac{p_{\text{H}_2\text{O}}}{p_{\text{H}_2\text{O},\text{ref}}} \right)^{\gamma_{\text{H}_2\text{O}}} \left(\exp\left(\frac{\alpha_a F}{RT} \eta\right) - \exp\left(\frac{\alpha_c F}{RT} \eta\right) \right)$$

Here $i_{0,a}$ is the anode exchange current density (SI unit: A/m^2) for the stated reference pressures, p_{H_2} is the partial pressure of hydrogen, $p_{\text{H}_2\text{O}}$ is the partial pressure of water, $p_{\text{H}_2,\text{ref}}$ and $p_{\text{H}_2\text{O},\text{ref}}$ are the reference pressures (1 atm). Furthermore, F is Faraday's constant (SI unit: C/mol), R the gas constant (SI unit: J/(mol·K)), T the temperature (SI unit: K), and η the overvoltage (SI unit: V). The exponents γ_{H_2} and $\gamma_{\text{H}_2\text{O}}$ (dimensionless) define the partial pressure dependencies of the reacting gases.

Correspondingly, for the cathode, the relation

$$i_{\text{loc},c} = i_{0,c} \left(\frac{p_{\text{O}_2}}{p_{\text{O}_2,\text{ref}}} \right)^{\gamma_{\text{O}_2}} \left(\exp\left(\frac{\alpha_a F}{RT} \eta\right) - \exp\left(\frac{\alpha_c F}{RT} \eta\right) \right)$$

is used, where $i_{0,c}$ is the cathode exchange current density (SI unit: A/m^2) at the reference pressure, and p_{O_2} is the partial pressure of oxygen. The values of the γ exponents and the α transfer coefficients for both reactions are taken from [Ref. 3](#).

At the anode's inlet boundary, the potential is grounded to a fixed potential of zero. At the cathode's inlet boundary, the potential is set to the cell voltage V_{cell} . In this model, you simulate the fuel cell for a range of cell voltages (ranging from around 1.0 V to 0.5 V) by using an auxiliary sweep.

MULTICOMPONENT MASS TRANSPORT AND GAS-FLOW EQUATIONS

SOFCs can be operated on many different fuels. This model describes a unit running on hydrogen and air. At the anode, a hydrogen gas is supplied as fuel and water is produced in the electrode reaction, implying that the gas consists of two components: hydrogen and water vapor. In the cathode, air (oxygen and nitrogen) is supplied and oxygen reacts.

The material transport is described by the Maxwell-Stefan's diffusion and convection equations, solved for by the Hydrogen Fuel Cell interface. The Free and Porous Media Flow, Brinkman interface is used for solving for the velocity field and pressure. The compressible Navier-Stokes equations govern the flow in the open channels and the Brinkman equations describe the flow velocity in the porous GDEs.

Couplings for the density, dynamic viscosity, velocity, pressure and net mass sources and sinks are made between the Hydrogen Fuel Cell and Free and Porous Media Flow, Brinkman interface by using Reacting Flow, H₂ Gas Phase and Reacting Flow, O₂ Gas Phase multiphysics nodes.

At the inlet, total flux conditions are used, corresponding to stoichiometry values of 2 for a current of 1.5 A/cm^2 . (This means that twice as much fuel and oxidant is fed into the cell than would be consumed at an average current density of 1.5 A/cm^2). At the outlets, condition convective outflow conditions are used.

Results and Discussion

Figure 2 shows the oxygen mole fraction in the cathode at a cell voltage 0.5 V. Significant gradients in the mole fraction is seen in the electrode domain which will be detrimental to the performance of the cell.

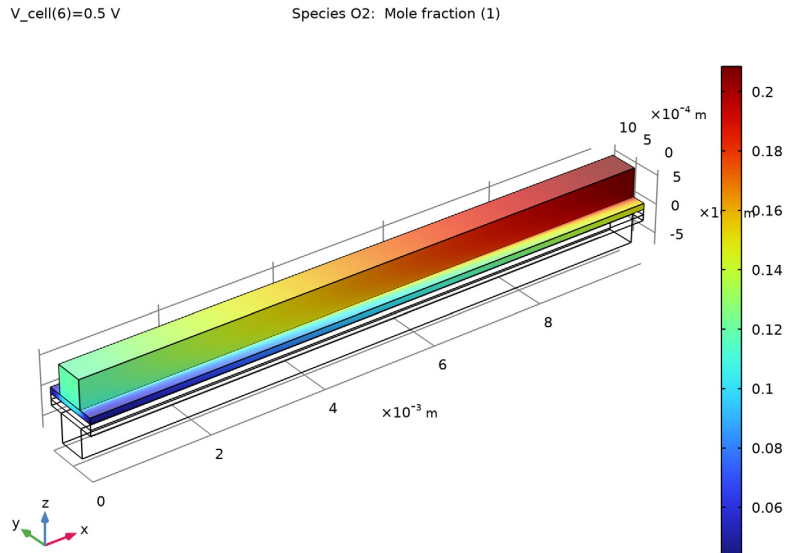

Figure 2: Oxygen mole fraction in the gas channel and in the gas diffusion cathode while operating at a cell voltage of 0.5 V. The inlet is to the right.

Figure 3 below shows the distribution of hydrogen. The mole fraction of hydrogen in the anode decreases along the channel, but in contrast to the oxygen mole fraction, only small gradients are seen in the y -direction within the electrode domain.

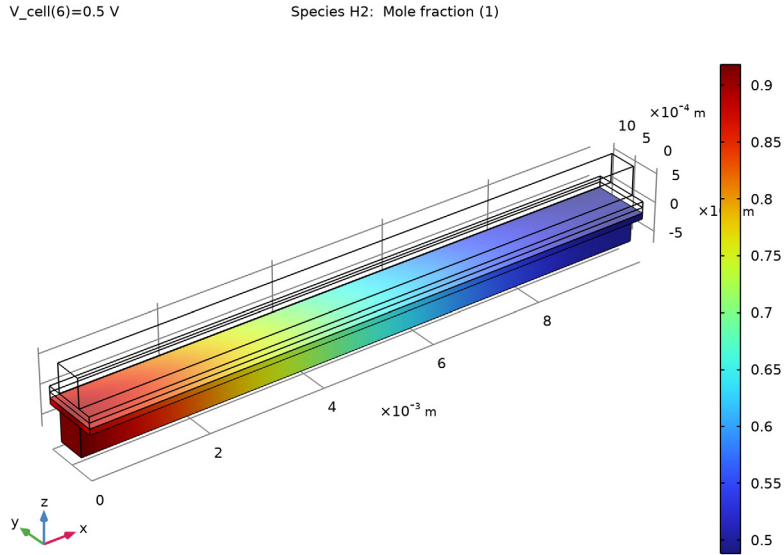

Figure 3: Hydrogen distribution in the anode at 0.5 V cell voltage. The inlet is to the left.

The non-uniform concentration distribution will contribute to the current density being less uniform in the GDEs. Figure 4 depicts the current density distribution at the cathode side of the ionic conductor.

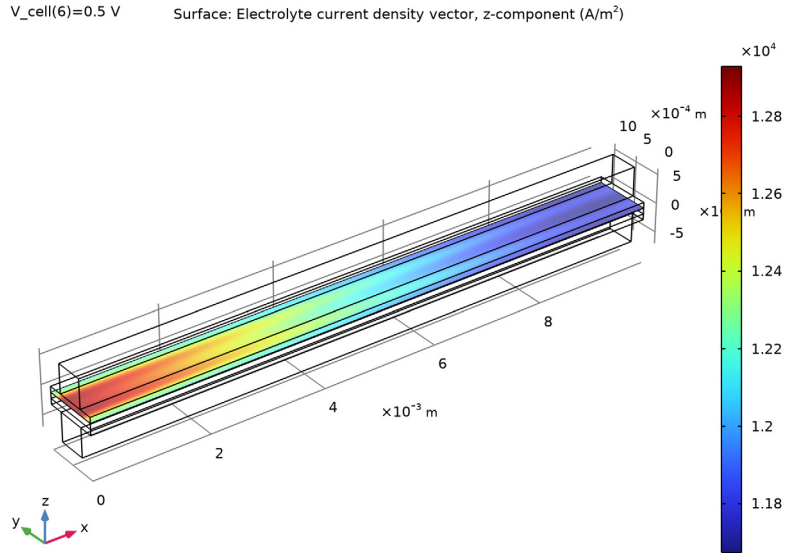

Figure 4: The electrolyte current density in the unit cell operating at 0.5 V.

One way to improve the operating conditions could be to increase the flow rate (the flow stoichiometry values).

Figure 5 shows the voltage as a function of the total current (polarization curve).

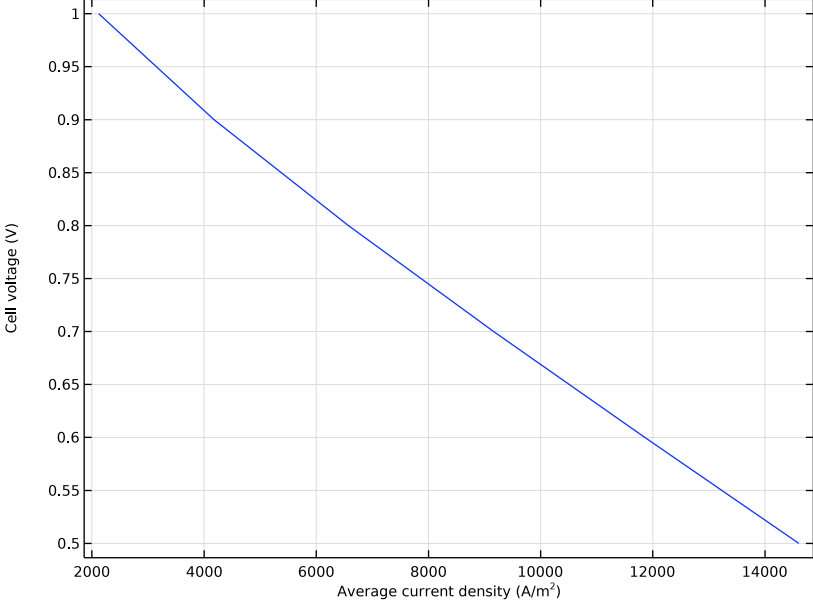

Figure 5: Polarization curve.

Figure 6 shows the power output as a function of the cell current density. For the highest current level, the power approaches a maximum value of about 7500 W/m² for the unit cell.

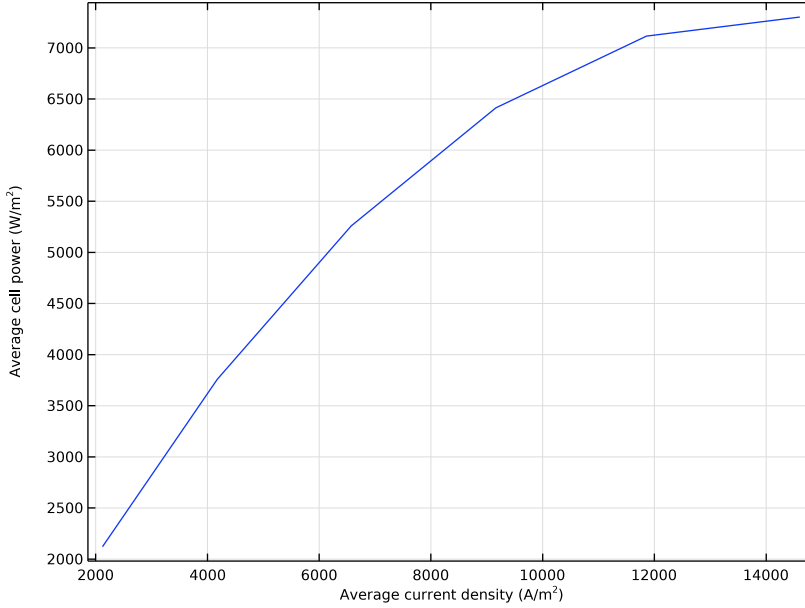

Figure 6: Power output as a function of cell voltage.

To attribute the voltage losses in the model to separate physical phenomena, we define a set of voltage loss (lumped overpotential) variables. The general approach to define the loss variables is to first compute the total loss in terms of electric power, and then to divide this number by the cell current.

The ohmic losses are computed by integrating the dot product of the gradient of the potential and the corresponding current vector, resulting in

$$E_l = \frac{\int -\nabla\phi_l \cdot \mathbf{i}_l \partial\Omega}{I_{\text{cell}}} \quad (1)$$

and

$$E_s = \frac{\int -\nabla\phi_s \cdot \mathbf{i}_s \partial\Omega}{I_{\text{cell}}} \quad (2)$$

for the electrolyte and electrode phases, respectively. In the above and following integral expressions, the integration is made for all applicable domains, and Ω is the volume element.

For the activation losses due to the charge transfer reactions in the electrodes, the loss of electric power is computed by integrating the product of the activation overpotential and the volumetric current density

$$E_{\text{act}} = \frac{\int \eta i_v \partial\Omega}{I_{\text{cell}}} \quad (3)$$

Figure 7 shows the lumped electrolyte and electrode overpotentials, as well as the anode and cathode activation losses. For this cell configuration, the electrolyte losses are the main contributor to the cell polarization.

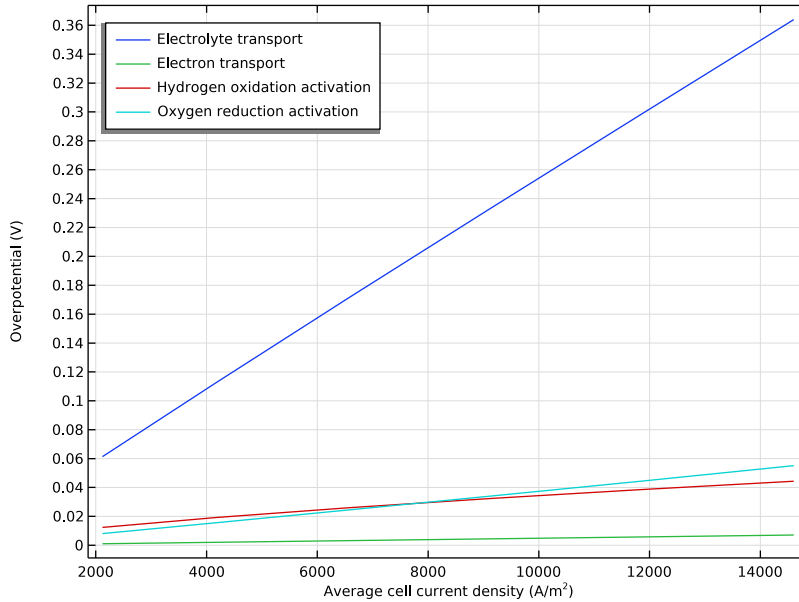

Figure 7: Lumped overvoltages.

References

1. J. Hartvigsen, S. Elangovan, and A. Khandkar, *Science and Technology of Zirconia V*, S.P.S. Badwal, M.J. Bannister, and R.H.J. Hannink, eds., p. 682, Technomic Publishing Company Inc., Lancaster, P.A., 1993.
2. R. Herbin, J.M. Fiard, and J.R. Ferguson, *First European Solid Oxide Fuel Cell Forum Proceedings*, U. Bossel, ed., p. 317, Lucerne, Switzerland, 1994.
3. M. García-Camprubí, S. Izquierdo, and N. Fueyo. *Renewable and Sustainable Energy Reviews* 33 (2014) 701-718

Application Library path: Fuel_Cell_and_Electrolyzer_Module/Fuel_Cells/sofc_unit_cell

Modeling Instructions

From the **File** menu, choose **New**.

NEW

In the **New** window, click  **Model Wizard**.

MODEL WIZARD

- 1 In the **Model Wizard** window, click  **3D**.
- 2 In the **Select Physics** tree, select **Electrochemistry > Hydrogen Fuel Cells > Solid Oxide (fc)**.
- 3 Click **Add**.
- 4 In the **Select Physics** tree, select **Fluid Flow > Porous Media and Subsurface Flow > Free and Porous Media Flow, Brinkman (fp)**.
- 5 Click **Add**.
- 6 In the **Velocity field (m/s)** text field, type `u_c`.
- 7 In the **Velocity field components** table, enter the following settings:

u_c

v_c

w_c

- 8 In the **Pressure (Pa)** text field, type `p_c`.

9 In the **Select Physics** tree, select **Fluid Flow > Porous Media and Subsurface Flow > Free and Porous Media Flow, Brinkman (fp)**.

10 Click **Add**.

11 In the **Velocity field (m/s)** text field, type `u_a`.

12 In the **Velocity field components** table, enter the following settings:

<code>u_a</code>
<code>v_a</code>
<code>w_a</code>

13 In the **Pressure (Pa)** text field, type `p_a`.

14 Click  **Study**.

15 In the **Select Study** tree, select **Preset Studies for Selected Physics Interfaces > Hydrogen Fuel Cell > Stationary with Initialization**.

16 Click  **Done**.

GLOBAL DEFINITIONS

Define the parameters using the text file provided.

Parameters 1

1 In the **Model Builder** window, under **Global Definitions** click **Parameters 1**.

2 In the **Settings** window for **Parameters**, locate the **Parameters** section.

3 Click  **Load from File**.

4 Browse to the model's Application Libraries folder and double-click the file `sofc_unit_cell_parameters.txt`.

GEOMETRY 1

Create the geometry by first defining the 2D cross section of the cell, then extrude it to create the 3D model geometry.

Work Plane 1 (wp1)

1 In the **Geometry** toolbar, click  **Work Plane**.



2 In the **Settings** window for **Work Plane**, locate the **Plane Definition** section.

3 From the **Plane** list, choose **yz-plane**.

Add rectangles as described below.

4 Click  **Go to Plane Geometry**.

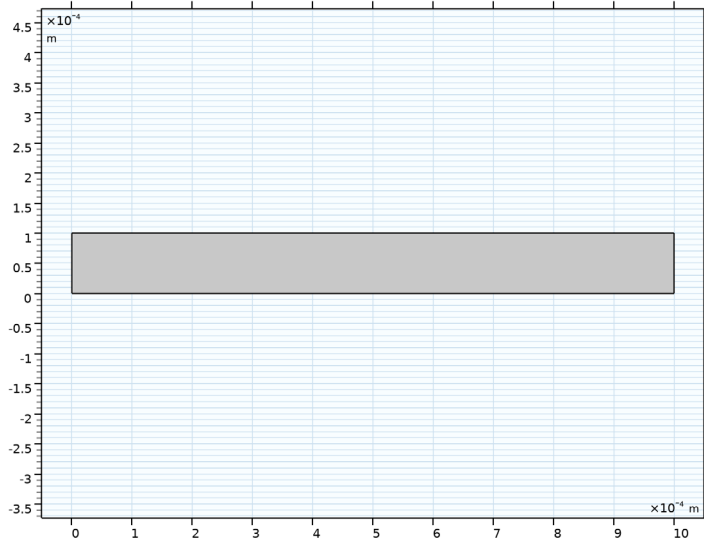

Work Plane 1 (wp1) > Rectangle 1 (r1)

- 1 In the **Work Plane** toolbar, click  **Rectangle**.
- 2 In the **Settings** window for **Rectangle**, locate the **Size and Shape** section.
- 3 In the **Width** text field, type $W_{\text{channel}}+W_{\text{rib}}$.
- 4 In the **Height** text field, type H_{gde} .
- 5 Click  **Build Selected**.





- 6 Click the  **Zoom Extents** button in the **Graphics** toolbar.

Work Plane 1 (wp1) > Rectangle 2 (r2)



- 1 In the **Work Plane** toolbar, click  **Rectangle**.
- 2 In the **Settings** window for **Rectangle**, locate the **Size and Shape** section.
- 3 In the **Width** text field, type $W_{\text{channel}}+W_{\text{rib}}$.
- 4 In the **Height** text field, type $H_{\text{electrolyte}}$.
- 5 Locate the **Position** section. In the **yw** text field, type $-H_{\text{electrolyte}}$.
- 6 Click  **Build Selected**.

Work Plane 1 (wp1) > Rectangle 3 (r3)

- 1 In the **Work Plane** toolbar, click  **Rectangle**.
- 2 In the **Settings** window for **Rectangle**, locate the **Size and Shape** section.
- 3 In the **Width** text field, type $W_{\text{channel}}+W_{\text{rib}}$.

- 4 In the **Height** text field, type H_gde.
- 5 Locate the **Position** section. In the **yw** text field, type -H_electrolyte-H_gde.
- 6 Click  **Build Selected**.

Work Plane 1 (wp1) > Rectangle 4 (r4)

- 1 In the **Work Plane** toolbar, click  **Rectangle**.
- 2 In the **Settings** window for **Rectangle**, locate the **Size and Shape** section.
- 3 In the **Width** text field, type W_channel.
- 4 In the **Height** text field, type H_channel.
- 5 Locate the **Position** section. In the **xw** text field, type W_rib/2.
- 6 In the **yw** text field, type H_gde.
- 7 Click  **Build Selected**.

Work Plane 1 (wp1) > Rectangle 5 (r5)

- 1 In the **Work Plane** toolbar, click  **Rectangle**.
- 2 In the **Settings** window for **Rectangle**, locate the **Size and Shape** section.
- 3 In the **Width** text field, type W_channel.
- 4 In the **Height** text field, type H_channel.
- 5 Locate the **Position** section. In the **xw** text field, type W_rib/2.
- 6 In the **yw** text field, type -H_gde-H_electrolyte-H_channel.

7 Click  **Build Selected.**

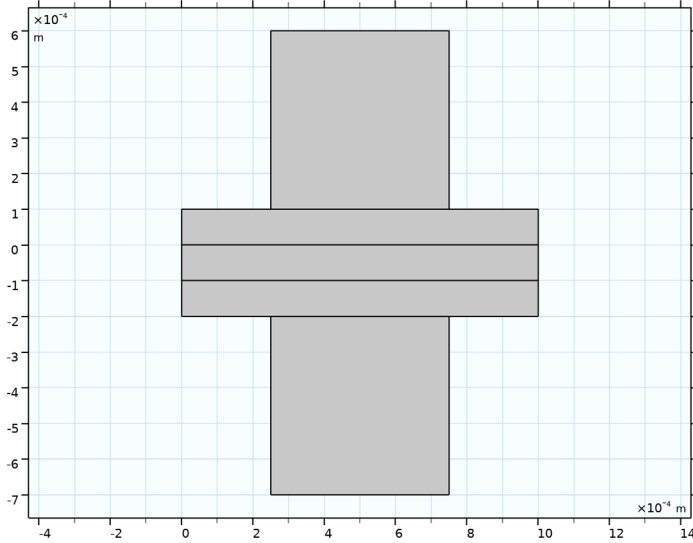

8 Click the  **Zoom Extents** button in the **Graphics** toolbar.

Extrude 1 (ext1)

1 In the **Model Builder** window, under **Component 1 (comp1) > Geometry 1** right-click **Work Plane 1 (wp1)** and choose **Extrude**.

2 In the **Settings** window for **Extrude**, locate the **Distances** section.

3 In the table, enter the following settings:

Distances (m)
L

4 Click  **Build All Objects.**

- 5 Click the  **Zoom Extents** button in the **Graphics** toolbar.

The model geometry is now complete, and it should look like that in the figure below.

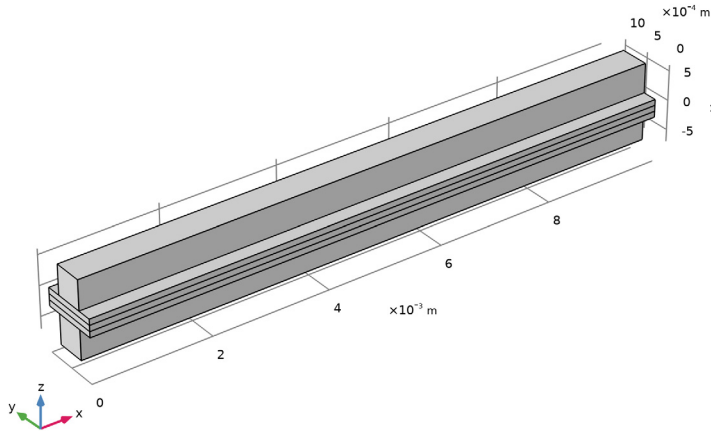

DEFINITIONS

Now make a number of selections to facilitate choosing different parts of the geometry when setting up the model.

Anode Flow Channel

- 1 In the **Definitions** toolbar, click  **Explicit**.
- 2 In the **Settings** window for **Explicit**, type Anode Flow Channel in the **Label** text field.
- 3 Select Domain 4 only.

Anode Gas Diffusion Electrode

- 1 In the **Definitions** toolbar, click  **Explicit**.
- 2 In the **Settings** window for **Explicit**, type Anode Gas Diffusion Electrode in the **Label** text field.
- 3 Select Domain 1 only.

Cathode Gas Diffusion Electrode

- 1 In the **Definitions** toolbar, click  **Explicit**.
- 2 In the **Settings** window for **Explicit**, type Cathode Gas Diffusion Electrode in the **Label** text field.

3 Select Domain 3 only.



Cathode Flow Channel

- 1 In the **Definitions** toolbar, click  **Explicit**.
- 2 In the **Settings** window for **Explicit**, type Cathode Flow Channel in the **Label** text field.
- 3 Select Domain 5 only.



Membrane

- 1 In the **Definitions** toolbar, click  **Explicit**.
- 2 In the **Settings** window for **Explicit**, type Membrane in the **Label** text field.
- 3 Select Domain 2 only.

Anode Flow Domains



- 1 In the **Definitions** toolbar, click  **Union**.
- 2 In the **Settings** window for **Union**, type Anode Flow Domains in the **Label** text field.
- 3 Locate the **Input Entities** section. Under **Selections to add**, click  **Add**.
- 4 In the **Add** dialog, in the **Selections to add** list, choose **Anode Flow Channel** and **Anode Gas Diffusion Electrode**.
- 5 Click **OK**.

Cathode Flow Domains

- 1 In the **Definitions** toolbar, click  **Union**.
- 2 In the **Settings** window for **Union**, type Cathode Flow Domains in the **Label** text field.
- 3 Locate the **Input Entities** section. Under **Selections to add**, click  **Add**.
- 4 In the **Add** dialog, in the **Selections to add** list, choose **Cathode Gas Diffusion Electrode** and **Cathode Flow Channel**.
- 5 Click **OK**.

Add the material properties for the electrolyte from the Material Library.

ADD MATERIAL

- 1 In the **Materials** toolbar, click  **Add Material** to open the **Add Material** window.
- 2 Go to the **Add Material** window.
- 3 In the tree, select **Fuel Cell and Electrolyzer > Solid Oxides > Yttria-Stabilized Zirconia, 8YSZ, (ZrO2)0.92-(Y2O3)0.08**.
- 4 Right-click and choose **Add to Component 1 (comp1)**.
- 5 In the **Materials** toolbar, click  **Add Material** to close the **Add Material** window.

HYDROGEN FUEL CELL (FC)

Set up the current distribution and mass transport model in the fuel cell interface. In this model we will use the default gas species, which are hydrogen and water on the anode side, and oxygen and nitrogen on the cathode side.

Add a membrane node, and flow channel nodes for the anode and cathode sides, and set the geometry selection. No additional settings are required for these nodes.

Membrane 1

- 1 In the **Physics** toolbar, click  **Domains** and choose **Membrane**.
- 2 In the **Settings** window for **Membrane**, locate the **Domain Selection** section.
- 3 From the **Selection** list, choose **Membrane**.

H2 Gas Flow Channel 1

- 1 In the **Physics** toolbar, click  **Domains** and choose **H2 Gas Flow Channel**.
- 2 In the **Settings** window for **H2 Gas Flow Channel**, locate the **Domain Selection** section.
- 3 From the **Selection** list, choose **Anode Flow Channel**.

O2 Gas Flow Channel 1

- 1 In the **Physics** toolbar, click  **Domains** and choose **O2 Gas Flow Channel**.
- 2 In the **Settings** window for **O2 Gas Flow Channel**, locate the **Domain Selection** section.
- 3 From the **Selection** list, choose **Cathode Flow Channel**.

H2 Gas Diffusion Electrode 1

Now add and set up the anode.

- 1 In the **Physics** toolbar, click  **Domains** and choose **H2 Gas Diffusion Electrode**.
- 2 In the **Settings** window for **H2 Gas Diffusion Electrode**, locate the **Domain Selection** section.
- 3 From the **Selection** list, choose **Anode Gas Diffusion Electrode**.
- 4 Locate the **Electrode Charge Transport** section. In the σ_s text field, type `kseff_a`.
- 5 Locate the **Effective Electrolyte Charge Transport** section. From the **Effective conductivity correction** list, choose **User defined**. In the f_1 text field, type `f1_a`.
- 6 Locate the **Gas Transport** section. In the ϵ_g text field, type `e_por`.
Include pore-wall interactions by Knudsen diffusion in the gas diffusion electrodes. This will reduce the mass transport properties of the electrodes by adding additional friction between the gas molecules and the pore walls.
- 7 Select the **Include pore-wall interaction** checkbox.

8 In the d_{pore} text field, type d_pore.

H2 Gas Diffusion Electrode Reaction 1

The details of electrode kinetics are set in the child node. Note that the reference equilibrium potential is calculated automatically when the default **Built in** option is used.

- 1 In the **Model Builder** window, click **H2 Gas Diffusion Electrode Reaction 1**.
- 2 In the **Settings** window for **H2 Gas Diffusion Electrode Reaction**, locate the **Electrode Kinetics** section.
- 3 In the $i_{0,\text{ref}}(T)$ text field, type i0_a.
- 4 From the **Exchange current density type** list, choose **Lumped multistep**.
- 5 In the γ_{H_2} text field, type gamma_H2.
- 6 In the $\gamma_{\text{H}_2\text{O}}$ text field, type gamma_H2O.
- 7 In the α_a text field, type alpha_a_H2.
- 8 In the α_c text field, type alpha_c_H2.
- 9 Locate the **Active Specific Surface Area** section. In the a_v text field, type Sa_a.

O2 Gas Diffusion Electrode 1

Add and set up the cathode in a similar way.

- 1 In the **Physics** toolbar, click  **Domains** and choose **O2 Gas Diffusion Electrode**.
- 2 In the **Settings** window for **O2 Gas Diffusion Electrode**, locate the **Domain Selection** section.
- 3 From the **Selection** list, choose **Cathode Gas Diffusion Electrode**.
- 4 Locate the **Electrode Charge Transport** section. In the σ_s text field, type kseff_c.
- 5 Locate the **Effective Electrolyte Charge Transport** section. From the **Effective conductivity correction** list, choose **User defined**. In the f_1 text field, type f1_c.
- 6 Locate the **Gas Transport** section. In the ϵ_g text field, type e_por.
- 7 Select the **Include pore-wall interaction** checkbox.
- 8 In the d_{pore} text field, type d_pore.

O2 Gas Diffusion Electrode Reaction 1

- 1 In the **Model Builder** window, click **O2 Gas Diffusion Electrode Reaction 1**.
- 2 In the **Settings** window for **O2 Gas Diffusion Electrode Reaction**, locate the **Electrode Kinetics** section.
- 3 In the $i_{0,\text{ref}}(T)$ text field, type i0_c.
- 4 From the **Exchange current density type** list, choose **Lumped multistep**.

- 5 In the γ_{O_2} text field, type gamma_02.
- 6 In the α_a text field, type alpha_a_02.
- 7 In the α_c text field, type alpha_c_02.
- 8 Locate the **Active Specific Surface Area** section. In the a_v text field, type Sa_c.

Electronic Conducting Phase I

Next, set up the boundary conditions and initial values on the phase nodes.

In the **Model Builder** window, under **Component 1 (comp1) > Hydrogen Fuel Cell (fc)** click **Electronic Conducting Phase I**.

Electric Ground I

- 1 In the **Physics** toolbar, click  **Attributes** and choose **Electric Ground**.
- 2 Select Boundaries 3 and 20 only.

Electronic Conducting Phase I

In the **Model Builder** window, click **Electronic Conducting Phase I**.

Electric Potential I

- 1 In the **Physics** toolbar, click  **Attributes** and choose **Electric Potential**.
- 2 Select Boundaries 10 and 22 only.
- 3 In the **Settings** window for **Electric Potential**, locate the **Electric Potential** section.
- 4 In the $\phi_{s,bnd}$ text field, type V_cell.

Initial Values I

- 1 In the **Model Builder** window, expand the **Component 1 (comp1) > Hydrogen Fuel Cell (fc) > H2 Gas Phase I** node, then click **Initial Values I**.
- 2 In the **Settings** window for **Initial Values**, locate the **Initial Composition** section.
- 3 In the x_{0,H_2O} text field, type 0.1.

H2 Gas Phase I

In the **Model Builder** window, click **H2 Gas Phase I**.

H2 Inlet I

- 1 In the **Physics** toolbar, click  **Attributes** and choose **H2 Inlet**.
- 2 Select Boundary 11 only.

You can also create a named selection from within a feature node as follows:



- 3 In the **Settings** window for **H2 Inlet**, locate the **Boundary Selection** section.
- 4 Click  **Create Selection**.

- 5 In the **Create Selection** dialog, type Anode Inlet in the **Selection name** text field.
- 6 Click **OK**.
- 7 In the **Settings** window for **H2 Inlet**, locate the **Mixture Specification** section.
- 8 From the list, choose **Mass flow rates**.
Keep the default value of 0 [kg/s] for the flow rate of water. This means the incoming flow consists of pure hydrogen. The total flow rate will be specified later in the **Free and Porous Media Flow** interface.

H2 Gas Phase I

In the **Model Builder** window, click **H2 Gas Phase I**.

H2 Outlet I

- 1 In the **Physics** toolbar, click  **Attributes** and choose **H2 Outlet**.
- 2 Select Boundary 29 only.
- 3 In the **Settings** window for **H2 Outlet**, locate the **Boundary Selection** section.
- 4 Click  **Create Selection**.
- 5 In the **Create Selection** dialog, type Anode Outlet in the **Selection name** text field.
- 6 Click **OK**.



Initial Values I

- 1 In the **Model Builder** window, expand the **Component 1 (comp1) > Hydrogen Fuel Cell (fc) > O2 Gas Phase I** node, then click **Initial Values I**.
- 2 In the **Settings** window for **Initial Values**, locate the **Initial Composition** section.
- 3 In the x_{0,N_2} text field, type $x_{N_2_in}$.

O2 Gas Phase I

In the **Model Builder** window, click **O2 Gas Phase I**.

O2 Inlet I

- 1 In the **Physics** toolbar, click  **Attributes** and choose **O2 Inlet**.
- 2 Select Boundary 30 only.
- 3 In the **Settings** window for **O2 Inlet**, locate the **Boundary Selection** section.
- 4 Click  **Create Selection**.
- 5 In the **Create Selection** dialog, type Cathode Inlet in the **Selection name** text field.
- 6 Click **OK**.
- 7 In the **Settings** window for **O2 Inlet**, locate the **Mixture Specification** section.

8 From the list, choose **Mass flow rates**.

9 In the J_{0,N_2} text field, type m_{N_2} .

10 In the ω_{0,bnd,N_2} text field, type 0.8.

O2 Gas Phase 1

In the **Model Builder** window, click **O2 Gas Phase 1**.

O2 Outlet 1

1 In the **Physics** toolbar, click  **Attributes** and choose **O2 Outlet**.

2 Select Boundary 15 only.

3 In the **Settings** window for **O2 Outlet**, locate the **Boundary Selection** section.

4 Click  **Create Selection**.

5 In the **Create Selection** dialog, type Cathode Outlet in the **Selection name** text field.

6 Click **OK**.

FREE AND POROUS MEDIA FLOW - CATHODE

Now set up the convective flow on the cathode side.

1 In the **Model Builder** window, under **Component 1 (comp1)** click **Free and Porous Media Flow, Brinkman (fp)**.

2 In the **Settings** window for **Free and Porous Media Flow, Brinkman**, type Free and Porous Media Flow - Cathode in the **Label** text field.

3 Locate the **Domain Selection** section. From the **Selection** list, choose **Cathode Flow Domains**.

4 In the **Model Builder** window, under **Component 1 (comp1)** click **Free and Porous Media Flow - Cathode (fp)**.

5 Locate the **Physical Model** section. From the **Compressibility** list, choose **Compressible flow (Ma<0.3)**.

6 In the p_{ref} text field, type p_{atm} .

Porous Medium 1

Set up the properties of the porous gas diffusion electrode, followed by the boundary conditions. Note that the density and viscosity of the gas mixture are calculated by the **Hydrogen Fuel Cell** interface and will be defined automatically after adding the **Multiphysics** coupling nodes.

1 In the **Physics** toolbar, click  **Domains** and choose **Porous Medium**.

2 In the **Settings** window for **Porous Medium**, locate the **Domain Selection** section.

3 From the **Selection** list, choose **Cathode Gas Diffusion Electrode**.

Porous Matrix 1

- 1 In the **Model Builder** window, click **Porous Matrix 1**.
- 2 In the **Settings** window for **Porous Matrix**, locate the **Matrix Properties** section.
- 3 From the ε_p list, choose **User defined**. In the associated text field, type `e_por`.
- 4 From the κ list, choose **User defined**. In the associated text field, type `perm_c`.

Inlet 1

- 1 In the **Physics** toolbar, click  **Boundaries** and choose **Inlet**.
- 2 In the **Settings** window for **Inlet**, locate the **Boundary Selection** section.
- 3 From the **Selection** list, choose **Cathode Inlet**.
- 4 Locate the **Boundary Condition** section. From the list, choose **Mass flow**.
- 5 Locate the **Mass Flow** section. In the m text field, type `m_H2`.
- 6 In the m text field, type `m_O2+m_N2`.

Outlet 1

- 1 In the **Physics** toolbar, click  **Boundaries** and choose **Outlet**.
- 2 In the **Settings** window for **Outlet**, locate the **Boundary Selection** section.
- 3 From the **Selection** list, choose **Cathode Outlet**.
- 4 Locate the **Pressure Conditions** section. Select the **Normal flow** checkbox.

FREE AND POROUS MEDIA FLOW - ANODE

Set up the fluid flow model on the anode side in the same way.

- 1 In the **Model Builder** window, under **Component 1 (comp1)** click **Free and Porous Media Flow, Brinkman 2 (fp2)**.
- 2 In the **Settings** window for **Free and Porous Media Flow, Brinkman**, type `Free and Porous Media Flow - Anode` in the **Label** text field.
- 3 Locate the **Domain Selection** section. From the **Selection** list, choose **Anode Flow Domains**.
- 4 In the **Model Builder** window, under **Component 1 (comp1)** click **Free and Porous Media Flow - Anode (fp2)**.
- 5 Locate the **Physical Model** section. From the **Compressibility** list, choose **Compressible flow (Ma<0.3)**.
- 6 In the p_{ref} text field, type `p_atm`.

Porous Medium 1

- 1 In the **Physics** toolbar, click  **Domains** and choose **Porous Medium**.
- 2 In the **Settings** window for **Porous Medium**, locate the **Domain Selection** section.
- 3 From the **Selection** list, choose **Anode Gas Diffusion Electrode**.

Porous Matrix 1

- 1 In the **Model Builder** window, click **Porous Matrix 1**.
- 2 In the **Settings** window for **Porous Matrix**, locate the **Matrix Properties** section.
- 3 From the ϵ_p list, choose **User defined**. In the associated text field, type e_por.
- 4 From the κ list, choose **User defined**. In the associated text field, type perm_a.

Inlet 1

- 1 In the **Physics** toolbar, click  **Boundaries** and choose **Inlet**.
- 2 In the **Settings** window for **Inlet**, locate the **Boundary Selection** section.
- 3 From the **Selection** list, choose **Anode Inlet**.
- 4 Locate the **Boundary Condition** section. From the list, choose **Mass flow**.
- 5 Locate the **Mass Flow** section. In the m text field, type m_H2.

Outlet 1

- 1 In the **Physics** toolbar, click  **Boundaries** and choose **Outlet**.
- 2 In the **Settings** window for **Outlet**, locate the **Boundary Selection** section.
- 3 From the **Selection** list, choose **Anode Outlet**.
- 4 Locate the **Pressure Conditions** section. Select the **Normal flow** checkbox.

MULTIPHYSICS

Next, couple the flow interfaces to the fuel cell interface by using the reacting flow multiphysics coupling nodes.

Reacting Flow, H2 Gas Phase 1 (rfh1)

- 1 In the **Physics** toolbar, click  **Multiphysics Couplings** and choose **Domain > Reacting Flow, H2 Gas Phase**.
- 2 In the **Settings** window for **Reacting Flow, H2 Gas Phase**, locate the **Coupled Interfaces** section.
- 3 From the **Fluid flow** list, choose **Free and Porous Media Flow - Anode (fp2)**.

Reacting Flow, O2 Gas Phase I (rfo1)

In the **Physics** toolbar, click  **Multiphysics Couplings** and choose **Domain > Reacting Flow, O2 Gas Phase**.

GLOBAL DEFINITIONS

Default Model Inputs

Default Model Inputs node can be used to set the **Temperature** for the entire model. This node may be accessed by multiple physics nodes.

- 1 In the **Model Builder** window, under **Global Definitions** click **Default Model Inputs**.
- 2 In the **Settings** window for **Default Model Inputs**, locate the **Browse Model Inputs** section.
- 3 In the tree, select **General > Temperature (K) - minput.T**.
- 4 Find the **Expression for remaining selection** subsection. In the **Temperature** text field, type T.

MESH I

The physics settings for the model is now complete. A mapped mesh, swept in the channel direction, is suitable for this geometry. Control the size in the y direction by using an individual **Edge** node.

Edge I

- 1 In the **Mesh** toolbar, click  **More Generators** and choose **Edge**.
- 2 Select Edges 2, 10, 15, 18, 24, and 27 only.

Size I

- 1 Right-click **Edge I** and choose **Size**.
- 2 In the **Settings** window for **Size**, locate the **Element Size** section.
- 3 Click the **Custom** button.
- 4 Locate the **Element Size Parameters** section.
- 5 Select the **Maximum element size** checkbox. In the associated text field, type $w_{\text{channel}}/8$.
- 6 Click  **Build Selected**.

Mapped I

- 1 In the **Mesh** toolbar, click  **More Generators** and choose **Mapped**.
- 2 Select Boundaries 1, 4, 7, 11, and 15 only.

Distribution 1

- 1 Right-click **Mapped 1** and choose **Distribution**.
- 2 Select Edges 12, 17, 22, and 26 only.
- 3 In the **Settings** window for **Distribution**, locate the **Distribution** section.
- 4 From the **Distribution type** list, choose **Predefined**.
- 5 In the **Number of elements** text field, type 10.
- 6 In the **Element ratio** text field, type 3.
- 7 Select the **Symmetric distribution** checkbox.

Distribution 2

- 1 In the **Model Builder** window, right-click **Mapped 1** and choose **Distribution**.
- 2 Select Edges 7 and 34 only.
- 3 In the **Settings** window for **Distribution**, locate the **Distribution** section.
- 4 From the **Distribution type** list, choose **Predefined**.
- 5 In the **Number of elements** text field, type 8.
- 6 In the **Element ratio** text field, type 3.

Distribution 3

- 1 Right-click **Distribution 2** and choose **Duplicate**.
- 2 In the **Settings** window for **Distribution**, locate the **Edge Selection** section.
- 3 Click  **Clear Selection**.
- 4 Select Edges 1 and 30 only.
- 5 Locate the **Distribution** section. Select the **Reverse direction** checkbox.

Distribution 4

- 1 In the **Model Builder** window, right-click **Mapped 1** and choose **Distribution**.
- 2 Select Edges 4 and 32 only.
- 3 In the **Settings** window for **Distribution**, locate the **Distribution** section.
- 4 In the **Number of elements** text field, type 3.

Mapped 1

Right-click **Mapped 1** and choose **Build Selected**.

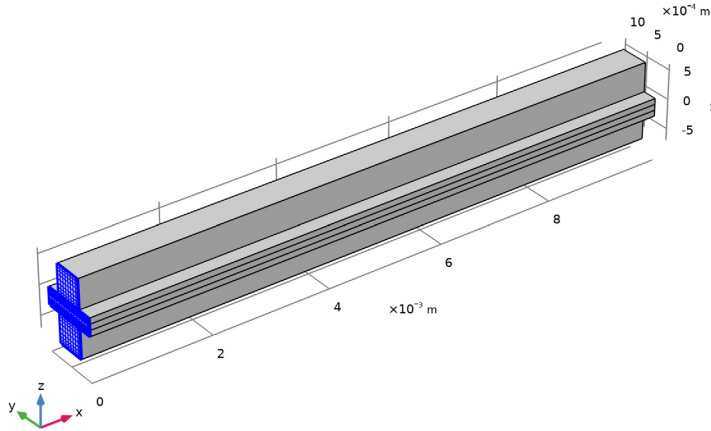

Swept 1

In the **Mesh** toolbar, click  **Swept**.

Size 1

- 1 Right-click **Swept 1** and choose **Size**.
- 2 In the **Settings** window for **Size**, locate the **Element Size** section.
- 3 Click the **Custom** button.
- 4 Locate the **Element Size Parameters** section.
- 5 Select the **Maximum element size** checkbox. In the associated text field, type `W_channel1`.
- 6 Click  **Build All**.

7 Click the  **Zoom Extents** button in the **Graphics** toolbar.

The meshing is now complete, and it should look like that in the figure below.

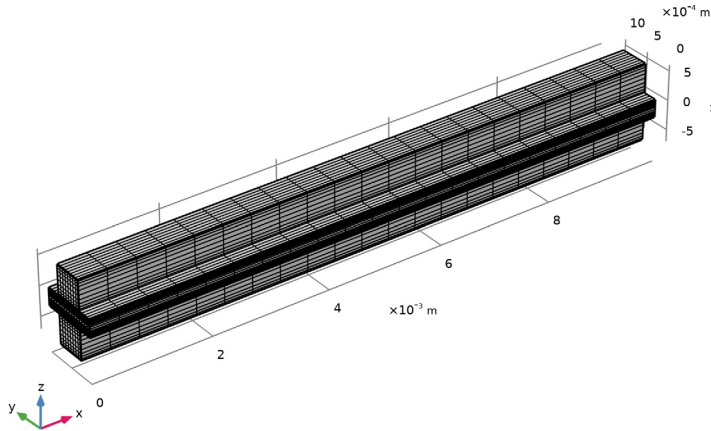

DEFINITIONS

Before solving, add a probe for the average cell current density, it will be plotted during the solver process.

Cell Current Density Probe

- 1 In the **Definitions** toolbar, click  **Probes** and choose **Domain Probe**.
- 2 In the **Settings** window for **Domain Probe**, type Cell Current Density Probe in the **Label** text field.
- 3 In the **Variable name** text field, type I_{cell} .
- 4 Locate the **Source Selection** section. From the **Selection** list, choose **Anode Gas Diffusion Electrode**.
- 5 Click **Replace Expression** in the upper-right corner of the **Expression** section. From the menu, choose **Component I (compI) > Hydrogen Fuel Cell > Electrode kinetics > fc.ivtot - Electrode reaction source - A/m³**.
- 6 Locate the **Expression** section. In the **Expression** text field, type $fc.ivtot * H_{gde}$.
- 7 Select the **Description** checkbox. In the associated text field, type Average cell current density.

STUDY 1

The problem is now ready for solving. Firstly, solve for a current distribution initialization for the fuel cell interface, followed by flow initialization in two subsequent study steps. Finally, solve the entire model including the multiphysics couplings in the final step, along with an auxiliary sweep to solve for a range of different cell polarization voltages.

Step 1: Current Distribution Initialization

- 1 In the **Model Builder** window, under **Study 1** click **Step 1: Current Distribution Initialization**.
- 2 In the **Settings** window for **Current Distribution Initialization**, locate the **Physics and Variables Selection** section.
- 3 In the **Solve for** column of the table, under **Component 1 (comp1) > Multiphysics**, clear the checkboxes for **Reacting Flow, H2 Gas Phase 1 (rfh1)** and **Reacting Flow, O2 Gas Phase 1 (rfo1)**.



Step 2: Stationary

- 1 In the **Model Builder** window, click **Step 2: Stationary**.
- 2 In the **Settings** window for **Stationary**, locate the **Physics and Variables Selection** section.
- 3 In the **Solve for** column of the table, under **Component 1 (comp1)**, clear the checkboxes for **Hydrogen Fuel Cell (fc)** and **Free and Porous Media Flow - Anode (fp2)**.
- 4 In the **Solve for** column of the table, under **Component 1 (comp1) > Multiphysics**, clear the checkboxes for **Reacting Flow, H2 Gas Phase 1 (rfh1)** and **Reacting Flow, O2 Gas Phase 1 (rfo1)**.

Step 3: Stationary 2

- 1 In the **Study** toolbar, click  **Study Steps** and choose **Stationary > Stationary**.
- 2 In the **Settings** window for **Stationary**, locate the **Physics and Variables Selection** section.
- 3 In the **Solve for** column of the table, under **Component 1 (comp1)**, clear the checkboxes for **Hydrogen Fuel Cell (fc)** and **Free and Porous Media Flow - Cathode (fp)**.
- 4 In the **Solve for** column of the table, under **Component 1 (comp1) > Multiphysics**, clear the checkboxes for **Reacting Flow, H2 Gas Phase 1 (rfh1)** and **Reacting Flow, O2 Gas Phase 1 (rfo1)**.

Step 4: Stationary 3



- 1 In the **Study** toolbar, click  **Study Steps** and choose **Stationary > Stationary**.
- 2 In the **Settings** window for **Stationary**, click to expand the **Study Extensions** section.
- 3 Select the **Auxiliary sweep** checkbox.
- 4 Click  **Add**.

5 In the table, enter the following settings:

Parameter name	Parameter value list	Parameter unit
V_cell (Cell voltage)	range (1, -0.1, 0.5)	V

Solution 1 (sol1)

The final study step of the solver sequence, solving for all of the physics interfaces, uses a segregated solver by default in order to save memory. This is however not needed for this fairly small model. To speed up the computation, replace the default segregated solver with a fully coupled solver as follows:

- 1 In the **Study** toolbar, click  **Show Default Solver**.
- 2 In the **Model Builder** window, expand the **Solution 1 (sol1)** node.
- 3 In the **Model Builder** window, expand the **Study 1 > Solver Configurations > Solution 1 (sol1) > Stationary Solver 4** node.
- 4 Right-click **Study 1 > Solver Configurations > Solution 1 (sol1) > Stationary Solver 4** and choose **Fully Coupled**.
- 5 In the **Study** toolbar, click  **Compute**.

The computation takes about a minute.

RESULTS

Several default plots are generated. Among them are the plots seen in [Figure 2](#) and [Figure 3](#) that show the oxygen and hydrogen mole fraction distribution, respectively, at a cell voltage of 0.5 V.

Polarization Curve

The following instructions reproduce the plot of the polarization curve for the SOFC (see [Figure 5](#)).

- 1 In the **Results** toolbar, click  **ID Plot Group**.
- 2 In the **Settings** window for **ID Plot Group**, type Polarization Curve in the **Label** text field.
- 3 Click to expand the **Title** section. From the **Title type** list, choose **None**.
- 4 Locate the **Plot Settings** section.
- 5 Select the **x-axis label** checkbox. In the associated text field, type Average current density (A/m^2).
- 6 Select the **y-axis label** checkbox. In the associated text field, type Cell voltage (V).
- 7 Locate the **Legend** section. Clear the **Show legends** checkbox.

Global I

- 1 Right-click **Polarization Curve** and choose **Global**.
- 2 In the **Settings** window for **Global**, locate the **y-Axis Data** section.
- 3 In the table, enter the following settings:

Expression	Unit	Description
V_cell	V	Cell Voltage

- 4 Locate the **x-Axis Data** section. From the **Parameter** list, choose **Expression**.
- 5 In the **Expression** text field, type I_cell.
- 6 In the **Polarization Curve** toolbar, click  **Plot**.

Power vs. Current

Next, reproduce a plot showing the power output as a function of the cell voltage (Figure 6).

- 1 In the **Results** toolbar, click  **ID Plot Group**.
- 2 In the **Settings** window for **ID Plot Group**, type Power vs. Current in the **Label** text field.
- 3 Locate the **Title** section. From the **Title type** list, choose **None**.
- 4 Locate the **Plot Settings** section.
- 5 Select the **x-axis label** checkbox. In the associated text field, type Average current density (A/m^2).
- 6 Select the **y-axis label** checkbox. In the associated text field, type Average cell power (W/m^2).
- 7 Locate the **Legend** section. Clear the **Show legends** checkbox.

Global I

- 1 Right-click **Power vs. Current** and choose **Global**.
- 2 In the **Settings** window for **Global**, locate the **y-Axis Data** section.
- 3 In the table, enter the following settings:

Expression	Unit	Description
V_cell*I_cell	W/m ²	Average Cell Power



- 4 Locate the **x-Axis Data** section. From the **Parameter** list, choose **Expression**.
- 5 In the **Expression** text field, type I_cell.
- 6 In the **Power vs. Current** toolbar, click  **Plot**.

Electrolyte Current Density

Next reproduce the plot in [Figure 4](#) showing the current density in the unit cell at 0.5 V.

- 1 In the **Results** toolbar, click  **3D Plot Group**.
- 2 In the **Settings** window for **3D Plot Group**, type Electrolyte Current Density in the **Label** text field.
- 3 Click to expand the **Selection** section. From the **Geometric entity level** list, choose **Boundary**.
- 4 Select Boundary 9 only.

Surface 1

- 1 Right-click **Electrolyte Current Density** and choose **Surface**.
- 2 In the **Settings** window for **Surface**, click **Replace Expression** in the upper-right corner of the **Expression** section. From the menu, choose **Component 1 (comp1) > Hydrogen Fuel Cell > Electrolyte current density vector - A/m² > fc.llz - Electrolyte current density vector, z-component**.
- 3 In the **Electrolyte Current Density** toolbar, click  **Plot**.
- 4 Click the  **Zoom Extents** button in the **Graphics** toolbar.

DEFINITIONS

To evaluate the overpotentials associated with the different processes in the fuel cell, load a set of preset variables.

Variables 1

- 1 In the **Model Builder** window, under **Component 1 (comp1)** right-click **Definitions** and choose **Variables**.
- 2 In the **Settings** window for **Variables**, locate the **Variables** section.
- 3 Click  **Load from File**.
- 4 Browse to the model's Application Libraries folder and double-click the file `sofc_unit_cell_variables.txt`.

Some of the variable expressions are marked in orange, indicating missing integration operators. Add the needed operators as follows:

Integration 1 (intop1)

- 1 In the **Definitions** toolbar, click  **Nonlocal Couplings** and choose **Integration**.
- 2 In the **Settings** window for **Integration**, type `intop_cc` in the **Operator name** text field.
- 3 Locate the **Source Selection** section. From the **Geometric entity level** list, choose **Boundary**.

4 Select Boundaries 10 and 22 only.

Integration 2 (intop2)

- 1 In the **Definitions** toolbar, click  **Nonlocal Couplings** and choose **Integration**.
- 2 In the **Settings** window for **Integration**, type intop_h2_gde in the **Operator name** text field.
- 3 Locate the **Source Selection** section. From the **Selection** list, choose **Anode Gas Diffusion Electrode**.

Integration 3 (intop3)

- 1 In the **Definitions** toolbar, click  **Nonlocal Couplings** and choose **Integration**.
- 2 In the **Settings** window for **Integration**, type intop_o2_gde in the **Operator name** text field.
- 3 Locate the **Source Selection** section. From the **Selection** list, choose **Cathode Gas Diffusion Electrode**.

Integration 4 (intop4)

- 1 In the **Definitions** toolbar, click  **Nonlocal Couplings** and choose **Integration**.
- 2 In the **Settings** window for **Integration**, type intop_mem in the **Operator name** text field.
- 3 Locate the **Source Selection** section. From the **Selection** list, choose **Membrane**.
You may now go back to the variables node and check so that the orange highlighting of the expressions in the variable list is no longer present.

STUDY 1

In order to make the new variable expressions available in the solution data sets, you need to update the solution.

- 1 In the **Study** toolbar, click  **Update Solution**.

RESULTS

Plot the various overpotential variables versus the cell current density as follows:

Overpotentials Comparison

- 1 In the **Results** toolbar, click  **ID Plot Group**.
- 2 In the **Settings** window for **ID Plot Group**, type Overpotentials Comparison in the **Label** text field.

Global 1

- 1 Right-click **Overpotentials Comparison** and choose **Global**.

- 2 In the **Settings** window for **Global**, click **Add Expression** in the upper-right corner of the **y-Axis Data** section. From the menu, choose **Component I (comp1) > Definitions > Variables > eta_phil - Cell-averaged electrolyte transport overpotential - V**.
- 3 Click **Add Expression** in the upper-right corner of the **y-Axis Data** section. From the menu, choose **Component I (comp1) > Definitions > Variables > eta_phis - Cell-averaged electron transport overpotential - V**.
- 4 Click **Add Expression** in the upper-right corner of the **y-Axis Data** section. From the menu, choose **Component I (comp1) > Definitions > Variables > eta_act_h2 - Cell-averaged hydrogen oxidation activation overpotential - V**.
- 5 Click **Add Expression** in the upper-right corner of the **y-Axis Data** section. From the menu, choose **Component I (comp1) > Definitions > Variables > eta_act_o2 - Cell-averaged oxygen reduction activation overpotential - V**.
- 6 Click **Replace Expression** in the upper-right corner of the **x-Axis Data** section. From the menu, choose **Component I (comp1) > Definitions > I_cell - Cell Current Density Probe - A/m²**.
- 7 In the **Overpotentials Comparison** toolbar, click  **Plot**.
- 8 Click to expand the **Legends** section. From the **Legends** list, choose **Manual**.
- 9 In the table, enter the following settings:

Legends

Electrolyte transport

Electron transport

Hydrogen oxidation activation

Oxygen reduction activation

Overpotentials Comparison

- 1 In the **Model Builder** window, click **Overpotentials Comparison**.
- 2 In the **Settings** window for **ID Plot Group**, locate the **Plot Settings** section.
- 3 Select the **x-axis label** checkbox. In the associated text field, type Average cell current density (A/m²).
- 4 Select the **y-axis label** checkbox. In the associated text field, type Overpotential (V).
- 5 Click to expand the **Title** section. From the **Title type** list, choose **None**.
- 6 Locate the **Legend** section. From the **Position** list, choose **Upper left**.

7 In the **Overpotentials Comparison** toolbar, click  **Plot**.

