



Low-Temperature PEM Fuel Cell with Serpentine Flow Field

Introduction

Water management is crucial for low-temperature polymer electrolyte fuel cell (PEMFC) operation. Water is produced on the air (cathode) side in the oxygen reduction reaction, but may permeate through the membrane to the hydrogen (anode side). Running the cell under too wet conditions may result in mass transport limitations of gases due to flooding of liquid water in the pores, whereas running the cell under too dry conditions may result in poor performance due to a low ohmic conductivity in the ionomer (polymer electrolyte) used in the membrane and catalytic layers.

This tutorial explores the current distribution in a low-temperature PEMFC when using serpentine flow field patterns, in combination with operating the cell in counter-flow mode so that the oxygen and hydrogen inlet flow streams are located at opposite sides (in the in-plane direction of the membrane) of the cell. Relatively dry inlet gas compositions are used so that the cell relies on self-humidification for achieving good performance.

For a more detailed analysis and discussion of the local transport phenomena of the fuel cell membrane–electrode assembly (MEA), see also the [Transport Phenomena in a Polymer Electrolyte Fuel Cell Membrane Electrode Assembly](#) tutorial.

Model Definition

Figure 1 shows the model geometry. The MEA is sandwiched between the anode and cathode gas diffusion layers, and the flow field channels, with the location of the gas stream inlets as indicated in the figure.

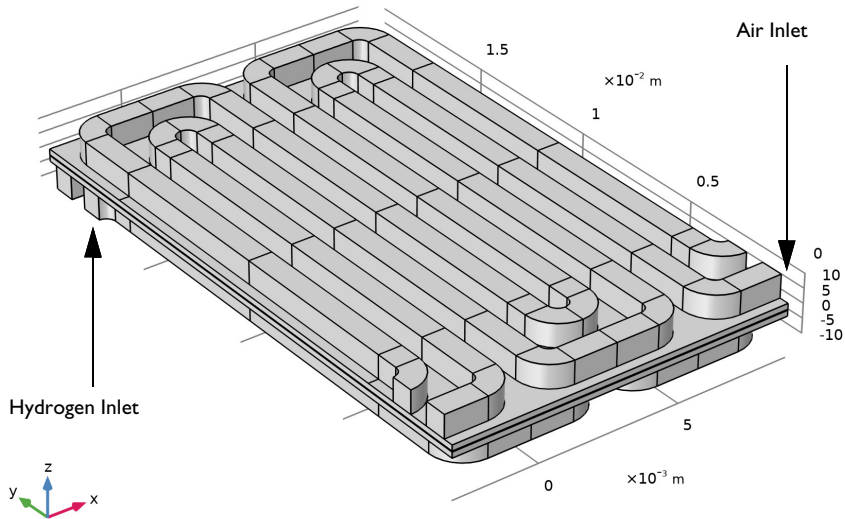

Figure 1: Model geometry. The fuel cell MEA is sandwiched between two gas diffusion layers, and the hydrogen and oxygen serpentine flow channels. The air side is located above the MEA, the hydrogen side is located below the MEA. The gas inlet positions are indicated in the figure.

The model solves for the charge balance (the electrode and electrolyte phase potentials) in the gas diffusion layers and the membrane, as well as the mass transfer (the molar fractions) and momentum transport (pressure and velocity) in the gas phase on each side of the membrane. The membrane transport of water, due to both diffusion (permeation) and migration (electroosmotic drag) is also included in the model.

The cell temperature is 70°C, with the relative humidities of the hydrogen and air inlet streams humidified to 25 and 75%, respectively. The molar flow rates of hydrogen and oxygen are set to be proportional to the total current, with a 20% excess of hydrogen and a 150% excess of oxygen (that is, using a hydrogen and oxygen flow stoichiometry of 1.2 and 2.5, respectively).

The model is defined using the Hydrogen Fuel Cell interface and solved using an Auxiliary sweep, ramping up the average cell current density from 0.01 to 1 A/cm². See the [Notes About the COMSOL Implementation](#) and the [Modeling Instructions](#) below, and the [Transport Phenomena in a Polymer Electrolyte Fuel Cell Membrane Electrode Assembly](#) tutorial for more details on the model setup.

Results and Discussion

Figure 2 shows the cell polarization curve.

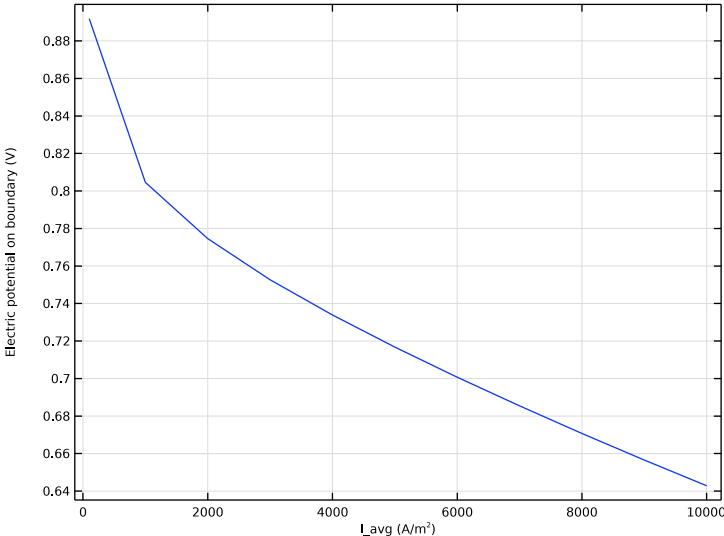

Figure 2: Polarization plot.

Figure 3 and Figure 4 show the streamlines of hydrogen and oxygen, and the corresponding molar fractions for current density of 1 A/cm^2 . The molar fractions decrease toward the outlets.

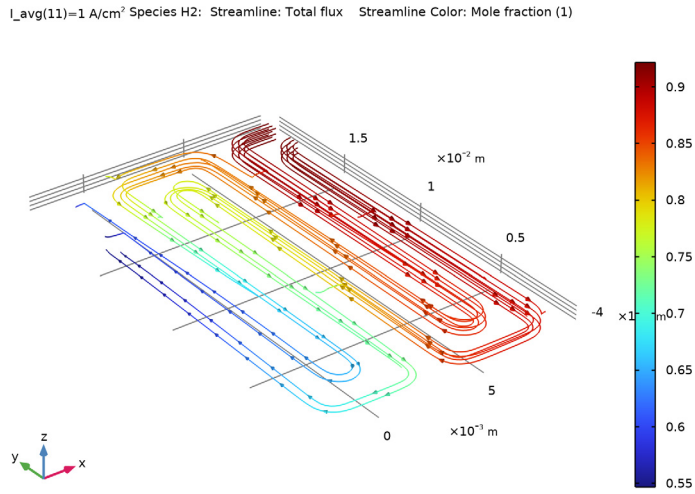

Figure 3: Hydrogen total flux streamlines and molar fraction.

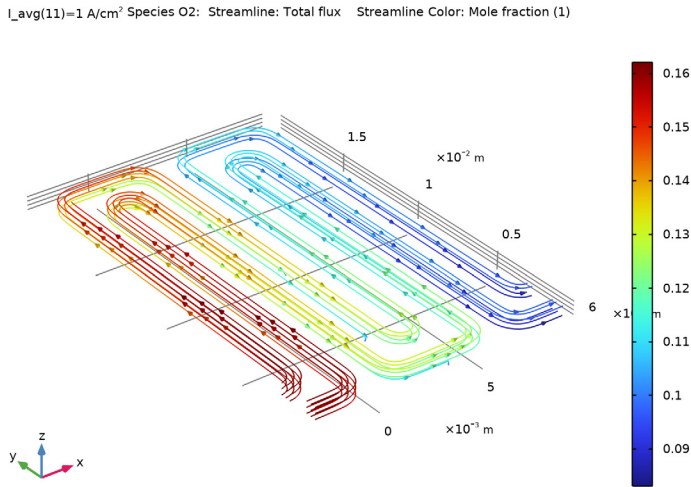

Figure 4: Oxygen total flux streamlines and molar fractions.

Figure 5 shows the water activity (which equals the relative humidity in the gas phase) in the channels and in the membrane at 1 A/cm^2 . For both gas streams, the water activity increases toward the outlet. On the oxygen side the increased water activity is a direct effect of the water being produced in the cell. On the hydrogen side, the water activity increase is related mainly to the depletion of hydrogen — that is, the water fraction (at 25% relative humidity at the inlet) of the gas stream increases as hydrogen is consumed — but also to water membrane transport between the two gas compartments.

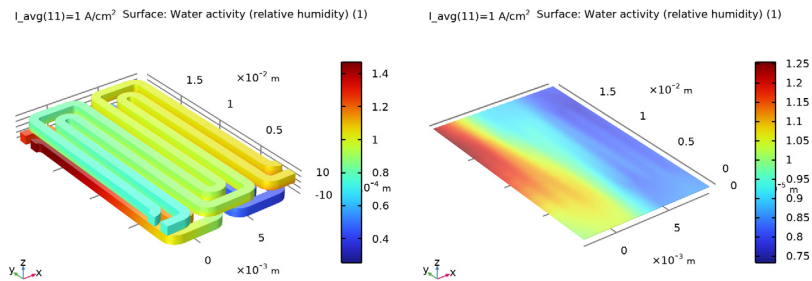

Figure 5: Left: Relative humidity in the channels. Right: Water activity in the membrane.

Figure 6 shows the electrolyte conductivity and the electrolyte current density in the z direction in the membrane. The conductivity depends on the water activity, which has an effect on the current density distribution in the cell, with generally lower current densities in the low conductivity regions. However, the current density distribution also relates strongly to the oxygen levels, lowering the current densities in areas less accessible to oxygen.

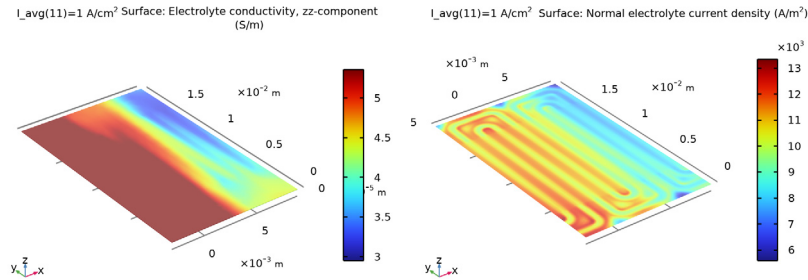

Figure 6: Left: Electrolyte conductivity in the membrane. Right: Electrolyte current density in the z direction.

Finally, Figure 7 shows the membrane water flux in the z direction. Close to the oxygen inlet/hydrogen outlet, where the hydrogen side is more humidified than the oxygen side, the flux is positive, indicating that water is transported from the hydrogen to the oxygen

side. Close to the oxygen inlet/hydrogen outlet, the water is transported in the negative z direction through the membrane.

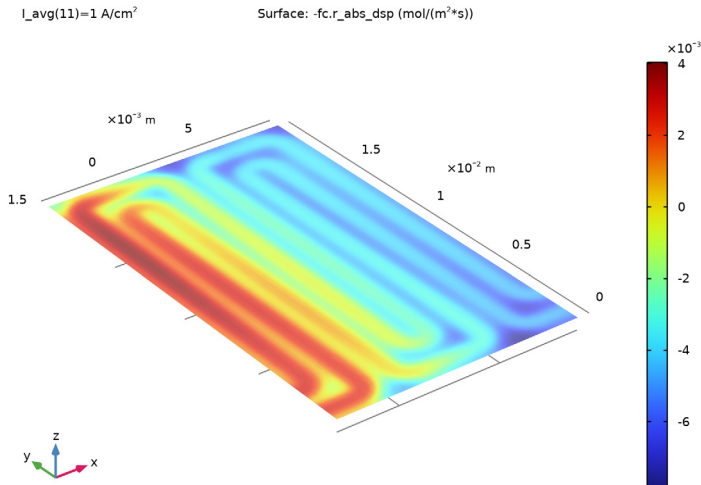

Figure 7: Water flux in the z direction of the membrane.

Notes About the COMSOL Implementation

The geometry is defined using an Assembly in the final Union node of the geometry sequence. This creates a geometry consisting of two parts, with a common boundary pair in the middle of the membrane. In this way, nonmatching meshes may be used on each side of the membrane. An automatically defined Identity Pair and a Continuity boundary node set up the needed boundary condition at the boundary pair between the assembly parts.

The gas diffusion electrodes of the MEA are not included explicitly in the geometry, and are instead defined as Thin Gas Diffusion Electrodes boundary nodes when defining the physics. This saves memory since the gas diffusion electrodes need not to be meshed.

The gas diffusion layers use anisotropic electronic conductivities, featuring about an order of magnitude higher conductivities in the in-plane (x and y) directions compared to the through-plane (z) direction).

To save computational time, Darcy's law is used to solve for the flow in both the flow channels as well as in the gas diffusion layers. In the channels, considering the constant

rectangular cross section, the permeability was derived based on an expression by Boussinesq (Ref. 1) originally derived for straight channels. See the [Solid Oxide Electrolyzer](#) tutorial for how define the flow using the Navier–Stokes and Brinkman equations instead.

The study sequence is set up in three steps: The first step solves for the potential variables for the initial gas composition, the second step solves for velocity distribution by computing the pressure variables, the third step solves the full problem, ramping up the current using an Auxiliary sweep.

The default Direct solver is disabled by enabling an iterative multigrid solver in study step 3. This reduces the memory required for solving the model.

The geometry is fully parameterized. In the modeling instructions a smaller version of the geometry is solved for first before solving for the full geometry.

Reference

1. J. Boussinesq, “Mémoire sur l'influence des Frottements dans les Mouvements Réguliers des Fluids,” *J. Math. Pures Appl.*, vol. 13, no. 2, pp. 377–424, 1868.

Application Library path: Fuel_Cell_and_Electrolyzer_Module/Fuel_Cells/pemfc_serpentine_flow_field



Modeling Instructions

From the **File** menu, choose **New**.

NEW

In the **New** window, click  **Model Wizard**.

MODEL WIZARD

- 1 In the **Model Wizard** window, click  **3D**.
- 2 In the **Select Physics** tree, select **Electrochemistry > Hydrogen Fuel Cells > Proton Exchange Membrane (fc)**.
- 3 Click **Add**.
- 4 Click  **Study**.

5 In the **Select Study** tree, select **Preset Studies for Selected Physics Interfaces > Stationary with Initialization**.

6 Click **Done**.

GEOMETRY I

1 In the **Geometry** toolbar, click **Insert Sequence** and choose **Insert Sequence**.

2 Browse to the model's Application Libraries folder and double-click the file `pemfc_serpentine_flow_field_geom_sequence.mph`.

3 In the **Geometry** toolbar, click  **Build All**.

4 In the **Model Builder** window, under **Component 1 (comp1)** click **Geometry I**.

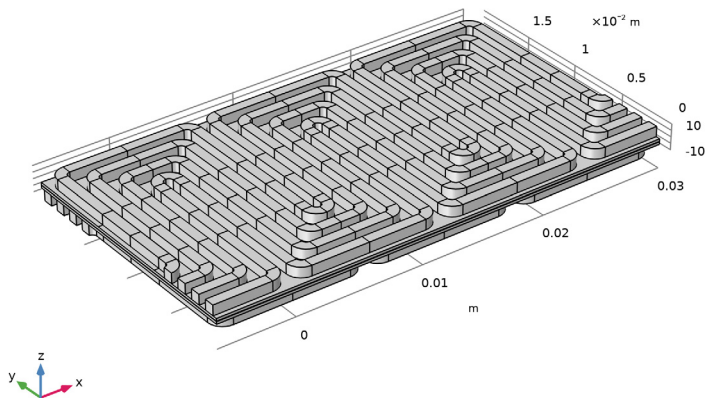

GLOBAL DEFINITIONS

Geometry Parameters

The geometry is fully parameterized. Create a smaller version of the geometry to use while setting up the physics.

1 In the **Model Builder** window, under **Global Definitions** click **Parameters I**.

2 In the **Settings** window for **Parameters**, type `Geometry Parameters` in the **Label** text field.

3 Locate the **Parameters** section. In the table, enter the following settings:

Name	Expression	Value	Description
W_plate_min	10[mm]	0.01 m	Minimum plate width
N_ch	1	1	Number of channels
N_repeat	1	1	Number of repeating units

GEOMETRY I

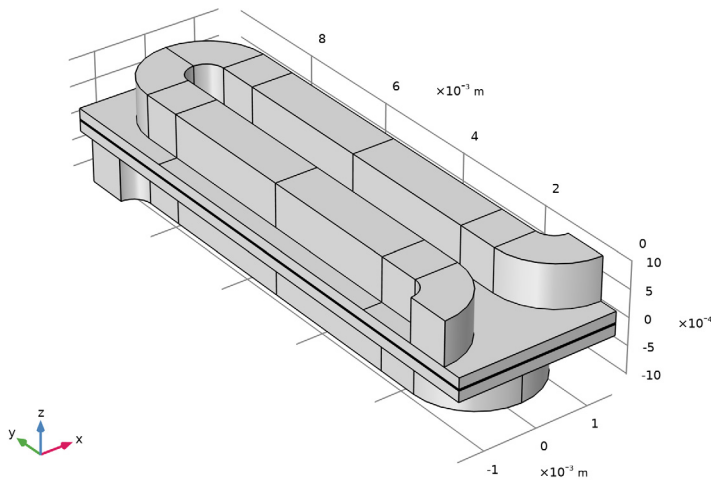

- 1 In the **Geometry** toolbar, click  **Build All**.
- 2 In the **Model Builder** window, under **Component 1 (comp1)** click **Geometry 1**.



- 3 In the **Model Builder** window, collapse the **Geometry 1** node.
- 4 Click the  **Zoom Extents** button in the **Graphics** toolbar.

GLOBAL DEFINITIONS

Physics Parameters

- 1 In the **Home** toolbar, click  **Parameters** and choose **Add > Parameters**.
- 2 In the **Settings** window for **Parameters**, type **Physics Parameters** in the **Label** text field.
- 3 Locate the **Parameters** section. Click  **Load from File**.



- 4 Browse to the model's Application Libraries folder and double-click the file `pemfc_serpentine_flow_field_physics_parameters.txt`.

Change the hydrogen stoichiometry (inlet flow rate) and inlet relative humidity. This will make it easier to solve for the smaller geometry. You will go back and revert these changes later before solving for the full model.

- 5 In the table, enter the following settings:

Name	Expression	Value	Description
stoich_H2	3	3	Hydrogen flow stoichiometry
RH_an	50[%]	0.5	Inlet relative humidity, anode side

ADD MATERIAL

- 1 In the **Materials** toolbar, click  **Add Material** to open the **Add Material** window.
- 2 Go to the **Add Material** window.
- 3 In the tree, select **Fuel Cell and Electrolyzer > Polymer Electrolytes > Nafion®**, EW 1100, Vapor Equilibrated, Protonated.
- 4 Right-click and choose **Add to Component 1 (comp1)**.
- 5 In the **Materials** toolbar, click  **Add Material** to close the **Add Material** window.

HYDROGEN FUEL CELL (FC)

- 1 In the **Settings** window for **Hydrogen Fuel Cell**, locate the **H2 Gas Mixture** section.
- 2 Find the **Transport mechanisms** subsection. Select the **Use Darcy's Law for momentum transport** checkbox.
- 3 Locate the **O2 Gas Mixture** section. Select the **Use Darcy's Law for momentum transport** checkbox.

Membrane 1

In the **Physics** toolbar, click  **Domains** and choose **Membrane**.

HYDROGEN FUEL CELL (FC)

- 1 In the **Model Builder** window, expand the **Component 1 (comp1) > Geometry 1** node, then click **Component 1 (comp1) > Hydrogen Fuel Cell (fc) > Membrane 1**.
- 2 In the **Settings** window for **Membrane**, locate the **Domain Selection** section.
- 3 From the **Selection** list, choose **Membrane**.

GEOMETRY 1

In the **Model Builder** window, collapse the **Component 1 (comp1) > Geometry 1** node.

HYDROGEN FUEL CELL (FC)

- 1 In the **Model Builder** window, under **Component 1 (comp1)** click **Hydrogen Fuel Cell (fc)**.
- 2 In the **Settings** window for **Hydrogen Fuel Cell**, click to expand the **Membrane Transport** section.
- 3 Select the **Electroosmotic water drag** checkbox.

Initial Values 1

- 1 In the **Model Builder** window, under **Component 1 (comp1) > Hydrogen Fuel Cell (fc) > Membrane 1** click **Initial Values 1**.
- 2 In the **Settings** window for **Initial Values**, locate the **Initial Values** section.
- 3 In the $a_{w,0}$ text field, type $(RH_{cath}+RH_{an})/2$.
- 4 In the T_0 text field, type T_{hum} .

Water Absorption-Desorption, H2 Side 1

- 1 In the **Model Builder** window, click **Water Absorption-Desorption, H2 Side 1**.
- 2 In the **Settings** window for **Water Absorption-Desorption, H2 Side**, locate the **Absorption-Desorption Condition** section.
- 3 From the **Electrolyte material** list, choose **Nafion®, EW 1100, Vapor Equilibrated, Protonated (mat1)**.

Water Absorption-Desorption, O2 Side 1

- 1 In the **Model Builder** window, click **Water Absorption-Desorption, O2 Side 1**.
- 2 In the **Settings** window for **Water Absorption-Desorption, O2 Side**, locate the **Absorption-Desorption Condition** section.
- 3 From the **Electrolyte material** list, choose **Nafion®, EW 1100, Vapor Equilibrated, Protonated (mat1)**.

H2 Gas Diffusion Layer 1

- 1 In the **Physics** toolbar, click  **Domains** and choose **H2 Gas Diffusion Layer**.
- 2 In the **Settings** window for **H2 Gas Diffusion Layer**, locate the **Domain Selection** section.
- 3 From the **Selection** list, choose **H2 GDL**.

4 Locate the **Electrode Charge Transport** section. From the list, choose **Diagonal**.

The GDLs feature anisotropy with regards to the electron conductivity. The first, second and third values on the diagonal refer to the conductivities in the x , y , and z directions, respectively.

5 Specify the σ_g matrix as

sigmas_GDL_IP	0	0
0	sigmas_GDL_IP	0
0	0	sigmas_GDL_TP

6 Locate the **Gas Transport** section. In the ϵ_g text field, type epsg_GDL.

7 In the κ_g text field, type kappag_GDL.

O2 Gas Diffusion Layer I

1 In the **Physics** toolbar, click  **Domains** and choose **O2 Gas Diffusion Layer**.

2 In the **Settings** window for **O2 Gas Diffusion Layer**, locate the **Domain Selection** section.

3 From the **Selection** list, choose **O2 GDL**.

4 Locate the **Electrode Charge Transport** section. From the list, choose **Diagonal**.

5 Specify the σ_g matrix as

sigmas_GDL_TP	0	0
0	sigmas_GDL_TP	0
0	0	sigmas_GDL_IP

6 Locate the **Gas Transport** section. In the ϵ_g text field, type epsg_GDL.

7 In the κ_g text field, type kappag_GDL.

H2 Gas Flow Channel I

1 In the **Physics** toolbar, click  **Domains** and choose **H2 Gas Flow Channel**.

2 In the **Settings** window for **H2 Gas Flow Channel**, locate the **Domain Selection** section.

3 From the **Selection** list, choose **H2 Channels**.

4 Locate the **Gas Transport** section. From the list, choose **Straight channels**.

5 In the H text field, type H_ch.

6 In the W text field, type W_ch.

O2 Gas Flow Channel I

1 In the **Physics** toolbar, click  **Domains** and choose **O2 Gas Flow Channel**.

- 2 In the **Settings** window for **O2 Gas Flow Channel**, locate the **Domain Selection** section.
- 3 From the **Selection** list, choose **O2 Channels**.
- 4 Locate the **Gas Transport** section. From the list, choose **Straight channels**.
- 5 In the H text field, type H_ch.
- 6 In the W text field, type W_ch.

Thin H2 Gas Diffusion Electrode 1

- 1 In the **Physics** toolbar, click  **Boundaries** and choose **Thin H2 Gas Diffusion Electrode**.
- 2 In the **Settings** window for **Thin H2 Gas Diffusion Electrode**, locate the **Boundary Selection** section.
- 3 From the **Selection** list, choose **H2 GDE**.
- 4 Locate the **Electrode Thickness** section. In the d_{gde} text field, type L_CL.

Thin H2 Gas Diffusion Electrode Reaction 1

- 1 In the **Model Builder** window, click **Thin H2 Gas Diffusion Electrode Reaction 1**.
- 2 In the **Settings** window for **Thin H2 Gas Diffusion Electrode Reaction**, locate the **Electrode Kinetics** section.
- 3 In the $i_{0,ref}(T)$ text field, type i0_H2_ref.
- 4 Locate the **Active Specific Surface Area** section. In the a_v text field, type a_CL.

Thin O2 Gas Diffusion Electrode 1

- 1 In the **Physics** toolbar, click  **Boundaries** and choose **Thin O2 Gas Diffusion Electrode**.
- 2 In the **Settings** window for **Thin O2 Gas Diffusion Electrode**, locate the **Boundary Selection** section.
- 3 From the **Selection** list, choose **O2 GDE**.
- 4 Locate the **Electrode Thickness** section. In the d_{gde} text field, type L_CL.

Thin O2 Gas Diffusion Electrode Reaction 1

- 1 In the **Model Builder** window, click **Thin O2 Gas Diffusion Electrode Reaction 1**.
- 2 In the **Settings** window for **Thin O2 Gas Diffusion Electrode Reaction**, locate the **Electrode Kinetics** section.
- 3 In the $i_{0,ref}(T)$ text field, type i0_O2_ref.
- 4 In the α_a text field, type 3.
- 5 Locate the **Active Specific Surface Area** section. In the a_v text field, type a_CL.

Electronic Conducting Phase I

In the **Model Builder** window, under **Component 1 (comp1) > Hydrogen Fuel Cell (fc)** click **Electronic Conducting Phase I**.

Initial Values, O2 Domains I

- 1 In the **Physics** toolbar, click  **Attributes** and choose **Initial Values, O2 Domains**.
- 2 In the **Settings** window for **Initial Values, O2 Domains**, locate the **Domain Selection** section.
- 3 From the **Selection** list, choose **All domains**.

Electronic Conducting Phase I

In the **Model Builder** window, click **Electronic Conducting Phase I**.

Electric Ground I

- 1 In the **Physics** toolbar, click  **Attributes** and choose **Electric Ground**.
- 2 In the **Settings** window for **Electric Ground**, locate the **Boundary Selection** section.
- 3 From the **Selection** list, choose **H2 Current Collector**.
- 4 Locate the **Contact Resistance** section. Select the **Include contact resistance** checkbox.
- 5 In the R_c text field, type Rc.

Electronic Conducting Phase I

In the **Model Builder** window, click **Electronic Conducting Phase I**.

Electrode Current I

- 1 In the **Physics** toolbar, click  **Attributes** and choose **Electrode Current**.
- 2 In the **Settings** window for **Electrode Current**, locate the **Boundary Selection** section.
- 3 From the **Selection** list, choose **O2 Current Collector**.
- 4 Locate the **Electrode Current** section. In the $I_{s,total}$ text field, type -I_tot.
- 5 Locate the **Contact Resistance** section. Select the **Include contact resistance** checkbox.
- 6 In the R_c text field, type Rc.

Initial Values I

- 1 In the **Model Builder** window, under **Component 1 (comp1) > Hydrogen Fuel Cell (fc) > H2 Gas Phase I** click **Initial Values I**.
- 2 In the **Settings** window for **Initial Values**, locate the **Initial Composition** section.
- 3 In the x_{0,H_2O} text field, type x_H2O_an.

H2 Gas Phase I

In the **Model Builder** window, click **H2 Gas Phase I**.

H2 Inlet 1

- 1 In the **Physics** toolbar, click  **Attributes** and choose **H2 Inlet**.
- 2 In the **Settings** window for **H2 Inlet**, locate the **Boundary Selection** section.
- 3 From the **Selection** list, choose **H2 Inlets**.
Specify the mass flow rates to make the inlet gas flow proportional to the cell current.
- 4 Locate the **Mixture Specification** section. From the list, choose **Mass flow rates**.
- 5 In the J_{0,H_2O} text field, type $m_H_2O_an$.
- 6 In the ω_{0,bnd,H_2O} text field, type $w_H_2O_an$.
- 7 Locate the **Flow Boundary Condition** section. From the list, choose **Total mass flow rate**.
- 8 In the J_0 text field, type m_an .

H2 Gas Phase 1

In the **Model Builder** window, click **H2 Gas Phase 1**.

H2 Outlet 1

- 1 In the **Physics** toolbar, click  **Attributes** and choose **H2 Outlet**.
- 2 In the **Settings** window for **H2 Outlet**, locate the **Boundary Selection** section.
- 3 From the **Selection** list, choose **H2 Outlets**.

Initial Values 1

- 1 In the **Model Builder** window, under **Component 1 (comp1) > Hydrogen Fuel Cell (fc) > O2 Gas Phase 1** click **Initial Values 1**.
- 2 In the **Settings** window for **Initial Values**, locate the **Initial Composition** section.
- 3 In the x_{0,H_2O} text field, type $x_H_2O_cath$.
- 4 In the x_{0,N_2} text field, type $x_N_2_cath$.

O2 Gas Phase 1

In the **Model Builder** window, click **O2 Gas Phase 1**.

O2 Inlet 1

- 1 In the **Physics** toolbar, click  **Attributes** and choose **O2 Inlet**.
- 2 In the **Settings** window for **O2 Inlet**, locate the **Boundary Selection** section.
- 3 From the **Selection** list, choose **O2 Inlets**.
- 4 Locate the **Mixture Specification** section. From the list, choose **Mass flow rates**.
- 5 In the J_{0,H_2O} text field, type $m_H_2O_cath$.
- 6 In the J_{0,N_2} text field, type m_N_2 .

- 7 In the $\omega_{0,\text{bnd},\text{H}_2\text{O}}$ text field, type `w_H2O_cath`.
- 8 In the $\omega_{0,\text{bnd},\text{N}_2}$ text field, type `w_N2`.
- 9 Locate the **Flow Boundary Condition** section. From the list, choose **Total mass flow rate**.
- 10 In the J_0 text field, type `m_cath`.

O2 Gas Phase 1

In the **Model Builder** window, click **O2 Gas Phase 1**.

O2 Outlet 1

- 1 In the **Physics** toolbar, click  **Attributes** and choose **O2 Outlet**.
- 2 In the **Settings** window for **O2 Outlet**, locate the **Boundary Selection** section.
- 3 From the **Selection** list, choose **O2 Outlets**.

GLOBAL DEFINITIONS

Default Model Inputs

- 1 In the **Model Builder** window, under **Global Definitions** click **Default Model Inputs**.
- 2 In the **Settings** window for **Default Model Inputs**, locate the **Browse Model Inputs** section.
- 3 In the tree, select **General > Temperature (K) - minput.T**.
- 4 Find the **Expression for remaining selection** subsection. In the **Temperature** text field, type `T`.

MESH 1

A user-defined mesh is required for this model. Use mapped and swept meshes in order to reduce the total number of mesh elements.

With the last **Union** node in the geometry sequence set to **Assembly**, the mesh nodes do not need to match along the pair boundaries between the two parts of the assembly at the center of the membrane. In this way different swept meshes can be used on each side of the membrane.

Mapped 1

In the **Mesh** toolbar, click  **More Generators** and choose **Mapped**.

Size

- 1 In the **Model Builder** window, click **Size**.
- 2 In the **Settings** window for **Size**, click to expand the **Element Size Parameters** section.
- 3 In the **Maximum element size** text field, type `W_ch/2`.

Mapped 1

- 1 In the **Model Builder** window, click **Mapped 1**.
- 2 In the **Settings** window for **Mapped**, locate the **Boundary Selection** section.
- 3 From the **Selection** list, choose **Channel Mesh Sweep Faces**.

Distribution 1

- 1 Right-click **Mapped 1** and choose **Distribution**.
- 2 In the **Settings** window for **Distribution**, locate the **Edge Selection** section.
- 3 From the **Selection** list, choose **All edges**.
- 4 Locate the **Distribution** section. From the **Distribution type** list, choose **Predefined**.
- 5 In the **Number of elements** text field, type 4.
- 6 In the **Element ratio** text field, type 2.
- 7 Select the **Symmetric distribution** checkbox.

Swept 1

- 1 In the **Mesh** toolbar, click  **Swept**.
- 2 In the **Settings** window for **Swept**, locate the **Domain Selection** section.
- 3 From the **Geometric entity level** list, choose **Domain**.
- 4 From the **Selection** list, choose **Channel Sweep Mesh Domains**.

Size 1

- 1 Right-click **Swept 1** and choose **Size**.
- 2 In the **Settings** window for **Size**, locate the **Element Size** section.
- 3 Click the **Custom** button.
- 4 Locate the **Element Size Parameters** section.
- 5 Select the **Maximum element size** checkbox. In the associated text field, type $W_{ch}/1.1$.

6 Click  **Build All**.

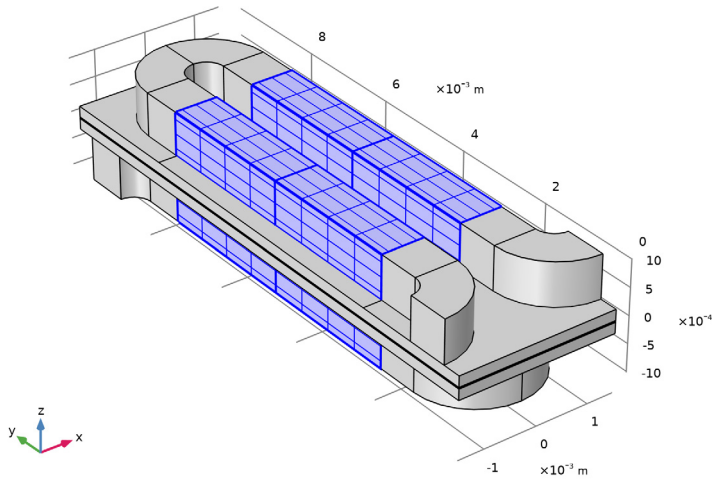

Mapped 2

- 1 In the **Mesh** toolbar, click  **More Generators** and choose **Mapped**.
- 2 In the **Settings** window for **Mapped**, locate the **Boundary Selection** section.
- 3 From the **Selection** list, choose **Mapped Mesh Current Collector Boundaries**.

4 Click  **Build Selected.**

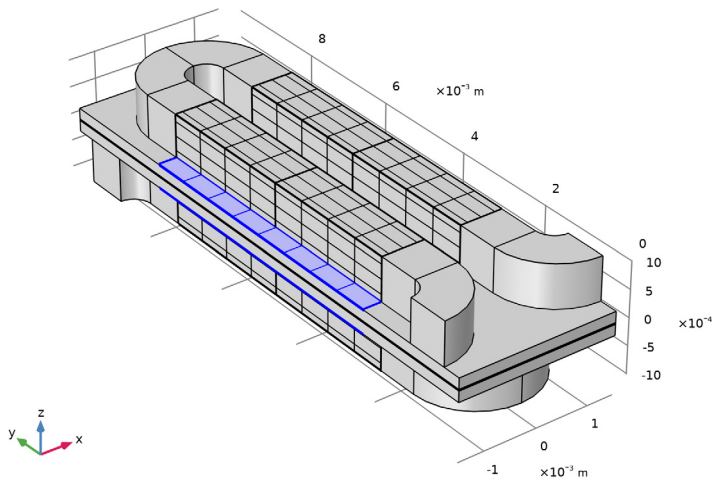

Free Triangular 1

- 1 In the **Mesh** toolbar, click  **More Generators** and choose **Free Triangular**.
- 2 In the **Settings** window for **Free Triangular**, locate the **Boundary Selection** section.
- 3 From the **Selection** list, choose **Triangular Mesh Current Collector Boundaries**.

4 Click  **Build Selected**.

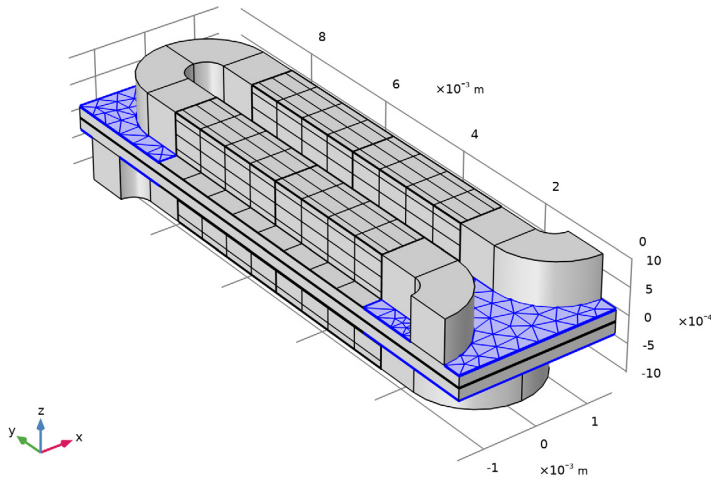

Boundary Layers 1

- 1 In the **Mesh** toolbar, click  **Boundary Layers**.
- 2 In the **Settings** window for **Boundary Layers**, locate the **Geometric Entity Selection** section.
- 3 From the **Geometric entity level** list, choose **Boundary**.
- 4 From the **Selection** list, choose **Current Collectors**.

Boundary Layer Properties

- 1 In the **Model Builder** window, click **Boundary Layer Properties**.
- 2 In the **Settings** window for **Boundary Layer Properties**, locate the **Edge Selection** section.
- 3 From the **Selection** list, choose **Channels**.
- 4 Locate the **Layers** section. In the **Number of layers** text field, type 2.
- 5 From the **Thickness specification** list, choose **First layer**.
- 6 In the **Thickness** text field, type $W_{rib}/10$.

7 Click  **Build Selected**.

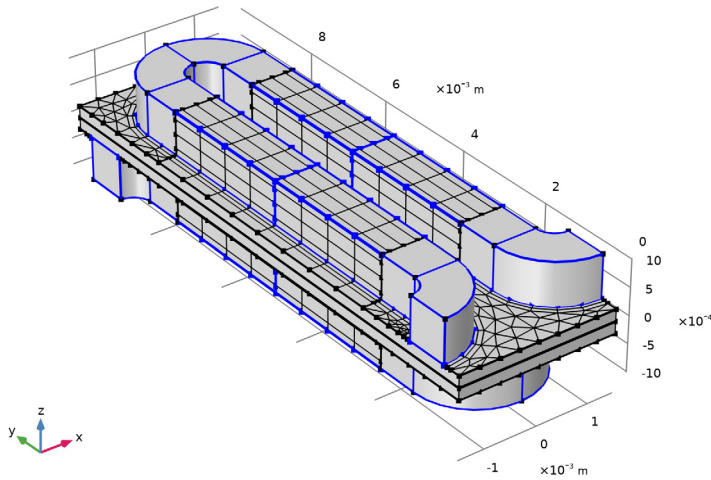

Free Tetrahedral I

- 1 In the **Mesh** toolbar, click  **Free Tetrahedral**.
- 2 In the **Settings** window for **Free Tetrahedral**, locate the **Domain Selection** section.
- 3 From the **Geometric entity level** list, choose **Domain**.
- 4 From the **Selection** list, choose **Channel Tet Mesh Domains**.

Size I

- 1 Right-click **Free Tetrahedral I** and choose **Size**.
- 2 In the **Settings** window for **Size**, locate the **Element Size** section.
- 3 Click the **Custom** button.
- 4 Locate the **Element Size Parameters** section.
- 5 Select the **Maximum element size** checkbox. In the associated text field, type $W_{ch}/2 \cdot 1$.

6 Click  **Build Selected.**

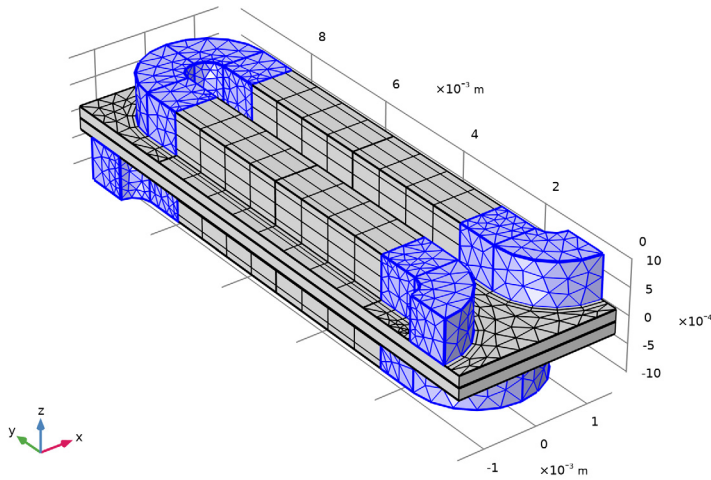

Swept 2

In the **Mesh** toolbar, click  **Swept.**

Distribution 1

- 1 Right-click **Swept 2** and choose **Distribution**.
- 2 In the **Settings** window for **Distribution**, locate the **Domain Selection** section.
- 3 From the **Selection** list, choose **GDL**.
- 4 Locate the **Distribution** section. In the **Number of elements** text field, type 4.

Distribution 2

- 1 In the **Model Builder** window, right-click **Swept 2** and choose **Distribution**.
- 2 In the **Settings** window for **Distribution**, locate the **Domain Selection** section.
- 3 From the **Selection** list, choose **Membrane**.
- 4 Locate the **Distribution** section. In the **Number of elements** text field, type 4.

5 Click  **Build All**.

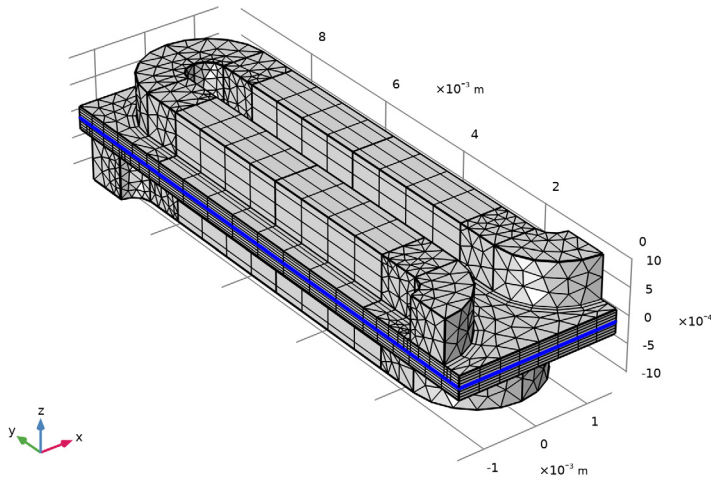

6 In the **Model Builder** window, collapse the **Mesh 1** node.

STUDY 1

Step 1: Current Distribution Initialization

Change the current distribution type to also include activation overpotentials (secondary). This will make the initial values for the subsequent study steps more accurate.

1 In the **Model Builder** window, under **Study 1** click **Step 1: Current Distribution Initialization**.

2 In the **Settings** window for **Current Distribution Initialization**, locate the **Study Settings** section.

3 From the **Current distribution type** list, choose **Secondary**.



Stationary - Pressures Only

1 In the **Model Builder** window, click **Step 2: Stationary**.

2 In the **Settings** window for **Stationary**, type Stationary - Pressures Only in the **Label** text field.

Create a third study step that will solve for the whole problem, for a range of currents densities.

Stationary - All Physics

- 1 In the **Study** toolbar, click  **Study Steps** and choose **Stationary** > **Stationary**.
- 2 In the **Settings** window for **Stationary**, type Stationary - All Physics in the **Label** text field.
- 3 Click to expand the **Study Extensions** section. Select the **Auxiliary sweep** checkbox.
- 4 Click  **Add**.
- 5 In the table, enter the following settings:

Parameter name	Parameter value list	Parameter unit
I_avg (Average cell current density)	I_avg_init range(I_avg_final/10, I_avg_final/10, I_avg_final)	A/cm ²

Solution 1 (sol1)

Generate the default solver and make some manual changes.

- 1 In the **Study** toolbar, click  **Show Default Solver**.
- 2 In the **Model Builder** window, expand the **Solution 1 (sol1)** node, then click **Dependent Variables 2**.
- 3 In the **Settings** window for **Dependent Variables**, locate the **General** section.
- 4 From the **Defined by study step** list, choose **User defined**.
The second study step should only solve for pressure variables.
- 5 In the **Model Builder** window, expand the **Study 1** > **Solver Configurations** > **Solution 1 (sol1)** > **Dependent Variables 2** node, then click **Chemical Potential (comp1.fc.mu0)**.
- 6 In the **Settings** window for **Field**, locate the **General** section.
- 7 Clear the **Solve for this field** checkbox.
- 8 In the **Model Builder** window, under **Study 1** > **Solver Configurations** > **Solution 1 (sol1)** > **Dependent Variables 2** click **Electrolyte Potential (comp1.fc.phil)**.
- 9 In the **Settings** window for **Field**, locate the **General** section.
- 10 Clear the **Solve for this field** checkbox.
- 11 In the **Model Builder** window, under **Study 1** > **Solver Configurations** > **Solution 1 (sol1)** > **Dependent Variables 2** click **Electric Potential (comp1.fc.phis)**.
- 12 In the **Settings** window for **Field**, locate the **General** section.
- 13 Clear the **Solve for this field** checkbox.

- 14 In the **Model Builder** window, under **Study 1 > Solver Configurations > Solution 1 (sol1) > Dependent Variables 2** click **Mass Fraction (compl.fc.wH2O_H2)**.
- 15 In the **Settings** window for **Field**, locate the **General** section.
- 16 Clear the **Solve for this field** checkbox.
- 17 In the **Model Builder** window, under **Study 1 > Solver Configurations > Solution 1 (sol1) > Dependent Variables 2** click **Mass Fraction (compl.fc.wH2O_O2)**.
- 18 In the **Settings** window for **Field**, locate the **General** section.
- 19 Clear the **Solve for this field** checkbox.
- 20 In the **Model Builder** window, under **Study 1 > Solver Configurations > Solution 1 (sol1) > Dependent Variables 2** click **Mass Fraction (compl.fc.wN2_O2)**.
- 21 In the **Settings** window for **Field**, locate the **General** section.
- 22 Clear the **Solve for this field** checkbox.
- 23 In the **Model Builder** window, under **Study 1 > Solver Configurations > Solution 1 (sol1) > Dependent Variables 2** click **Electric Potential on Boundary (compl.fc.ecph1.ecl.phis0)**.
- 24 In the **Settings** window for **State**, locate the **General** section.
- 25 Clear the **Solve for this state** checkbox.
- 26 In the **Model Builder** window, under **Study 1 > Solver Configurations > Solution 1 (sol1) > Dependent Variables 2** click **Boundary Mass Fraction (compl.fc.h2gasph1.h2in1.wbndH2O)**.
- 27 In the **Settings** window for **State**, locate the **General** section.
- 28 Clear the **Solve for this state** checkbox.
- 29 In the **Model Builder** window, under **Study 1 > Solver Configurations > Solution 1 (sol1) > Dependent Variables 2** click **Boundary Mass Fraction (compl.fc.o2gasph1.o2in1.wbndH2O)**.
- 30 In the **Settings** window for **State**, locate the **General** section.
- 31 Clear the **Solve for this state** checkbox.
- 32 In the **Model Builder** window, under **Study 1 > Solver Configurations > Solution 1 (sol1) > Dependent Variables 2** click **Boundary Mass Fraction (compl.fc.o2gasph1.o2in1.wbndN2)**.
- 33 In the **Settings** window for **State**, locate the **General** section.
- 34 Clear the **Solve for this state** checkbox.

All the modified nodes are marked with a small * in the corresponding icon in the model tree. Inspect all subnodes under the **Dependent Variables 2** node and make sure that all nonpressure variables are marked with a (*), and that all 4 pressure variables are left unmodified. (Two of the pressure variables are the pressures on each side of the

membrane. The other two pressures are auxiliary variables used to implement the total mass flow rate inlet conditions.)

35 In the **Model Builder** window, collapse the **Solution 1 (sol1)** node.

36 In the **Study** toolbar, click  **Compute**.

The model should now solve in a minute or two.

RESULTS

You may now proceed to reproduce the plots from the Results and Discussion section (but for your smaller geometry) as follows:

Mole Fraction, H2, Streamline (fc)

1 In the **Model Builder** window, under **Results** click **Mole Fraction, H2, Streamline (fc)**.

2 In the **Settings** window for **3D Plot Group**, locate the **Plot Settings** section.

3 Clear the **Plot dataset edges** checkbox.

Streamline 1

1 In the **Model Builder** window, expand the **Mole Fraction, H2, Streamline (fc)** node, then click **Streamline 1**.

2 In the **Settings** window for **Streamline**, locate the **Streamline Positioning** section.

3 From the **Positioning** list, choose **On selected entities**.

4 Locate the **Selection** section. From the **Selection** list, choose **H2 Inlets**.

5 Locate the **Coloring and Style** section. Find the **Point style** subsection. From the **Arrow distribution** list, choose **Equal time**.

6 In the **Mole Fraction, H2, Streamline (fc)** toolbar, click  **Plot**.

I_avg(11)=1 A/cm² Species H2: Streamline: Total flux Streamline Color: Mole fraction (1)

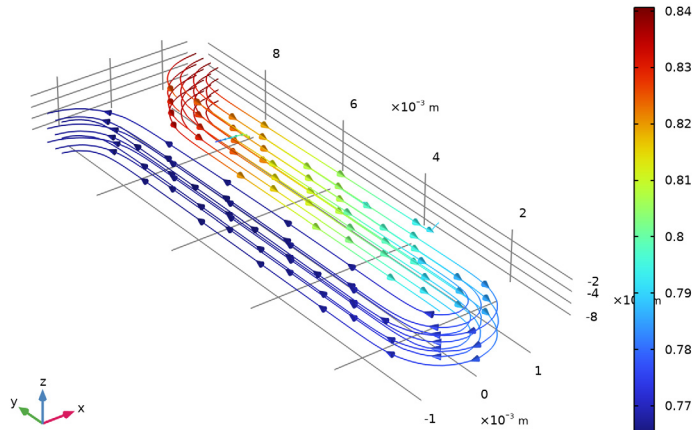

Mole Fraction, O2, Streamline (fc)

- 1 In the **Model Builder** window, under **Results** click **Mole Fraction, O2, Streamline (fc)**.
- 2 In the **Settings** window for **3D Plot Group**, locate the **Plot Settings** section.
- 3 Clear the **Plot dataset edges** checkbox.

Streamline 1

- 1 In the **Model Builder** window, expand the **Mole Fraction, O2, Streamline (fc)** node, then click **Streamline 1**.
- 2 In the **Settings** window for **Streamline**, locate the **Streamline Positioning** section.
- 3 From the **Positioning** list, choose **On selected entities**.
- 4 Locate the **Selection** section. From the **Selection** list, choose **O2 Inlets**.
- 5 Locate the **Coloring and Style** section. Find the **Point style** subsection. From the **Arrow distribution** list, choose **Equal time**.

6 In the **Mole Fraction, O2, Streamline (fc)** toolbar, click  **Plot**.

`I_avg(11)=1 A/cm² Species O2: Streamline: Total flux Streamline Color: Mole fraction (1)`

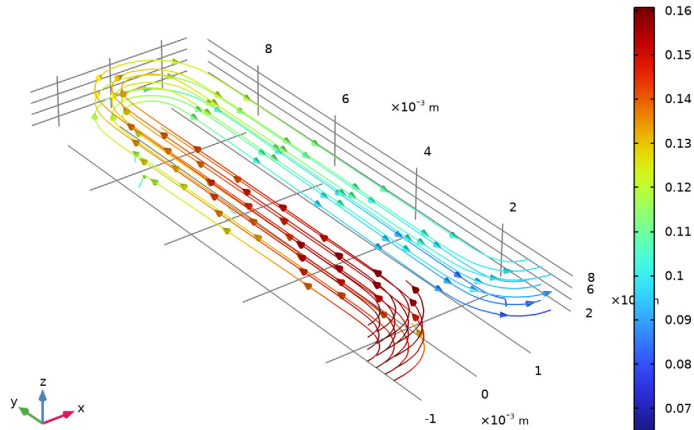

Polarization Plot

- 1 In the **Results** toolbar, click  **ID Plot Group**.
- 2 In the **Settings** window for **ID Plot Group**, type **Polarization Plot** in the **Label** text field.

Global I

- 1 Right-click **Polarization Plot** and choose **Global**.
- 2 In the **Settings** window for **Global**, click **Replace Expression** in the upper-right corner of the **y-Axis Data** section. From the menu, choose **Component I (comp I) > Hydrogen Fuel Cell > fc.phis0_ecl - Electric potential on boundary - V**.

Polarization Plot

- 1 In the **Model Builder** window, click **Polarization Plot**.
- 2 In the **Settings** window for **ID Plot Group**, click to expand the **Title** section.
- 3 From the **Title type** list, choose **None**.
- 4 Locate the **Legend** section. Clear the **Show legends** checkbox.

- 5 In the **Polarization Plot** toolbar, click  **Plot**.

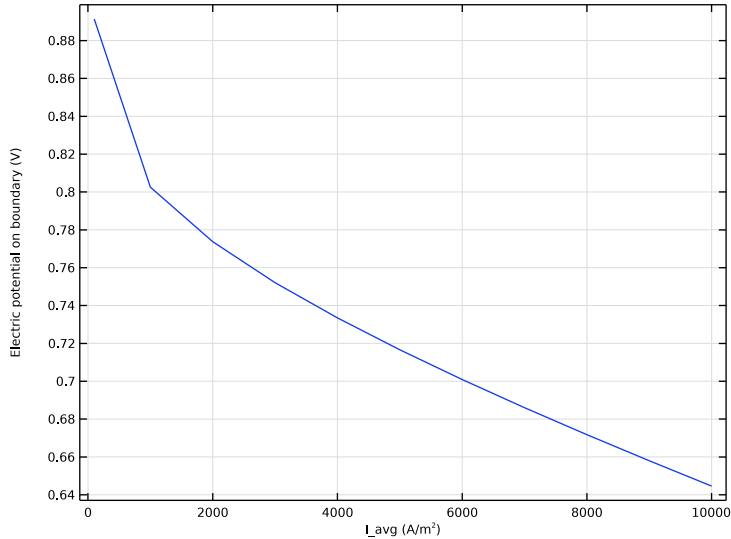

Channel Water Activity

- 1 In the **Results** toolbar, click  **3D Plot Group**.
- 2 In the **Settings** window for **3D Plot Group**, type Channel Water Activity in the **Label** text field.
- 3 Click to expand the **Selection** section. From the **Geometric entity level** list, choose **Boundary**.
- 4 From the **Selection** list, choose **Channels**.
- 5 Locate the **Plot Settings** section. Clear the **Plot dataset edges** checkbox.

Surface I

- 1 Right-click **Channel Water Activity** and choose **Surface**.
- 2 In the **Settings** window for **Surface**, click **Replace Expression** in the upper-right corner of the **Expression** section. From the menu, choose **Component I (comp1) > Hydrogen Fuel Cell > fc.aw - Water activity (relative humidity) - I**.

3 In the **Channel Water Activity** toolbar, click  **Plot**.

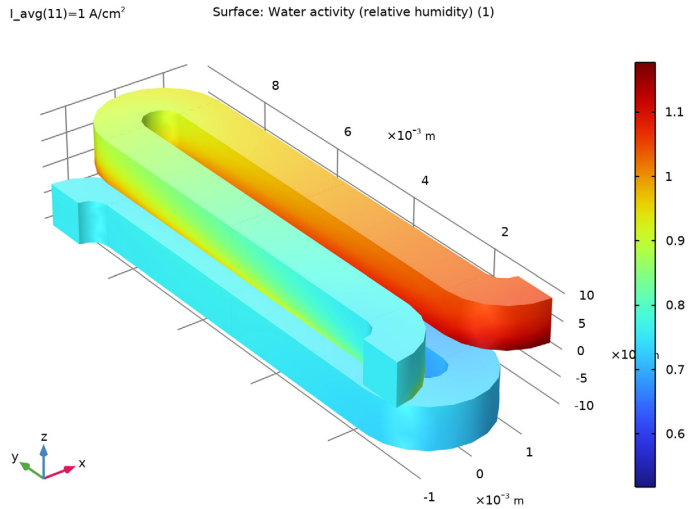

Membrane Water Activity

- 1 In the **Model Builder** window, right-click **Channel Water Activity** and choose **Duplicate**.
- 2 In the **Model Builder** window, click **Channel Water Activity 1**.
- 3 In the **Settings** window for **3D Plot Group**, type Membrane Water Activity in the **Label** text field.
- 4 Locate the **Selection** section. From the **Selection** list, choose **Membrane**.

Surface 1

- 1 In the **Model Builder** window, click **Surface 1**.
- 2 In the **Settings** window for **Surface**, click **Replace Expression** in the upper-right corner of the **Expression** section. From the menu, choose **Component 1 (comp1) > Hydrogen Fuel Cell > Membrane transport > fc.aw_mem - Water activity (relative humidity) - 1**.

3 In the **Membrane Water Activity** toolbar, click  **Plot**.

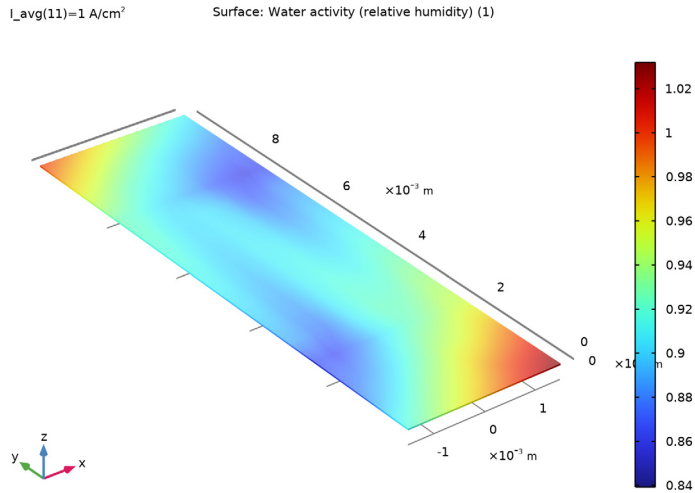

Membrane Conductivity

- 1 In the **Model Builder** window, right-click **Membrane Water Activity** and choose **Duplicate**.
- 2 In the **Settings** window for **3D Plot Group**, type Membrane Conductivity in the **Label** text field.

Surface 1

- 1 In the **Model Builder** window, expand the **Membrane Conductivity** node, then click **Surface 1**.
- 2 In the **Settings** window for **Surface**, click **Replace Expression** in the upper-right corner of the **Expression** section. From the menu, choose **Component 1 (comp1) > Hydrogen Fuel Cell > Electrolyte conductivity - S/m > fc.signalzz - Electrolyte conductivity, zz-component**.

3 In the **Membrane Conductivity** toolbar, click  **Plot**.

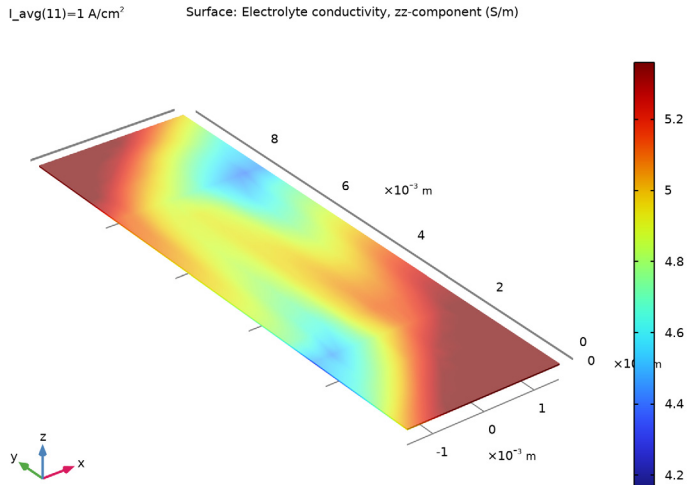

Cross-Membrane Current Density

- 1 In the **Model Builder** window, right-click **Membrane Conductivity** and choose **Duplicate**.
- 2 In the **Settings** window for **3D Plot Group**, type Cross-Membrane Current Density in the **Label** text field.
- 3 Locate the **Selection** section. From the **Selection** list, choose **O2 GDE**.

Surface 1

- 1 In the **Model Builder** window, expand the **Cross-Membrane Current Density** node, then click **Surface 1**.
- 2 In the **Settings** window for **Surface**, click **Replace Expression** in the upper-right corner of the **Expression** section. From the menu, choose **Component 1 (comp1) > Hydrogen Fuel Cell > fc.nll - Normal electrolyte current density - A/m²**.

3 In the **Cross-Membrane Current Density** toolbar, click  **Plot**.

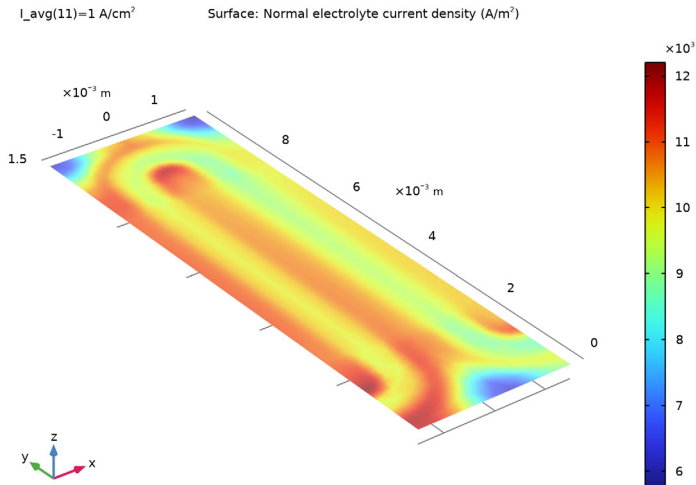

Cross-Membrane Water Flux

- 1 In the **Model Builder** window, right-click **Cross-Membrane Current Density** and choose **Duplicate**.
- 2 In the **Model Builder** window, click **Cross-Membrane Current Density I**.
- 3 In the **Settings** window for **3D Plot Group**, type Cross-Membrane Water Flux in the **Label** text field.

Surface I

- 1 In the **Model Builder** window, click **Surface I**.
- 2 In the **Settings** window for **Surface**, locate the **Expression** section.
- 3 In the **Expression** text field, type `-f.c.r_abs_dsp`.

4 In the **Cross-Membrane Water Flux** toolbar, click  **Plot**.

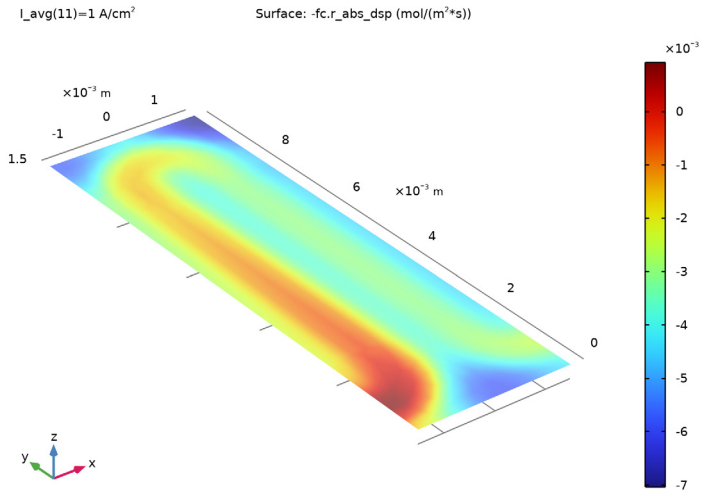

GLOBAL DEFINITIONS

Geometry Parameters

Now that you know the model runs, proceed to solve for the full geometry.

- 1 In the **Model Builder** window, under **Global Definitions** click **Geometry Parameters**.
- 2 In the **Settings** window for **Parameters**, locate the **Parameters** section.
- 3 In the table, enter the following settings:

Name	Expression	Value	Description
W_plate_min	20[mm]	0.02 m	Minimum plate width
N_ch	2	2	Number of channels
N_repeat	2	2	Number of repeating units

GEOMETRY I

- 1 In the **Geometry** toolbar, click  **Build All**.
- 2 Click the  **Zoom Extents** button in the **Graphics** toolbar.

3 In the **Model Builder** window, under **Component 1 (comp1)** click **Geometry 1**.

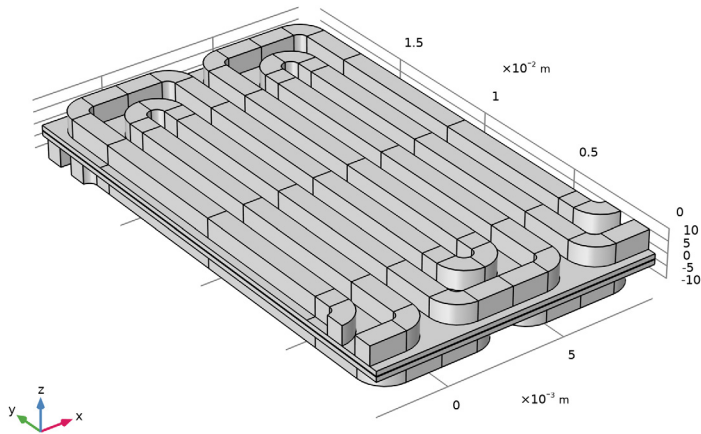

GLOBAL DEFINITIONS

Physics Parameters

- 1 In the **Model Builder** window, under **Global Definitions** click **Physics Parameters**.
- 2 In the **Settings** window for **Parameters**, locate the **Parameters** section.
- 3 In the table, enter the following settings:

Name	Expression	Value	Description
stoich_H2	1.2	1.2	Hydrogen flow stoichiometry
RH_an	25[%]	0.25	Inlet relative humidity, anode side

STUDY 1

Solution 1 (sol1)

Make a copy of the small geometry solution for future reference.

- 1 In the **Model Builder** window, under **Study 1 > Solver Configurations** right-click **Solution 1 (sol1)** and choose **Solution > Copy**.

Solution - Small Geometry

- 1 In the **Model Builder** window, under **Study 1 > Solver Configurations** click **Solution 1 - Copy 1 (sol4)**.
- 2 In the **Settings** window for **Solution**, type **Solution - Small Geometry** in the **Label** text field.

Solver Configurations

Reset the solver sequence in order to generate a solver sequence suitable for the increased geometry size.

Solution 1 (sol1)

- 1 In the **Model Builder** window, expand the **Study 1** node.
- 2 Right-click **Solver Configurations** and choose **Reset Solver to Default**.
- 3 In the **Model Builder** window, expand the **Solution 1 (sol1)** node, then click **Dependent Variables 2**.
- 4 In the **Settings** window for **Dependent Variables**, locate the **General** section.
- 5 From the **Defined by study step** list, choose **User defined**.
The second study step should only solve for pressure variables.
- 6 In the **Model Builder** window, expand the **Study 1 > Solver Configurations > Solution 1 (sol1) > Dependent Variables 2** node, then click **Chemical Potential (comp1.fc.mu0)**.
- 7 In the **Settings** window for **Field**, locate the **General** section.
- 8 Clear the **Solve for this field** checkbox.
- 9 In the **Model Builder** window, click **Electrolyte Potential (comp1.fc.phil)**.
- 10 In the **Settings** window for **Field**, locate the **General** section.
- 11 Clear the **Solve for this field** checkbox.
- 12 In the **Model Builder** window, click **Electric Potential (comp1.fc.phis)**.
- 13 In the **Settings** window for **Field**, locate the **General** section.
- 14 Clear the **Solve for this field** checkbox.
- 15 In the **Model Builder** window, click **Mass Fraction (comp1.fc.wH2O_H2)**.
- 16 In the **Settings** window for **Field**, locate the **General** section.
- 17 Clear the **Solve for this field** checkbox.
- 18 In the **Model Builder** window, click **Mass Fraction (comp1.fc.wH2O_O2)**.
- 19 In the **Settings** window for **Field**, locate the **General** section.

- 20 Clear the **Solve for this field** checkbox.
- 21 In the **Model Builder** window, click **Mass Fraction (comp1.fc.wN2_02)**.
- 22 In the **Settings** window for **Field**, locate the **General** section.
- 23 Clear the **Solve for this field** checkbox.
- 24 In the **Model Builder** window, click **Electric Potential on Boundary (comp1.fc.ecph1.ecl.phis0)**.
- 25 In the **Settings** window for **State**, locate the **General** section.
- 26 Clear the **Solve for this state** checkbox.
- 27 In the **Model Builder** window, click **Boundary Mass Fraction (comp1.fc.h2gasph1.h2in1.wbndH20)**.
- 28 In the **Settings** window for **State**, locate the **General** section.
- 29 Clear the **Solve for this state** checkbox.
- 30 In the **Model Builder** window, click **Boundary Mass Fraction (comp1.fc.o2gasph1.o2in1.wbndH20)**.
- 31 In the **Settings** window for **State**, locate the **General** section.
- 32 Clear the **Solve for this state** checkbox.
- 33 In the **Model Builder** window, click **Boundary Mass Fraction (comp1.fc.o2gasph1.o2in1.wbndN2)**.
- 34 In the **Settings** window for **State**, locate the **General** section.
- 35 Clear the **Solve for this state** checkbox.

All the modified nodes are marked with a small * in the corresponding icon in the model tree. Inspect all subnodes under the **Dependent Variables 2** node and make sure that all nonpressure variables are marked with a (*), and that all 4 pressure variables are left unmodified. (Two of the pressure variables are the pressures on each side of the membrane. The other two pressures are auxiliary variables used to implement the total mass flow rate inlet conditions.)

Step 3: Stationary - All Physics

Plot the channel water activity while solving to monitor the solver progress.

- 1 In the **Model Builder** window, under **Study 1** click **Step 3: Stationary - All Physics**.
- 2 In the **Settings** window for **Stationary**, click to expand the **Results While Solving** section.
- 3 Select the **Plot** checkbox.
- 4 From the **Plot group** list, choose **Channel Water Activity**.

5 In the **Study** toolbar, click  **Compute**.

The larger geometry will take about 10 min to solve.