



# Mass Transport and Electrochemical Reaction in a Fuel Cell Cathode

## Introduction

---

One of the more important aspects of fuel cell modeling is the mass transport through the gas diffusion and reactive layers. Gas concentration gradients may often be quite large and are strongly coupled to the reactions that take place.

Figure 1 shows an example 3D geometry of a cathode from a fuel cell with perforated current collectors. This geometry configuration can be used for self-breathing cathodes or in small experimental cells. Due to the perforation layout, a 3D model is needed in the study of the mass transport, current, and reaction distributions.

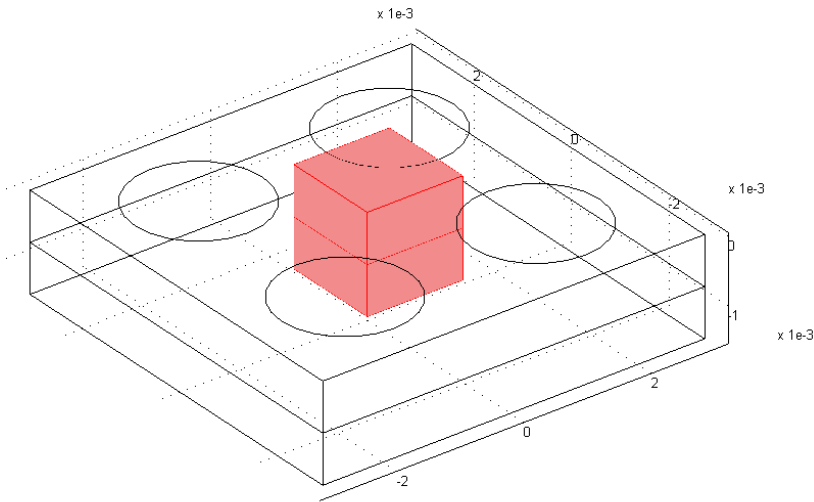
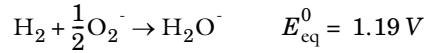

*Figure 1: A fuel cell cathode with a perforated current collector.*

The model couples this mass transport to a concentration-dependent Butler–Volmer electrochemical kinetic expression in a porous gas diffusion electrode (the cathode). Darcy’s law is used to define the convective velocity in the porous gas diffusion electrode, whereas diffusion is modeled using the Maxwell–Stefan equations. A note here is that the molar fractions of the reactants and products, that is, oxygen and water vapor, are typically large ( $>10\%$ ), which makes Fickian diffusion an inappropriate assumption for modeling the diffusive mass transport.

For a more detailed description for how to build this model, including screen shots, see the *Introduction to the Fuel Cell & Electrolyzer Module* book.

The electrochemical reaction for a PEM fuel cell to produce electrical energy is given by:



where  $E_{\text{eq}}^0$  denotes the standard equilibrium potential of the cell reaction, assuming all reactants reacting in the gas phase at atmospheric pressure.

At the anode Hydrogen Oxidation Reaction (HOR) yield protons:

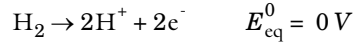

water is produced via Oxygen Reduction Reaction (ORR):

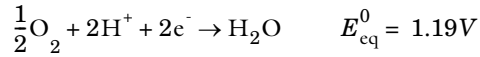

### *Model Definition*

---

Figure 2 shows details for a unit cell, cut out from Figure 1. (In this case, the combination of a circular orifice and square unit cell eliminates the possibility to approximate the geometry with a rotationally symmetric model.) The circular hole in the collector acts as inlet where the gas enters the modeling domain, and at this boundary the gas mixture composition and pressure is known. The upper and lower rectangular domains are the reaction-zone gas diffusion electrodes. They consist of a three-phase porous structure that

contains the feed-gas mixture, an electronically conducting material covered with an electrocatalyst, and an ionically conducting electrolyte.

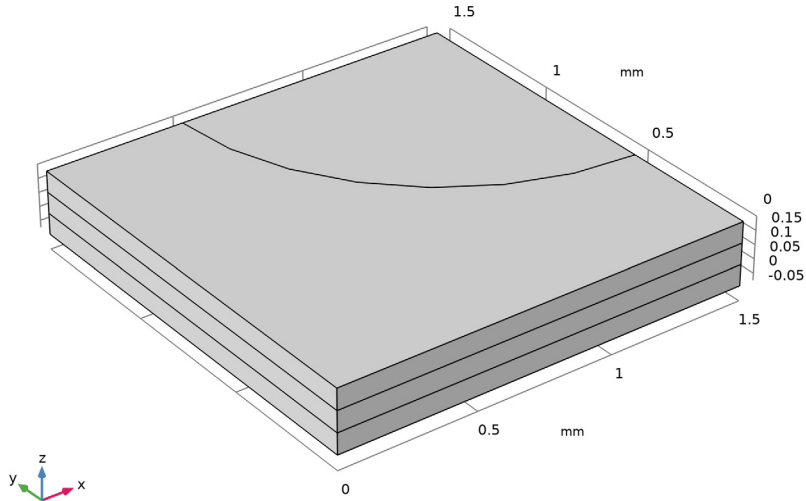

*Figure 2: The modeled fuel cell unit cell. The quarter circle part of the top boundary is the surface of the cathode that is open to the feed gas inlet, while the rest of the top surface sits flush against a metal current collector. In the unit cell, the top domain is the porous cathode, the middle domain is the membrane, and the bottom domain is the porous anode.*

The middle domain corresponds to a solid electrolyte membrane, ionically interconnecting the two electrodes of the fuel cell. No reaction takes place in this domain and the current is conducted ionically. In addition, there are no pores present to allow gas to flow, nor any material present for electronic current conduction.

The gas diffusion electrodes are 0.075 mm thick, as is the electrolyte layer. The unit cell is 1.5-by-1.5 mm in surface, and the gas inlet hole has a radius of 1.0 mm.

The Hydrogen Fuel Cell interface models the electronic and ionic current balances and solves for the potentials  $\phi_s$  and  $\phi_l$  in the electrode and electrolyte phases, respectively. The anode side of the cell is grounded, whereas the current collector boundary at the cathode is set to a cell potential value.

Mass transport and fluid flow are also modeled using the Hydrogen Fuel Cell interface. The species (mass) transport is modeled by the Maxwell–Stefan equations for the mass fractions of oxygen, water and nitrogen in the  $O_2$  gas phase. Mass transport is solved for

in the cathode gas diffusion electrode domain only. Similarly, the pressure and the resulting velocity vector is solved for in the cathode gas diffusion electrode domain only using Darcy's Law. As boundary conditions, inlet molar fractions are set for the three gas species corresponding to a humidified air mixture at 90% relative humidity at atmospheric pressure.

No mass or momentum transport effects are expected to occur at the hydrogen anode side. The partial pressure of hydrogen is set to be constant in the anode domain.

The cell operates at 70°C. Reference equilibrium potentials for the higher temperature, the reference state, for each reaction are calculated automatically by the Hydrogen Fuel Cell interface from the standard free energies of formation ( $\Delta H$ ) and reaction entropies ( $\Delta S$ ) according to

$$E_{\text{eq, ref}}(T) = \frac{(\Delta H - T\Delta S)}{nF}$$

where  $T$  denotes the operating temperature,  $n$  the number of electrons participating in the electrode reaction and  $F$  Faraday's constant.

Generally, the equilibrium potentials of the electrode reactions will depend on the local partial pressures of the reacting species according to the Nernst Equation:

$$E_{\text{eq}} = E_{\text{eq, ref}}(T) - \frac{RT}{nF} \ln \prod_i \left( \frac{p_i}{p_{\text{ref}}} \right)^{\nu_i}$$

where  $\nu_i$  are the stoichiometric coefficients of the reacting species.

The cathode electrode kinetics of the cathode are defined using a Butler-Volmer type of expression according to

$$i_{\text{loc, O}_2} = i_{0, \text{ref, O}_2} \left( \left( \frac{p_{\text{H}_2\text{O}}}{p_{\text{ref}}} \right)^2 \exp\left(\frac{\alpha_{a, \text{O}_2} F \eta_{\text{ref, O}_2}}{RT}\right) - \frac{p_{\text{O}_2}}{p_{\text{ref}}} \exp\left(-\frac{\alpha_{c, \text{O}_2} F \eta_{\text{ref, O}_2}}{RT}\right) \right)$$

where  $p_i$  is the partial pressure of the reacting species,  $p_{\text{ref}} = 1$  atm is the reference pressure and  $\eta_{\text{ref}}$ , the overpotential with respect to the reference state, is defined as

$$\eta_{\text{ref, O}_2} = \phi_s - \phi_l - E_{\text{eq, ref, O}_2}$$

The local current density expression in the cathode is multiplied by a specific area of  $10^9 \text{ m}^2/\text{m}^3$  to create a volumetric current source term in the electrode domain. Assuming ideal kinetics according to the mass action law gives that  $\alpha_{a, \text{O}_2} + \alpha_{c, \text{O}_2} = n$ .

For the anode domain, the kinetics is assumed to be so fast that a linearized Butler–Volmer expression may be used.

$$i_{\text{loc,H2}} = i_{0, \text{ref, H2}} \left( \frac{p_{\text{H2}}}{p_{\text{ref}}} \exp\left(\frac{\alpha_{a, \text{H2}} F \eta_{\text{ref, H2}}}{RT}\right) - \exp\left(-\frac{\alpha_{c, \text{H2}} F \eta_{\text{ref, H2}}}{RT}\right) \right)$$

$$i_{\text{loc,H2}} \approx i_{0, \text{ref, H2}} \left( \frac{p_{\text{H2}}}{p_{\text{ref}}} \right)^{\frac{\alpha_{c, \text{H2}}}{n}} \left( \frac{nF \eta_{\text{H2}}}{RT} \right)$$

assuming  $\alpha_{a, \text{H2}} + \alpha_{c, \text{H2}} = n$ . Also, the local current density expression in the anode is multiplied by a specific area of  $10^9 \text{ m}^2/\text{m}^3$  to create a volumetric current source term in the electrode domain. The overpotential in the anode is defined as

$$\eta_{\text{H2}} = \phi_s - \phi_l - E_{\text{eq, H2}} \quad .$$

In the first part of the model instructions below, a secondary (not concentration dependent) current distribution is modeled. In the second part, mass and momentum transport is incorporated in the  $\text{O}_2$  gas phase mixture (cathode domain), using Maxwell-Stefan diffusion and Darcy’s Law, respectively. In both parts of the tutorial, the model is solved for a range of cell potential values (0.5 V to 1 V in steps of 0.1 V) by the use of an auxiliary sweep in the stationary solver.

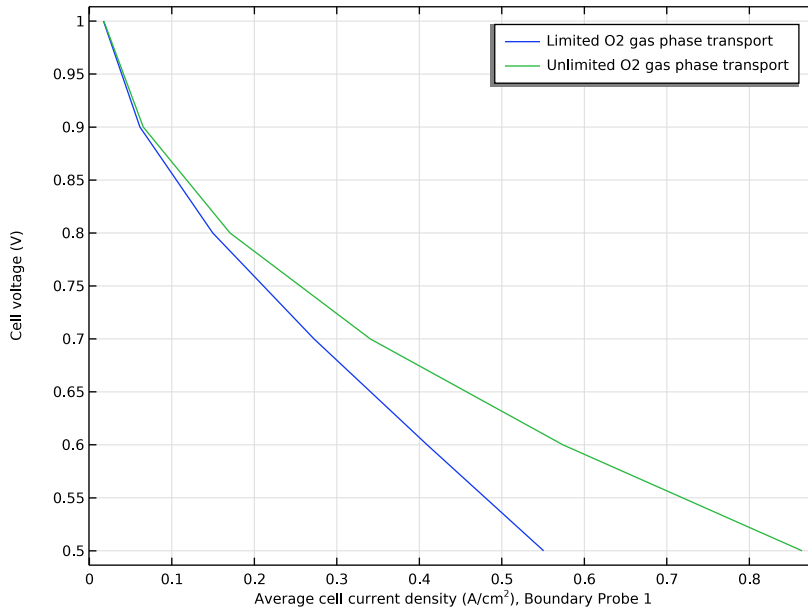
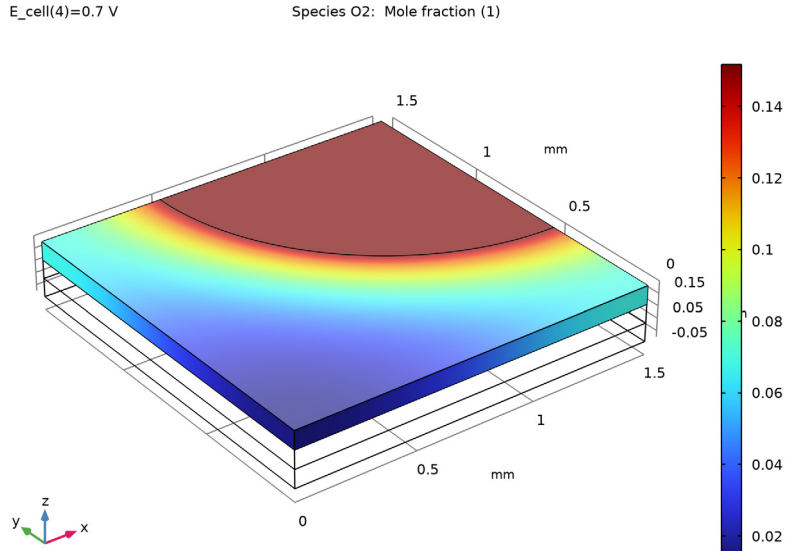

Figure 3: Polarization plot.

Figure 3 shows the polarization plot for the two scenarios investigated: limited and unlimited O<sub>2</sub> gas phase transport. It can be seen that higher average cell current densities are achieved for the unlimited O<sub>2</sub> gas phase transport scenario (that is, when no mass and momentum transport limitations are present).

Note that the plots and discussion in the rest of this section correspond to the limited O<sub>2</sub> gas phase transport scenario, where diffusion and flow (in the cathode domain) has been considered, coupled to charge transport and the electrochemical reactions.

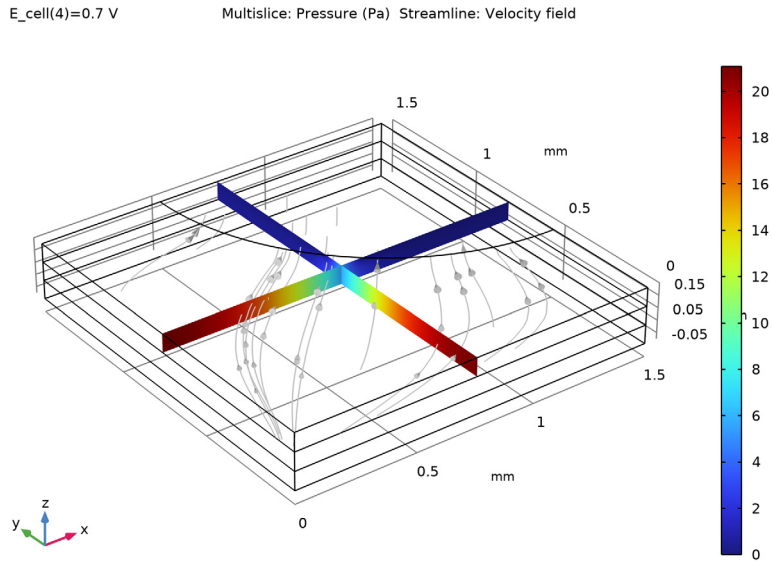

*Figure 4: Mole fraction of oxygen at cell voltage of 0.7 V.*

Figure 4 shows the oxygen mole fraction at cell voltage of 0.7 V. The figure shows that mole fraction variations are small along the thickness of the cathode, while they are substantially larger along the electrode's width.

Figure 5 shows the pressure and gas velocity streamlines in the porous cathode at the same cell voltage. There is a significant velocity peak at the edge of the inlet orifice. This is caused by the contributions of the reactive layer underneath the current collector because in this region the convective flux dominates the mass transport. The gas flows from the interior of the cell toward the circular hole. The reason for this is the oxygen reduction

reaction, with the creation of two water gas molecules, being transported out of the cell, per oxygen molecule entering the cell.

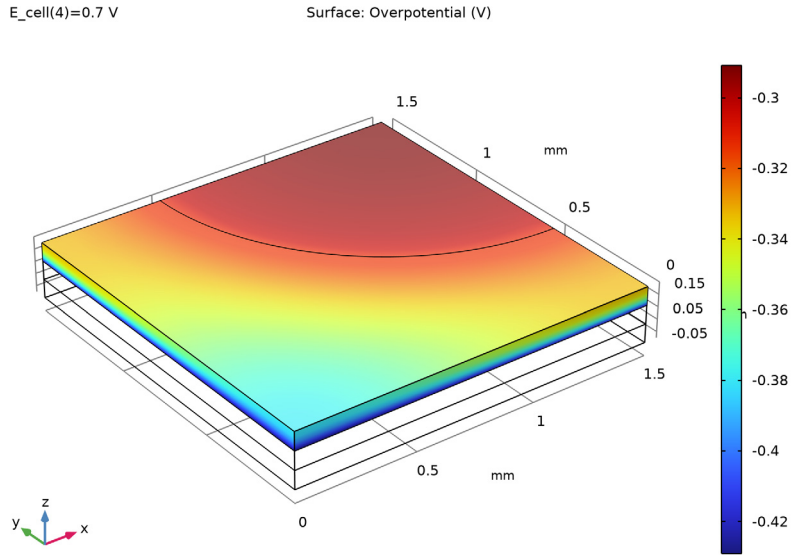

*Figure 5: Pressure and velocity for the gas phase in the cathode's porous reactive layer at cell voltage of 0.7 V.*

The electrochemical reaction rate, represented by the local current density, is related to both the local overvoltage and oxygen concentration in the cathode domain. [Figure 6](#) depicts the local overvoltage (at cell voltage of 0.7 V), which gets more negative toward the electrolyte domain.

The combination of the overpotential and oxygen concentration distributions will result in a highly uneven reaction rate in the reactive layer. One way to study the distribution of

the reaction rate is to plot the ionic current density at the bottom boundary of the membrane layer. [Figure 7](#) shows such a plot at cell voltage of 0.7 V.



*Figure 6: Local overvoltage in the cathode reactive layer at cell voltage of 0.7 V.*

The current-density distribution shows that the variations are rather large. The reaction rate and the current production are higher beneath the orifice and decrease as the distance to the gas inlet increases. This means that the mass transport of reactant dictates the electrode's efficiency for this design at these particular conditions.

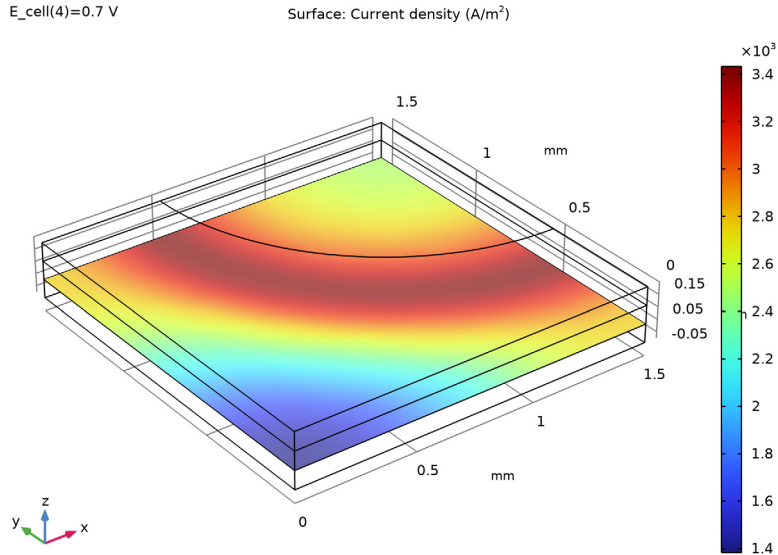

Figure 7: Current density perpendicular to the lower membrane boundary at cell voltage of 0.7 V.

---

**Application Library path:** Fuel\_Cell\_and\_Electrolyzer\_Module/Fuel\_Cells/  
fuel\_cell\_cathode

---

### *Modeling Instructions*

---

From the **File** menu, choose **New**.



#### **NEW**

In the **New** window, click  **Model Wizard**.

#### **MODEL WIZARD**

**1** In the **Model Wizard** window, click  **3D**.

**2** In the **Select Physics** tree, select **Electrochemistry > Hydrogen Fuel Cells > Proton Exchange Membrane (fc)**.

- 3 Click **Add**.
- 4 Click  **Study**.
- 5 In the **Select Study** tree, select **Preset Studies for Selected Physics Interfaces > Stationary with Initialization**.
- 6 Click  **Done**.

## GLOBAL DEFINITIONS

### *Parameters I*

Load some model parameters from a text file.

- 1 In the **Model Builder** window, under **Global Definitions** click **Parameters I**.
- 2 In the **Settings** window for **Parameters**, locate the **Parameters** section.
- 3 Click  **Load from File**.
- 4 Browse to the model's Application Libraries folder and double-click the file `fuel_cell_cathode_parameters.txt`.

## GEOMETRY I

Now draw the model geometry. Use blocks to define the electrolyte and the porous electrode domains. Then use a work plane to draw the inlet hole at the top of the porous electrode. Facilitate geometry selection later (when setting up the physics interfaces) by enabling **Resulting objects selection** and renaming the geometry objects.

- 1 In the **Model Builder** window, under **Component I (comp1)** click **Geometry I**.
- 2 In the **Settings** window for **Geometry**, locate the **Units** section.
- 3 From the **Length unit** list, choose **mm**.

Note that the default length unit should be in **mm**.

### *Membrane*

- 1 In the **Geometry** toolbar, click  **Block**.
- 2 In the **Settings** window for **Block**, type Membrane in the **Label** text field.
- 3 Locate the **Size and Shape** section. In the **Width** text field, type 1.5.
- 4 In the **Depth** text field, type 1.5.
- 5 In the **Height** text field, type 0.075.

- 6 Locate the **Selections of Resulting Entities** section. Select the **Resulting objects selection** checkbox.

By enabling **Resulting objects selection** here, the domain created by this rectangular block will also be available as a named domain option later on when setting up the physics.

#### *Cathode Gas Diffusion Electrode*

- 1 Right-click **Membrane** and choose **Duplicate**.
- 2 In the **Settings** window for **Block**, type Cathode Gas Diffusion Electrode in the **Label** text field.
- 3 Locate the **Position** section. In the **z** text field, type 0.075.

#### *Anode Gas Diffusion Electrode*

- 1 Right-click **Cathode Gas Diffusion Electrode** and choose **Duplicate**.
- 2 In the **Settings** window for **Block**, type Anode Gas Diffusion Electrode in the **Label** text field.
- 3 Locate the **Position** section. In the **z** text field, type -0.075.
- 4 Click  **Build Selected**.

Your geometry should now look like this:

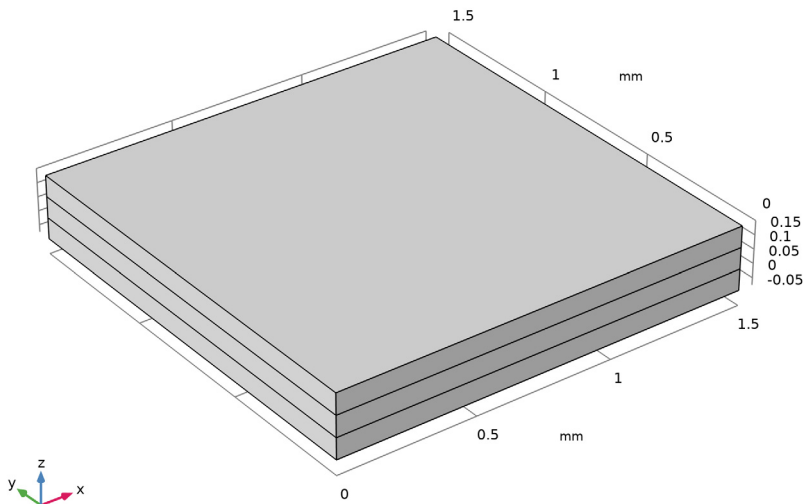

### *Inlet*

Proceed to draw the inlet hole, placed at the top of the cathode gas diffusion electrode block.

- 1 In the **Geometry** toolbar, click  **Work Plane**.
- 2 In the **Settings** window for **Work Plane**, type Inlet in the **Label** text field.
- 3 Locate the **Plane Definition** section. In the **z-coordinate** text field, type 0.15.
- 4 Locate the **Selections of Resulting Entities** section. Select the **Resulting objects selection** checkbox.

### *Inlet (wp1) > Plane Geometry*

In the **Model Builder** window, click **Plane Geometry**.

### *Inlet (wp1) > Circle 1 (c1)*

- 1 In the **Work Plane** toolbar, click  **Circle**.
- 2 In the **Settings** window for **Circle**, locate the **Size and Shape** section.
- 3 In the **Sector angle** text field, type 90.
- 4 Locate the **Position** section. In the **xw** text field, type 1.5.
- 5 In the **yw** text field, type 1.5.
- 6 Locate the **Rotation Angle** section. In the **Rotation** text field, type 180.

7 Click  **Build Selected**.

Your work plane 2D geometry should now contain a quarter of a circle, looking as follows:

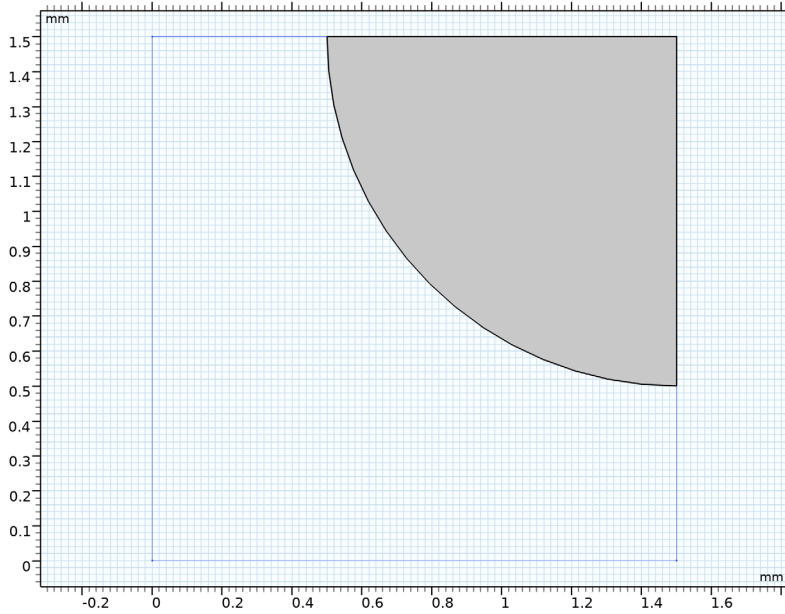

*Form Union (fin)*

1 In the **Geometry** toolbar, click  **Build All**.

2 Click the  **Zoom Extents** button in the **Graphics** toolbar.

The final 3D geometry should now look like this:

- 3 In the **Model Builder** window, under **Component 1 (comp1)** > **Geometry 1** click **Form Union (fin)**.

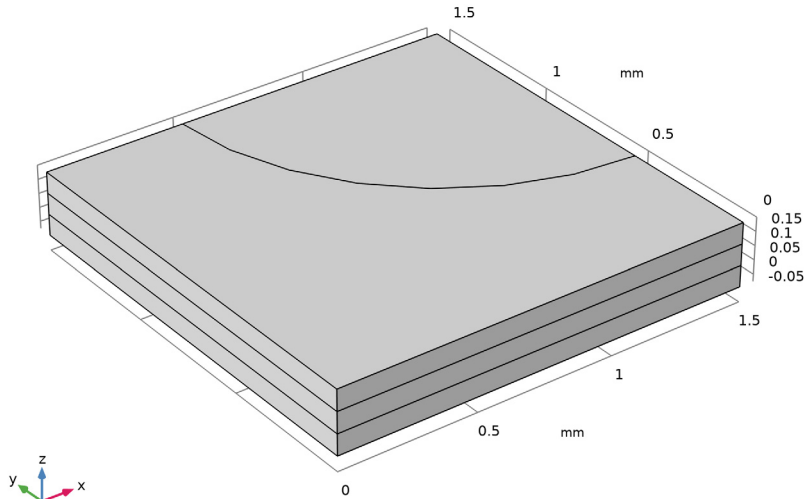

### HYDROGEN FUEL CELL (FC)

In the first part of the tutorial, a secondary (not concentration dependent) current distribution is modeled. Diffusion is hence disabled in the H<sub>2</sub> and O<sub>2</sub> gas phase mixtures. The default gas species are hydrogen and water on the anode side, and oxygen, nitrogen and water on the cathode side.

- 1 In the **Model Builder** window, under **Component 1 (comp1)** click **Hydrogen Fuel Cell (fc)**.
- 2 In the **Settings** window for **Hydrogen Fuel Cell**, locate the **H<sub>2</sub> Gas Mixture** section.
- 3 Find the **Transport mechanisms** subsection. Clear the **Include gas phase diffusion** checkbox.
- 4 Locate the **O<sub>2</sub> Gas Mixture** section. Clear the **Include gas phase diffusion** checkbox.

A number of domain nodes, defining the different phases present in the model were added by default. The active selection of these nodes are locked, but may be controlled by adding additional domain nodes (such as **Membrane** etc). Start by adding these additional nodes, and make the corresponding selections on the geometry.

### *Membrane 1*

- 1 In the **Physics** toolbar, click  **Domains** and choose **Membrane**.
- 2 In the **Settings** window for **Membrane**, locate the **Domain Selection** section.
- 3 From the **Selection** list, choose **Membrane**.

### *H2 Gas Diffusion Electrode 1*

- 1 In the **Physics** toolbar, click  **Domains** and choose **H2 Gas Diffusion Electrode**.
- 2 In the **Settings** window for **H2 Gas Diffusion Electrode**, locate the **Domain Selection** section.
- 3 From the **Selection** list, choose **Anode Gas Diffusion Electrode**.



### *O2 Gas Diffusion Electrode 1*

- 1 In the **Physics** toolbar, click  **Domains** and choose **O2 Gas Diffusion Electrode**.
- 2 In the **Settings** window for **O2 Gas Diffusion Electrode**, locate the **Domain Selection** section.
- 3 From the **Selection** list, choose **Cathode Gas Diffusion Electrode**.

### *Electrolyte Phase 1*

The **Electrolyte Phase** node should now be active on all three domains. Define the conductivity in the **Electrolyte Phase** node by using the **Fuel Cell and Electrolyzer** material library, which contains conductivity data for some common electrolytes.

### **ADD MATERIAL**

- 1 In the **Materials** toolbar, click  **Add Material** to open the **Add Material** window.
- 2 Go to the **Add Material** window.
- 3 In the tree, select **Fuel Cell and Electrolyzer** > **Polymer Electrolytes** > **Nafion®**, EW 1100, Vapor Equilibrated, Protonated.
- 4 Right-click and choose **Add to Component 1 (comp1)**.
- 5 In the **Materials** toolbar, click  **Add Material** to close the **Add Material** window.

### **MATERIALS**

*Nafion®*, EW 1100, Vapor Equilibrated, Protonated (mat1)

Note that the added material by default is active on all domains.

## HYDROGEN FUEL CELL (FC)

### *Electrolyte Phase I*

The polymer electrolyte conductivity depends on the temperature and the relative humidity. Specify the temperature globally in the **Default Model Inputs** node. The temperature defined in the **Default Model Inputs** node may be accessed by multiple physics nodes in the model (for instance in the Nernst and Butler-Volmer equations that will be set later in the **Porous Electrode Reaction** node). Specify the relative humidity for the membrane electrolyte in the **Membrane** node.

## GLOBAL DEFINITIONS

### *Default Model Inputs*

- 1 In the **Model Builder** window, under **Global Definitions** click **Default Model Inputs**.
- 2 In the **Settings** window for **Default Model Inputs**, locate the **Browse Model Inputs** section.
- 3 In the tree, select **General > Temperature (K) - minput.T**.
- 4 Find the **Expression for remaining selection** subsection. In the **Temperature** text field, type T.

## HYDROGEN FUEL CELL (FC)

### *Membrane I*

- 1 In the **Model Builder** window, under **Component I (comp I) > Hydrogen Fuel Cell (fc)** click **Membrane I**.
- 2 In the **Settings** window for **Membrane**, locate the **Electrolyte Water Activity for Material Model Input** section.
- 3 In the  $a_w$  text field, type RH.

Note that you only need to specify the water activity on the **Membrane** node. The water activity in the polymer of the gas diffusion electrodes is approximated to be in equilibrium with the adjacent gas phase in the pores, and is hence automatically set to equal the relative humidity in the gas phase in the **Gas Diffusion Electrode** nodes.

### *H2 Gas Phase I*

The **H2 Gas Phase** node should be active in domain I only.

Set up the composition of the H2 gas phase mixture using the **Humidified mixture** option.

- 1 In the **Model Builder** window, click **H2 Gas Phase I**.
- 2 In the **Settings** window for **H2 Gas Phase**, locate the **Composition** section.
- 3 From the **Mixture specification** list, choose **Humidified mixture**.

4 In the  $RH_{\text{hum}}$  text field, type RH.

5 In the  $T_{\text{hum}}$  text field, type T.

#### *O2 Gas Phase I*

The **O2 Gas Phase** node should be active in domain 3 only.

Similarly, set up the composition of the O2 gas phase mixture using the **Humidified air** option.

1 In the **Model Builder** window, click **O2 Gas Phase I**.

2 In the **Settings** window for **O2 Gas Phase**, locate the **Composition** section.

3 From the **Mixture specification** list, choose **Humidified air**.

4 In the  $RH_{\text{hum}}$  text field, type RH.

5 In the  $T_{\text{hum}}$  text field, type T.

#### *H2 Gas Diffusion Electrode I*

Next set up the properties of the **H2 Gas Diffusion Electrode** node. Note that the electrolyte volume fraction is used to calculate the effective electrolyte conductivity in the porous gas diffusion electrode.

1 In the **Model Builder** window, click **H2 Gas Diffusion Electrode I**.

2 In the **Settings** window for **H2 Gas Diffusion Electrode**, locate the **Electrode Charge Transport** section.

3 In the  $\sigma_s$  text field, type  $\text{sigma}_s$ .

4 Locate the **Effective Electrolyte Charge Transport** section. In the  $\epsilon_1$  text field, type  $\text{eps}_1$ .

#### *H2 Gas Diffusion Electrode Reaction I*

The thermodynamics and kinetics of the hydrogen oxidation reaction are set in the child node that is added by default. Note that the reference equilibrium potential is calculated automatically when the default **Built in** option is used.

1 In the **Model Builder** window, click **H2 Gas Diffusion Electrode Reaction I**.

2 In the **Settings** window for **H2 Gas Diffusion Electrode Reaction**, locate the **Electrode Kinetics** section.

3 From the **Kinetics expression type** list, choose **Linearized Butler-Volmer**.

4 In the  $i_{0,\text{ref}}(T)$  text field, type  $i_{0\_ref\_H2}$ .

5 Locate the **Active Specific Surface Area** section. In the  $a_v$  text field, type  $A_v$ .

#### *O2 Gas Diffusion Electrode I*

Set up the properties of the **O2 Gas Diffusion Electrode** node in the same way.

- 1 In the **Model Builder** window, under **Component 1 (comp1) > Hydrogen Fuel Cell (fc)** click **O2 Gas Diffusion Electrode 1**.
- 2 In the **Settings** window for **O2 Gas Diffusion Electrode**, locate the **Electrode Charge Transport** section.
- 3 In the  $\sigma_s$  text field, type `sigma_s`.
- 4 Locate the **Effective Electrolyte Charge Transport** section. In the  $\epsilon_1$  text field, type `eps_1`.

#### *O2 Gas Diffusion Electrode Reaction 1*

The thermodynamics and kinetics of the oxygen reduction reaction are similarly set in the child node that is added by default. Note that the reference equilibrium potential is calculated automatically when the default **Built in** option is used.

- 1 In the **Model Builder** window, click **O2 Gas Diffusion Electrode Reaction 1**.
- 2 In the **Settings** window for **O2 Gas Diffusion Electrode Reaction**, locate the **Electrode Kinetics** section.
- 3 In the  $i_{0,\text{ref}}(T)$  text field, type `i0_ref_02`.
- 4 Locate the **Active Specific Surface Area** section. In the  $a_v$  text field, type `Av`.

Finalize the secondary current distribution model by setting up the boundary conditions for the potentials in the electronic conducting phase.

#### *Electronic Conducting Phase 1*

In the **Model Builder** window, under **Component 1 (comp1) > Hydrogen Fuel Cell (fc)** click **Electronic Conducting Phase 1**.

#### *Electric Ground 1*

- 1 In the **Physics** toolbar, click  **Attributes** and choose **Electric Ground**.
- 2 Select Boundary 3 only.

#### *Electronic Conducting Phase 1*

In the **Model Builder** window, click **Electronic Conducting Phase 1**.

#### *Electric Potential 1*

- 1 In the **Physics** toolbar, click  **Attributes** and choose **Electric Potential**.
- 2 Select Boundary 10 only.
- 3 In the **Settings** window for **Electric Potential**, locate the **Electric Potential** section.
- 4 In the  $\phi_{s,\text{bnd}}$  text field, type `E_cell`.

## MESH 1

The default mesh that will be used automatically is fairly coarse, featuring only one or two mesh elements in the  $z$  direction. To improve accuracy of the results, the mesh needs to be refined. For this geometry a swept mesh can be used to get accurate control of the number of elements in the  $z$  direction. Inspect the default mesh before refining it.

- 1 In the **Model Builder** window, under **Component 1 (comp1)** right-click **Mesh 1** and choose **Build All**.

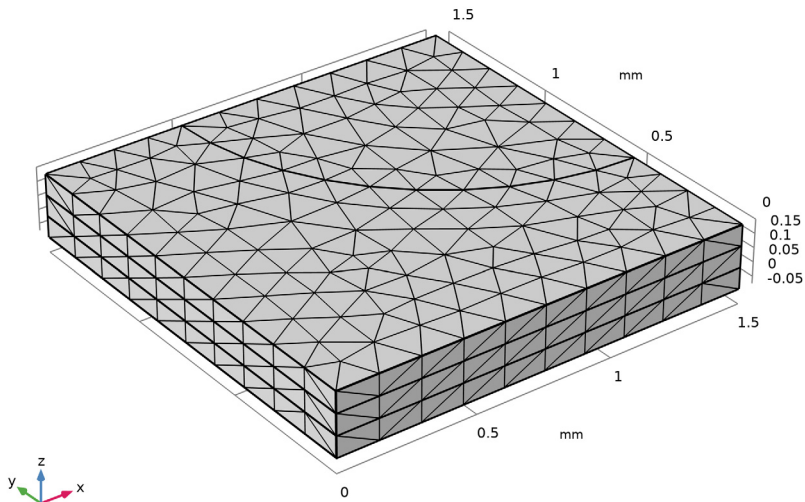

- 2 In the **Settings** window for **Mesh**, locate the **Physics-Controlled Mesh** section.
- 3 From the **Element size** list, choose **Fine**.

### *Swept 1*

- 1 In the **Mesh** toolbar, click  **Swept**.
- 2 In the **Settings** window for **Swept**, click to expand the **Source Faces** section.
- 3 Select Boundaries 10 and 14 only.

### *Distribution 1*

- 1 Right-click **Swept 1** and choose **Distribution**.
- 2 In the **Settings** window for **Distribution**, locate the **Domain Selection** section.
- 3 From the **Selection** list, choose **Cathode Gas Diffusion Electrode**.

- 4 Locate the **Distribution** section. From the **Distribution type** list, choose **Predefined**.  
We will create a mesh with thinner elements in the cathode gas diffusion electrode domain toward the boundary facing the membrane domain.
- 5 In the **Element ratio** text field, type 5.
- 6 Select the **Reverse direction** checkbox.
- 7 Click  **Build All**.

The mesh should now look as follows:

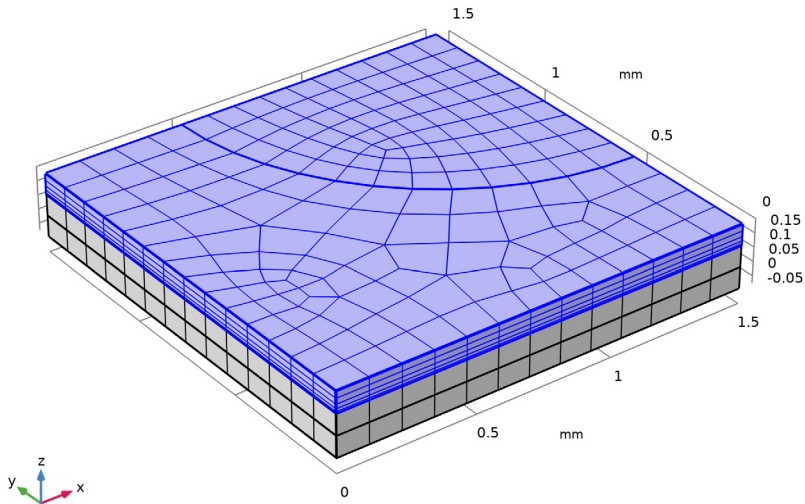

### *Swept 1*

To improve the resolution along the current collector-inlet hole edge, and the interior of the electrode, also add some **Size** nodes.

### *Size 1*

- 1 In the **Model Builder** window, right-click **Swept 1** and choose **Size**.
- 2 In the **Settings** window for **Size**, locate the **Geometric Entity Selection** section.
- 3 From the **Geometric entity level** list, choose **Edge**.
- 4 Select Edge 19 only.
- 5 Locate the **Element Size** section. From the **Predefined** list, choose **Extra fine**.

### Size 2

- 1 Right-click **Swept 1** and choose **Size**.
- 2 In the **Settings** window for **Size**, locate the **Geometric Entity Selection** section.
- 3 From the **Geometric entity level** list, choose **Edge**.
- 4 Select Edges 10 and 11 only.
- 5 Locate the **Element Size** section. From the **Predefined** list, choose **Finer**.

### Size 3

- 1 Right-click **Swept 1** and choose **Size**.
- 2 In the **Settings** window for **Size**, locate the **Geometric Entity Selection** section.
- 3 From the **Geometric entity level** list, choose **Point**.
- 4 Select Point 4 only.
- 5 Locate the **Element Size** section. From the **Predefined** list, choose **Extra fine**.
- 6 Click  **Build All**.

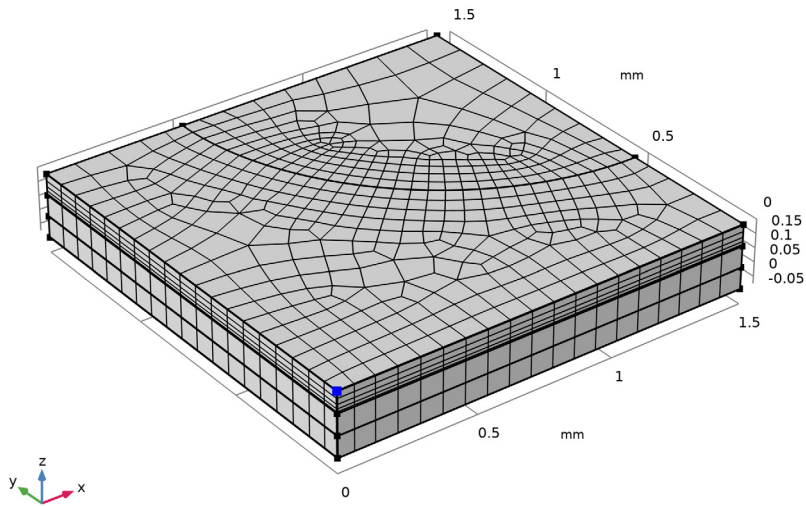

## STUDY 1

The settings for the secondary current distribution model are now complete.

- 1 In the **Study** toolbar, click  **Compute**.

## RESULTS

### *Electrode Potential with Respect to Ground (fc)*

Inspect the default plots.

1 In the **Electrode Potential with Respect to Ground (fc)** toolbar, click  **Plot**.

The electrode potential plot should look as follows:

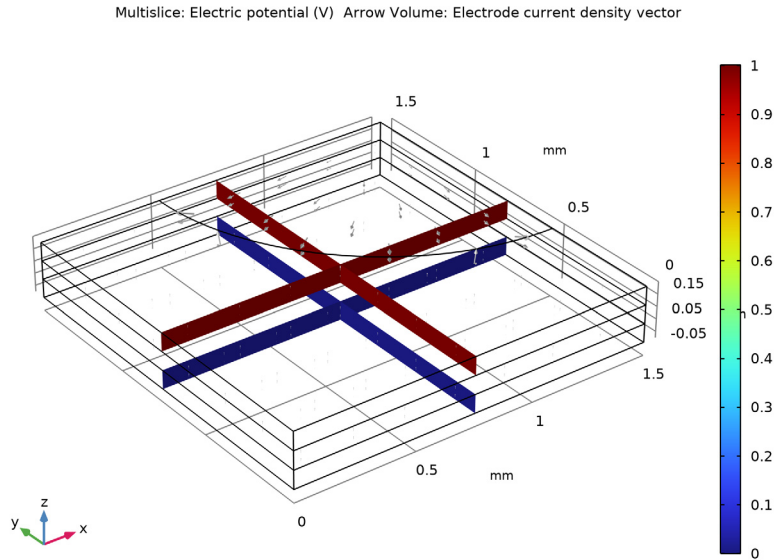

## DEFINITIONS

We will now compute and plot a polarization curve, that is, solve for a range of cell potentials, and plot these versus the average cell current density. First introduce a boundary probe for the average cell current density at the anode gas diffusion electrode boundary.

### *Boundary Probe 1 (bnd1)*

1 In the **Definitions** toolbar, click  **Probes** and choose **Boundary Probe**.

2 Select Boundary 3 only.

3 In the **Settings** window for **Boundary Probe**, click **Replace Expression** in the upper-right corner of the **Expression** section. From the menu, choose **Component 1 (comp1) > Hydrogen Fuel Cell > fc.nls - Normal electrode current density - A/m<sup>2</sup>**.

Change the sign of the expression.

- 4 Locate the **Expression** section. In the **Expression** text field, type `-f.c.nIs`.
- 5 In the **Table and plot unit** field, type `A/cm^2`.
- 6 Select the **Description** checkbox. In the associated text field, type `Average cell current density`.

## STUDY 1

### *Step 2: Stationary*

Set up an auxiliary sweep to solve for a range of cell potential values and compute the model again.

- 1 In the **Model Builder** window, under **Study 1** click **Step 2: Stationary**.
- 2 In the **Settings** window for **Stationary**, click to expand the **Study Extensions** section.
- 3 Select the **Auxiliary sweep** checkbox.
- 4 Click **+ Add**.
- 5 In the table, enter the following settings:

Parameter name	Parameter value list	Parameter unit
E_cell (Cell voltage)	range(1, -0.1, 0.5)	V

- 6 In the **Study** toolbar, click **= Compute**.

## RESULTS

### *Polarization Curve*

A probe plot for the average current density was now created by default. Modify it as follows:

- 1 In the **Model Builder** window, under **Results** click **Probe Plot Group 3**.
- 2 In the **Settings** window for **ID Plot Group**, type `Polarization Curve` in the **Label** text field.
- 3 Locate the **Plot Settings** section. Select the **Flip the x- and y-axes** checkbox.
- 4 Select the **y-axis label** checkbox. In the associated text field, type `Cell voltage (V)`.

5 In the **Polarization Curve** toolbar, click  **Plot**.

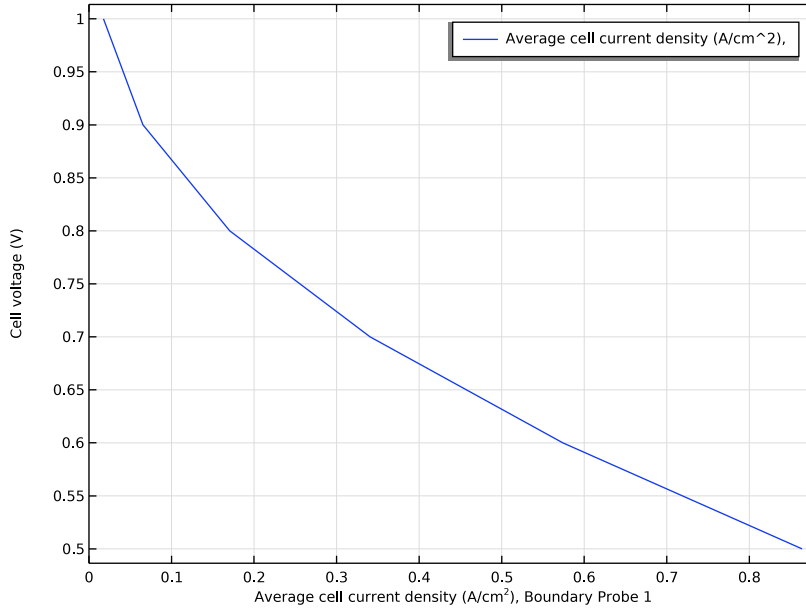

### HYDROGEN FUEL CELL (FC)

Now we start the second part of the tutorial to incorporate mass and momentum transport. Include mass transport using Maxwell-Stefan diffusion and momentum transport using Darcy's Law in the O<sub>2</sub> gas phase mixture.

- 1 In the **Model Builder** window, under **Component 1 (comp1)** click **Hydrogen Fuel Cell (fc)**.
- 2 In the **Settings** window for **Hydrogen Fuel Cell**, locate the **O<sub>2</sub> Gas Mixture** section.
- 3 Find the **Transport mechanisms** subsection. Select the **Include gas phase diffusion** checkbox.
- 4 Select the **Use Darcy's Law for momentum transport** checkbox.

#### *O<sub>2</sub> Gas Phase 1*

Inspect the settings of the **O<sub>2</sub> Gas Phase** node. Note that since you are now including diffusion in the model, the composition values you specified earlier are no longer visible. (Settings for Diffusion are now present instead.) The initial and inlet conditions (composition and pressure) of the O<sub>2</sub> gas phase mixture are now specified using child nodes. The gas composition is specified using the **Humidified air** option.

Set up the initial and inlet conditions (composition and pressure) of the O<sub>2</sub> gas phase mixture.

#### *Initial Values 1*

- 1 In the **Model Builder** window, click **Initial Values 1**.
- 2 In the **Settings** window for **Initial Values**, locate the **Initial Composition** section.
- 3 From the **Mixture specification** list, choose **Humidified air**.
- 4 In the  $RH_{\text{hum}}$  text field, type RH.
- 5 In the  $T_{\text{hum}}$  text field, type T.

#### *O<sub>2</sub> Gas Phase 1*

The same parameter values that were used for the initial values are used to specify the inlet mole fractions.

- 1 In the **Model Builder** window, click **O<sub>2</sub> Gas Phase 1**.

#### *O<sub>2</sub> Inlet 1*

- 1 In the **Physics** toolbar, click  **Attributes** and choose **O<sub>2</sub> Inlet**.
- 2 In the **Settings** window for **O<sub>2</sub> Inlet**, locate the **Boundary Selection** section.
- 3 From the **Selection** list, choose **Inlet**.

#### *O<sub>2</sub> Gas Diffusion Electrode 1*

Finally, set up the gas transport properties in the **O<sub>2</sub> Gas Diffusion Electrode** node.

- 1 In the **Model Builder** window, under **Component 1 (comp 1) > Hydrogen Fuel Cell (fc)** click **O<sub>2</sub> Gas Diffusion Electrode 1**.
- 2 In the **Settings** window for **O<sub>2</sub> Gas Diffusion Electrode**, locate the **Gas Transport** section.
- 3 In the  $\epsilon_g$  text field, type eps\_gas.
- 4 In the  $\kappa_g$  text field, type perm.

Note that the effect of varying concentration is automatically taken into account in the built-in thermodynamic and kinetic expressions of the oxygen reduction reaction in the **O<sub>2</sub> Gas Diffusion Electrode Reaction** child node, and appropriate mass sources resulting from the electrochemical reaction in the O<sub>2</sub> gas phases mixture are automatically defined. Hence, no additional settings are required in this node.

## **RESULTS**

Before proceeding to solve the model with transport effects, duplicate the probe table and rename the copy appropriately.

### *Unlimited O<sub>2</sub> gas phase transport*

- 1 In the **Model Builder** window, expand the **Results > Tables** node.
- 2 Right-click **Probe Table 1** and choose **Duplicate**.
- 3 In the **Settings** window for **Table**, type Unlimited O<sub>2</sub> gas phase transport in the **Label** text field.

### **STUDY 1**

In order to generate new default plots related to the introduced mass transport, remove the old study sequence before recomputing.

### *Solver Configurations*

- 1 In the **Model Builder** window, under **Study 1** right-click **Solver Configurations** and choose **Delete Configurations**.
- 2 In the **Home** toolbar, click  **Compute**.

### **RESULTS**

#### *Polarization Curve*

Modify the **Polarization Curve** as follows to compare the concentration independent and concentration dependent solutions.

#### *Probe Table Graph: Limited O<sub>2</sub> gas phase transport*

- 1 In the **Model Builder** window, expand the **Polarization Curve** node, then click **Probe Table Graph 1**.
- 2 In the **Settings** window for **Table Graph**, type Probe Table Graph: Limited O<sub>2</sub> gas phase transport in the **Label** text field.
- 3 Click to expand the **Legends** section. From the **Legends** list, choose **Manual**.
- 4 In the table, enter the following settings:

---

<b>Legends</b>
Limited O <sub>2</sub> gas phase transport

---

#### *Probe Table Graph: Unlimited O<sub>2</sub> gas phase transport*

- 1 Right-click **Probe Table Graph: Limited O<sub>2</sub> gas phase transport** and choose **Duplicate**.
- 2 In the **Settings** window for **Table Graph**, type Probe Table Graph: Unlimited O<sub>2</sub> gas phase transport in the **Label** text field.
- 3 Locate the **Data** section. From the **Table** list, choose **Unlimited O<sub>2</sub> gas phase transport**.

4 Locate the **Legends** section. In the table, enter the following settings:

---

**Legends**

---

Unlimited O2 gas phase transport

---

*Polarization Curve*

1 In the **Model Builder** window, click **Polarization Curve**.

2 In the **Polarization Curve** toolbar, click  **Plot**.

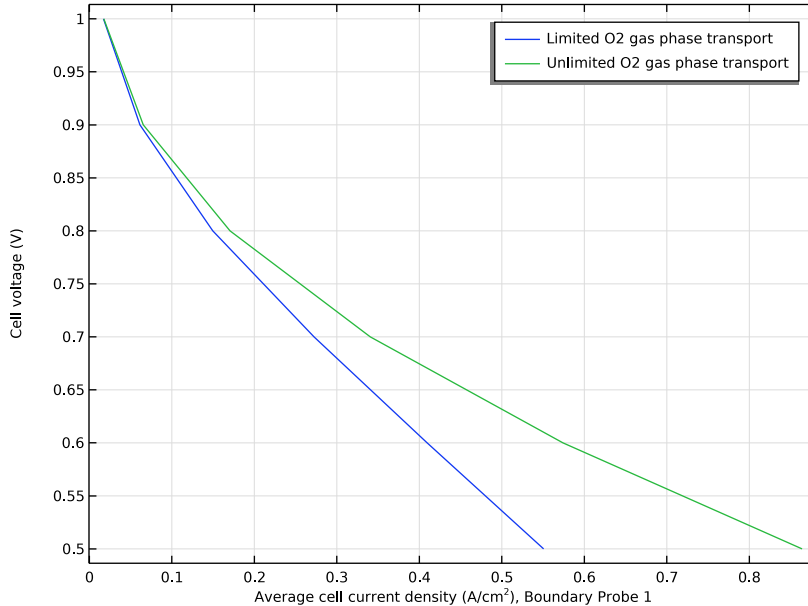

*Mole Fraction, O2, Streamline (fc)*

The mole fractions of the different species are plotted by default at the cell potential of 0.5 V. Modify the O2 plots as follows to plot at the cell potential of 0.7 V.

1 In the **Model Builder** window, click **Mole Fraction, O2, Streamline (fc)**.

2 In the **Settings** window for **3D Plot Group**, locate the **Data** section.

3 From the **Parameter value (E<sub>cell</sub> (V))** list, choose **0.7**.

E<sub>cell</sub>(4)=0.7 V    Species O<sub>2</sub>: Streamline: Total flux    Streamline Color: Mole fraction (1)

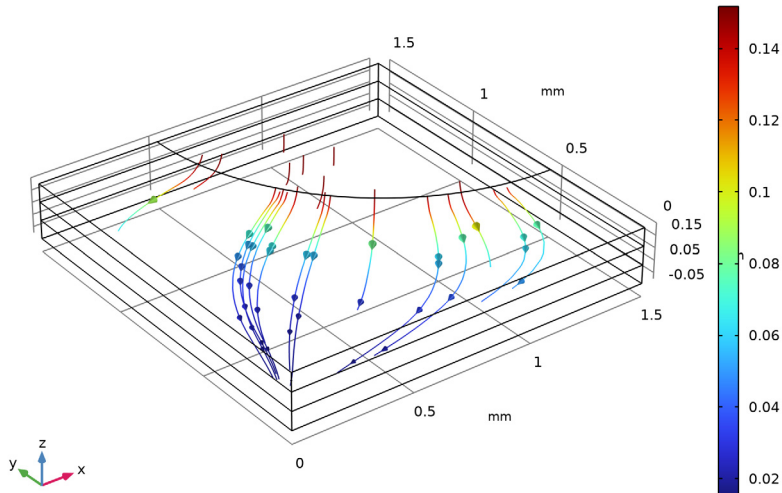

Note the direction of the arrows. Oxygen flows from the inlet hole into the porous cathode to react to form water.

*Mole Fraction, O<sub>2</sub>, Surface (fc)*

- 1 In the **Model Builder** window, click **Mole Fraction, O<sub>2</sub>, Surface (fc)**.
- 2 In the **Settings** window for **3D Plot Group**, locate the **Data** section.

3 From the **Parameter value (E<sub>cell</sub> (V))** list, choose **0.7**.

E<sub>cell</sub>(4)=0.7 V

Species O2: Mole fraction (1)

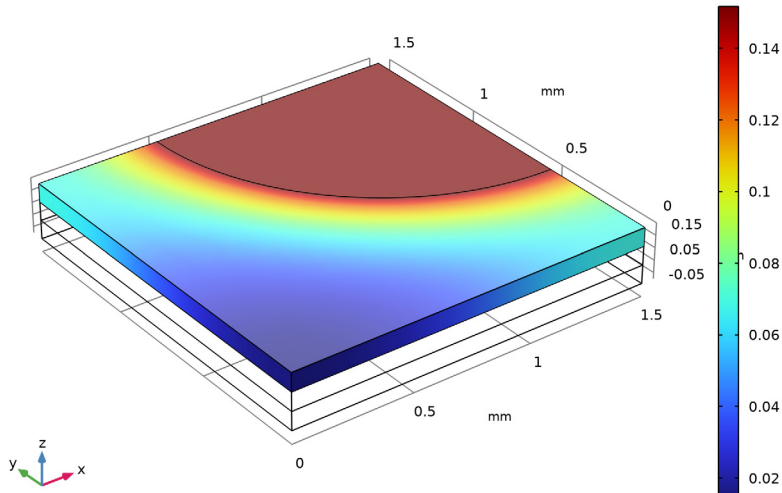

The oxygen mole fraction gets low far away from the inlet hole.

*Pressure (fc)*

The Darcy pressure with velocity streamlines is also plotted by default at the cell potential of 0.5 V. Modify as follows to plot at the cell potential of 0.7 V.

- 1 In the **Model Builder** window, click **Pressure (fc)**.
- 2 In the **Settings** window for **3D Plot Group**, locate the **Data** section.

**3** From the **Parameter value (E<sub>cell</sub> (V))** list, choose **0.7**.

E<sub>cell</sub>(4)=0.7 V

Multislice: Pressure (Pa) Streamline: Velocity field

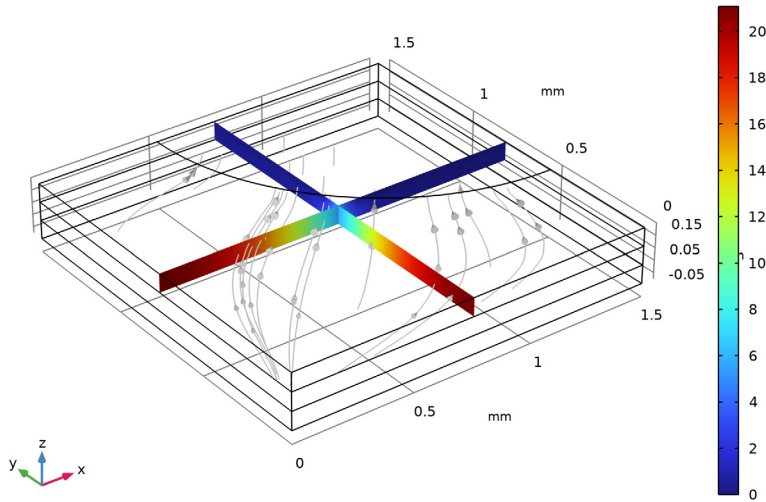

The direction of the net velocity is toward the inlet hole, that is, opposite to the oxygen flux. This is a result of the production of two water molecules per consumed oxygen molecule in the cathode.

Finally, create some additional plots for the activation overpotential and local volumetric current density in the cathode gas diffusion electrode, and the current density at the anode gas diffusion electrode boundary.

*Overpotential in Cathode*

**1** In the **Results** toolbar, click  **3D Plot Group**.

**2** In the **Settings** window for **3D Plot Group**, type **Overpotential in Cathode** in the **Label** text field.

**3** Locate the **Data** section. From the **Parameter value (E<sub>cell</sub> (V))** list, choose **0.7**.

*Surface I*

**1** Right-click **Overpotential in Cathode** and choose **Surface**.

**2** In the **Settings** window for **Surface**, click **Replace Expression** in the upper-right corner of the **Expression** section. From the menu, choose **Component I (comp1) > Hydrogen Fuel Cell > Electrode kinetics > fc.eta\_o2gderI - Overpotential - V**.

3 In the **Overpotential in Cathode** toolbar, click  **Plot**.

$E_{\text{cell}(4)}=0.7 \text{ V}$

Surface: Overpotential (V)

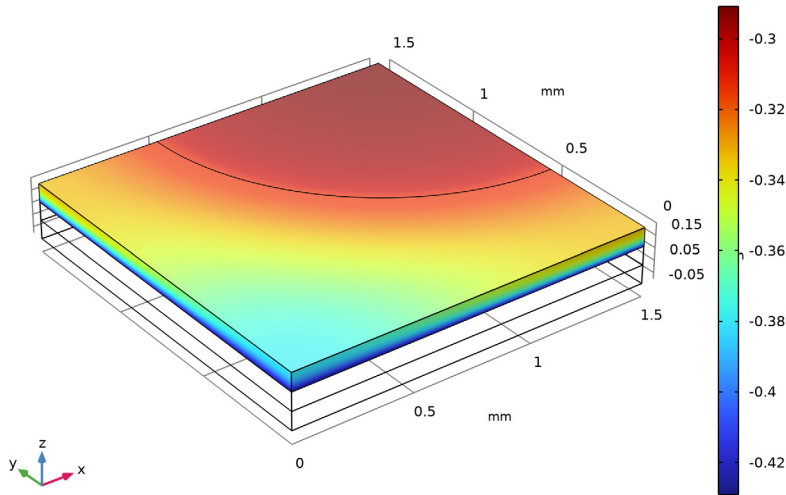

Generally the highest overpotentials (in magnitude) are found in the region facing the **Membrane** domain. Since the overpotential is the driving force for the electrochemical reactions, this is the region where we can expect higher reaction rates.

#### *Local Volumetric Current Density in Cathode*

- 1 In the **Results** toolbar, click  **3D Plot Group**.
- 2 In the **Settings** window for **3D Plot Group**, type Local Volumetric Current Density in Cathode in the **Label** text field.
- 3 Locate the **Data** section. From the **Parameter value ( $E_{\text{cell}}$  (V))** list, choose **0.7**.

#### *Surface I*

- 1 Right-click **Local Volumetric Current Density in Cathode** and choose **Surface**.
- 2 In the **Settings** window for **Surface**, click **Replace Expression** in the upper-right corner of the **Expression** section. From the menu, choose **Component I (comp1)** > **Hydrogen Fuel Cell > Electrode kinetics > fc.iv\_o2gderI - Local current source - A/m<sup>3</sup>**.

- 3 In the **Local Volumetric Current Density in Cathode** toolbar, click  **Plot**.

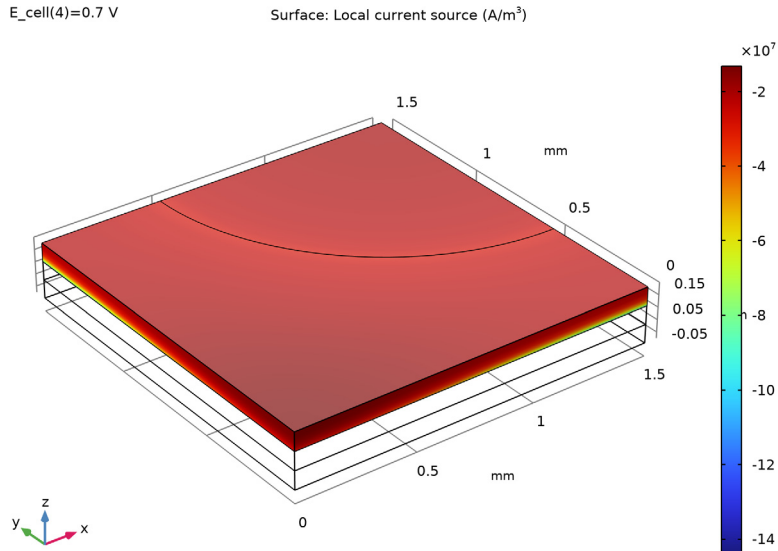

As for the overpotentials, the highest current density magnitudes are found close to the **Membrane** domain.

#### *Current Density at Anode Boundary*

- 1 In the **Results** toolbar, click  **3D Plot Group**.
- 2 In the **Settings** window for **3D Plot Group**, type Current Density at Anode Boundary in the **Label** text field.
- 3 Locate the **Data** section. From the **Parameter value (E\_cell (V))** list, choose **0.7**.
- 4 Click to expand the **Selection** section. From the **Geometric entity level** list, choose **Boundary**.
- 5 Select Boundary 6 only.

#### *Surface I*

- 1 Right-click **Current Density at Anode Boundary** and choose **Surface**.
- 2 In the **Settings** window for **Surface**, click **Replace Expression** in the upper-right corner of the **Expression** section. From the menu, choose **Component I (comp1) > Hydrogen Fuel Cell > fc.nll - Normal electrolyte current density - A/m<sup>2</sup>**.

- 3 Locate the **Expression** section. In the **Expression** text field, type `abs(fc.nI1)`.  
The `abs()` is an operator which will return the absolute (positive) value of the argument.
- 4 Select the **Description** checkbox. In the associated text field, type `Current density`.
- 5 In the **Current Density at Anode Boundary** toolbar, click  **Plot**.

$E_{\text{cell}(4)} = 0.7 \text{ V}$

Surface: Current density ( $\text{A/m}^2$ )

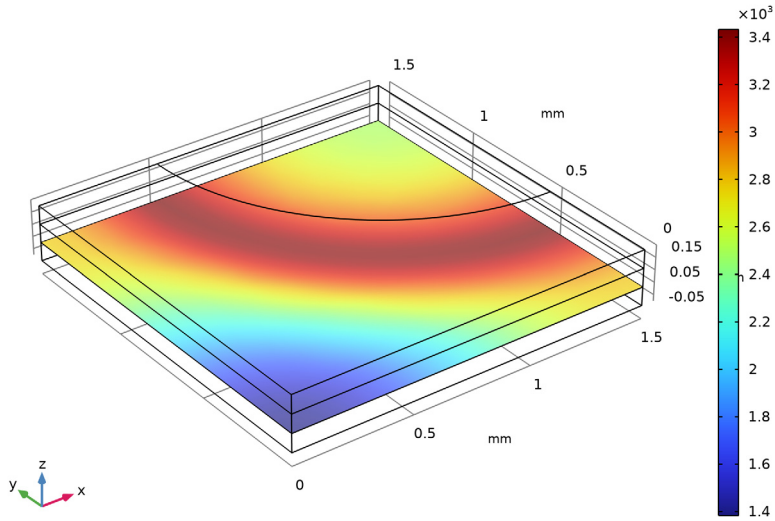

The region of highest current densities is located below the quarter circular edge of the inlet hole. In this area the combined effects of the ohmic and mass transfer losses in the gas diffusion electrode are at a minimum.

