



Shunt Currents in an Alkaline Electrolyzer Stack

Introduction

In an alkaline electrolyzer stack, all cells share the same electrolyte. As a result of all cells being in ionic contact, parasitic shunt currents flow between the cells through the manifolds and the electrolyte channels, on both the inlet and outlet side.

This example models a secondary current distribution in a stack comprising 20 cells. The electricity-to-hydrogen coulombic and energy efficiencies for the stack are computed, as well as the individual shunt currents entering or exiting each cell.

Model Definition

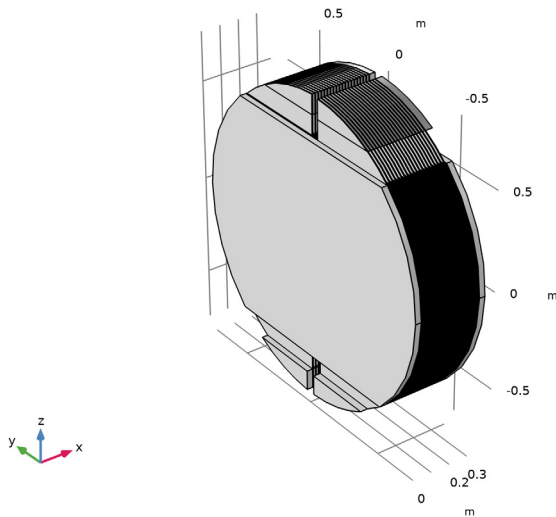

Figure 1: Model stack geometry.

[Figure 1](#) shows the full model geometry. The stack consists of two end plates and 20 repeating unit cells, shown in [Figure 2](#).

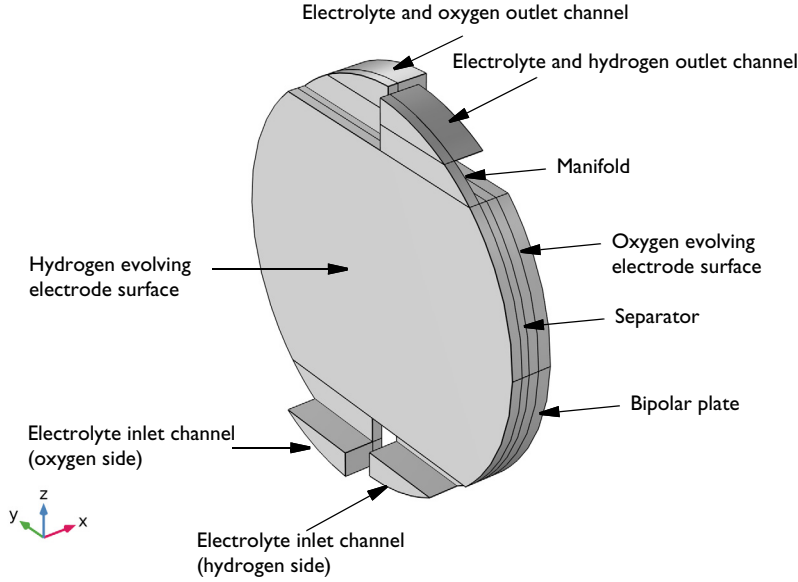

Figure 2: Repeating cell unit. Scaled ten times in the x direction.

The end plates and the bipolar plates are made of steel. The electrolyte is 6 M KOH.

The model is set up using the **Water Electrolyzer** interface. The electrode surfaces are modeled using Butler–Volmer kinetics and ohmic losses both in the electrode and electrolyte phases are included, but any effects due to gas phase mass transport limitations are neglected (this is also known as a secondary current distribution model). The model is isothermal, with the stack set to operate at 85°C.

The effective electrolyte conductivity in the electrolyte compartment on each side of the separate is set to depend on the electrolyte volume fraction according to

$$\sigma_{l, \text{eff}} = \varepsilon_l^{3/2} \sigma_{l, \text{bulk}} \quad (1)$$

where $\sigma_{l, \text{bulk}}$ is the bulk conductivity of 6.0 KOH. Due to gas evolution in the cell electrolyte compartments, the electrolyte volume fraction ε_l is defined to vary linearly with z from 100% at the bottom of the electrode active surface area to 50% at the exit to the upper manifolds.

The model is solved using an auxiliary sweep, sweeping the average cell voltage from 1.3 V to 1.8 V.

Results and Discussion

Figure 3 shows the electric potential in the end plates and bipolar plates of the stack for an average cell voltage of 1.8 V.

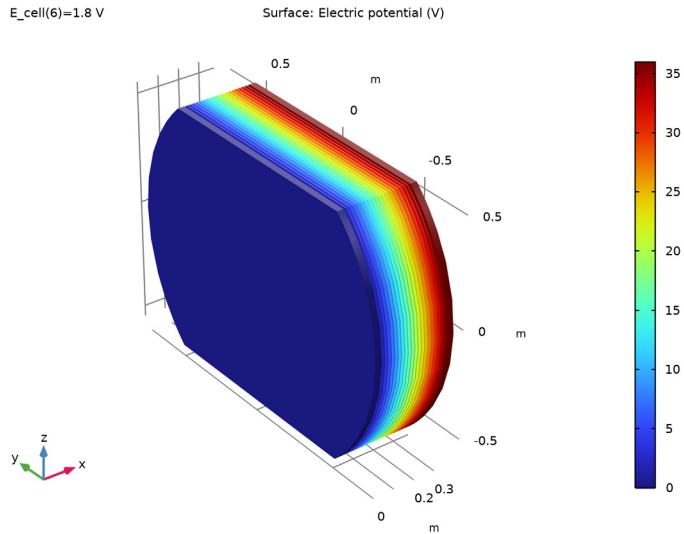

Figure 3: Electrode phase potential.

Figure 4 and Figure 5 show the electrolyte phase potential in the stack, and the corresponding electrolyte current streamlines in the inlet/outlet channels and manifolds, for an average cell voltage of 1.8 V, respectively.

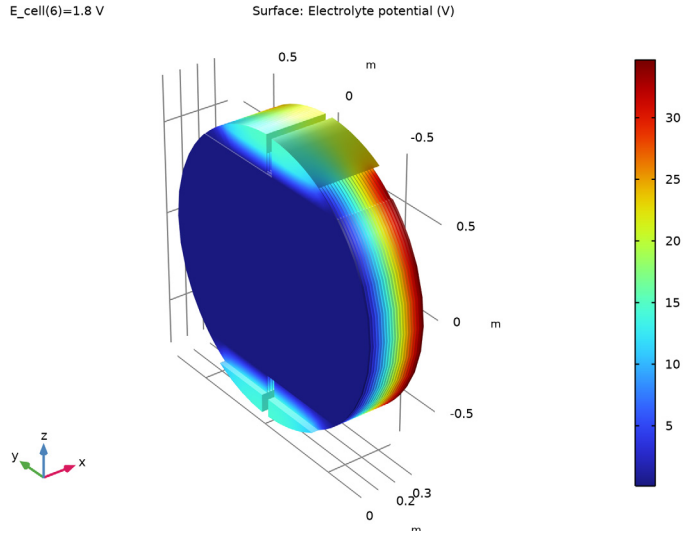

Figure 4: Electrolyte phase potential.

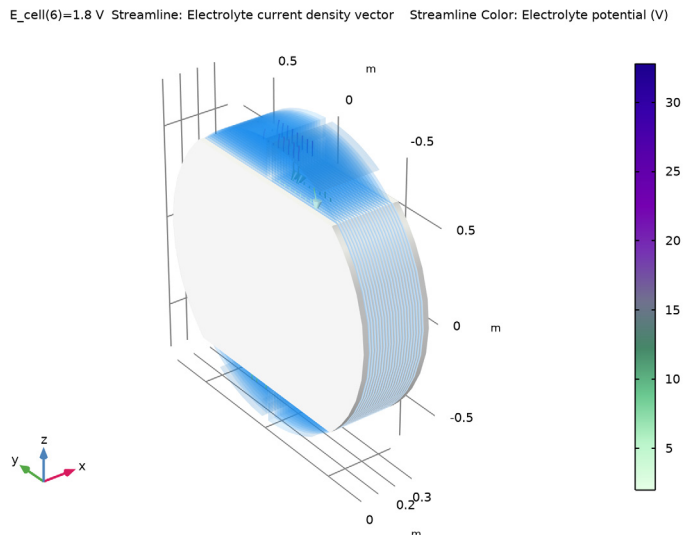

Figure 5: Current streamlines in the inlet and outlet channels and manifolds.

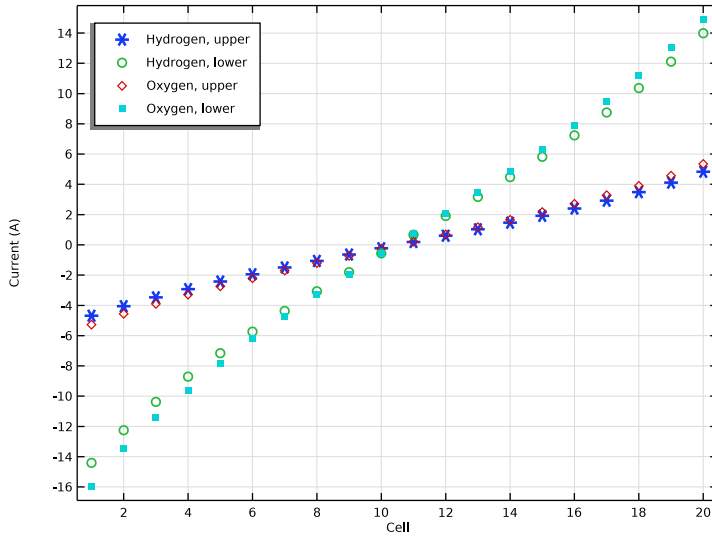

Figure 6: Entering or exiting shunt current per cell at an average cell voltage of 1.3 V.

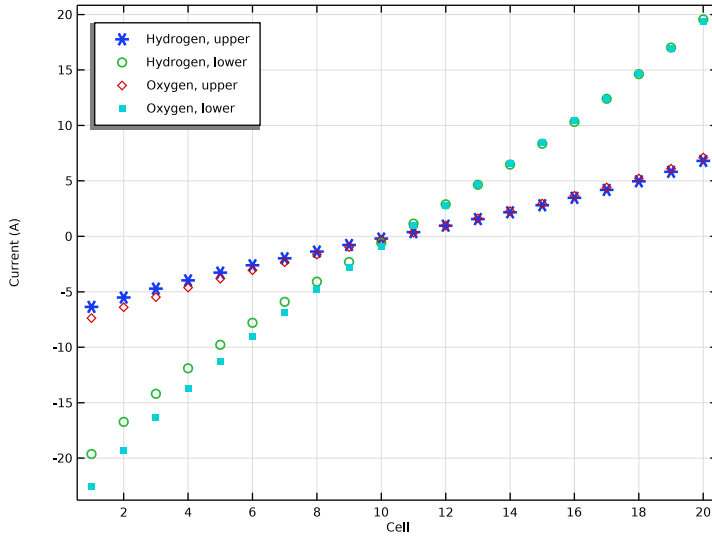

Figure 7: Entering or exiting shunt current per cell at an average cell voltage of 1.8 V.

The shunt current streamlines in Figure 5 can be integrated over the internal boundary between each manifold and the corresponding electrolyte compartment to compute the individual entry/exit shunt currents of each cell. This is shown in Figure 6 and Figure 7 for the average cell voltages of 1.3 and 1.8 V. The lower effective electrolyte conductivity in the upper channels, due to lower electrolyte volume fraction (Equation 1) results in lower shunt currents for the outlet channels compared to the inlet channels. It is also seen that the shunt currents are more pronounced toward the end of the stack. The higher stack voltage results in generally higher shunt currents in Figure 7, compared to Figure 6.

Figure 8 shows a polarization plot for the stack, where the total current on the x-axis was computed by integrating the current density over one of the end plates of the stack. The plot also show the open circuit and thermoneutral cell voltage for the operating conditions. The thermoneutral cell voltage is of particular interest since additional heat would be required to heat the stack when operating the electrolyzer below this voltage.

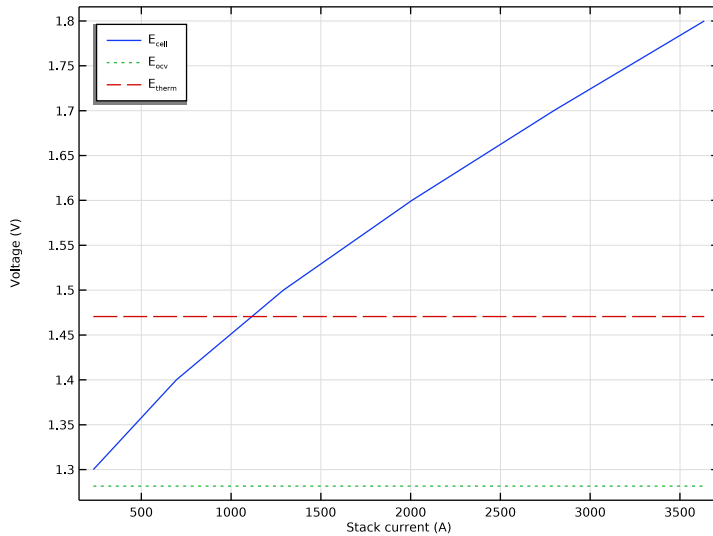

Figure 8: Polarization plot for the stack.

We can also compute the coulombic efficiency for hydrogen production in the stack. This efficiency measure is defined as the total hydrogen evolution current density in all cells, divided by the stack current times the number of cells. The coulombic efficiency is plotted in Figure 9. The interplay between different polarization effects results in the efficiency being lower at lower stack currents.

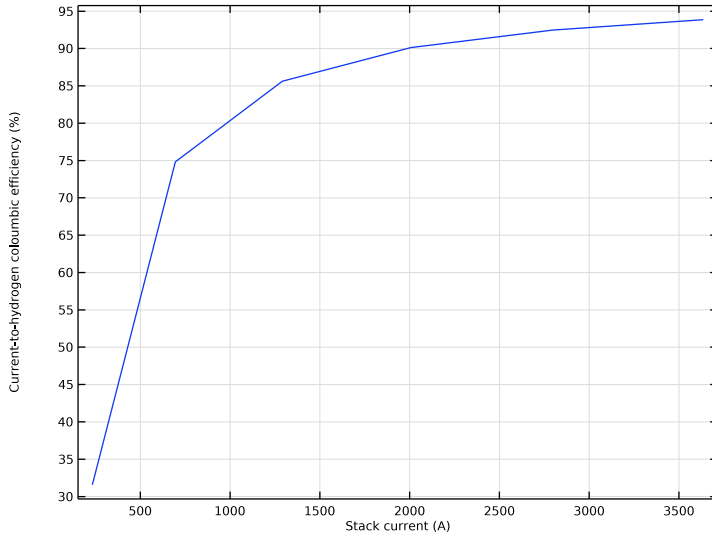

Figure 9: Current-to-hydrogen coulombic efficiency.

Finally, we can also have a look at the energy efficiency of the stack for different current levels in [Figure 10](#). For a system of this kind there are various ways of defining the energy efficiency. Here we base the efficiency measure on the Gibbs free energy of the produced hydrogen, and define the efficiency as the maximum possible energy (per time unit) which would be possible to produce in a fuel cell operating at the same conditions ($I_{112} \times E_{eq}$), divided by the electrical energy required to produce it in the stack ($I_{stack} \times E_{stack}$). The energy efficiency first increases, as a result of the increasing coulombic efficiency ([Figure 9](#)), to reach at maximum around 1400 A. The decrease seen after 1400 A is due to an increasing stack voltage at higher currents ([Figure 8](#)).

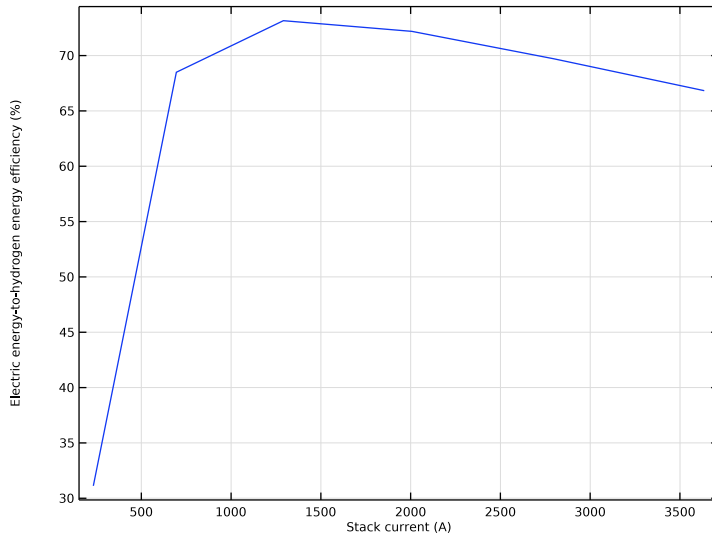

Figure 10: Electrical energy-to-hydrogen energy (Gibbs) efficiency.

Notes About the COMSOL Implementation

A **Global Evaluation Sweep** is used to compute the table values plotted in Figure 6 and Figure 7. To update these plots and the corresponding table after recomputing the model, the global evaluation sweep needs to be reevaluated.

Application Library path: Fuel_Cell_and_Electrolyzer_Module/Electrolyzers/aec_shunt_currents

Modeling Instructions



From the **File** menu, choose **New**.

NEW

In the **New** window, click  **Model Wizard**.

MODEL WIZARD

I In the **Model Wizard** window, click  **3D**.

- 2 In the **Select Physics** tree, select **Electrochemistry > Water Electrolyzers > Alkaline (we)**.
- 3 Click **Add**.
- 4 Click  **Study**.
- 5 In the **Select Study** tree, select **Preset Studies for Selected Physics Interfaces > Stationary with Initialization**.
- 6 Click  **Done**.

GEOMETRY I

Load the geometry sequence from a file.

- 1 In the **Geometry** toolbar, click **Insert Sequence** and choose **Insert Sequence**.
- 2 Browse to the model's Application Libraries folder and double-click the file `aec_shunt_currents_geom_sequence.mph`.
- 3 In the **Geometry** toolbar, click  **Build All**.
- 4 In the **Model Builder** window, under **Component I (comp1)** click **Geometry I**.

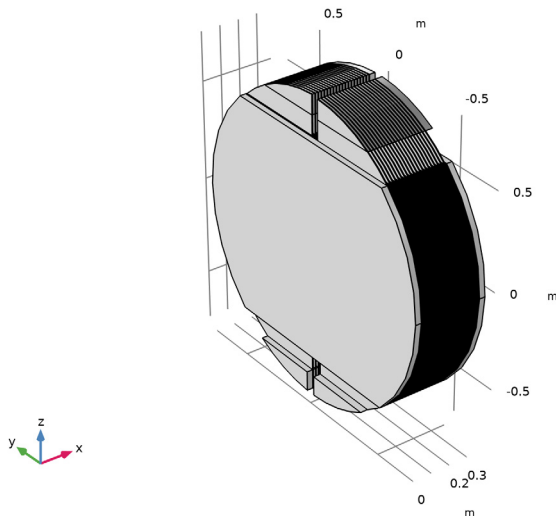

- 5 In the **Model Builder** window, collapse the **Geometry I** node.

DEFINITIONS

The stack geometry has a high aspect ratio, with the cell thicknesses being very small in relation to the cross-sectional area. To facilitate setting up the physics, add a view with scaling in the x direction as follows:

View 20



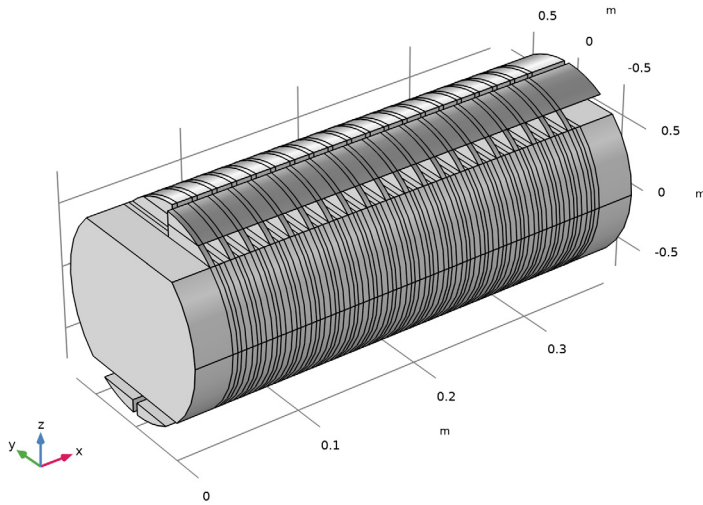

- 1 In the **Model Builder** window, expand the **Component 1 (comp1) > Definitions** node.
- 2 Right-click **Definitions** and choose **View**.

Camera

- 1 In the **Model Builder** window, expand the **View 20** node, then click **Camera**.
- 2 In the **Settings** window for **Camera**, locate the **Camera** section.
- 3 From the **View scale** list, choose **Manual**.
- 4 In the **x scale** text field, type 10.
- 5 Click  **Update**.



You can now toggle between the two views at any time.

- 6 Click the  **Go to Default View** button in the **Graphics** toolbar.
- 7 In the **Graphics** window toolbar, click  next to  **Go to Default View**, then choose **Go to View 1**.
- 8 In the **Graphics** window toolbar, click  next to  **Go to Default View**, then choose **Go to View 20**.

GLOBAL DEFINITIONS



Geometry Parameters

Some parameters were loaded with the geometry sequence.



- 1 In the **Model Builder** window, under **Global Definitions** click **Parameters I**.
- 2 In the **Settings** window for **Parameters**, type Geometry Parameters in the **Label** text field.

Physics Parameters

Add some more parameters from a text file.

- 1 In the **Home** toolbar, click  **Parameters** and choose **Add > Parameters**.
- 2 In the **Settings** window for **Parameters**, type Physics Parameters in the **Label** text field.
- 3 Locate the **Parameters** section. Click  **Load from File**.
- 4 Browse to the model's Application Libraries folder and double-click the file `aec_shunt_currents_physics_parameters.txt`.

ADD MATERIAL

- 1 In the **Materials** toolbar, click  **Add Material** to open the **Add Material** window.
This model uses the **Materials** node to define the properties of the bipolar plates, end plates, and electrolyte.
- 2 Go to the **Add Material** window.
- 3 In the tree, select **Built-in > Steel AISI 4340**.
- 4 Right-click and choose **Add to Component I (comp1)**.
- 5 In the tree, select **Fuel Cell and Electrolyzer > Aqueous Alkali > Potassium Hydroxide, KOH**.
- 6 Right-click and choose **Add to Component I (comp1)**.
- 7 In the **Materials** toolbar, click  **Add Material** to close the **Add Material** window.

MATERIALS

Steel AISI 4340 (mat1)

- 1 In the **Settings** window for **Material**, locate the **Geometric Entity Selection** section.
- 2 From the **Selection** list, choose **Current Conductors**.

Potassium Hydroxide, KOH (mat2)

- 1 In the **Model Builder** window, click **Potassium Hydroxide, KOH (mat2)**.
- 2 In the **Settings** window for **Material**, locate the **Geometric Entity Selection** section.
- 3 From the **Selection** list, choose **Electrolyte Compartments**.

DEFINITIONS

Variables 1

- 1 In the **Model Builder** window, under **Component 1 (comp1)** right-click **Definitions** and choose **Variables**.

Add some variable expressions from a text file. Most of these will be used during postprocessing of the solution.

- 2 In the **Settings** window for **Variables**, locate the **Variables** section.

- 3 Click  **Load from File**.

- 4 Browse to the model's Application Libraries folder and double-click the file `aec_shunt_currents_variables.txt`.

Note that some expressions are marked in orange, indicating unknown operators. Add these operators as follows:

Integration 1 (intop1)

- 1 In the **Definitions** toolbar, click  **Nonlocal Couplings** and choose **Integration**.
- 2 In the **Settings** window for **Integration**, type `intop_point_h2` in the **Operator name** text field.
- 3 Locate the **Source Selection** section. From the **Geometric entity level** list, choose **Point**.
- 4 Select Point 15 only.

Integration 2 (intop2)

- 1 In the **Definitions** toolbar, click  **Nonlocal Couplings** and choose **Integration**.
- 2 In the **Settings** window for **Integration**, type `intop_point_o2` in the **Operator name** text field.
- 3 Locate the **Source Selection** section. From the **Geometric entity level** list, choose **Point**.
- 4 Select Point 57 only.

Integration 3 (intop3)

- 1 In the **Definitions** toolbar, click  **Nonlocal Couplings** and choose **Integration**.
- 2 In the **Settings** window for **Integration**, type `intop_h2_electrodes` in the **Operator name** text field.
- 3 Locate the **Source Selection** section. From the **Geometric entity level** list, choose **Boundary**.
- 4 From the **Selection** list, choose **H2 Electrodes**.

Integration 4 (intop4)

- 1 In the **Definitions** toolbar, click  **Nonlocal Couplings** and choose **Integration**.
- 2 In the **Settings** window for **Integration**, type intop_cc in the **Operator name** text field.
- 3 Locate the **Source Selection** section. From the **Geometric entity level** list, choose **Boundary**.
- 4 Select Boundary 1 only.

Integration 5 (intop5)

- 1 In the **Definitions** toolbar, click  **Nonlocal Couplings** and choose **Integration**.
- 2 In the **Settings** window for **Integration**, type intop_upper in the **Operator name** text field.
- 3 Locate the **Source Selection** section. From the **Geometric entity level** list, choose **Boundary**.
- 4 From the **Selection** list, choose **Upper Manifold - Active Cell Boundaries**.

Integration 6 (intop6)

- 1 In the **Definitions** toolbar, click  **Nonlocal Couplings** and choose **Integration**.
- 2 In the **Settings** window for **Integration**, type intop_lower in the **Operator name** text field.
- 3 Locate the **Source Selection** section. From the **Geometric entity level** list, choose **Boundary**.
- 4 From the **Selection** list, choose **Lower Manifold - Active Cell Boundaries**.

Variables 1

All variable expressions should now have turned black.

WATER ELECTROLYZER (WE)

You are now ready to start defining the physics.

- 1 In the **Model Builder** window, under **Component 1 (comp1)** click **Water Electrolyzer (we)**.
- 2 In the **Settings** window for **Water Electrolyzer**, locate the **H2 Gas Mixture** section.
- 3 Clear the **H2O** checkbox.
- 4 Locate the **O2 Gas Mixture** section. Clear the **H2O** checkbox.

Separator 1

- 1 In the **Physics** toolbar, click  **Domains** and choose **Separator**.
- 2 In the **Settings** window for **Separator**, locate the **Domain Selection** section.
- 3 From the **Selection** list, choose **Separators**.

- 4 Locate the **Effective Electrolyte Charge Transport** section. In the ϵ_1 text field, type `eps1_sep`.

Current Collector 1

- 1 In the **Physics** toolbar, click  **Domains** and choose **Current Collector**.
- 2 In the **Settings** window for **Current Collector**, locate the **Domain Selection** section.
- 3 From the **Selection** list, choose **Current Conductors**.
- 4 Locate the **Electrode Charge Transport** section. From the σ_s list, choose **From material**.

H2 Gas-Electrolyte Compartment 1

- 1 In the **Physics** toolbar, click  **Domains** and choose **H2 Gas-Electrolyte Compartment**.
- 2 In the **Settings** window for **H2 Gas-Electrolyte Compartment**, locate the **Domain Selection** section.
- 3 From the **Selection** list, choose **H2 Gas Electrolyte Compartments**.
- 4 Locate the **Effective Electrolyte Charge Transport** section. In the ϵ_1 text field, type `eps1`.

O2 Gas-Electrolyte Compartment 1

- 1 In the **Physics** toolbar, click  **Domains** and choose **O2 Gas-Electrolyte Compartment**.
- 2 In the **Settings** window for **O2 Gas-Electrolyte Compartment**, locate the **Domain Selection** section.
- 3 From the **Selection** list, choose **Oxygen Gas Electrolyte Compartments**.
- 4 Locate the **Effective Electrolyte Charge Transport** section. In the ϵ_1 text field, type `eps1`.

Internal H2 Electrode Surface 1

- 1 In the **Physics** toolbar, click  **Boundaries** and choose **Internal H2 Electrode Surface**.
- 2 In the **Settings** window for **Internal H2 Electrode Surface**, locate the **Boundary Selection** section.
- 3 From the **Selection** list, choose **H2 Electrodes**.

H2 Electrode Reaction 1

- 1 In the **Model Builder** window, click **H2 Electrode Reaction 1**.
- 2 In the **Settings** window for **H2 Electrode Reaction**, locate the **Stoichiometric Coefficients** section.
- 3 In the $\nu_{\text{H}_2\text{O(l)}}$ text field, type `-1`.
- 4 Locate the **Electrode Kinetics** section. From the **Exchange current density type** list, choose **Lumped multistep**.
- 5 In the $i_{0,\text{ref}}(T)$ text field, type `i0_ref_h2`.

6 From the **Pressure dependence** list, choose **Cathodic reaction orders**.

7 In the ξ_{c,H_2} text field, type 1.

Internal O2 Electrode Surface 1

1 In the **Physics** toolbar, click  **Boundaries** and choose **Internal O2 Electrode Surface**.

2 In the **Settings** window for **Internal O2 Electrode Surface**, locate the **Boundary Selection** section.

3 From the **Selection** list, choose **O2 Electrodes**.

O2 Electrode Reaction 1

1 In the **Model Builder** window, click **O2 Electrode Reaction 1**.

2 In the **Settings** window for **O2 Electrode Reaction**, locate the **Stoichiometric Coefficients** section.

3 In the $v_{H_2O(l)}$ text field, type -1.

4 Locate the **Electrode Kinetics** section. From the **Exchange current density type** list, choose **Lumped multistep**.

5 In the $i_{0,ref}(T)$ text field, type $i_{0_ref_o2}$.

6 From the **Pressure dependence** list, choose **Anodic reaction orders**.

7 In the ξ_{a,O_2} text field, type 1.

Electronic Conducting Phase 1

In the **Model Builder** window, under **Component 1 (comp1) > Water Electrolyzer (we)** click **Electronic Conducting Phase 1**.

Electric Ground 1

1 In the **Physics** toolbar, click  **Attributes** and choose **Electric Ground**.

2 Select Boundary 1 only.

Electronic Conducting Phase 1

In the **Model Builder** window, click **Electronic Conducting Phase 1**.

Electric Potential 1

1 In the **Physics** toolbar, click  **Attributes** and choose **Electric Potential**.

2 Select Boundary 1610 only.

3 In the **Settings** window for **Electric Potential**, locate the **Electric Potential** section.

4 In the $\phi_{s,bnd}$ text field, type E_stack .

Electrolyte Phase I

The electrolyte properties need input from the physics with regards to the electrolyte concentration and the temperature.

- 1 In the **Model Builder** window, under **Component 1 (comp1) > Water Electrolyzer (we)** click **Electrolyte Phase I**.
- 2 In the **Settings** window for **Electrolyte Phase**, locate the **Model Input** section.
- 3 From the *c* list, choose **User defined**. In the associated text field, type `c_KOH`.

The model input variables can be defined locally on this node or as a **Common model input**.

GLOBAL DEFINITIONS

Default Model Inputs

- 1 In the **Model Builder** window, under **Global Definitions** click **Default Model Inputs**.
- 2 In the **Settings** window for **Default Model Inputs**, locate the **Browse Model Inputs** section.
- 3 In the tree, select **General > Temperature (K) - minput.T**.
- 4 Find the **Expression for remaining selection** subsection. In the **Temperature** text field, type `T`.

Also, the pressure needs to be set since the equilibrium potentials of the electrode reactions depend on the pressure.

- 5 In the tree, select **General > Pressure (Pa) - minput.pA**.
- 6 In the **Pressure** text field, type `p_abs`.

MESH I

This model requires a manual mesh. The geometry has been set up in such a way that it can easily be swept in the *x* direction. For good accuracy when computing the shunt currents, a more well-resolved mesh is needed in the manifolds and channels.

Size I

- 1 In the **Model Builder** window, under **Component 1 (comp1)** right-click **Mesh I** and choose **Size**.
- 2 In the **Settings** window for **Size**, locate the **Geometric Entity Selection** section.
- 3 From the **Geometric entity level** list, choose **Boundary**.
- 4 From the **Selection** list, choose **Upper/Lower Manifold and Active Area Boundaries (for Meshing)**.
- 5 Locate the **Element Size** section. From the **Predefined** list, choose **Extra fine**.

Size 2

- 1 In the **Model Builder** window, right-click **Mesh 1** and choose **Size**.
- 2 In the **Settings** window for **Size**, locate the **Geometric Entity Selection** section.
- 3 From the **Geometric entity level** list, choose **Domain**.
- 4 From the **Selection** list, choose **Channels**.
- 5 Locate the **Element Size** section. From the **Predefined** list, choose **Finer**.

Swept 1

In the **Mesh** toolbar, click  **Swept**.

Distribution 1

- 1 Right-click **Swept 1** and choose **Distribution**.
- 2 In the **Settings** window for **Distribution**, locate the **Domain Selection** section.
- 3 From the **Selection** list, choose **H2 Gas Electrolyte Compartments**.

Distribution 2

- 1 In the **Model Builder** window, right-click **Swept 1** and choose **Distribution**.
- 2 In the **Settings** window for **Distribution**, locate the **Domain Selection** section.
- 3 From the **Selection** list, choose **Current Conductors**.
- 4 Locate the **Distribution** section. In the **Number of elements** text field, type 1.

Distribution 3

- 1 Right-click **Swept 1** and choose **Distribution**.
- 2 In the **Settings** window for **Distribution**, locate the **Domain Selection** section.
- 3 From the **Selection** list, choose **Oxygen Gas Electrolyte Compartments**.

Distribution 4

- 1 Right-click **Swept 1** and choose **Distribution**.
- 2 In the **Settings** window for **Distribution**, locate the **Domain Selection** section.
- 3 From the **Selection** list, choose **Separators**.
- 4 Locate the **Distribution** section. In the **Number of elements** text field, type 2.

Swept 1

Right-click **Swept 1** and choose **Build Selected**.

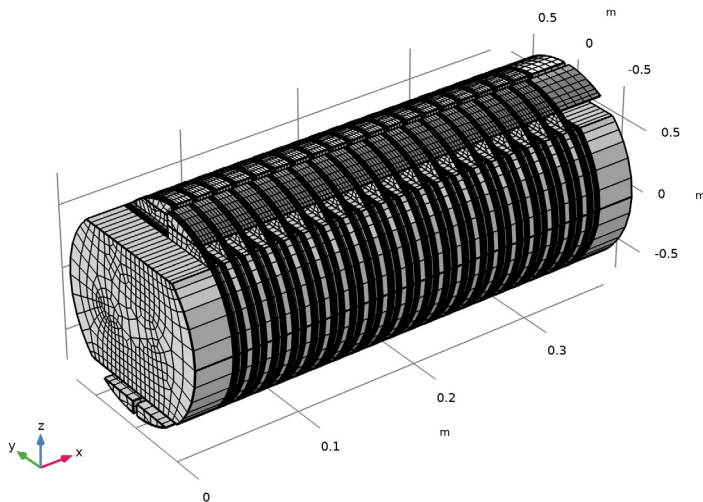

Boundary Layers 1

The local current densities on the electrode surfaces are higher in the regions close to the manifolds. Add boundary layer meshes there in order to improve the shunt current accuracy further.

- 1 In the **Mesh** toolbar, click  **Boundary Layers**.
- 2 In the **Settings** window for **Boundary Layers**, locate the **Geometric Entity Selection** section.
- 3 From the **Geometric entity level** list, choose **Domain**.
- 4 From the **Selection** list, choose **Active Cell Volume**.
- 5 Click to expand the **Transition** section. Clear the **Smooth transition to interior mesh** checkbox.

Boundary Layer Properties

- 1 In the **Model Builder** window, click **Boundary Layer Properties**.
- 2 In the **Settings** window for **Boundary Layer Properties**, locate the **Boundary Selection** section.
- 3 From the **Selection** list, choose **Upper/Lower Active Area Boundaries (for Meshing)**.
- 4 Locate the **Layers** section. In the **Number of layers** text field, type 5.

5 From the **Thickness specification** list, choose **First layer**.

6 In the **Thickness** text field, type $D_{o2}/3$.

Boundary Layers 2

1 In the **Mesh** toolbar, click  **Boundary Layers**.

2 In the **Settings** window for **Boundary Layers**, locate the **Geometric Entity Selection** section.

3 From the **Geometric entity level** list, choose **Domain**.

4 From the **Selection** list, choose **Manifolds**.

5 Locate the **Transition** section. Clear the **Smooth transition to interior mesh** checkbox.

Boundary Layer Properties

1 In the **Model Builder** window, click **Boundary Layer Properties**.

2 In the **Settings** window for **Boundary Layer Properties**, locate the **Boundary Selection** section.

3 From the **Selection** list, choose **Manifold - Active Cell Boundaries**.

4 Locate the **Layers** section. In the **Number of layers** text field, type 2.

5 From the **Thickness specification** list, choose **First layer**.

6 In the **Thickness** text field, type $D_{o2}/3$.

7 Click  **Build All**.

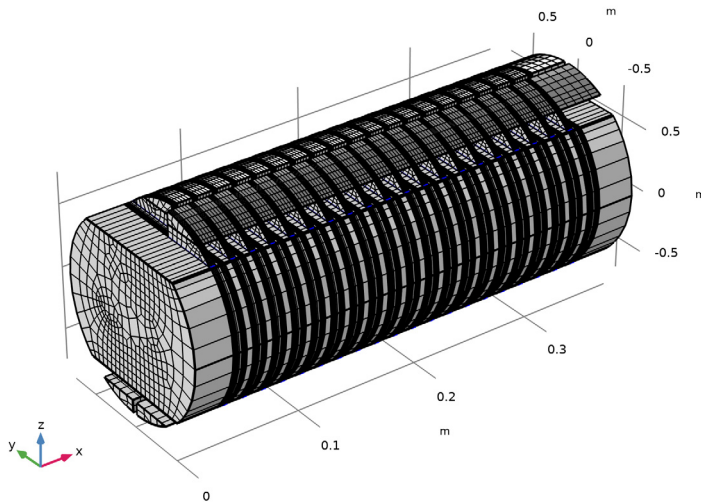

STUDY 1

The model is now ready for solving. Use an auxiliary sweep for sweeping the average cell voltage from 1.3 to 1.8 V.

Step 2: Stationary

- 1 In the **Model Builder** window, under **Study 1** click **Step 2: Stationary**.
- 2 In the **Settings** window for **Stationary**, click to expand the **Study Extensions** section.
- 3 Select the **Auxiliary sweep** checkbox.
- 4 Click  **Add**.
- 5 In the table, enter the following settings:

Parameter name	Parameter value list	Parameter unit
E_cell (Cell voltage (varied in sweep))	range (1.3, 0.1, 1.8)	V

- 6 In the **Study** toolbar, click  **Compute**.

RESULTS

Electrode Potential with Respect to Ground

Reproduce the plots from the [Results and Discussion](#) section as follows.



- 1 In the **Settings** window for **3D Plot Group**, type Electrode Potential with Respect to Ground in the **Label** text field.
- 2 In the **Model Builder** window, expand the **Electrode Potential with Respect to Ground** node.

Arrow Volume 1, Multislice 1

- 1 In the **Model Builder** window, under **Results > Electrode Potential with Respect to Ground**, Ctrl-click to select **Multislice 1** and **Arrow Volume 1**.
- 2 Right-click and choose **Disable**.

Surface 1

- 1 In the **Model Builder** window, right-click **Electrode Potential with Respect to Ground** and choose **Surface**.
- 2 In the **Settings** window for **Surface**, locate the **Expression** section.
- 3 In the **Expression** text field, type `w_e.phis`.
- 4 In the **Electrode Potential with Respect to Ground** toolbar, click  **Plot**.

- 5 In the **Graphics** window toolbar, click  next to  **Go to Default View**, then choose **Go to View 1**.

Electrode Potential with Respect to Ground

- 1 In the **Model Builder** window, click **Electrode Potential with Respect to Ground**.
- 2 In the **Settings** window for **3D Plot Group**, locate the **Plot Settings** section.
- 3 Clear the **Plot dataset edges** checkbox.
- 4 In the **Electrode Potential with Respect to Ground** toolbar, click  **Plot**.

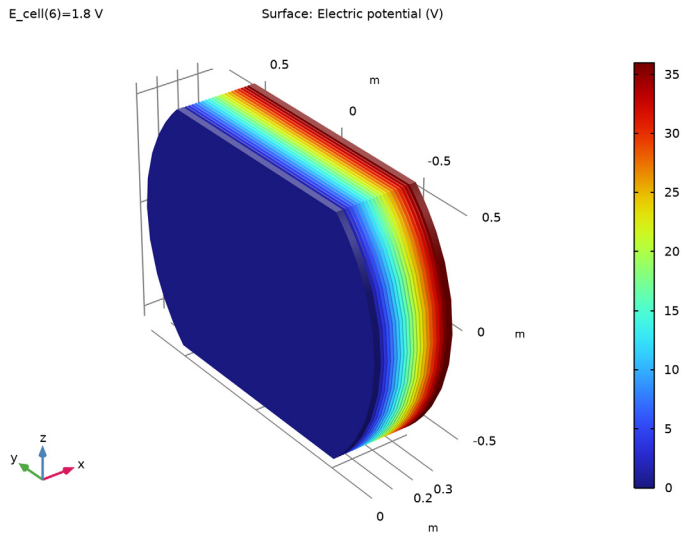

Electrolyte Potential

- 1 In the **Model Builder** window, under **Results** click **Electrolyte Potential (we)**.
- 2 In the **Settings** window for **3D Plot Group**, type Electrolyte Potential in the **Label** text field.
- 3 Locate the **Plot Settings** section. Clear the **Plot dataset edges** checkbox.
- 4 In the **Model Builder** window, expand the **Electrolyte Potential** node.

Arrow Volume 1, Multislice 1

- 1 In the **Model Builder** window, under **Results** > **Electrolyte Potential**, Ctrl-click to select **Multislice 1** and **Arrow Volume 1**.
- 2 Right-click and choose **Disable**.

Surface 1

- 1 In the **Model Builder** window, right-click **Electrolyte Potential** and choose **Surface**.
- 2 In the **Electrolyte Potential** toolbar, click  **Plot**.
- 3 In the **Model Builder** window, click **Surface 1**.

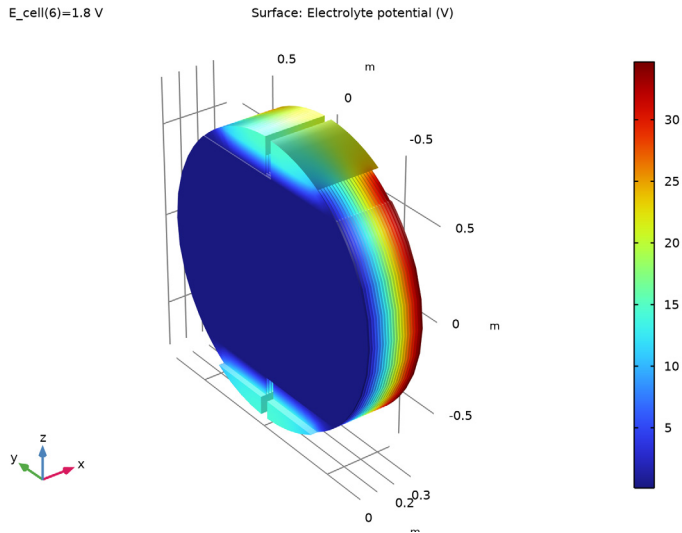

Shunt Current Streamlines

- 1 In the **Results** toolbar, click  **3D Plot Group**.
- 2 In the **Settings** window for **3D Plot Group**, type Shunt Current Streamlines in the **Label** text field.
- 3 Locate the **Plot Settings** section. Clear the **Plot dataset edges** checkbox.

Streamline 1

- 1 Right-click **Shunt Current Streamlines** and choose **Streamline**.
- 2 In the **Settings** window for **Streamline**, locate the **Streamline Positioning** section.
- 3 In the **Number** text field, type 100.
- 4 Locate the **Selection** section. From the **Selection** list, choose **Manifold - Active Cell Boundaries**.
- 5 Locate the **Coloring and Style** section. Find the **Point style** subsection. From the **Type** list, choose **Arrow**.

Selection 1

- 1 Right-click **Streamline 1** and choose **Selection**.

- 2 In the **Settings** window for **Selection**, locate the **Selection** section.
- 3 From the **Selection** list, choose **Channels and Manifolds**.

Color Expression 1

- 1 In the **Model Builder** window, right-click **Streamline 1** and choose **Color Expression**.
- 2 In the **Settings** window for **Color Expression**, click to expand the **Title** section.
- 3 From the **Title type** list, choose **Automatic**.
- 4 Locate the **Coloring and Style** section. From the **Color table** list, choose **AuroraBorealis**.

Surface 1

- 1 In the **Model Builder** window, right-click **Shunt Current Streamlines** and choose **Surface**.
- 2 In the **Settings** window for **Surface**, locate the **Expression** section.
- 3 In the **Expression** text field, type 1.
- 4 Click to expand the **Title** section. From the **Title type** list, choose **None**.

Material Appearance 1

Right-click **Surface 1** and choose **Material Appearance**.

Surface 2

- 1 In the **Model Builder** window, right-click **Shunt Current Streamlines** and choose **Surface**.
- 2 In the **Settings** window for **Surface**, locate the **Expression** section.
- 3 In the **Expression** text field, type 1.
- 4 Locate the **Title** section. From the **Title type** list, choose **None**.

Material Appearance 1

- 1 Right-click **Surface 2** and choose **Material Appearance**.
- 2 In the **Settings** window for **Material Appearance**, locate the **Appearance** section.
- 3 From the **Material** list, choose **Potassium Hydroxide, KOH (mat2)**.

Transparency 1

- 1 In the **Model Builder** window, right-click **Surface 2** and choose **Transparency**.
- 2 In the **Settings** window for **Transparency**, locate the **Transparency** section.
- 3 Set the **Transparency** value to **0.9**.

4 In the **Shunt Current Streamlines** toolbar, click  **Plot**.

E_cell(6)=1.8 V Streamline: Electrolyte current density vector Streamline Color: Electrolyte potential (V)

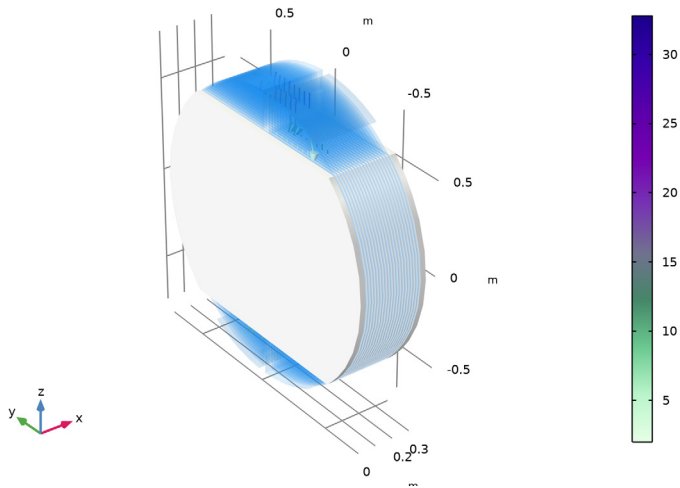

Polarization Plot

- 1 In the **Results** toolbar, click  **ID Plot Group**.
- 2 In the **Settings** window for **ID Plot Group**, type Polarization Plot in the **Label** text field.

Global I

- 1 Right-click **Polarization Plot** and choose **Global**.
- 2 In the **Settings** window for **Global**, click **Replace Expression** in the upper-right corner of the **y-Axis Data** section. From the menu, choose **Global definitions** > **Parameters** > **E_cell - Cell voltage (varied in sweep) - V**.
- 3 Click **Add Expression** in the upper-right corner of the **y-Axis Data** section. From the menu, choose **Component I (comp I)** > **Definitions** > **Variables** > **Eeq_cell - Cell equilibrium voltage - V**.
- 4 Click **Add Expression** in the upper-right corner of the **y-Axis Data** section. From the menu, choose **Component I (comp I)** > **Definitions** > **Variables** > **Etherm_cell - Cell thermoneutral voltage - V**.
- 5 Locate the **x-Axis Data** section. From the **Parameter** list, choose **Expression**.
- 6 Click **Replace Expression** in the upper-right corner of the **x-Axis Data** section. From the menu, choose **Component I (comp I)** > **Definitions** > **Variables** > **I_stack - Stack current - A**.

- 7 Click to expand the **Coloring and Style** section. Find the **Line style** subsection. From the **Line** list, choose **Cycle**.
- 8 Click to expand the **Legends** section. From the **Legends** list, choose **Manual**.
- 9 In the table, enter the following settings:

Legends
E_{cell}
E_{ocv}
E_{therm}

Polarization Plot

- 1 In the **Model Builder** window, click **Polarization Plot**.
- 2 In the **Settings** window for **ID Plot Group**, locate the **Legend** section.
- 3 From the **Position** list, choose **Upper left**.
- 4 Locate the **Plot Settings** section.
- 5 Select the **y-axis label** checkbox. In the associated text field, type **Voltage (V)**.
- 6 Click to expand the **Title** section. From the **Title type** list, choose **None**.
- 7 In the **Polarization Plot** toolbar, click  **Plot**.

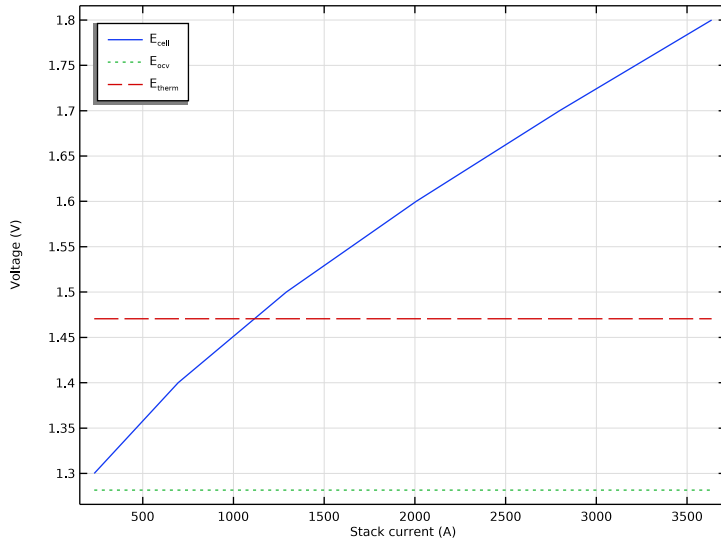

Coulombic Efficiency

- 1 In the **Results** toolbar, click  **ID Plot Group**.

- 2 In the **Settings** window for **ID Plot Group**, type Coulombic Efficiency in the **Label** text field.

Global I

- 1 Right-click **Coulombic Efficiency** and choose **Global**.
- 2 In the **Settings** window for **Global**, click **Replace Expression** in the upper-right corner of the **y-Axis Data** section. From the menu, choose **Component I (comp I) > Definitions > Variables > Eff_coulombic - Current-to-hydrogen coulombic efficiency - I**.
- 3 Locate the **y-Axis Data** section. In the table, enter the following settings:

Expression	Unit	Description
Eff_coulombic	%	Current-to-hydrogen coulombic efficiency

- 4 Locate the **x-Axis Data** section. From the **Parameter** list, choose **Expression**.
- 5 Click **Replace Expression** in the upper-right corner of the **x-Axis Data** section. From the menu, choose **Component I (comp I) > Definitions > Variables > I_stack - Stack current - A**.
- 6 Locate the **Legends** section. Clear the **Show legends** checkbox.

Coulombic Efficiency

- 1 In the **Model Builder** window, click **Coulombic Efficiency**.
- 2 In the **Settings** window for **ID Plot Group**, locate the **Title** section.
- 3 From the **Title type** list, choose **None**.

4 In the **Coulombic Efficiency** toolbar, click  **Plot**.

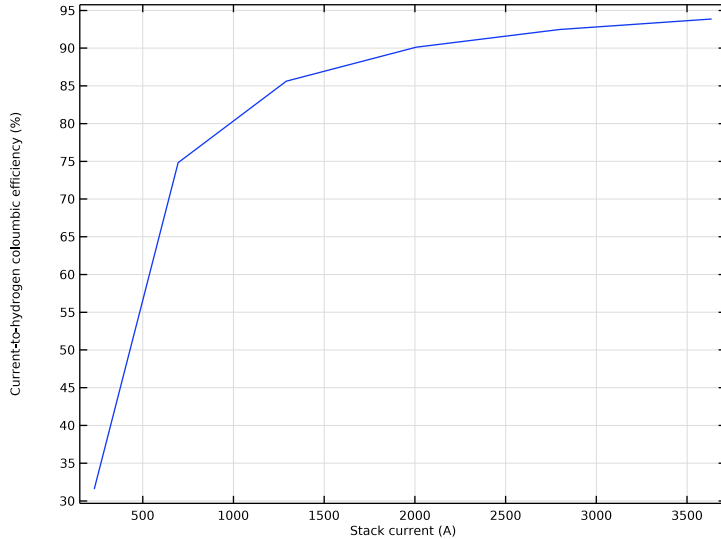

Energy Efficiency

1 In the **Results** toolbar, click  **ID Plot Group**.

2 In the **Settings** window for **ID Plot Group**, type Energy Efficiency in the **Label** text field.

Global I

1 Right-click **Energy Efficiency** and choose **Global**.

2 In the **Settings** window for **Global**, click **Replace Expression** in the upper-right corner of the **y-Axis Data** section. From the menu, choose **Component I (comp I) > Definitions > Variables > Eff_energy - Electric energy-to-hydrogen energy efficiency - I**.

3 Locate the **y-Axis Data** section. In the table, enter the following settings:

Expression	Unit	Description
Eff_energy	%	Electric energy-to-hydrogen energy efficiency

4 Locate the **x-Axis Data** section. From the **Parameter** list, choose **Expression**.

5 Click **Replace Expression** in the upper-right corner of the **x-Axis Data** section. From the menu, choose **Component I (comp I) > Definitions > Variables > I_stack - Stack current - A**.

6 Locate the **Legends** section. Clear the **Show legends** checkbox.

Energy Efficiency

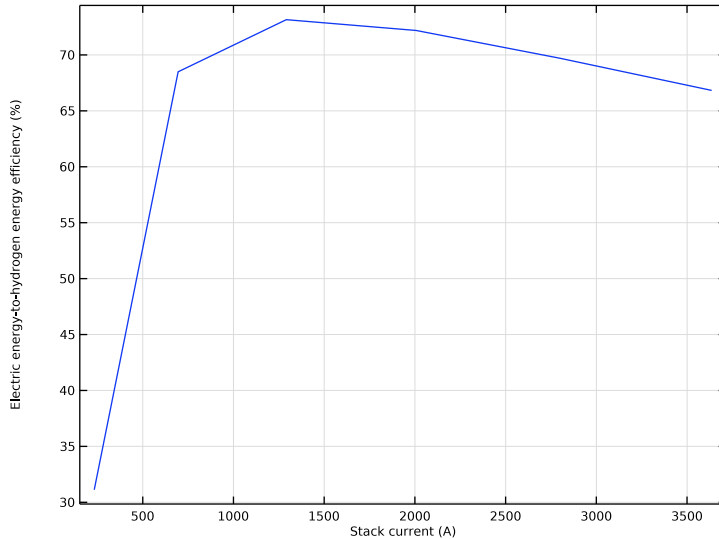

- 1 In the **Model Builder** window, click **Energy Efficiency**.
- 2 In the **Settings** window for **ID Plot Group**, locate the **Title** section.
- 3 From the **Title type** list, choose **None**.
- 4 In the **Energy Efficiency** toolbar, click  **Plot**.



Global Evaluation Sweep 1

- 1 In the **Results** toolbar, click  **More Derived Values** and choose **Other > Global Evaluation Sweep**.
- 2 In the **Settings** window for **Global Evaluation Sweep**, locate the **Data** section.
- 3 From the **Parameter value (E_cell (V))** list, choose **1.3**.
- 4 Locate the **Parameters** section. In the table, enter the following settings:

Parameter name	Parameter value list
Cell	range(1,1,N_cells)

- 5 Locate the **Expressions** section. Click  **Load from File**.
- 6 Browse to the model's Application Libraries folder and double-click the file `aec_shunt_currents_global_sweep_evaluation_expressions.txt`.
- 7 Click  **Evaluate**.

Shunt Currents per Cell



- 1 In the **Results** toolbar, click  **ID Plot Group**.
- 2 In the **Settings** window for **ID Plot Group**, type Shunt Currents in the **Label** text field.
- 3 In the **Label** text field, type Shunt Currents per Cell.

Table Graph 1

- 1 Right-click **Shunt Currents per Cell** and choose **Table Graph**.
- 2 In the **Settings** window for **Table Graph**, click to expand the **Legends** section.
- 3 Select the **Show legends** checkbox.
- 4 In the **Shunt Currents per Cell** toolbar, click  **Plot**.
- 5 Locate the **Coloring and Style** section. Find the **Line style** subsection. From the **Line** list, choose **None**.
- 6 Find the **Line markers** subsection. From the **Marker** list, choose **Cycle**.

Shunt Currents per Cell

- 1 In the **Model Builder** window, click **Shunt Currents per Cell**.
- 2 In the **Settings** window for **ID Plot Group**, locate the **Plot Settings** section.
- 3 Select the **y-axis label** checkbox. In the associated text field, type Current (A).
- 4 Locate the **Legend** section. From the **Position** list, choose **Upper left**.
- 5 In the **Shunt Currents per Cell** toolbar, click  **Plot**.

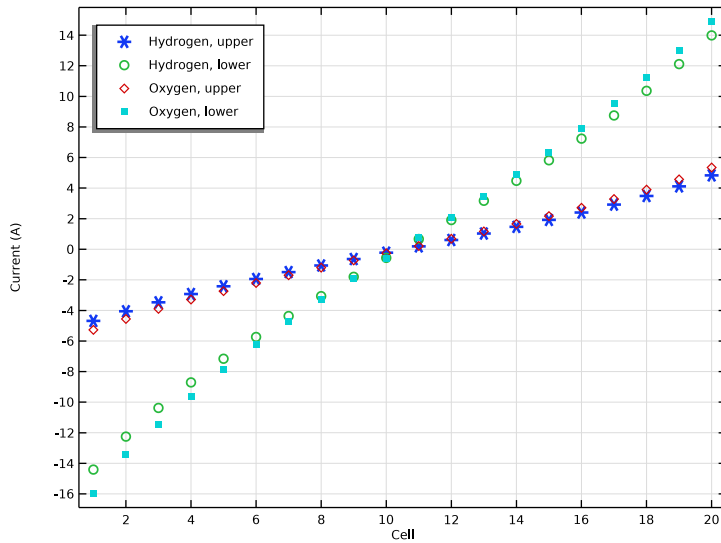

Global Evaluation Sweep 1

- 1 In the **Model Builder** window, under **Results > Derived Values** click **Global Evaluation Sweep 1**.
- 2 In the **Settings** window for **Global Evaluation Sweep**, locate the **Data** section.
- 3 From the **Parameter value (E_cell (V))** list, choose **1.8**.
- 4 Click **Evaluate**.

Table Graph 1

- 1 In the **Model Builder** window, under **Results > Shunt Currents per Cell** click **Table Graph 1**.
- 2 In the **Shunt Currents per Cell** toolbar, click **Plot**.

