



Electrodeposition of an Inductor Coil

Introduction

This example models the deposition of an inductor coil on the $\mu\text{-m}$ -scale, where diffusion limitations govern the deposition rate. A $10\ \mu\text{m}$ thick photoresist mask has been used to create the deposition pattern. As the deposition process proceeds, the depth of the pattern created by the mask decreases, which in turn affects the current distribution over the active surface.

Model Definition

The model geometry is shown in [Figure 1](#). The geometry consists of two domains: the $10\ \mu\text{m}$ extrusion of the deposition pattern down into the photoresist film, and a diffusion layer in form of a rectangular block, $50\ \mu\text{m}$ thick, on top of the photoresist.

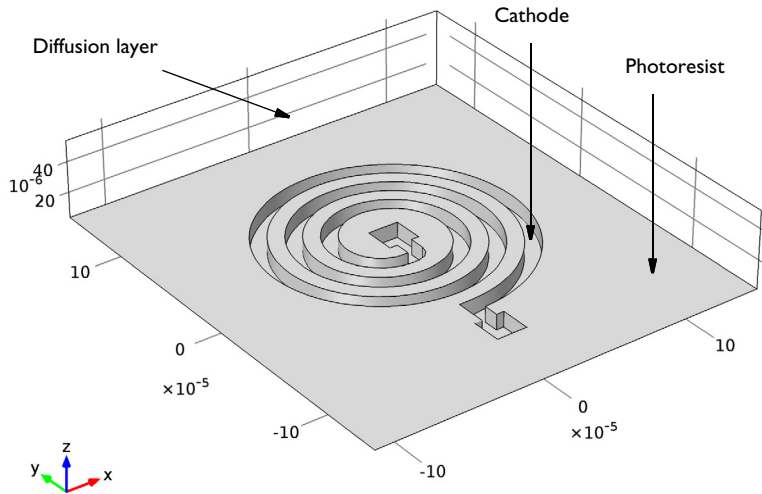
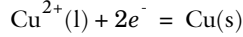

Figure 1: Model geometry. The extruded spiral pattern forms the vertical photoresist walls, $10\ \mu\text{m}$ high. The diffusion layer, in form of a rectangular block, is $50\ \mu\text{m}$ thick.

CURRENT CONDUCTION, ELECTROCHEMICAL REACTIONS, AND GEOMETRY DEFORMATION

The potential gradients in the electrolyte are assumed to be negligible. Hence, the Electrodeposition, Tertiary with the Electroanalysis charge balance model is used, using a constant electrolyte potential of $0\ \text{V}$.

On the bottom boundary, the cathode, the electrode reaction



follows the following kinetics expression for the charge transfer current i_{ct} :

$$i_{\text{ct}} = i_0 \left(\exp\left(\frac{1.5F\eta}{RT}\right) - \frac{c_{\text{Cu}^{2+}}}{c_{\text{Cu}^{2+},\text{ref}}} \exp\left(-\frac{0.5F\eta}{RT}\right) \right)$$

where i_0 is the exchange current density (10 A/m²), η the overpotential, F Faraday's constant (96,485 C/mol), R the molar gas constant (8.1345 J/(mol·K)), T the temperature, $c_{\text{Cu}^{2+}}$ the electrolyte copper ion concentration (mol/m³), and $c_{\text{Cu}^{2+},\text{ref}}$, the reference copper concentration in the bulk electrolyte (500 mol/m³).

Set the current density of the cathode to have an average value of 10 A/dm². All boundaries except the cathode and the top bulk electrolyte boundary are isolated.

The electrode reaction causes the electrode boundary to move in the normal direction with a velocity v_{dep} (m/s) according to

$$v_{\text{dep}} = -\frac{M_{\text{Cu}} i_{\text{ct}}}{\rho_{\text{Cu}} 2F}$$

where M_{Cu} is the molar mass (0.06355 kg/mol) and ρ_{Cu} the density (8960 kg/m³) of copper, respectively.

The extruded pattern domain is allowed to deform according to the electrode boundary deposition rate, whereas the diffusion layer domain is set to be fixed. The vertical walls of the photoresist are fixed in the x and y directions, whereas the interior boundary between the fixed and free moving domain is set to have zero deformation in the z direction.

TRANSPORT OF COPPER IONS IN THE ELECTROLYTE

The transport of copper ions in the electrolyte is described by Fickian diffusion. Model this transport using the Electrodeposition, Tertiary interface, solving for the electrolyte copper ion concentration, $c_{\text{Cu}^{2+}}$. Set the diffusion coefficient to 10^{-9} m²/s.

At the top electrolyte bulk boundary, set the concentration to the bulk concentration, $c_{\text{Cu}^{2+},\text{ref}}$. On the cathode, couple the flux of ions, $N_{\text{Cu}^{2+}}$ (mol/(m²·s)), to the electrochemical reactions via Faraday's law:

$$N_{\text{Cu}^{2+}} = \frac{i_{\text{ct}}}{2F}$$

Assume No flux conditions for all other boundaries.

Solve the problem using a time-dependent study, investigating the deposition during 180 s, with an initial copper concentration in the electrolyte set to $c_{\text{Cu}^{2+},\text{ref}}$.

Results and Discussion

Figure 2 shows the concentration and current streamlines in the electrolyte after 180 s. The copper ion concentration at the cathode is significantly lower than in the bulk. In addition, the concentration at the cathode is slightly higher in outer parts of the pattern compared to the center.

Time=180 s Slice: Molar concentration, c (mol/m³) Surface: Molar concentration, c (mol/m³) Streamline: Total flux (spatial and material frames)

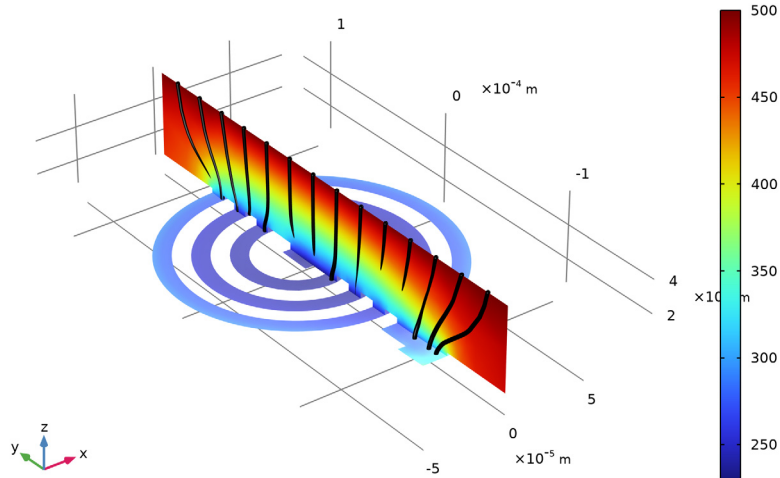

Figure 2: Concentration profile and current streamlines in the electrolyte at $t = 180$ s.

Figure 3 shows the local electrode current, i_{ct} , at the cathode at $t = 180$ s. The deposition currents are higher at the outer parts of the pattern due to the higher copper ion concentration.

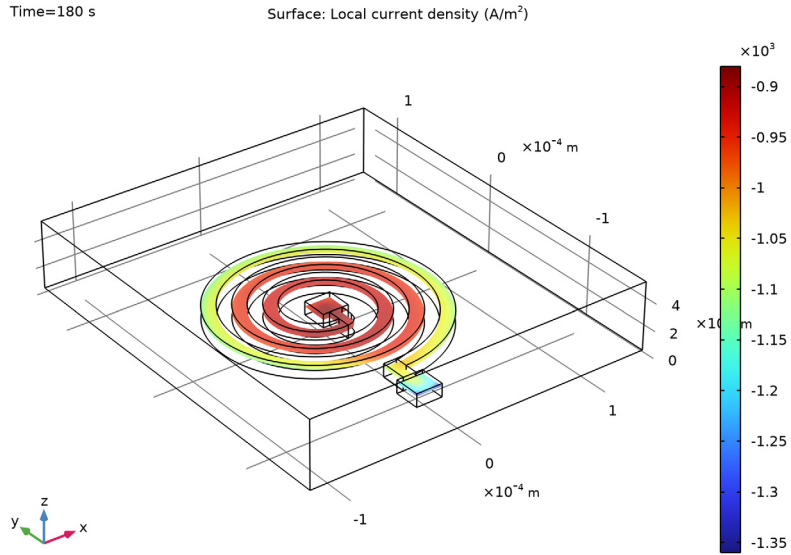

Figure 3: Electrode reaction current density at $t = 180$ s.

Figure 4 shows the deformation and deposited copper thickness after 180 s. The thickness is significantly thicker on the outermost part of the pattern.

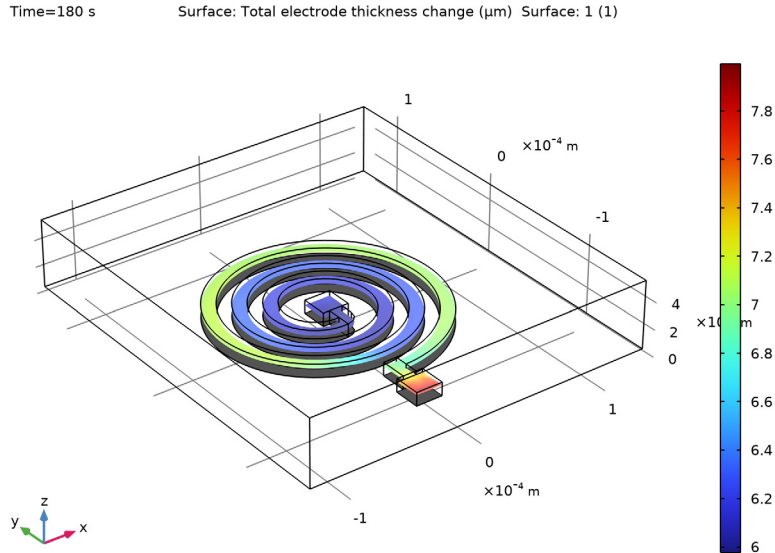

Figure 4: Thickness of the deposited copper layer at 180 s.

Notes About the COMSOL Implementation

By using a Nondeforming Boundary condition on the vertical photoresist walls, and by only allowing deformation to occur along a given line on the cathode, the number of degrees of freedom for the problem gets reduced. This reduces the computation time.

Application Library path: Electrodeposition_Module/
Tutorials_with_Deforming_Geometries/inductor_coil

Modeling Instructions



From the **File** menu, choose **New**.

NEW

In the **New** window, click  **Model Wizard**.

MODEL WIZARD

- 1 In the **Model Wizard** window, click  **3D**.
- 2 In the **Select Physics** tree, select **Electrochemistry > Electrodeposition, Deformed Geometry > Electrodeposition, Tertiary with Supporting Electrolyte**.
- 3 Click **Add**.
- 4 In the **Number of species** text field, type 1.
- 5 In the **Concentrations (mol/m³)** table, enter the following settings:

c
- 6 Click  **Study**.
- 7 In the **Select Study** tree, select **Preset Studies for Selected Physics Interfaces > Time Dependent with Initialization**.
- 8 Click  **Done**.

GLOBAL DEFINITIONS

Load the model parameters from a text file.

Parameters 1

- 1 In the **Model Builder** window, under **Global Definitions** click **Parameters 1**.
- 2 In the **Settings** window for **Parameters**, locate the **Parameters** section.
- 3 Click  **Load from File**.
- 4 Browse to the model's Application Libraries folder and double-click the file `inductor_coil_parameters.txt`.

Analytic 1 (an1)

Define two analytical functions that will be used when drawing the spirals in the geometry.

- 1 In the **Home** toolbar, click  **Functions** and choose **Global > Analytic**.
- 2 In the **Settings** window for **Analytic**, type `spiralX` in the **Function name** text field.
- 3 Locate the **Definition** section. In the **Expression** text field, type `-(s/(2*pi)*a_tot+R)*sin(s)`.
- 4 In the **Arguments** text field, type `s, R`.

5 Locate the **Units** section. In the table, enter the following settings:

Argument	Unit
s	1
R	m

6 In the **Function** text field, type m.

Analytic 2 (an2)

1 In the **Home** toolbar, click  **Functions** and choose **Global > Analytic**.

2 In the **Settings** window for **Analytic**, type spirals in the **Function name** text field.

3 Locate the **Definition** section. In the **Expression** text field, type $-(s/(2*\pi)*a_tot+R)*\cos(s)$.

4 In the **Arguments** text field, type s, R.

5 Locate the **Units** section. In the table, enter the following settings:

Argument	Unit
s	1
R	m

6 In the **Function** text field, type m.

GEOMETRY I

Now draw the geometry. Start with the deposition pattern, using a work plane.

Work Plane 1 (wp1)

1 In the **Geometry** toolbar, click  **Work Plane**.

2 In the **Settings** window for **Work Plane**, click  **Go to Plane Geometry**.

Work Plane 1 (wp1) > Plane Geometry

In the **Model Builder** window, click **Plane Geometry**.

Work Plane 1 (wp1) > Parametric Curve 1 (pc1)

1 In the **Work Plane** toolbar, click  **More Primitives** and choose **Parametric Curve**.

2 In the **Settings** window for **Parametric Curve**, locate the **Parameter** section.



3 In the **Maximum** text field, type w_tot.

4 Locate the **Expressions** section. In the **xw** text field, type spirals(s, r0).



5 In the **yw** text field, type spirals(s, r0).

6 Click  **Build Selected**.



Work Plane 1 (wp1) > Parametric Curve 2 (pc2)

- 1 In the **Work Plane** toolbar, click  **More Primitives** and choose **Parametric Curve**.
- 2 In the **Settings** window for **Parametric Curve**, locate the **Parameter** section.
- 3 In the **Maximum** text field, type w_tot .
- 4 Locate the **Expressions** section. In the **xw** text field, type $spiralX(s, r0+a1)$.
- 5 In the **yw** text field, type $spiralY(s, r0+a1)$.
- 6 Click  **Build Selected**.



Work Plane 1 (wp1) > Rectangle 1 (r1)

- 1 In the **Work Plane** toolbar, click  **Rectangle**.
- 2 In the **Settings** window for **Rectangle**, locate the **Size and Shape** section.
- 3 In the **Width** text field, type $a1$.
- 4 In the **Height** text field, type $2*a1$.
- 5 Locate the **Position** section. In the **yw** text field, type $-r0-a1$.
- 6 Click  **Build Selected**.

Work Plane 1 (wp1) > Square 1 (sq1)

- 1 In the **Work Plane** toolbar, click  **Square**.
- 2 In the **Settings** window for **Square**, locate the **Size** section.
- 3 In the **Side length** text field, type $2*a1$.
- 4 Locate the **Position** section. In the **xw** text field, type $-a1/2$.
- 5 In the **yw** text field, type $-a1$.
- 6 Click  **Build Selected**.

Work Plane 1 (wp1) > Fillet 1 (fil1)

- 1 In the **Work Plane** toolbar, click  **Fillet**.
- 2 Click the  **Zoom Extents** button in the **Graphics** toolbar.

3 On the object **r1**, select Point 2 only.

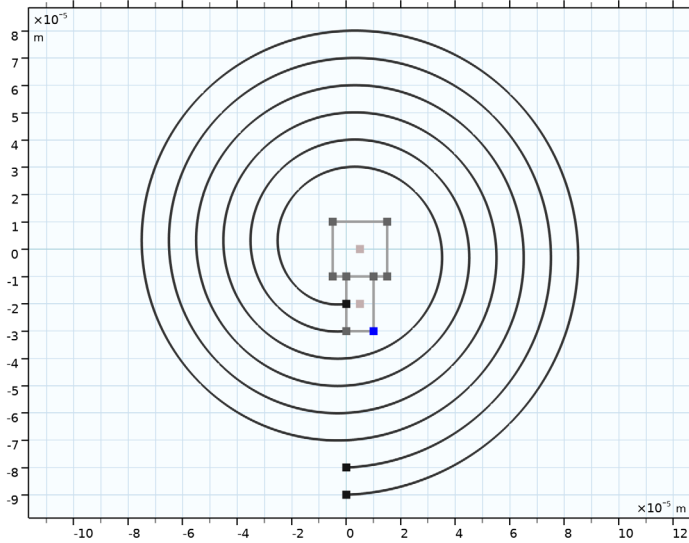

4 In the **Settings** window for **Fillet**, locate the **Radius** section.

5 In the **Radius** text field, type $a1$.

6 Click  **Build Selected**.

Work Plane 1 (wp1) > Rectangle 2 (r2)

1 In the **Work Plane** toolbar, click  **Rectangle**.

2 In the **Settings** window for **Rectangle**, locate the **Size and Shape** section.

3 In the **Width** text field, type $a1$.

4 In the **Height** text field, type $2*a1$.

5 Locate the **Position** section. In the **xw** text field, type $-a1$.

6 In the **yw** text field, type $-r0-2*a1-laps*a_{tot}$.

7 Click  **Build Selected**.

Work Plane 1 (wp1) > Square 2 (sq2)

1 In the **Work Plane** toolbar, click  **Square**.

2 In the **Settings** window for **Square**, locate the **Size** section.

3 In the **Side length** text field, type $2*a1$.

4 Locate the **Position** section. In the **xw** text field, type $-1.5*a1$.

5 In the **yw** text field, type $-r0-4*a1-laps*a_{tot}$.

6 Click  **Build Selected**.

Work Plane 1 (wp1) > Convert to Solid 1 (csol1)

1 In the **Work Plane** toolbar, click  **Conversions** and choose **Convert to Solid**.

2 Click in the **Graphics** window and then press Ctrl+A to select all objects.

3 In the **Settings** window for **Convert to Solid**, click  **Build Selected**.

Extrude 1 (ext1)

1 In the **Model Builder** window, under **Component 1 (comp1) > Geometry 1** right-click **Work Plane 1 (wp1)** and choose **Extrude**.

2 In the **Settings** window for **Extrude**, locate the **Distances** section.

3 In the table, enter the following settings:

Distances (m)
d_pr

4 Click  **Build Selected**.

Block 1 (blk1)

1 In the **Geometry** toolbar, click  **Block**.

2 In the **Settings** window for **Block**, locate the **Size and Shape** section.

3 In the **Width** text field, type $2*(r0+a_tot*1aps+d_d1)$.

4 In the **Depth** text field, type $2*(r0+a_tot*1aps+d_d1)+3*a1$.

5 In the **Height** text field, type d_d1 .

6 Locate the **Position** section. In the **y** text field, type $-2*a1$.

7 In the **z** text field, type $d_pr+d_d1/2$.

8 From the **Base** list, choose **Center**.

9 Click  **Build Selected**.

DEFINITIONS

Add a number of selections to facilitate domain and boundary selection when setting up the physics.

1 Click the  **Transparency** button in the **Graphics** toolbar.



Fixed domain

1 In the **Definitions** toolbar, click  **Explicit**.

2 Select Domain 1 only.

3 In the **Settings** window for **Explicit**, type Fixed domain in the **Label** text field.

Deforming domain

- 1 In the **Definitions** toolbar, click  **Explicit**.
- 2 In the **Settings** window for **Explicit**, locate the **Input Entities** section.
- 3 Under **Selections to invert**, click  **Add**.
- 4 In the **Add** dialog, select **Fixed domain** in the **Selections to invert** list.
- 5 Click **OK**.
- 6 In the **Settings** window for **Explicit**, type Deforming domain in the **Label** text field.



Exterior boundaries

- 1 In the **Definitions** toolbar, click  **Explicit**.
- 2 In the **Settings** window for **Explicit**, locate the **Input Entities** section.
- 3 Select the **All domains** checkbox.
- 4 Locate the **Output Entities** section. From the **Output entities** list, choose **Adjacent boundaries**.
- 5 In the **Label** text field, type Exterior boundaries.

Bulk electrolyte boundary

- 1 In the **Definitions** toolbar, click  **Explicit**.
- 2 In the **Settings** window for **Explicit**, locate the **Input Entities** section.
- 3 From the **Geometric entity level** list, choose **Boundary**.
- 4 Select Boundary 4 only.
- 5 In the **Label** text field, type Bulk electrolyte boundary.

Cathode

- 1 In the **Definitions** toolbar, click  **Explicit**.
- 2 In the **Settings** window for **Explicit**, locate the **Input Entities** section.
- 3 From the **Geometric entity level** list, choose **Boundary**.
- 4 Click  **Paste Selection**.
- 5 In the **Paste Selection** dialog, type 8, 13, 18, 25, 30 in the **Selection** text field.
- 6 Click **OK**.
- 7 In the **Settings** window for **Explicit**, type Cathode in the **Label** text field.

Fixed boundaries

- 1 In the **Definitions** toolbar, click  **Adjacent**.

- 2 In the **Settings** window for **Adjacent**, locate the **Input Entities** section.
- 3 Under **Input selections**, click **+ Add**.
- 4 In the **Add** dialog, select **Fixed domain** in the **Input selections** list.
- 5 Click **OK**.
- 6 In the **Settings** window for **Adjacent**, type **Fixed boundaries** in the **Label** text field.

Photoresist vertical walls

- 1 In the **Definitions** toolbar, click  **Difference**.
- 2 In the **Settings** window for **Difference**, locate the **Geometric Entity Level** section.
- 3 From the **Level** list, choose **Boundary**.
- 4 Locate the **Input Entities** section. Under **Selections to add**, click **+ Add**.
- 5 In the **Add** dialog, select **Exterior boundaries** in the **Selections to add** list.
- 6 Click **OK**.
- 7 In the **Settings** window for **Difference**, locate the **Input Entities** section.
- 8 Under **Selections to subtract**, click **+ Add**.
- 9 In the **Add** dialog, in the **Selections to subtract** list, choose **Cathode** and **Fixed boundaries**.
- 10 Click **OK**.
- 11 In the **Settings** window for **Difference**, type **Photoresist vertical walls** in the **Label** text field.

TERTIARY CURRENT DISTRIBUTION, NERNST-PLANCK (TCD)

Now start setting up the physics. First, set the charge conservation model to **Electroanalysis (no potential gradients)** assuming that the expected potential gradients in the modeled diffusion layer are negligible. Then, set the current distribution model and the transport of copper ions in the electrolyte. The electrolyte is assumed to be quiescent within the modeled diffusion layer.

- 1 In the **Model Builder** window, under **Component 1 (comp1)** click **Tertiary Current Distribution, Nernst-Planck (tcd)**.
- 2 In the **Settings** window for **Tertiary Current Distribution, Nernst-Planck**, locate the **Electrolyte Charge Conservation** section.
- 3 From the **Charge conservation model** list, choose **Electroanalysis (no potential gradients)**.

Electrolyte 1

- 1 In the **Model Builder** window, under **Component 1 (comp1)** > **Tertiary Current Distribution, Nernst-Planck (tcd)** click **Electrolyte 1**.

- 2 In the **Settings** window for **Electrolyte**, locate the **Diffusion** section.
- 3 In the D_c text field, type D_Cu.

Initial Values I

- 1 In the **Model Builder** window, click **Initial Values I**.
- 2 In the **Settings** window for **Initial Values**, locate the **Initial Values** section.
- 3 In the c text field, type c_ref.

Electrode Surface I

- 1 In the **Physics** toolbar, click  **Boundaries** and choose **Electrode Surface**.
- 2 In the **Settings** window for **Electrode Surface**, locate the **Boundary Selection** section.
- 3 From the **Selection** list, choose **Cathode**.
- 4 Click to expand the **Dissolving-Depositing Species** section. Click **+** **Add**.
- 5 Locate the **Electrode Phase Potential Condition** section. From the **Electrode phase potential condition** list, choose **Average current density**.
- 6 In the $i_{l,average}$ text field, type i_avg.

Electrode Reaction I

- 1 In the **Model Builder** window, click **Electrode Reaction I**.
- 2 In the **Settings** window for **Electrode Reaction**, locate the **Stoichiometric Coefficients** section.
- 3 In the n text field, type 2.
- 4 In the ν_c text field, type -1.
- 5 In the **Stoichiometric coefficients for dissolving-depositing species:** table, enter the following settings:

Species	Stoichiometric coefficient (I)
sl	1

- 6 Locate the **Equilibrium Potential** section. In the $E_{eq,ref}(T)$ text field, type Eeq_Cu.
- 7 Locate the **Electrode Kinetics** section. In the $i_{0,ref}(T)$ text field, type i0.
- 8 In the α_a text field, type alpha_a.

Concentration I

- 1 In the **Physics** toolbar, click  **Boundaries** and choose **Concentration**.
- 2 In the **Settings** window for **Concentration**, locate the **Boundary Selection** section.
- 3 From the **Selection** list, choose **Bulk electrolyte boundary**.

- 4 Locate the **Concentration** section. Select the **Species c** checkbox.
- 5 In the $c_{0,c}$ text field, type `c_ref`.
Linear shape functions for concentration and electric potential are sufficient for this model setup. They also result in reduced computation time and memory requirements when compared to the default quadratic shape functions.
- 6 In the **Model Builder** window, click **Tertiary Current Distribution, Nernst-Planck (tcd)**.
- 7 In the **Settings** window for **Tertiary Current Distribution, Nernst-Planck**, click to expand the **Discretization** section.
- 8 From the **Concentration** list, choose **Linear**.
- 9 From the **Electric potential** list, choose **Linear**.

COMPONENT 1 (COMP1)

Prescribed Deformation 1

- 1 In the **Physics** toolbar, click  **Deformed Geometry** and choose **Prescribed Deformation**.
- 2 In the **Settings** window for **Prescribed Deformation**, locate the **Geometric Entity Selection** section.
- 3 From the **Selection** list, choose **Fixed domain**.

MULTIPHYSICS

Nondeforming Boundary 1 (ndbdg1)

Constrain the movement on the vertical walls of the photoresist and on the boundary between the fixed and deforming domain by using the **Zero normal displacement** setting. This imposes a more stable constraint than the default **Zero normal velocity** condition.

- 1 In the **Model Builder** window, under **Component 1 (comp1) > Multiphysics** click **Nondeforming Boundary 1 (ndbdg1)**.
- 2 In the **Settings** window for **Nondeforming Boundary**, locate the **Nondeforming Boundary** section.
- 3 From the **Boundary condition** list, choose **Zero normal displacement**.

Nondeforming Boundary 2 (ndbdg2)

- 1 In the **Physics** toolbar, click  **Multiphysics Couplings** and choose **Boundary > Nondeforming Boundary**.
- 2 In the **Settings** window for **Nondeforming Boundary**, locate the **Boundary Selection** section.
- 3 From the **Selection** list, choose **Photoresist vertical walls**.

- 4 Locate the **Nondeforming Boundary** section. From the **Boundary condition** list, choose **Zero normal displacement**.
- 5 Select the **Allow deformation along specified line only** checkbox.
- 6 Specify the \mathbf{l}_{def} vector as

0	X_g
0	Y_g
1	Z_g

MESH 1

- 1 In the **Model Builder** window, under **Component 1 (comp1)** click **Mesh 1**.
- 2 In the **Settings** window for **Mesh**, locate the **Sequence Type** section.
- 3 From the list, choose **User-controlled mesh**.
- 4 In the **Mesh** toolbar, click  **Clear Sequence**.

Mapped 1

- 1 In the **Mesh** toolbar, click  **More Generators** and choose **Mapped**.
- 2 Select Boundary 25 only.
- 3 In the **Settings** window for **Mapped**, click to expand the **Reduce Element Skewness** section.
- 4 Select the **Adjust edge mesh** checkbox.

Size 1

- 1 Right-click **Mapped 1** and choose **Size**.
- 2 In the **Settings** window for **Size**, locate the **Element Size** section.
- 3 Click the **Custom** button.
- 4 Locate the **Element Size Parameters** section.
- 5 Select the **Maximum element size** checkbox. In the associated text field, type $a1/2$.

6 Click  **Build Selected**.

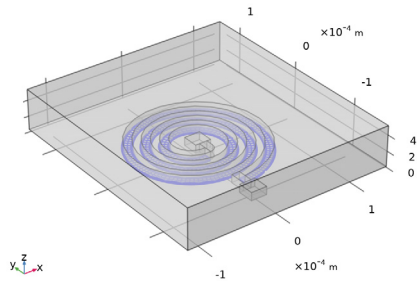

Free Triangular 1

- 1 In the **Mesh** toolbar, click  **More Generators** and choose **Free Triangular**.
- 2 Select Boundaries 8, 13, 18, and 30 only.

Size 1

- 1 Right-click **Free Triangular 1** and choose **Size**.
- 2 In the **Settings** window for **Size**, locate the **Element Size** section.
- 3 Click the **Custom** button.
- 4 Locate the **Element Size Parameters** section.
- 5 Select the **Maximum element size** checkbox. In the associated text field, type $a/2$.
- 6 Click  **Build Selected**.

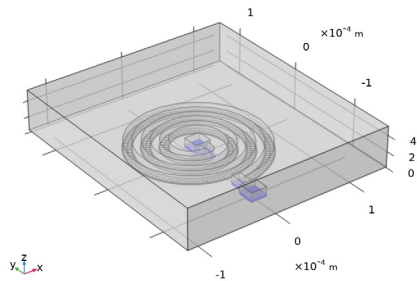

Swept 1

- 1 In the **Mesh** toolbar, click  **Swept**.
- 2 In the **Settings** window for **Swept**, locate the **Domain Selection** section.
- 3 From the **Geometric entity level** list, choose **Domain**.
- 4 From the **Selection** list, choose **Deforming domain**.

Distribution 1

- 1 Right-click **Swept 1** and choose **Distribution**.
- 2 Right-click **Distribution 1** and choose **Build Selected**.

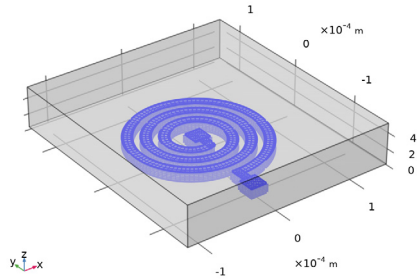

Free Tetrahedral 1

- 1 In the **Mesh** toolbar, click  **Free Tetrahedral**.
- 2 In the **Settings** window for **Free Tetrahedral**, click  **Build Selected**.

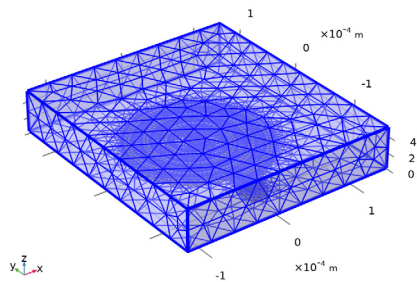

STUDY 1

- 1 In the **Model Builder** window, click **Study 1**.
- 2 In the **Settings** window for **Study**, locate the **Study Settings** section.
- 3 Clear the **Generate default plots** checkbox.

Step 2: Time Dependent

- 1 In the **Model Builder** window, under **Study 1** click **Step 2: Time Dependent**.
- 2 In the **Settings** window for **Time Dependent**, locate the **Study Settings** section.
- 3 In the **Output times** text field, type range (0, 30, 180).
- 4 In the **Study** toolbar, click  **Compute**.

RESULTS

The following steps reproduce the figures from the Results section of the model documentation.

3D Plot Group 1

- 1 In the **Model Builder** window, expand the **Results** node.
- 2 Right-click **Results** and choose **3D Plot Group**.
- 3 Click the  **Transparency** button in the **Graphics** toolbar.
- 4 In the **Settings** window for **3D Plot Group**, locate the **Plot Settings** section.
- 5 Clear the **Plot dataset edges** checkbox.

Slice 1

- 1 Right-click **3D Plot Group 1** and choose **Slice**.
- 2 In the **Settings** window for **Slice**, click **Replace Expression** in the upper-right corner of the **Expression** section. From the menu, choose **Component 1 (comp1) > Tertiary Current Distribution, Nernst-Planck > Species c > c - Molar concentration, c - mol/m³**.
- 3 Locate the **Plane Data** section. In the **Planes** text field, type 1.
- 4 In the **3D Plot Group 1** toolbar, click  **Plot**.

Surface 1



- 1 In the **Model Builder** window, right-click **3D Plot Group 1** and choose **Surface**.
- 2 In the **Settings** window for **Surface**, locate the **Expression** section.
- 3 In the **Expression** text field, type c.
- 4 Click to expand the **Inherit Style** section. From the **Plot** list, choose **Slice 1**.

Selection 1

- 1 Right-click **Surface 1** and choose **Selection**.
- 2 In the **Settings** window for **Selection**, locate the **Selection** section.
- 3 From the **Selection** list, choose **Cathode**.

Streamline 1

- 1 In the **Model Builder** window, right-click **3D Plot Group 1** and choose **Streamline**.
- 2 In the **Settings** window for **Streamline**, click **Replace Expression** in the upper-right corner of the **Expression** section. From the menu, choose **Component 1 (comp1) > Tertiary Current Distribution, Nernst-Planck > Species c > Fluxes > tcd.tflux_cx, ..., tcd.tflux_cz - Total flux (spatial and material frames)**.

- 3 Locate the **Streamline Positioning** section. From the **Positioning** list, choose **Starting-point controlled**.
- 4 From the **Entry method** list, choose **Coordinates**.
- 5 In the **X** text field, type 0.
- 6 In the **Y** text field, type range (-150e-6, 20e-6, 150e-6).
- 7 In the **Z** text field, type d_d1+d_pr.
- 8 Locate the **Coloring and Style** section. Find the **Line style** subsection. From the **Type** list, choose **Tube**.
- 9 Find the **Point style** subsection. From the **Color** list, choose **Black**.
- 10 In the **3D Plot Group 1** toolbar, click  **Plot**.
- 11 Click the  **Zoom Extents** button in the **Graphics** toolbar.



3D Plot Group 2

- 1 In the **Results** toolbar, click  **3D Plot Group**.
- 2 In the **Settings** window for **3D Plot Group**, click to expand the **Selection** section.
- 3 From the **Geometric entity level** list, choose **Boundary**.
- 4 From the **Selection** list, choose **Cathode**.

Change the frame of the dataset edges to Geometry in order to show the outline of the original (undeformed) geometry in the figure.

- 5 Locate the **Plot Settings** section. From the **Frame** list, choose **Geometry (Xg, Yg, Zg)**.

Surface 1

- 1 Right-click **3D Plot Group 2** and choose **Surface**.
- 2 In the **Settings** window for **Surface**, click **Replace Expression** in the upper-right corner of the **Expression** section. From the menu, choose **Component 1 (comp1) > Tertiary Current Distribution, Nernst-Planck > Electrode kinetics > tcd.iloc_er1 - Local current density - A/m²**.
- 3 In the **3D Plot Group 2** toolbar, click  **Plot**.
- 4 Click the  **Zoom Extents** button in the **Graphics** toolbar.

3D Plot Group 3

In the **Model Builder** window, under **Results** right-click **3D Plot Group 2** and choose **Duplicate**.

Surface 1



- 1 In the **Model Builder** window, expand the **3D Plot Group 3** node, then click **Surface 1**.

- 2 In the **Settings** window for **Surface**, click **Replace Expression** in the upper-right corner of the **Expression** section. From the menu, choose **Component 1 (comp1) > Tertiary Current Distribution, Nernst-Planck > Dissolving-depositing species > tcd.sbtot - Total electrode thickness change - m**.
- 3 Locate the **Expression** section. From the **Unit** list, choose **µm**.

Surface 2

- 1 Right-click **Results > 3D Plot Group 3 > Surface 1** and choose **Duplicate**.
- 2 In the **Settings** window for **Surface**, locate the **Data** section.
- 3 From the **Dataset** list, choose **Study 1/Solution 1 (sol1)**.
- 4 From the **Time (s)** list, choose **0**.
- 5 Locate the **Expression** section. In the **Expression** text field, type 1.
- 6 Locate the **Coloring and Style** section. From the **Coloring** list, choose **Uniform**.
- 7 From the **Color** list, choose **Black**.

Selection 1

- 1 In the **3D Plot Group 3** toolbar, click  **Selection**.
- 2 In the **Settings** window for **Selection**, locate the **Selection** section.
- 3 From the **Selection** list, choose **Cathode**.
- 4 In the **3D Plot Group 3** toolbar, click  **Plot**.
- 5 Click the  **Zoom Extents** button in the **Graphics** toolbar.

