



Micromechanics and Macromechanics of a Composite Cylinder

Introduction

Fiber composites are widely used in industrial applications. Compared to more traditional metallic engineering materials, fiber composites often have superior specific stiffness and strength properties, and they are often more corrosion resistant. Also, properties like strength, stiffness, and toughness can often be tailored to specific applications. A fiber composite consists of load carrying fibers embedded in a polymer resin. The composite material is typically a laminate of individual layers, where the fibers in each layer are unidirectional. This model demonstrates how to perform a stress analysis of a laminated composite cylinder.

Modeling individual fibers in every layer in the laminate is unfeasible. A simplified micromechanics model of a single carbon fiber in epoxy is instead used to estimate the homogenized elastic properties of a single layer. These properties are then used in the macromechanical model of the laminated composite cylinder. Two approaches are used to model the laminate, namely the Layerwise (LW) theory and the Equivalent Single Layer (ESL) theory.

Model Definition

This model performs different types of analyses of a laminated composite cylinder. The model is divided into three parts:

- Micromechanics analysis
- Stress analysis using the Layerwise theory
- Stress analysis using the Equivalent Single Layer theory

Eigenfrequencies and mode shapes are computed and compared using both theories.

MICROMECHANICS ANALYSIS

A micromechanics analysis of a single layer is performed in order to obtain its homogenized material properties. The composite layer is assumed to be made of carbon fibers unidirectionally embedded in epoxy resin. A repeating unit cell (RUC) having a cylindrical fiber surrounded by resin is shown in [Figure 1](#). The fiber radius is computed assuming a fiber volume fraction of 0.6.

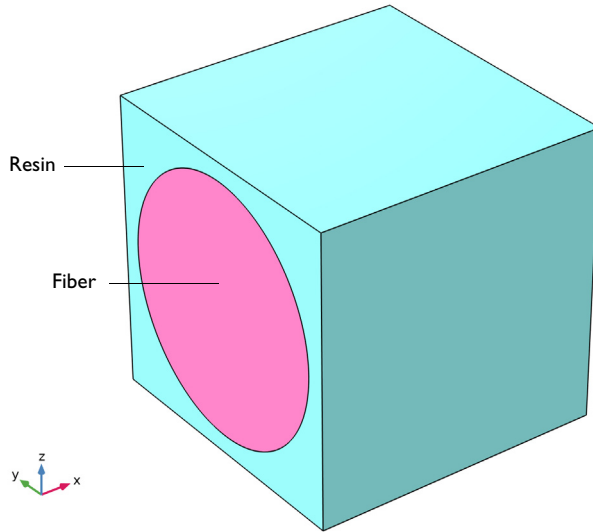

Figure 1: Geometry of the unit cell with a carbon fiber in an epoxy resin.

Fiber and Resin Properties

The layers of the laminate are made of T300 carbon fiber and epoxy polymer. The carbon fiber is assumed to be transversely isotropic, and the epoxy resin is assumed to be isotropic. Both materials are built-in materials in the **Composites** material library. The material properties of fiber and matrix are given in [Table 1](#) and [Table 2](#), respectively.

TABLE 1: CARBON FIBER MATERIAL PROPERTIES.

Material Property	Value
$\{E_1, E_2\}$	$\{230, 15\}$ GPa
G_{12}	27 GPa
$\{\nu_{12}, \nu_{23}\}$	$\{0.2, 0.0714\}$
ρ	1760 kg/m^3

TABLE 2: EPOXY RESIN MATERIAL PROPERTIES.

Material Property	Value
E	3.25 GPa
ν	0.265
ρ	1250 kg/m^3

Cell Periodicity

In order to perform a micromechanics analysis, the **Cell Periodicity** node in the **Solid Mechanics** interface is used. The **Cell Periodicity** node is used to apply periodic boundary conditions to the three pairs of faces of the unit cell.

In order to extract the homogenized elasticity matrix for a layer, the unit cell needs to be analyzed for six different load cases. The **Average Strain** periodicity type needs to be selected to obtain the homogenized elasticity matrix. This is automatically done with the help of the action buttons in the **Cell Periodicity** node. The **Cell Periodicity** node has three action buttons in the tool bar of section called **Periodicity Type: Create Load Groups and Study, Create Material by Reference, and Create Material by Value**. The action button **Create Load Groups and Study** generates six different load groups and a stationary study with six load cases. The action button **Create Material by Reference** generates a **Global Material** with an elasticity matrix corresponding to that of the homogenized material in terms of variables. The action button **Create Material by Value** generates a **Global Material** with an elasticity matrix corresponding to that of the homogenized material in terms of numbers after the study computed. The generated global material can be used to define the properties of individual layers in a composite laminate.

STRESS ANALYSIS USING THE LAYERWISE THEORY

Layerwise (LW) Theory

In the layerwise theory, the degrees of freedom are the displacements (u, v, w) available on the reference surface (or modeled surface) as well as in the through-thickness direction. From a constitutive equation point of view, this theory is similar to 3D solid elasticity. The layerwise theory is useful for detailed modeling of thick composite laminates because it can capture interlaminar shear stresses. It could therefore be used to also study delamination.

Geometry and Boundary Conditions

The model geometry of a composite cylinder with a length of 0.5 m and a radius of 0.1 m is shown in [Figure 2](#). Boundary conditions and loading are:

- One end of the cylinder is fixed.
- The other end has a roller support.
- A load of 1 kN is applied to a quarter of the cylinder outer surface.

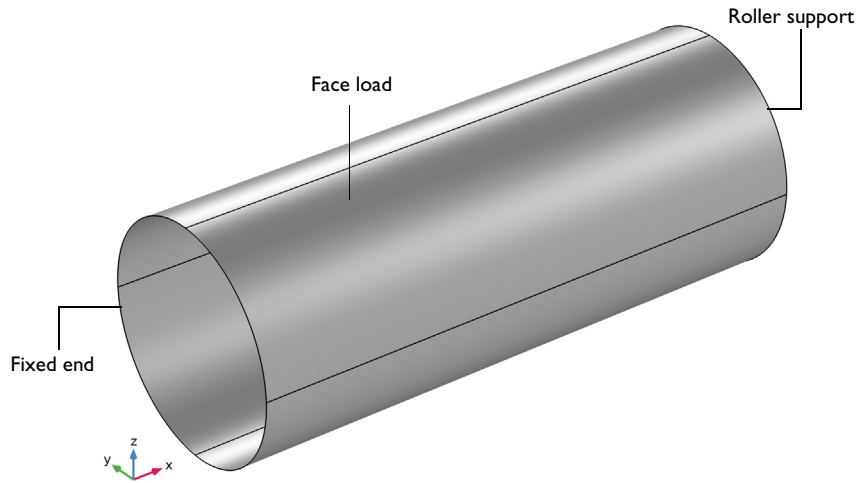

Figure 2: Geometry of the cylinder showing boundary conditions and loading.

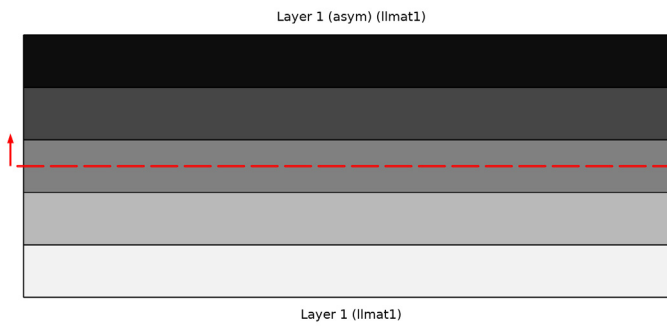

Figure 3: Through-thickness view of the laminated material with five layers.

Stacking Sequence and Material Properties

The laminate consists of five layers of 1 mm thickness, as shown in Figure 3. The orientations of the layers are different. The orientations, starting from the bottom of the laminate, are taken as 0, 45, 90, -45, and 0 degrees, as shown in Figure 4. The orientation of a layer is specified with respect to the laminate coordinate system as shown in Figure 5. The material properties for each layer are given by the homogenized material computed in the micromechanics analysis.

The first principal material direction showing the fiber orientation in each layer of the physical geometry are shown in Figure 6.

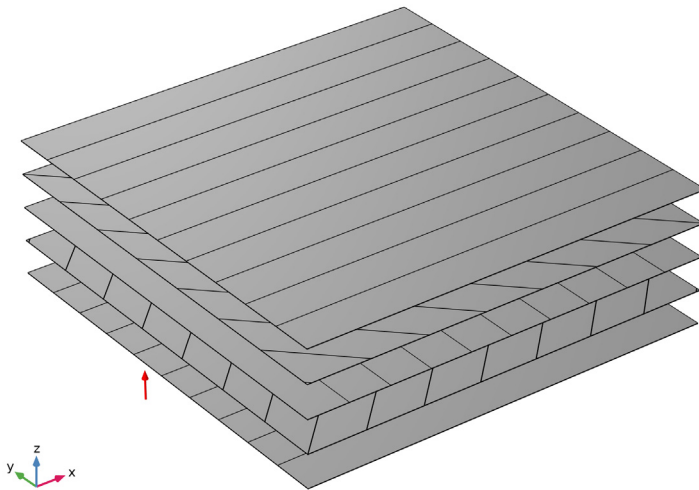

Figure 4: Stacking sequence [0/45/90/-45/0] for the laminate showing the fiber orientation of each layer, from bottom to top.

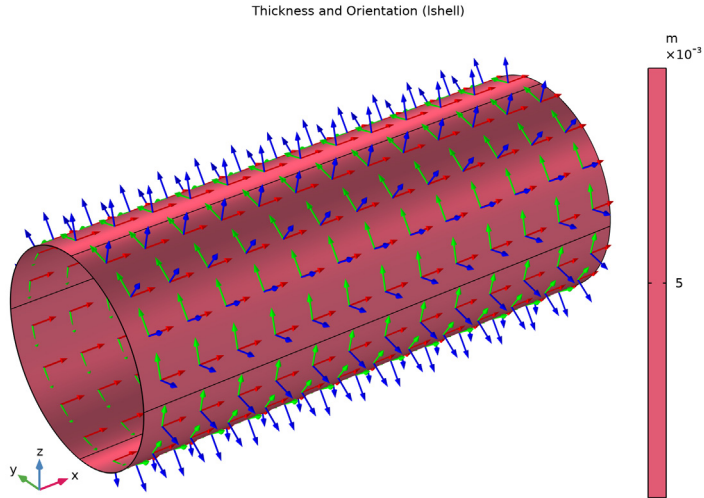

Figure 5: The laminate coordinate system showing the first principal direction along the cylinder axis.

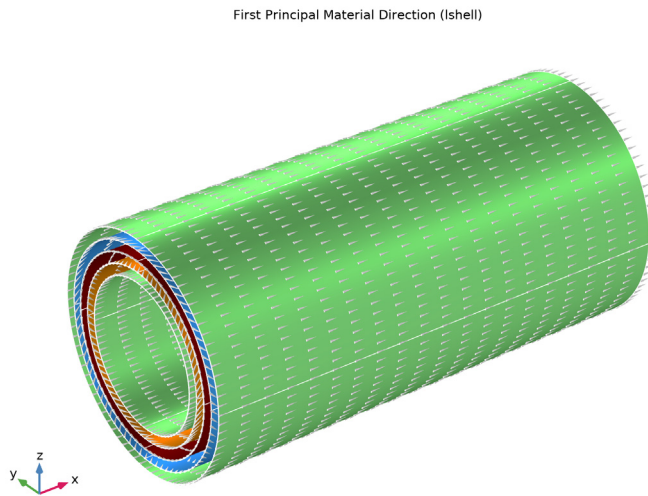

Figure 6: First principal material direction showing the fiber orientation in each layer of the physical geometry. The ply angle is used as a color for each layer.

STRESS ANALYSIS USING THE ESL THEORY

Equivalent Single Layer (ESL) Theory

In the equivalent single layer (ESL) theory, the degrees of freedom are the displacements and rotations on the midplane of the laminate. From a constitutive equation point of view, this theory is similar to 3D shell elasticity. Through-thickness homogenized material properties of the laminate are used. It is therefore computationally less expensive than the layerwise theory. It can be used for the modeling of thin to moderately thick laminates with good accuracy. An aim of this analysis is to compare the results to the results obtained from the layerwise theory.

The model setup, including geometry, boundary conditions, material properties, and so on, is the same as described in the previous section.

Results and Discussion

In the micromechanics analysis, six load cases are used to evaluate the elasticity matrix. The distribution of effective (von Mises) stress for four of the load cases is shown in [Figure 7](#).

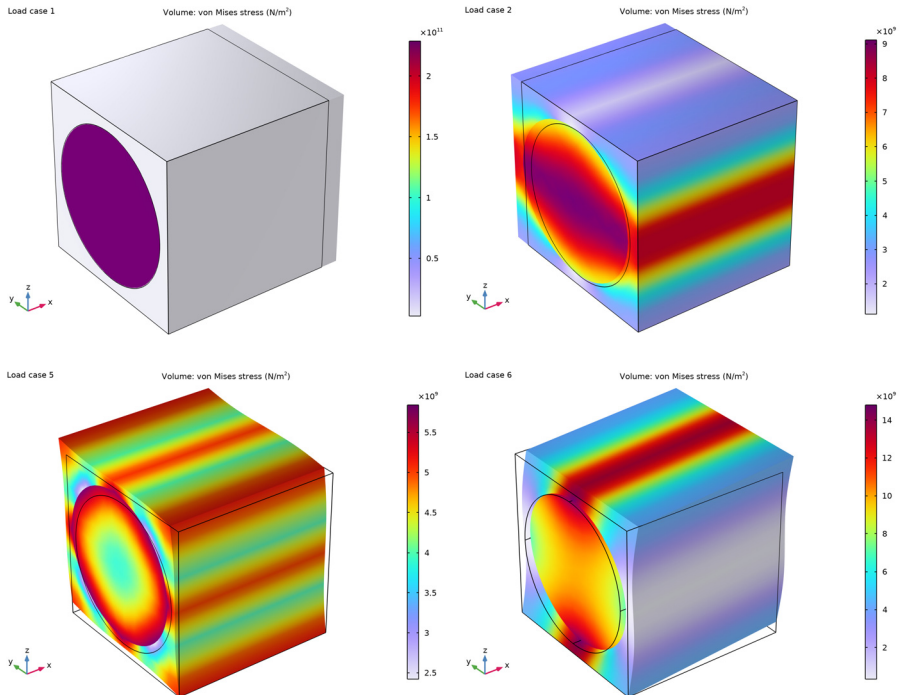

Figure 7: Von Mises stress distribution in the unit cell for four load cases.

The von Mises stress distribution in the composite cylinder obtained from the two theories is presented in [Figure 8](#). Both theories give similar results.

The through-thickness variation of the axial second Piola–Kirchhoff stress at a particular point on the cylinder is shown in [Figure 9](#). We see that the stress variation is discontinuous between layers, but that the two theories predict similar distributions.

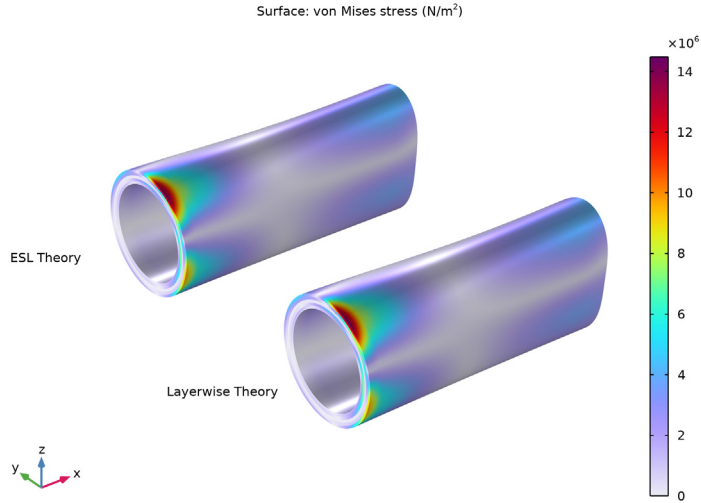

Figure 8: Von Mises stress distribution in the composite cylinder obtained using the Layerwise and ESL theories.

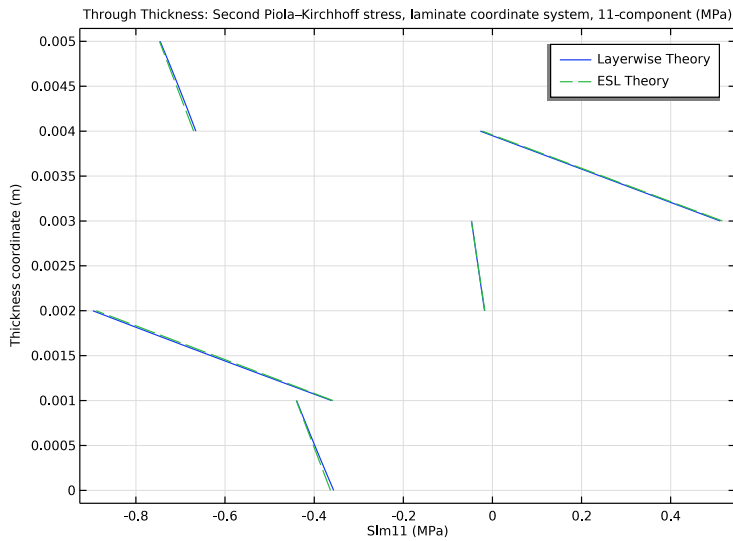

Figure 9: Through-thickness stress variation in the axial direction at a particular point on the cylinder.

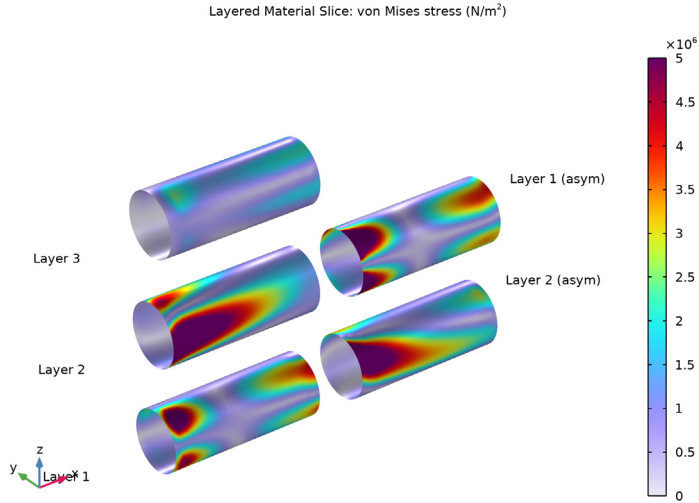

Figure 10: Von Mises stress distribution in the five layers of the laminate.

Figure 10 shows the distribution of von Mises stress in each layer of the laminate using the layerwise theory. The distributions of stress in the individual layers are remarkably different. The middle layer, with fibers perpendicular to the first principal laminate direction, shows the lowest stresses.

The first six eigenfrequencies of the constrained cylinder are shown in Table 3, and the corresponding mode shapes are shown in Figure 11. The eigenfrequencies obtained using the LW and ESL theories match within 0.3%.

TABLE 3: COMPARISON OF EIGENFREQUENCIES.

Eigenfrequencies from layerwise theory (Hz)	Eigenfrequencies from ESL theory (Hz)
475.28	474.70
539.46	538.82
932.47	931.72
970.56	970.41
1182.8	1180.7
1214.4	1212.7

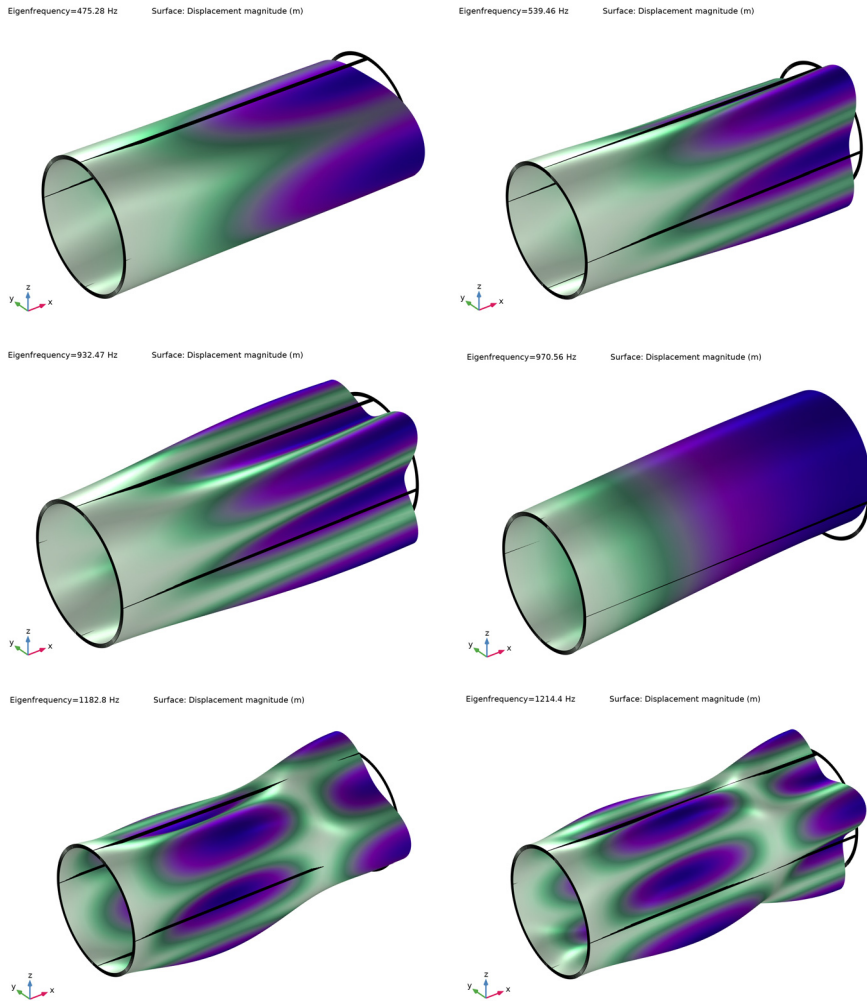

Figure 11: The first six mode shapes and corresponding eigenfrequencies of the cylinder.

Notes About the COMSOL Implementation

- The micromechanics analysis of a single fiber in a resin can be performed using the **Cell Periodicity** node available in the **Solid Mechanics** interface. Using this functionality, the

elasticity matrix of the homogenized material can be computed for the given fiber and resin properties, and the fiber volume fraction.

- The **Cell Periodicity** node has three action buttons on the tool bar of section called **Periodicity Type: Create Load Groups and Study**, **Create Material by Reference**, and **Create Material by Value**. The action button **Create Load Groups and Study** generates load groups and a stationary study with load cases. The action button **Create Material by Reference** generates a **Global Material** with an elasticity matrix corresponding to that of the homogenized material in terms of variables. The action button **Create Material by Value** generates a **Global Material** with an elasticity matrix corresponding to that of the homogenized material in terms of numbers after the study computed. The action buttons are active depending on the choices in the **Periodicity Type** and **Calculate Average Properties** lists.
- Modeling a composite laminated shell requires a surface geometry (2D), in general called a base surface, and a **Layered Material** node which adds an extra dimension (1D) to the base surface geometry in the surface normal direction. Using the **Layered Material** functionality, you can model several layers of different thickness, material properties, and fiber orientations. You can optionally specify the interface materials between the layers and the control mesh elements in each layer.
- The **Layered Material Link** and **Layered Material Stack** have an option to transform the given **Layered Material** into a symmetric or antisymmetric laminate. A repeated laminate can also be constructed using a transform option.
- You can either use the *Layerwise (LW)* theory based **Layered Shell** interface or the *Equivalent Single Layer (ESL)* theory based **Linear Elastic Material, Layered** node in **Shell** interface.
- The built-in **Composites** material library contains data for fiber and matrix constituents as well as for unidirectional and bidirectional laminae.
- To analyze the results in a composite shell, you can either create a slice plot using the **Layered Material Slice** plot for in-plane variation of a quantity, or you can create a **Through Thickness** plot for out-of-plane variation of a quantity at a point. To visualize the results as a 3D solid object, you can use the **Layered Material** dataset which creates a virtual 3D solid object combining the surface geometry (2D) and the extra dimension (1D).

Reference

A. Patil, “Introduction to the Composite Materials Module”, COMSOL Blog, 24 Jan. 2024, <https://www.comsol.com/blogs/introduction-to-the-composite-materials-module/>.

Application Library path: Composite_Materials_Module/Tutorials/
composite_cylinder_micromechanics_and_stress_analysis



Modeling Instructions (Micromechanics)

From the **File** menu, choose **New**.

NEW

In the **New** window, click  **Model Wizard**.

MODEL WIZARD

- 1 In the **Model Wizard** window, click  **3D**.
- 2 In the **Select Physics** tree, select **Structural Mechanics > Solid Mechanics (solid)**.
- 3 Click **Add**.
- 4 Click  **Done**.

GLOBAL DEFINITIONS

Parameters I

- 1 In the **Model Builder** window, under **Global Definitions** click **Parameters I**.
- 2 In the **Settings** window for **Parameters**, locate the **Parameters** section.
- 3 Click  **Load from File**.
- 4 Browse to the model's Application Libraries folder and double-click the file `composite_cylinder_micromechanics_and_stress_analysis_parameters.txt`.
Next, create a repeating unit cell (RUC) for a unidirectional fiber composite with square fiber packing. This RUC like many others can be found in the built-in **Part Libraries**.
- 5 In the **Model Builder** window, right-click **Global Definitions** and choose **Geometry Parts > Part Libraries**.

PART LIBRARIES

- 1 In the **Part Libraries** window, select **COMSOL Multiphysics > Unit Cells and RVEs > Fiber Composites > unidirectional_fiber_square_packing** in the tree.
- 2 Click  **Add to Model**.

- 3 In the **Select Part Variant** dialog, select **Specify fiber volume fraction** in the **Select part variant** list.
- 4 Click **OK**.

GEOMETRY I

Unidirectional Fiber Composite, Square Packing I (pi1)

- 1 In the **Geometry** toolbar, click  **Part Instance** and choose **Unidirectional Fiber Composite, Square Packing**.
- 2 In the **Settings** window for **Part Instance**, locate the **Input Parameters** section.
- 3 In the table, enter the following settings:

Name	Expression	Value	Description
vf	v_f	0.6	Fiber volume fraction
wm	L	0.001 m	Cell width
dm	L	0.001 m	Cell depth
hm	L	0.001 m	Cell height

Form Union (fin)

- 1 In the **Model Builder** window, click **Form Union (fin)**.
- 2 In the **Settings** window for **Form Union/Assembly**, click  **Build Selected**.

SOLID MECHANICS (SOLID)



Linear Elastic Material I

- 1 In the **Model Builder** window, under **Component 1 (comp1) > Solid Mechanics (solid)** click **Linear Elastic Material I**.
- 2 In the **Settings** window for **Linear Elastic Material**, locate the **Linear Elastic Material** section.
- 3 From the **Material symmetry** list, choose **Orthotropic**.

Cell Periodicity I

- 1 In the **Physics** toolbar, click  **Domains** and choose **Cell Periodicity**.
- 2 In the **Settings** window for **Cell Periodicity**, locate the **Periodicity Settings** section.
- 3 From the **Boundary conditions** list, choose **Average strain**.
- 4 Locate the **Effective Properties** section. Select the **Compute density** checkbox.
- 5 Select the **Compute elasticity matrix, standard notation** checkbox.

Boundary Pair 1

- 1 In the **Physics** toolbar, click  **Attributes** and choose **Boundary Pair**.
- 2 In the **Settings** window for **Boundary Pair**, locate the **Boundary Selection** section.
- 3 Click  **Clear Selection**.
- 4 Select Boundaries 1, 5, 11, and 12 only.

Boundary Pair 2

- 1 Right-click **Boundary Pair 1** and choose **Duplicate**.
- 2 In the **Settings** window for **Boundary Pair**, locate the **Boundary Selection** section.
- 3 Click  **Clear Selection**.
- 4 Select Boundaries 2 and 10 only.

Boundary Pair 3

- 1 Right-click **Boundary Pair 2** and choose **Duplicate**.
- 2 In the **Settings** window for **Boundary Pair**, locate the **Boundary Selection** section.
- 3 Click  **Clear Selection**.
- 4 Select Boundaries 3 and 4 only.

In the upper-right corner of the **Periodicity type** section, you can find three buttons **Create Load Groups and Study**, **Create Material by Reference** and **Create Material by Value**. When the **Average strain** option is selected for the computation of the elasticity matrix, you can automatically generate load groups, a study, and a material by clicking on these buttons.

Cell Periodicity 1

- 1 In the **Model Builder** window, click **Cell Periodicity 1**.
- 2 In the **Settings** window for **Cell Periodicity**, click **Automated Model Setup** in the upper-right corner of the **Periodicity Settings** section. From the menu, choose **Create Load Groups and Study** to generate load groups and a study node.

COMSOL Multiphysics is equipped with built-in material properties for a number of composite constituents. Select the needed materials from the **Composites** material folder in the built-in material library.

MATERIALS

Material Link 1: Matrix

- 1 In the **Model Builder** window, under **Component 1 (comp1)** right-click **Materials** and choose **More Materials > Material Link**.

- 2 In the **Settings** window for **Material Link**, type Material Link 1: Matrix in the **Label** text field.
- 3 Locate the **Geometric Entity Selection** section. From the **Selection** list, choose **Matrix (Unidirectional Fiber Composite, Square Packing I)**.
- 4 Locate the **Link Settings** section. Click  **Add Material from Library**.

ADD MATERIAL TO MATERIAL LINK 1: MATRIX (MATLNK1)

- 1 Go to the **Add Material to Material Link 1: Matrix (matlnk1)** window.
- 2 In the tree, select **Composites > Matrix Constituents > Epoxy polymer**.
- 3 Click **OK**.

MATERIALS

Material Link 2: Fiber

- 1 Right-click **Materials** and choose **More Materials > Material Link**.
- 2 In the **Settings** window for **Material Link**, type Material Link 2: Fiber in the **Label** text field.
- 3 Locate the **Geometric Entity Selection** section. From the **Selection** list, choose **Fiber (Unidirectional Fiber Composite, Square Packing I)**.
- 4 Locate the **Link Settings** section. Click  **Add Material from Library**.

ADD MATERIAL TO MATERIAL LINK 2: FIBER (MATLNK2)

- 1 Go to the **Add Material to Material Link 2: Fiber (matlnk2)** window.
- 2 In the tree, select **Composites > Fiber Constituents > T-300 carbon fiber**.
- 3 Click **OK**.

MESH I

Identical Mesh I

In the **Mesh** toolbar, click  **More Attributes** and choose **Identical Mesh**.

Size



- 1 In the **Model Builder** window, click **Size**.
- 2 In the **Settings** window for **Size**, locate the **Element Size** section.
- 3 Click the **Predefined** button.

Identical Mesh I

- 1 In the **Model Builder** window, click **Identical Mesh I**.

- 2 In the **Settings** window for **Identical Mesh**, locate the **First Entity Group** section.
- 3 From the **Selection** list, choose **Pair 1, Source (Unidirectional Fiber Composite, Square Packing 1)**.
- 4 Locate the **Second Entity Group** section. From the **Selection** list, choose **Pair 1, Destination (Unidirectional Fiber Composite, Square Packing 1)**.

Free Triangular 1

- 1 In the **Mesh** toolbar, click  **More Generators** and choose **Free Triangular**.
- 2 In the **Settings** window for **Free Triangular**, locate the **Boundary Selection** section.
- 3 From the **Selection** list, choose **Pair 1, Source (Unidirectional Fiber Composite, Square Packing 1)**.
- 4 Click  **Build Selected**.

Swept 1

- 1 In the **Mesh** toolbar, click  **Swept**.
- 2 In the **Settings** window for **Swept**, click  **Build All**.

CELL PERIODICITY STUDY

In the **Study** toolbar, click  **Compute**.

RESULTS

Stress, Unit Cell

- 1 In the **Settings** window for **3D Plot Group**, type **Stress, Unit Cell** in the **Label** text field.
- 2 In the **Stress, Unit Cell** toolbar, click  **Plot**.

Before you add another physics, create a homogenized material from the **Cell Periodicity** feature.

The homogenized material can be created by using either of the two action buttons in the **Periodicity type** section, **Create Material by Reference** or **Create Material by Value**. Choose the second action button in order to generate the material with numbers.

SOLID MECHANICS (SOLID)

Cell Periodicity 1

- 1 In the **Model Builder** window, under **Component 1 (comp1) > Solid Mechanics (solid)** click **Cell Periodicity 1**.

- 2 In the **Settings** window for **Cell Periodicity**, click **Automated Model Setup** in the upper-right corner of the **Periodicity Settings** section. From the menu, choose **Create Material by Value** to generate a global material node with computed density and elastic properties.

Modeling Instructions (Stress Analysis Using the Layerwise (LW) Theory)



This section describes how to model a laminated composite cylinder using the **Layered Shell** interface based on the layerwise theory.

ADD COMPONENT

In the **Model Builder** window, right-click the root node and choose **Add Component > 3D**.

GEOMETRY 2

Cylinder 1 (cyl1)

- 1 In the **Geometry** toolbar, click  **Cylinder**.
- 2 In the **Settings** window for **Cylinder**, locate the **Object Type** section.
- 3 From the **Type** list, choose **Surface**.
- 4 Locate the **Size and Shape** section. In the **Radius** text field, type r_c .
- 5 In the **Height** text field, type h_c .
- 6 Locate the **Axis** section. From the **Axis type** list, choose **x-axis**.
- 7 Click  **Build Selected**.

DEFINITIONS (COMP2)

Boundary System 2 (sys2)

- 1 In the **Model Builder** window, expand the **Component 2 (comp2) > Definitions** node, then click **Boundary System 2 (sys2)**.
- 2 In the **Settings** window for **Boundary System**, locate the **Settings** section.
- 3 Find the **Coordinate names** subsection. From the **Axis** list, choose **x**.

ADD PHYSICS

- 1 In the **Home** toolbar, click  **Add Physics** to open the **Add Physics** window.
- 2 Go to the **Add Physics** window.
- 3 In the tree, select **Structural Mechanics > Layered Shell (lshell)**.

- 4 Find the **Physics interfaces in study** subsection. In the table, clear the **Solve** checkbox for **Cell Periodicity Study**.
- 5 Click the **Add to Component 2** button in the window toolbar.
- 6 In the **Home** toolbar, click  **Add Physics** to close the **Add Physics** window.

GLOBAL DEFINITIONS

The laminate is antisymmetric when the middle layer is excluded. Therefore, it is sufficient to define only a part of it in the **Layered Material** node. The transformation into the full laminate is performed through layered material settings in the **Layered Material Link** node.

Layered Material: [0/45/90/-45/0]

- 1 In the **Model Builder** window, under **Global Definitions** right-click **Materials** and choose **Layered Material**.
- 2 In the **Settings** window for **Layered Material**, type Layered Material: [0/45/90/-45/0] in the **Label** text field.
- 3 Locate the **Layer Definition** section. In the table, enter the following settings:

Layer	Material	Rotation (deg)	Thickness	Mesh elements
Layer 1	Homogeneous Material (solidcp1mat)	0	th	1

- 4 Click **Add** two times.
- 5 In the table, enter the following settings:

Layer	Material	Rotation (deg)	Thickness	Mesh elements
Layer 2	Homogeneous Material (solidcp1mat)	45	th	1
Layer 3	Homogeneous Material (solidcp1mat)	90	th	1

MATERIALS

Layered Material Link 1 (lmat1)

- 1 In the **Model Builder** window, under **Component 2 (comp2)** right-click **Materials** and choose **Layers > Layered Material Link**.

The laminate, partially defined in the **Layered Material** node, can be transformed into a full laminate using a transform option in the layered material settings. The middle layer is merged in order to create a five layer laminate.

- 2 In the **Settings** window for **Layered Material Link**, locate the **Layered Material Settings** section.
- 3 From the **Transform** list, choose **Antisymmetric**.
- 4 Select the **Merge middle layers** checkbox.
- 5 Click to expand the **Preview Plot Settings** section. In the **Thickness-to-width ratio** text field, type 0.4.
- 6 Locate the **Layered Material Settings** section. Click **Layer Cross-Section Preview** in the upper-right corner of the section to enable the through-thickness view of the laminated material as in [Figure 3](#).
- 7 Click **Layer Stack Preview** in the upper-right corner of the **Layered Material Settings** section to show the stacking sequence including the fiber orientation as in [Figure 4](#).

LAYERED SHELL (LSHELL)

Linear Elastic Material 1

- 1 In the **Model Builder** window, under **Component 2 (comp2)** > **Layered Shell (lshell)** click **Linear Elastic Material 1**.
- 2 In the **Settings** window for **Linear Elastic Material**, locate the **Linear Elastic Material** section.
- 3 From the **Material symmetry** list, choose **Anisotropic**.

Fixed Constraint 1

- 1 In the **Physics** toolbar, click  **Edges** and choose **Fixed Constraint**.
- 2 Select Edges 1, 2, 4, and 6 only.

Roller 1

- 1 In the **Physics** toolbar, click  **Edges** and choose **Roller**.
- 2 Select Edges 9–12 only.

Body Load 1

- 1 In the **Physics** toolbar, click  **Boundaries** and choose **Body Load**.
- 2 Select Boundary 2 only.
- 3 In the **Settings** window for **Body Load**, locate the **Force** section.
- 4 From the **Load type** list, choose **Total force**.
- 5 Specify the \mathbf{F}_{tot} vector as

0	x
0	y
F_{tot}	z

MESH 2



Mapped 1

- 1 In the **Mesh** toolbar, click  **More Generators** and choose **Mapped**.
- 2 In the **Settings** window for **Mapped**, locate the **Boundary Selection** section.
- 3 From the **Selection** list, choose **All boundaries**.

Distribution 1

- 1 Right-click **Mapped 1** and choose **Distribution**.
- 2 In the **Settings** window for **Distribution**, locate the **Edge Selection** section.
- 3 From the **Selection** list, choose **All edges**.
- 4 Locate the **Distribution** section. In the **Number of elements** text field, type 20.
- 5 Click  **Build All**.

ADD STUDY

- 1 In the **Home** toolbar, click  **Add Study** to open the **Add Study** window.
- 2 Go to the **Add Study** window.
- 3 Find the **Studies** subsection. In the **Select Study** tree, select **General Studies > Stationary**.
- 4 Find the **Physics interfaces in study** subsection. In the table, clear the **Solve** checkbox for **Solid Mechanics (solid)**.
- 5 Click the **Add Study** button in the window toolbar.
- 6 In the **Home** toolbar, click  **Add Study** to close the **Add Study** window.

STUDY 1: STATIONARY (LAYERWISE THEORY)

- 1 In the **Settings** window for **Study**, type Study 1: Stationary (Layerwise Theory) in the **Label** text field.
- 2 In the **Study** toolbar, click  **Compute**.

RESULTS

Layered Material

- 1 In the **Model Builder** window, expand the **Results > Datasets** node, then click **Layered Material**.
- 2 In the **Settings** window for **Layered Material**, locate the **Layers** section.
- 3 In the **Scale** text field, type 5.

Cut Point 3D 1

- 1 In the **Results** toolbar, click  **Cut Point 3D**.
- 2 In the **Settings** window for **Cut Point 3D**, locate the **Data** section.
- 3 From the **Dataset** list, choose **Study 1: Stationary (Layerwise Theory)/Solution 1 (3) (sol1)**.
- 4 Locate the **Point Data** section. In the **X** text field, type $hc/2$.
- 5 In the **Y** text field, type rc .
- 6 In the **Z** text field, type rc .
- 7 From the **Snapping** list, choose **Snap to closest boundary**.

Stress (mises)

- 1 In the **Model Builder** window, under **Results** click **Stress (Ishell)**.
- 2 In the **Settings** window for **3D Plot Group**, type Stress (mises) in the **Label** text field.
- 3 Locate the **Plot Settings** section. Clear the **Plot dataset edges** checkbox.
- 4 In the **Stress (mises)** toolbar, click  **Plot**.

RESULT TEMPLATES

- 1 In the **Results** toolbar, click  **Result Templates** to open the **Result Templates** window.
- 2 Go to the **Result Templates** window.
- 3 In the tree, select **Study 1: Stationary (Layerwise Theory)/Solution 1 (3) (sol1) > Layered Shell > Stress, Slice (Ishell)**.
- 4 Click the **Add Result Template** button in the window toolbar.

RESULTS

Stress, Slice (mises)

- 1 In the **Settings** window for **3D Plot Group**, type **Stress, Slice (mises)** in the **Label** text field.
- 2 Locate the **Plot Settings** section. Clear the **Plot dataset edges** checkbox.

Layered Material Slice I

- 1 In the **Model Builder** window, expand the **Stress, Slice (mises)** node, then click **Layered Material Slice I**.
- 2 In the **Settings** window for **Layered Material Slice**, locate the **Through-Thickness Location** section.
- 3 From the **Location definition** list, choose **Layer midplanes**.
- 4 Locate the **Layout** section. From the **Displacement** list, choose **Rectangular**.
- 5 From the **Orientation** list, choose **zx**.
- 6 In the **Relative x-separation** text field, type 0.3.
- 7 In the **Relative z-separation** text field, type 0.7.
- 8 Select the **Show descriptions** checkbox.
- 9 In the **Relative separation** text field, type 0.6.
- 10 Click to expand the **Range** section. Select the **Manual color range** checkbox.
- 11 In the **Minimum** text field, type 0.
- 12 In the **Maximum** text field, type 5e6.
- 13 Click to expand the **Quality** section. From the **Resolution** list, choose **No refinement**.

Deformation

- 1 In the **Model Builder** window, expand the **Layered Material Slice I** node.
- 2 Right-click **Deformation** and choose **Disable**.

Stress, Slice (mises)

- 1 In the **Model Builder** window, under **Results** click **Stress, Slice (mises)**.
- 2 In the **Stress, Slice (mises)** toolbar, click  **Plot**.

RESULT TEMPLATES

- 1 Go to the **Result Templates** window.
- 2 In the tree, select **Study 1: Stationary (Layerwise Theory)/Solution 1 (3) (sol1) > Layered Shell > Stress, Through Thickness (Ishell)**.

3 Click the **Add Result Template** button in the window toolbar.

RESULTS

Stress, Through Thickness (S1m11)

- 1 In the **Settings** window for **ID Plot Group**, type Stress, Through Thickness (S1m11) in the **Label** text field.
- 2 Locate the **Plot Settings** section.
- 3 Select the **x-axis label** checkbox. In the associated text field, type S1m11 (MPa).

Through Thickness I

- 1 In the **Model Builder** window, expand the **Stress, Through Thickness (S1m11)** node, then click **Through Thickness I**.
- 2 In the **Settings** window for **Through Thickness**, locate the **Data** section.
- 3 From the **Dataset** list, choose **Cut Point 3D I**.
- 4 Locate the **x-Axis Data** section. In the **Expression** text field, type 1shell.S1m11.
- 5 From the **Unit** list, choose **MPa**.
- 6 Click to expand the **Legends** section. From the **Legends** list, choose **Manual**.
- 7 In the table, enter the following settings:

Legends
Layerwise Theory

- 8 In the **Stress, Through Thickness (S1m11)** toolbar, click  **Plot**.

RESULT TEMPLATES



- 1 Go to the **Result Templates** window.
- 2 In the tree, select **Study 1: Stationary (Layerwise Theory)/Solution 1 (3) (sol1) > Layered Shell > Geometry and Layup (Ishell) > Thickness and Orientation (Ishell)**.
- 3 Click the **Add Result Template** button in the window toolbar.
- 4 In the tree, select **Study 1: Stationary (Layerwise Theory)/Solution 1 (3) (sol1) > Layered Shell > Geometry and Layup (Ishell) > First Principal Material Direction (Ishell)**.
- 5 Click the **Add Result Template** button in the window toolbar.

RESULTS



Thickness and Orientation (Ishell)

In the **Thickness and Orientation (Ishell)** toolbar, click  **Plot**.

First Principal Material Direction (Ishell)

- 1 In the **Model Builder** window, click **First Principal Material Direction (Ishell)**.
- 2 In the **First Principal Material Direction (Ishell)** toolbar, click  **Plot**.
- 3 Click the  **Zoom Extents** button in the **Graphics** toolbar.

ADD STUDY

- 1 In the **Home** toolbar, click  **Add Study** to open the **Add Study** window.
- 2 Go to the **Add Study** window.
- 3 Find the **Studies** subsection. In the **Select Study** tree, select **General Studies > Eigenfrequency**.
- 4 Find the **Physics interfaces in study** subsection. In the table, clear the **Solve** checkbox for **Solid Mechanics (solid)**.
- 5 Click the **Add Study** button in the window toolbar.
- 6 In the **Home** toolbar, click  **Add Study** to close the **Add Study** window.

STUDY 2: EIGENFREQUENCY (LAYERWISE THEORY)



In the **Settings** window for **Study**, type Study 2: Eigenfrequency (Layerwise Theory) in the **Label** text field.

Step 1: Eigenfrequency

- 1 In the **Model Builder** window, under **Study 2: Eigenfrequency (Layerwise Theory)** click **Step 1: Eigenfrequency**.
- 2 In the **Settings** window for **Eigenfrequency**, locate the **Study Settings** section.
- 3 Select the **Desired number of eigenfrequencies** checkbox. In the associated text field, type 12.
- 4 In the **Study** toolbar, click  **Compute**.

RESULTS



Mode Shape (Layerwise Theory)

- 1 In the **Settings** window for **3D Plot Group**, type Mode Shape (Layerwise Theory) in the **Label** text field.
- 2 Click the  **Zoom Extents** button in the **Graphics** toolbar.
- 3 Locate the **Plot Settings** section. From the **View** list, choose **New view**.
- 4 In the **Mode Shape (Layerwise Theory)** toolbar, click  **Plot**.

Modeling Instructions (Stress Analysis using the Equivalent Single Layer (ESL) Theory)

This section describes how to model a laminated composite cylinder using the **Shell** interface based on the equivalent single layer (ESL) theory.

ADD PHYSICS

- 1 In the **Home** toolbar, click  **Add Physics** to open the **Add Physics** window.
- 2 Go to the **Add Physics** window.
- 3 In the tree, select **Structural Mechanics > Shell (shell)**.
- 4 Find the **Physics interfaces in study** subsection. In the table, clear the **Solve** checkboxes for **Cell Periodicity Study**, **Study 1: Stationary (Layerwise Theory)**, and **Study 2: Eigenfrequency (Layerwise Theory)**.
- 5 Click the **Add to Component 2** button in the window toolbar.
- 6 In the **Home** toolbar, click  **Add Physics** to close the **Add Physics** window.

SHELL (SHELL)

- 1 Click the  **Show More Options** button in the **Model Builder** toolbar.
- 2 In the **Show More Options** dialog, in the tree, select the checkbox for the node **Physics > Advanced Physics Options**.
- 3 Click **OK**.
- 4 In the **Settings** window for **Shell**, click to expand the **Advanced Settings** section.
- 5 Clear the **Use MITC interpolation** checkbox.

Linear Elastic Material, Layered 1

- 1 In the **Physics** toolbar, click  **Boundaries** and choose **Linear Elastic Material, Layered**.
- 2 In the **Settings** window for **Linear Elastic Material, Layered**, locate the **Boundary Selection** section.
- 3 From the **Selection** list, choose **All boundaries**.
- 4 Locate the **Linear Elastic Material** section. From the **Material symmetry** list, choose **Anisotropic**.



Fixed Constraint 1

- 1 In the **Physics** toolbar, click  **Edges** and choose **Fixed Constraint**.
- 2 Select Edges 1, 2, 4, and 6 only.

Symmetry 1



- 1 In the **Physics** toolbar, click  **Edges** and choose **Symmetry**.
- 2 Select Edges 9–12 only.

Face Load 1

- 1 In the **Physics** toolbar, click  **Boundaries** and choose **Face Load**.
- 2 Click the  **Go to Default View** button in the **Graphics** toolbar.
- 3 Select Boundary 2 only.
- 4 In the **Settings** window for **Face Load**, locate the **Force** section.
- 5 From the **Load type** list, choose **Total force**.
- 6 Specify the \mathbf{F}_{tot} vector as

0	x
0	y
F_{tot}	z

ADD STUDY

- 1 In the **Home** toolbar, click  **Add Study** to open the **Add Study** window.
- 2 Go to the **Add Study** window.
- 3 Find the **Studies** subsection. In the **Select Study** tree, select **General Studies > Stationary**.
- 4 Find the **Physics interfaces in study** subsection. In the table, clear the **Solve** checkboxes for **Solid Mechanics (solid)** and **Layered Shell (lshell)**.
- 5 Click the **Add Study** button in the window toolbar.
- 6 In the **Home** toolbar, click  **Add Study** to close the **Add Study** window.

STUDY 3: STATIONARY (ESL THEORY)

- 1 In the **Settings** window for **Study**, type Study 3: Stationary (ESL Theory) in the **Label** text field.
- 2 Locate the **Study Settings** section. Clear the **Generate default plots** checkbox.
- 3 In the **Study** toolbar, click  **Compute**.

RESULTS

Layered Material 1

- 1 In the **Results** toolbar, click  **More Datasets** and choose **Layered Material**.
- 2 In the **Settings** window for **Layered Material**, locate the **Data** section.

- 3 From the **Dataset** list, choose **Study 3: Stationary (ESL Theory)/Solution 3 (7) (sol3)**.
- 4 Locate the **Layers** section. In the **Scale** text field, type 5.

Cut Point 3D 2

- 1 In the **Model Builder** window, under **Results > Datasets** right-click **Cut Point 3D 1** and choose **Duplicate**.
- 2 In the **Settings** window for **Cut Point 3D**, locate the **Data** section.
- 3 From the **Dataset** list, choose **Study 3: Stationary (ESL Theory)/Solution 3 (7) (sol3)**.

Surface 2

- 1 In the **Model Builder** window, expand the **Stress (mises)** node.
- 2 Right-click **Results > Stress (mises) > Surface 1** and choose **Duplicate**.
- 3 In the **Settings** window for **Surface**, locate the **Expression** section.
- 4 In the **Expression** text field, type `shell.mises`.
- 5 Locate the **Data** section. From the **Dataset** list, choose **Layered Material 1**.
- 6 Click to expand the **Title** section. From the **Title type** list, choose **None**.
- 7 Click to expand the **Inherit Style** section. From the **Plot** list, choose **Surface 1**.

Deformation

- 1 In the **Model Builder** window, expand the **Surface 2** node, then click **Deformation**.
- 2 In the **Settings** window for **Deformation**, locate the **Expression** section.
- 3 In the **x-component** text field, type `u3`.
- 4 In the **y-component** text field, type `v3`.
- 5 In the **z-component** text field, type `w3`.

Stress (mises)

In the **Model Builder** window, under **Results** click **Stress (mises)**.

Table Annotation 1

- 1 In the **Stress (mises)** toolbar, click  **More Plots** and choose **Table Annotation**.
- 2 In the **Settings** window for **Table Annotation**, locate the **Data** section.
- 3 From the **Source** list, choose **Local table**.
- 4 In the table, enter the following settings:

x-coordinate	y-coordinate	z-coordinate	Annotation
$-2*hc/5$	0	0	Layerwise Theory
$-2*hc/5$	hc	0	ESL Theory

- 5 Locate the **Coloring and Style** section. Clear the **Show point** checkbox.
- 6 From the **Anchor point** list, choose **Lower middle**.

Stress (mises)

- 1 In the **Model Builder** window, click **Stress (mises)**.
- 2 In the **Settings** window for **3D Plot Group**, click to expand the **Plot Array** section.
- 3 Select the **Enable** checkbox.
- 4 From the **Array axis** list, choose **y**.
- 5 In the **Relative padding** text field, type 1.2.
- 6 In the **Stress (mises)** toolbar, click  **Plot**.



Through Thickness 2

- 1 In the **Model Builder** window, under **Results > Stress, Through Thickness (Slm I 1)** right-click **Through Thickness 1** and choose **Duplicate**.
- 2 In the **Settings** window for **Through Thickness**, locate the **Data** section.
- 3 From the **Dataset** list, choose **Cut Point 3D 2**.
- 4 Locate the **x-Axis Data** section. In the **Expression** text field, type shell.S111.
- 5 Click to expand the **Title** section. From the **Title type** list, choose **None**.
- 6 Click to expand the **Coloring and Style** section. Find the **Line style** subsection. From the **Line** list, choose **Dashed**.
- 7 Locate the **Legends** section. In the table, enter the following settings:

Legends
ESL Theory

- 8 In the **Stress, Through Thickness (Slm I 1)** toolbar, click  **Plot**.

ADD STUDY

- 1 In the **Home** toolbar, click  **Add Study** to open the **Add Study** window.
- 2 Go to the **Add Study** window.
- 3 Find the **Studies** subsection. In the **Select Study** tree, select **General Studies > Eigenfrequency**.
- 4 Find the **Physics interfaces in study** subsection. In the table, clear the **Solve** checkboxes for **Solid Mechanics (solid)** and **Layered Shell (lshell)**.
- 5 Click the **Add Study** button in the window toolbar.
- 6 In the **Home** toolbar, click  **Add Study** to close the **Add Study** window.

STUDY 4: EIGENFREQUENCY (ESL THEORY)

- 1 In the **Settings** window for **Study**, type Study 4: Eigenfrequency (ESL Theory) in the **Label** text field.
- 2 Locate the **Study Settings** section. Clear the **Generate default plots** checkbox.

Step 1: Eigenfrequency

- 1 In the **Model Builder** window, under **Study 4: Eigenfrequency (ESL Theory)** click **Step 1: Eigenfrequency**.
- 2 In the **Settings** window for **Eigenfrequency**, locate the **Study Settings** section.
- 3 Select the **Desired number of eigenfrequencies** checkbox. In the associated text field, type 12.
- 4 In the **Study** toolbar, click  **Compute**.

RESULTS

Layered Material 2a

- 1 In the **Results** toolbar, click  **More Datasets** and choose **Layered Material**.
- 2 In the **Settings** window for **Layered Material**, locate the **Data** section.
- 3 From the **Dataset** list, choose **Study 4: Eigenfrequency (ESL Theory)/Solution 4 (9) (sol4)**.

Mode Shape (ESL Theory)

- 1 In the **Model Builder** window, right-click **Mode Shape (Layerwise Theory)** and choose **Duplicate**.
- 2 In the **Settings** window for **3D Plot Group**, type Mode Shape (ESL Theory) in the **Label** text field.
- 3 Locate the **Data** section. From the **Dataset** list, choose **None**.

Surface 1

- 1 In the **Model Builder** window, expand the **Mode Shape (ESL Theory)** node, then click **Surface 1**.
- 2 In the **Settings** window for **Surface**, locate the **Expression** section.
- 3 In the **Expression** text field, type `shell.disp`.

Deformation

- 1 In the **Model Builder** window, click **Deformation**.
- 2 In the **Settings** window for **Deformation**, locate the **Expression** section.
- 3 In the **x-component** text field, type `u3`.
- 4 In the **y-component** text field, type `v3`.

5 In the **z-component** text field, type w3.

Mode Shape (ESL Theory)

1 In the **Model Builder** window, under **Results** click **Mode Shape (ESL Theory)**.

2 In the **Settings** window for **3D Plot Group**, locate the **Data** section.

3 From the **Dataset** list, choose **Layered Material 2a**.

4 From the **Eigenfrequency (Hz)** list, choose **1212.7**.

5 In the **Mode Shape (ESL Theory)** toolbar, click  **Plot**.

RESULT TEMPLATES

1 Go to the **Result Templates** window.

2 In the tree, select **Study 4: Eigenfrequency (ESL Theory)/Solution 4 (9) (sol4) > Shell > Eigenfrequencies (Study 4: Eigenfrequency (ESL Theory))**.

3 Click the **Add Result Template** button in the window toolbar.

4 In the **Results** toolbar, click  **Result Templates** to close the **Result Templates** window.