

Loudspeaker Driver in a Vented Enclosure

Introduction

This example models the acoustic behavior of a loudspeaker driver mounted in a bass reflex enclosure. The enclosure, sometimes called the cabinet, alters substantially the sensitivity and radiation characteristics of the loudspeaker and it is why it is usually considered part of the integral design of a loudspeaker system.

Two of the most important design parameters for a loudspeaker driver is its sensitivity and the directivity of the system. The sensitivity is commonly defined as the on-axis sound pressure level, measured at a 1 m distance, as the driver is loaded by an AC voltage of 1 W. The directivity is assessed using the *Directivity* plot and represents the spatial sensitivity plotted against the frequency in a contour-like plot.

To isolate the driver's performance from that of the environment it usually operates in, the driver is often set directly in an infinite baffle. This approach is used in another example [Loudspeaker Driver — Frequency-Domain Analysis](#) model in the Acoustics Module Application Library. The model described here solves a full vibroacoustic problem (driver, cabinet, and air domains) and the lumped electromagnetic results (the blocked coil impedance) from the loudspeaker driver example. The model shows how the enclosure affects the response of the loudspeaker.

The model represents the structural components through the *Solid Mechanics* and the *Shell* interfaces applied to the different parts of the loudspeaker (enclosure and driver). The acoustic cavity within the enclosure is modeled with the *Pressure Acoustics, Frequency Domain* interface, while the infinite domain surrounding the enclosure, is modeled with the *Pressure Acoustics, Boundary Elements* interface. The *Acoustic-Structure Boundary* multiphysics coupling is used to connect the different acoustic and structural physics interfaces and the *Acoustic BEM-FEM Boundary* multiphysics coupling is used to couple the interior acoustics to the exterior at the vent.

The model also includes a built-in export option, that shows how the full 3D radiation pattern (the balloon data) of the speaker can be exported in a custom manner.

Note: The model requires the Acoustics Module and the Structural Mechanics Module since it involves the use of the Shell interface.

Model Definition

Figure 1 shows the geometry of the considered driver in an infinite baffle, as modeled in the [Loudspeaker Driver — Frequency-Domain Analysis](#) example. In the model described here, the driver is set in a frame and placed in a bass reflex enclosure (Figure 2). The defining feature of this enclosure type is the vent, which in a properly designed enclosure acts to boost the sound at low frequencies.

Figure 3 shows the driver mounted in the enclosure. The moving parts of the driver are, in the geometry of this model, represented as surfaces rather than thin volumes. This lets you model them as shells, which vastly reduces the number of mesh elements required to resolve the model. Figure 4 displays the complete model geometry; the interior domain, the driver, and the cabinet. The model uses one symmetry in the xz -plane. The exterior

acoustics are modeled with BEM and only require definition on the exterior boundary of the speaker.

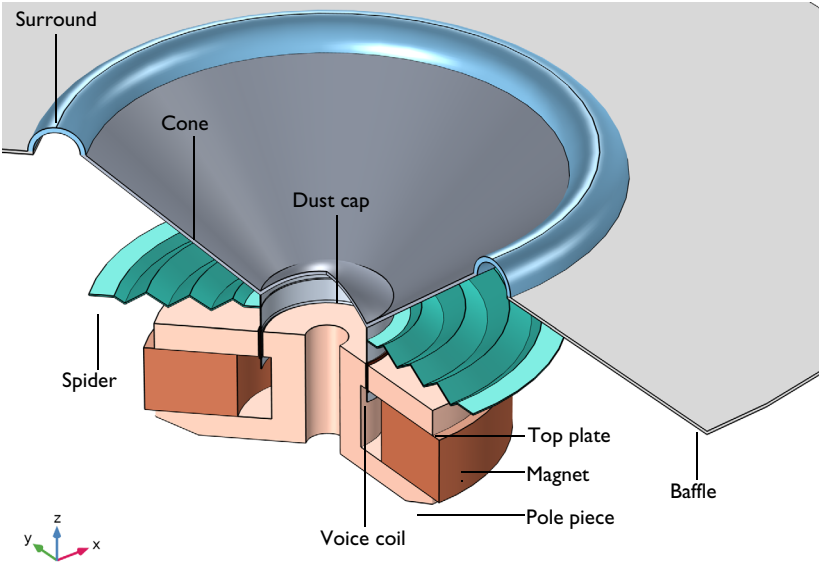

Figure 1: The driver, here set in an infinite baffle as in the loudspeaker driver model.



Figure 2: The basket (left) and the vented enclosure with basket and vent (right).

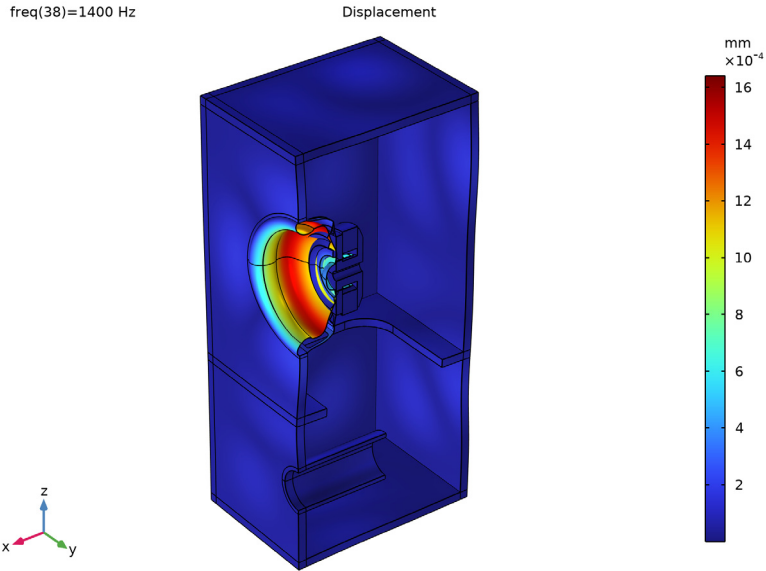

Figure 3: The geometry of the loudspeaker. The enclosure is placed in an anechoic environment (infinite space). The figure also shows the displacements of the structure at 1400 Hz.

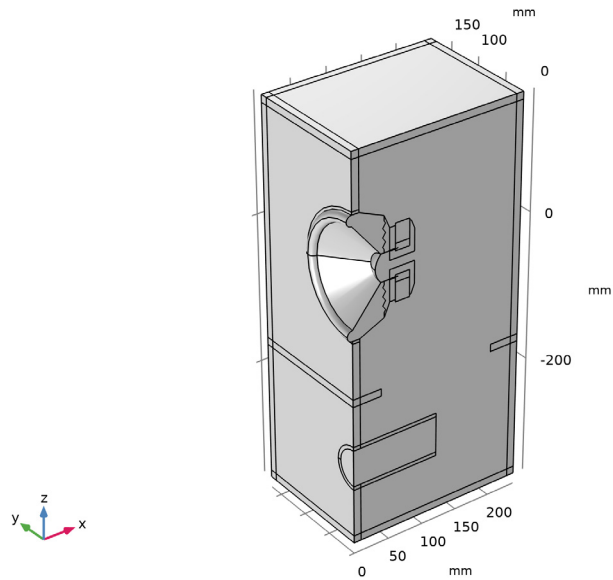

Figure 4: The complete model geometry, symmetry with respect to the xz -plane is used.

The model is driven by a lumped representation of the electromagnetic force acting on the voice coil:

$$F_e = \frac{BLV_0}{Z_b} - v \frac{(BL)^2}{Z_b}$$

The expression is derived in the documentation for the [Loudspeaker Driver — Frequency-Domain Analysis](#) model. BL is the so-called force factor of the voice coil and Z_b is its blocked coil impedance; the electric impedance as measured/simulated when the coil is at stand-still. BL is a constant 10.48 N/A and Z_b is a complex-valued function of the frequency. Both BL and Z_b are taken directly from the [Loudspeaker Driver — Frequency-Domain Analysis](#), the latter through an interpolation function from a `.txt` files with the resistive and inductive contributions listed versus the frequency.

V_0 is the applied driving voltage. The definition of sensitivity assumes a driving power that equals 1 W when the total impedance of the loudspeaker is at its nominal value. The modeled driver has a nominal impedance of 6.3 Ω , which translates to a driving voltage of $V = V_0 e^{i\omega t}$ with the amplitude $V_0 = 3.55$ V (peak voltage). The second term in the expression for the driving force contains the axial velocity of the voice coil v , which is unknown prior to the computation.

The electromagnetic force is applied as opposing forces acting over the voice coil and the permanent magnets in opposite directions. In the model, the total applied force F_e is multiplied with a factor 0.5 as one symmetry is in use (F_e is a total force measured in N, and not a force density). As the cone and the suspension move and deform, their local normal acceleration acts as an acoustic source, while the computed acoustic pressure acts back as a load on the shell and solid. This fully coupled behavior is automatically handled by the *Acoustic-Structure Boundary* multiphysics coupling.

For a discussion of the material and damping parameters used in the moving parts of the driver, see the [Loudspeaker Driver — Frequency-Domain Analysis](#) model documentation.

Results and Discussion

The opposing electromagnetic forces create stresses and strains in all the structural parts, as well as a sound pressure distribution inside and outside the enclosure at all frequencies solved for. As an example of how you can visualize the deformations, [Figure 3](#) includes

them as a deformed surface plot. [Figure 5](#) shows the acoustic pressure distribution on the surfaces of the enclosure and as a slice plot of a portion of the exterior infinite domain.

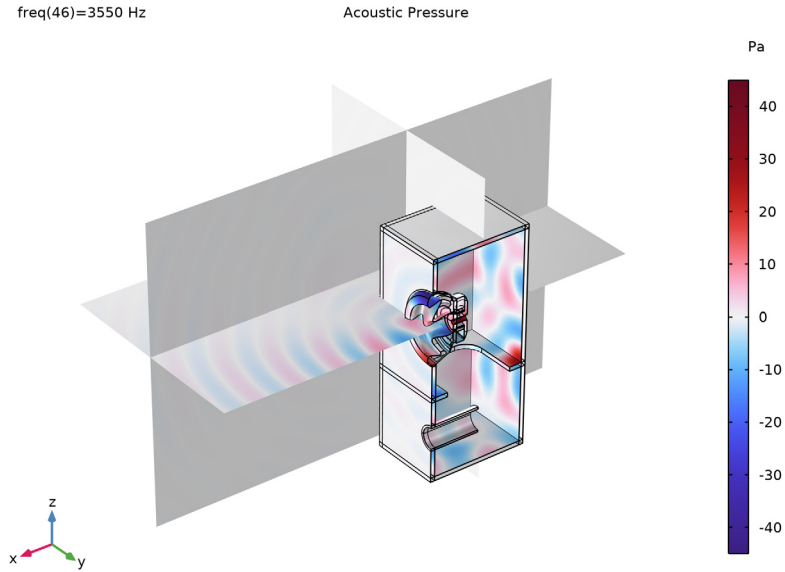

Figure 5: Acoustic pressure at 3550 Hz.

Even though the *Pressure Acoustics, Boundary Elements* interface is only solved for on the boundaries, it is possible to postprocess the solution at any spatial point, as shown in [Figure 5](#) and [Figure 6](#). This makes it possible to, for instance, create slice plots like these two figures or plot the sound pressure level at a given distance versus the elevation angle, or evaluate the directivity as shown in [Figure 7](#).

Figure 6 shows an alternative option, in which the sound pressure level in dB is plotted. Note that the deformation of the cone at this frequency indicates a cone breakup, as discussed in [Loudspeaker Driver — Frequency-Domain Analysis](#).

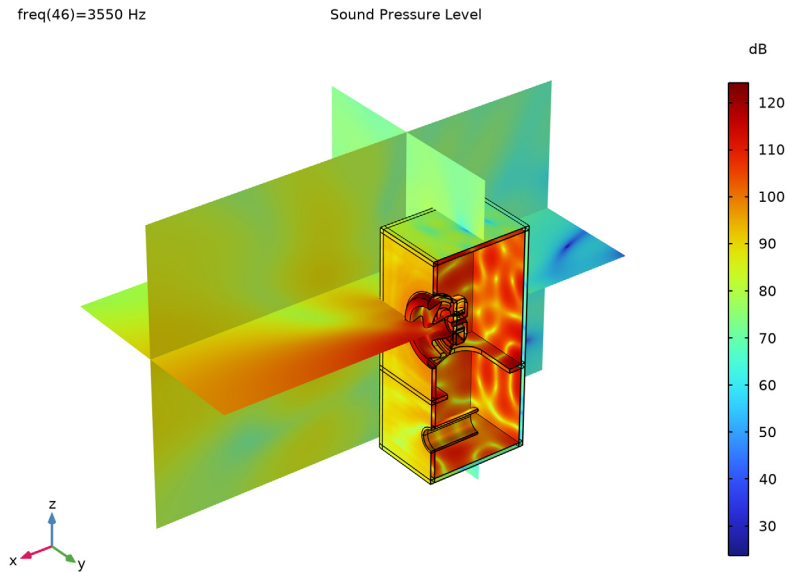

Figure 6: Sound pressure level at 3550 Hz.

Although it is possible to analyze the performance of the loudspeaker by looping through the different pressure plots, a directivity plot can give a good insight into the general performance of the speaker by analyzing some of the features in it. The response of the speaker is evaluated on a circle 1 m around of the speaker, the data is collected for all frequencies and plotted in this contour-like plot. The plot is predefined in the Acoustics Module and is simply called *Directivity*. Figure 7 shows the directivity plot evaluated for a circle of 1 m radius over the xy -plane (horizontal directivity) and the xz -plane (vertical directivity), respectively.

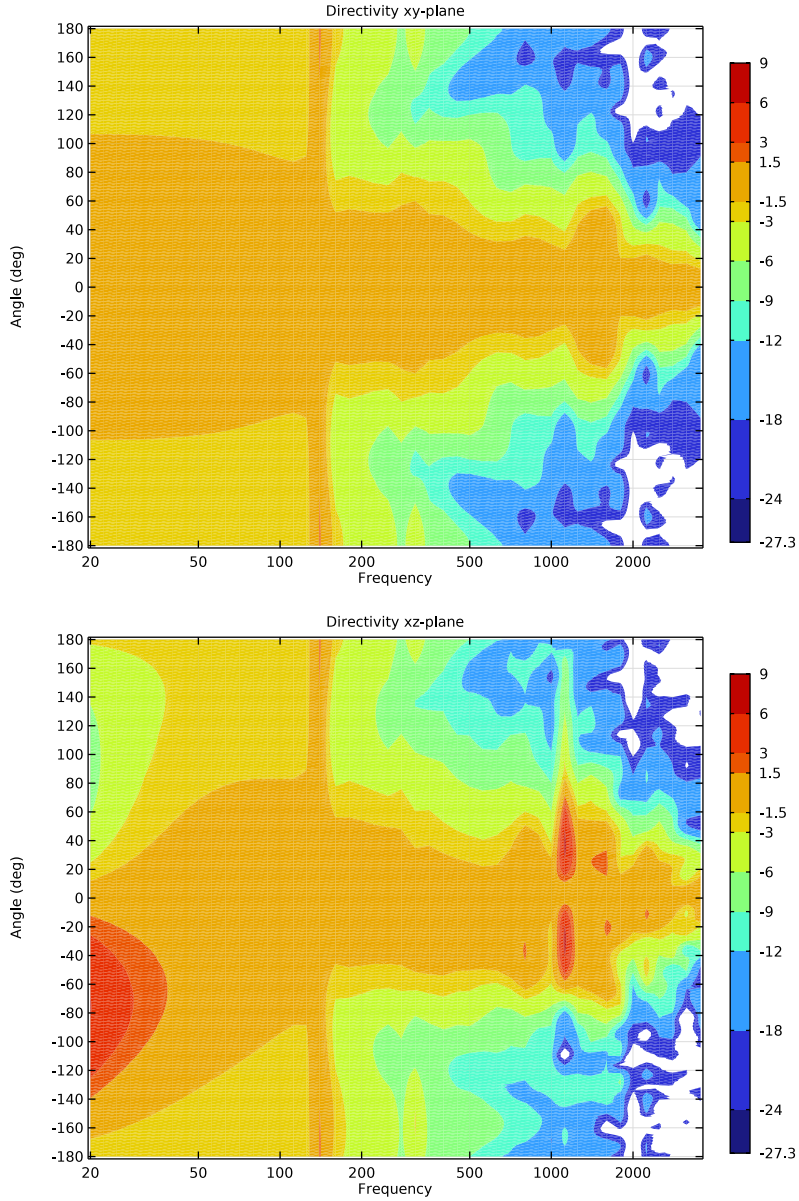

Figure 7: Directivity of the speaker in the *xy*-plane (top) and *xz*-plane (bottom).

These plots reveal that analyzing the loudspeaker in an actual flexible speaker enclosure significantly modifies the directivity characteristics of the loudspeaker. The usual light bulb - flashlight transition appears at a much lower frequency compared to the [Loudspeaker Driver — Frequency-Domain Analysis](#).

The directivity plot in both planes shows a vertical feature around 140 Hz, which indicates that the loudspeaker is radiating in every direction due to a structural mode of the enclosure. The vertical directivity indicates a high directional behavior (vertical dipole) at very low frequencies, which becomes negligible at around 50 Hz. The radiation pattern features can be seen in detail in [Figure 8](#). The plot is also sometimes known as a balloon plot. Beaming behavior can be observed as the frequency increases.

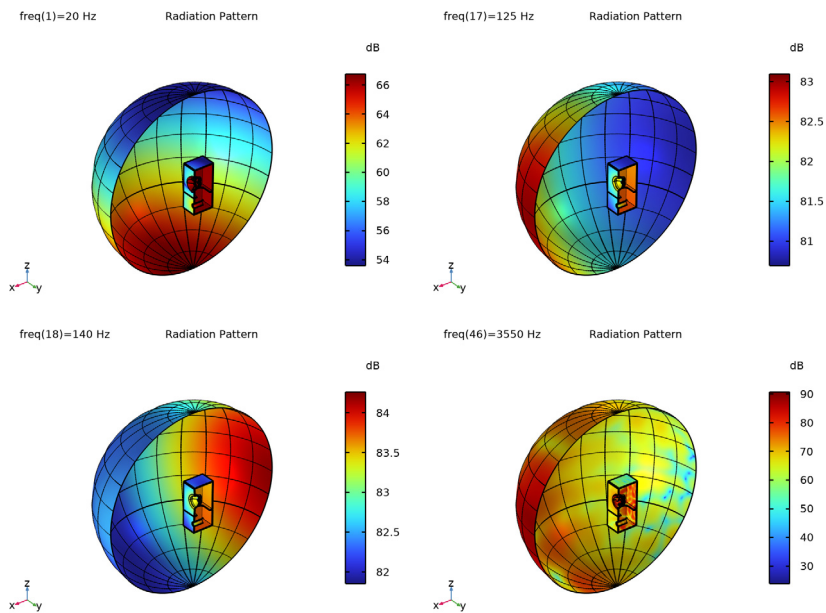

Figure 8: Radiation patterns at 20 Hz, 125 Hz, 140 Hz, and 3550 Hz.

The radiation pattern at 140 Hz in [Figure 8](#) shows that the loudspeaker is radiating more to the back than the front of the speaker, which is quite atypical and indicates the presence of an enclosure structural mode. This mode can also be seen in the mode shape plot in [Figure 12](#), and can also be identified by the stress plot in [Figure 9](#), showing significant stresses in the basket of the loudspeaker. At frequencies close to structural modes, the stress results are completely controlled by the damping of the structural components, so

small changes in the isotropic loss factor can, in the end, mean a large difference in the stress prediction.



Figure 9: Stress distribution at 140 Hz on the basket.

Figure 10 shows how, as the frequency increases, structural modes with shorter wavelengths become excited. These structural modes, studied in detail in [Loudspeaker](#)

Driver — Frequency-Domain Analysis, generate a difference in phase of different parts of the cone which reduce the efficiency of the acoustic radiation of the cone.

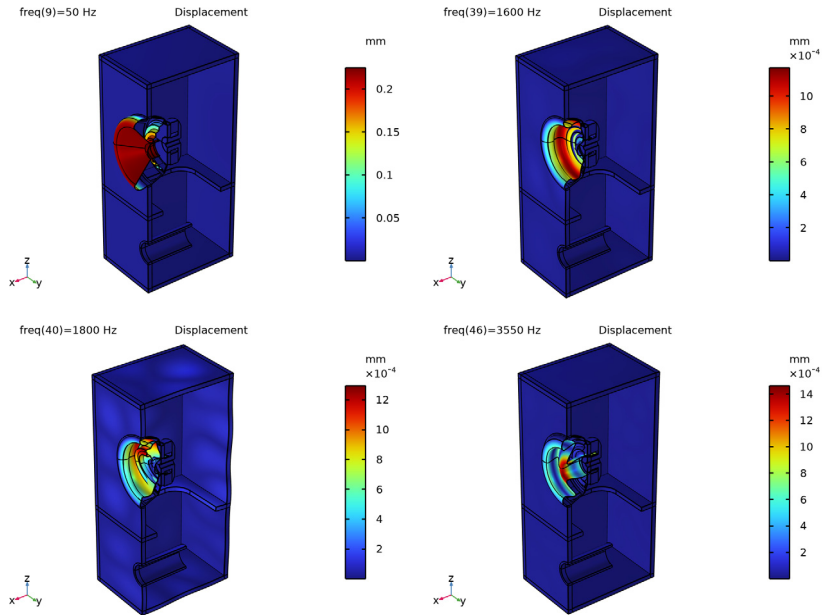

Figure 10: Displacement at 50 Hz, 1600 Hz, 1800 Hz, and 3550 Hz.

The sensitivity of the speaker system is depicted in Figure 11, when the model is solved with a 1/6 octave frequency resolution (the resolution can be increased in the model if necessary). Compared to the sensitivity of the baffled driver alone (Figure 8 in the Loudspeaker Driver — Frequency-Domain Analysis model), adding the enclosure clearly results in a “boost” for all the frequencies. The addition of flexible components around the loudspeaker produces a complex sensitivity response, caused by the many structural

and acoustic modes present. Acoustic features are also visible, like the increased sensitivity around 31.5 Hz which is due to the interaction of the vent and the loudspeaker cone.

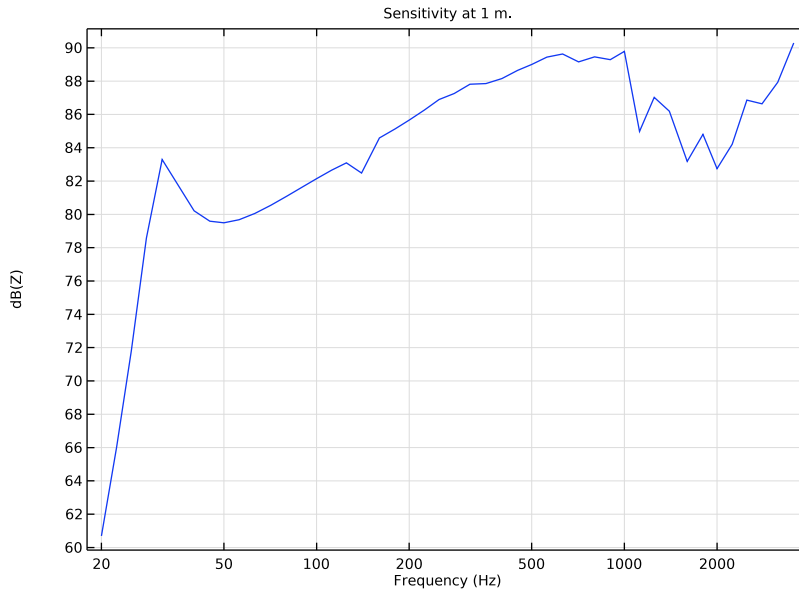

Figure 11: Loudspeaker sensitivity measured as the on-axis sound pressure level (dB) at a distance of 1 m from the unit. The pressure is evaluated using an RMS input signal of 2.51 V, corresponding to a power of 1 W at 6.3 Ω . Note the logarithmic scale for the frequency.

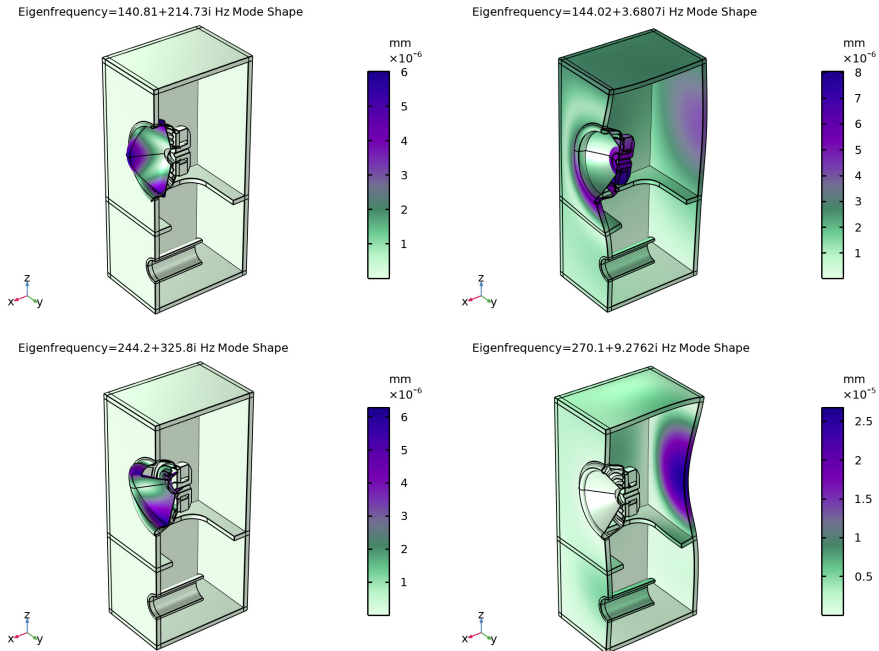

Figure 12: First circumferential mode of the cone (top left), first enclosure mode (top right), first rocking mode of the cone (bottom left), and second enclosure mode (bottom right). These are the main modes influencing the response. The shown modes are modes 1, 2, 6, and 9 from the model.

The last study, in the model, is an eigenfrequency analysis considering only the structural components to identify the modes influencing the performance of the speaker.

As seen in [Figure 12](#), a 3D model is able to capture circumferential and rocking cone modes that will not be possible to analyze through an axisymmetric model like the [Loudspeaker Driver — Frequency-Domain Analysis](#). The flexible enclosure creates additional structural modes that would not be available if the enclosure was considered as rigid. Note that only the modes with one symmetry can be captured, to get the full modal behavior an analysis of the full geometry is necessary.

Notes About the COMSOL Implementation

This model includes an option to export 3D radiation data (the loudspeaker balloon plot) from the loudspeaker for several frequencies. The complex valued pressure (real and

imaginary parts) is chosen in this case, but the sound pressure level and phase can be exported instead if desired.

The exported `.txt` file contains the radiated sound pressure 1 m away from the loudspeaker as a function of frequency f , azimuthal angle ϕ , and inclination angle θ . The resulting radiation data file can then, for example, be imported in a separate Ray Acoustics model to define the directivity of a source using the **Source with Directivity** feature. For an example, see the [Small Concert Hall Acoustics](#) model in the *Acoustics Module Application Library*.

Application Library path: Acoustics_Module/Electroacoustic_Transducers/vented_loudspeaker_enclosure



Modeling Instructions

From the **File** menu, choose **New**.

NEW

In the **New** window, click  **Model Wizard**.



MODEL WIZARD

- 1 In the **Model Wizard** window, click  **3D**.
- 2 In the **Select Physics** tree, select **Acoustics** > **Pressure Acoustics** > **Pressure Acoustics, Frequency Domain (acpr)**.
- 3 Click **Add**.
- 4 In the **Select Physics** tree, select **Acoustics** > **Pressure Acoustics** > **Pressure Acoustics, Boundary Elements (pabe)**.
- 5 Click **Add**.
- 6 In the **Select Physics** tree, select **Structural Mechanics** > **Solid Mechanics (solid)**.
- 7 Click **Add**.
- 8 In the **Select Physics** tree, select **Structural Mechanics** > **Shell (shell)**.
- 9 Click **Add**.
- 10 Click  **Study**.
- 11 In the **Select Study** tree, select **General Studies** > **Frequency Domain**.
- 12 Click  **Done**.



GEOMETRY 1

- 1 In the **Model Builder** window, under **Component 1 (comp1)** click **Geometry 1**.
- 2 In the **Settings** window for **Geometry**, locate the **Units** section.
- 3 From the **Length unit** list, choose **mm**.

Import 1 (imp1)

- 1 In the **Geometry** toolbar, click  **Import**.
- 2 In the **Settings** window for **Import**, locate the **Source** section.
- 3 Click  **Browse**.
- 4 Browse to the model's Application Libraries folder and double-click the file `vented_loudspeaker_enclosure.mphbin`.
- 5 Click  **Import**.

Rotate 1 (rot1)

- 1 In the **Geometry** toolbar, click  **Transforms** and choose **Rotate**.
- 2 Select the object **imp1** only.
- 3 In the **Settings** window for **Rotate**, locate the **Rotation** section.
- 4 In the **Angle** text field, type 180.
- 5 In the **Geometry** toolbar, click  **Build All**.

DEFINITIONS

To make it easier to select some important sets of domains and boundaries in a complicated geometry such as the one you are looking at, it is good modeling practice to begin by defining selections. When working on your own model, these selections are most conveniently defined by clicking and selecting directly in the geometry. The instructions however refer to them by numbers. Whenever a selection is made, it is therefore recommended that you use the Paste Selection button. Enter the number or list of numbers in the text field that appears. Input such as 5, 5-8, 13, or 4, 7, and 9 is accepted.

View 2

- 1 In the **Model Builder** window, expand the **Component 1 (comp1) > Definitions** node.
- 2 Right-click **Definitions** and choose **View**.
- 3 In the **Settings** window for **View**, locate the **View** section.
- 4 Select the **Lock camera** checkbox.
- 5 Select the **Lock rotation center** checkbox.



Camera

- 1 In the **Model Builder** window, expand the **View 2** node, then click **Camera**.
- 2 In the **Settings** window for **Camera**, locate the **Position** section.
- 3 In the **x** text field, type 1505.2598876953125.
- 4 In the **y** text field, type 2077.179931640625.
- 5 Locate the **Target** section. In the **x** text field, type -116.375.
- 6 In the **y** text field, type -85.
- 7 Locate the **Up Vector** section. In the **x** text field, type -0.3086974024772644.
- 8 In the **y** text field, type -0.4115965962409973.
- 9 Click  **Update**.

All Domains

- 1 In the **Definitions** toolbar, click  **Explicit**.
- 2 In the **Settings** window for **Explicit**, type All Domains in the **Label** text field.
- 3 Locate the **Input Entities** section. Select the **All domains** checkbox.

Coil

- 1 In the **Definitions** toolbar, click  **Explicit**.
- 2 In the **Settings** window for **Explicit**, type Coil in the **Label** text field.
- 3 Click the  **Wireframe Rendering** button in the **Graphics** toolbar.

With wireframe rendering, you can see through boundaries and get a better view of which ones you are selecting.

- 4 Select Domain 26 only.

Narrow Region Inner

- 1 In the **Definitions** toolbar, click  **Explicit**.
- 2 In the **Settings** window for **Explicit**, type Narrow Region Inner in the **Label** text field.
- 3 Select Domain 29 only.

Narrow Region Outer

- 1 In the **Definitions** toolbar, click  **Explicit**.
- 2 In the **Settings** window for **Explicit**, type Narrow Region Outer in the **Label** text field.
- 3 Select Domain 28 only.

Soft Iron

- 1 In the **Definitions** toolbar, click  **Explicit**.

- 2 In the **Settings** window for **Explicit**, type Soft Iron in the **Label** text field.
- 3 Select Domains 23 and 27 only.

Ferrite

- 1 In the **Definitions** toolbar, click  **Explicit**.
- 2 In the **Settings** window for **Explicit**, type Ferrite in the **Label** text field.
- 3 Select Domain 24 only.

Enclosure

- 1 In the **Definitions** toolbar, click  **Explicit**.
- 2 In the **Settings** window for **Explicit**, type Enclosure in the **Label** text field.
- 3 Select Domains 1–16, 18–21, and 30–42 only.

Air Domains

- 1 In the **Definitions** toolbar, click  **Difference**.
- 2 In the **Settings** window for **Difference**, type Air Domains in the **Label** text field.
- 3 Locate the **Input Entities** section. Under **Selections to add**, click **+ Add**.
- 4 In the **Add** dialog, select **All Domains** in the **Selections to add** list.
- 5 Click **OK**.
- 6 In the **Settings** window for **Difference**, locate the **Input Entities** section.
- 7 Under **Selections to subtract**, click **+ Add**.
- 8 In the **Add** dialog, in the **Selections to subtract** list, choose **Coil, Soft Iron, Ferrite, and Enclosure**.
- 9 Click **OK**.

Structural Domains

- 1 In the **Definitions** toolbar, click  **Union**.
- 2 In the **Settings** window for **Union**, type Structural Domains in the **Label** text field.
- 3 Locate the **Input Entities** section. Under **Selections to add**, click **+ Add**.
- 4 In the **Add** dialog, in the **Selections to add** list, choose **Coil, Soft Iron, Ferrite, and Enclosure**.
- 5 Click **OK**.

Swept Domains

- 1 In the **Definitions** toolbar, click  **Union**.
- 2 In the **Settings** window for **Union**, type Swept Domains in the **Label** text field.

- 3 Locate the **Input Entities** section. Under **Selections to add**, click **+ Add**.
- 4 In the **Add** dialog, in the **Selections to add** list, choose **Coil**, **Narrow Region Inner**, **Narrow Region Outer**, and **Enclosure**.
- 5 Click **OK**.

All Boundaries

- 1 In the **Definitions** toolbar, click  **Explicit**.
- 2 In the **Settings** window for **Explicit**, type All Boundaries in the **Label** text field.
- 3 Locate the **Input Entities** section. From the **Geometric entity level** list, choose **Boundary**.
- 4 Select the **All boundaries** checkbox.

Composite

- 1 In the **Definitions** toolbar, click  **Explicit**.
- 2 In the **Settings** window for **Explicit**, type Composite in the **Label** text field.
- 3 Locate the **Input Entities** section. From the **Geometric entity level** list, choose **Boundary**.
- 4 Select Boundaries 199–202 only.

Cloth

- 1 In the **Definitions** toolbar, click  **Explicit**.
- 2 In the **Settings** window for **Explicit**, type Cloth in the **Label** text field.
- 3 Locate the **Input Entities** section. From the **Geometric entity level** list, choose **Boundary**.
- 4 Select Boundaries 173–184, 187, 188, and 191–194 only.

Foam

- 1 In the **Definitions** toolbar, click  **Explicit**.
- 2 In the **Settings** window for **Explicit**, type Foam in the **Label** text field.
- 3 Locate the **Input Entities** section. From the **Geometric entity level** list, choose **Boundary**.
- 4 Select Boundaries 271–274 only.

Glass Fiber

- 1 In the **Definitions** toolbar, click  **Explicit**.
- 2 In the **Settings** window for **Explicit**, type Glass Fiber in the **Label** text field.
- 3 Locate the **Input Entities** section. From the **Geometric entity level** list, choose **Boundary**.
- 4 Select Boundaries 115, 116, 121, 122, 141, 142, 163, 164, 171, 172, 195, and 196 only.

Basket

- 1 In the **Definitions** toolbar, click  **Explicit**.
- 2 In the **Settings** window for **Explicit**, type **Basket** in the **Label** text field.
- 3 Locate the **Input Entities** section. From the **Geometric entity level** list, choose **Boundary**.
- 4 Select Boundaries 129, 130, 155, 156, 189, 190, 239, 240, 269, and 270 only.



Other Mapped Boundaries

- 1 In the **Definitions** toolbar, click  **Explicit**.
- 2 In the **Settings** window for **Explicit**, type **Other Mapped Boundaries** in the **Label** text field.
- 3 Locate the **Input Entities** section. From the **Geometric entity level** list, choose **Boundary**.
- 4 Select Boundaries 124, 150, 151, 239, 240, 259–264, 266, 268–270, 275, and 276 only.

Not Mapped Boundaries

- 1 In the **Definitions** toolbar, click  **Explicit**.
- 2 In the **Settings** window for **Explicit**, type **Not Mapped Boundaries** in the **Label** text field.
- 3 Locate the **Input Entities** section. From the **Geometric entity level** list, choose **Boundary**.
- 4 Select Boundaries 195 and 196 only.

Shell Domains

- 1 In the **Definitions** toolbar, click  **Union**.
- 2 In the **Settings** window for **Union**, type **Shell Domains** in the **Label** text field.
- 3 Locate the **Geometric Entity Level** section. From the **Level** list, choose **Boundary**.
- 4 Locate the **Input Entities** section. Under **Selections to add**, click  **Add**.
- 5 In the **Add** dialog, in the **Selections to add** list, choose **Composite, Cloth, Foam, Glass Fiber,** and **Basket**.
- 6 Click **OK**.

Symmetry Boundaries

- 1 In the **Definitions** toolbar, click  **Box**.
- 2 In the **Settings** window for **Box**, type **Symmetry Boundaries** in the **Label** text field.
- 3 Locate the **Geometric Entity Level** section. From the **Level** list, choose **Boundary**.
- 4 Locate the **Box Limits** section. In the **y minimum** text field, type 0.
- 5 Locate the **Output Entities** section. From the **Include entity if** list, choose **Entity inside box**.

Boundaries out of Symmetry Plane

- 1 In the **Definitions** toolbar, click  **Difference**.
- 2 In the **Settings** window for **Difference**, type Boundaries out of Symmetry Plane in the **Label** text field.
- 3 Locate the **Geometric Entity Level** section. From the **Level** list, choose **Boundary**.
- 4 Locate the **Input Entities** section. Under **Selections to add**, click **+ Add**.
- 5 In the **Add** dialog, select **All Boundaries** in the **Selections to add** list.
- 6 Click **OK**.
- 7 In the **Settings** window for **Difference**, locate the **Input Entities** section.
- 8 Under **Selections to subtract**, click **+ Add**.
- 9 In the **Add** dialog, select **Symmetry Boundaries** in the **Selections to subtract** list.
- 10 Click **OK**.

Mapped Boundaries

- 1 In the **Definitions** toolbar, click  **Difference**.
- 2 In the **Settings** window for **Difference**, type Mapped Boundaries in the **Label** text field.
- 3 Locate the **Geometric Entity Level** section. From the **Level** list, choose **Boundary**.
- 4 Locate the **Input Entities** section. Under **Selections to add**, click **+ Add**.
- 5 In the **Add** dialog, in the **Selections to add** list, choose **Cloth, Foam, Glass Fiber**, and **Other Mapped Boundaries**.
- 6 Click **OK**.
- 7 In the **Settings** window for **Difference**, locate the **Input Entities** section.
- 8 Under **Selections to subtract**, click **+ Add**.
- 9 In the **Add** dialog, select **Not Mapped Boundaries** in the **Selections to subtract** list.
- 10 Click **OK**.



Symmetry Edges

- 1 In the **Definitions** toolbar, click  **Box**.
- 2 In the **Settings** window for **Box**, type Symmetry Edges in the **Label** text field.
- 3 Locate the **Geometric Entity Level** section. From the **Level** list, choose **Edge**.
- 4 Locate the **Box Limits** section. In the **y minimum** text field, type 0.

- 5 Locate the **Output Entities** section. From the **Include entity if** list, choose **Entity inside box**.

Next, define interpolation functions to bring in the blocked resistance and inductance from the model of the driver.

Interpolation 1 (int1)



- 1 In the **Definitions** toolbar, click  **Interpolation**.
- 2 In the **Settings** window for **Interpolation**, locate the **Definition** section.
- 3 From the **Data source** list, choose **File**.
- 4 Click  **Browse**.
- 5 Browse to the model's Application Libraries folder and double-click the file `vented_loudspeaker_enclosure_Rb.txt`.
- 6 Click  **Import**.
- 7 In the **Function name** text field, type `Rb`.
- 8 Locate the **Units** section. In the **Argument** table, enter the following settings:

Argument	Unit
t	Hz

- 9 In the **Function** table, enter the following settings:

Function	Unit
Rb	ohm

Interpolation 2 (int2)

- 1 In the **Definitions** toolbar, click  **Interpolation**.
- 2 In the **Settings** window for **Interpolation**, locate the **Definition** section.
- 3 From the **Data source** list, choose **File**.
- 4 Click  **Browse**.
- 5 Browse to the model's Application Libraries folder and double-click the file `vented_loudspeaker_enclosure_Lb.txt`.
- 6 Click  **Import**.
- 7 In the **Function name** text field, type `Lb`.

8 Locate the **Units** section. In the **Argument** table, enter the following settings:

Argument	Unit
t	Hz

9 In the **Function** table, enter the following settings:

Function	Unit
Lb	H

To enable extraction of the velocity, define an average operator acting on the voice coil.

Average I (aveopI)

- 1 In the **Definitions** toolbar, click  **Nonlocal Couplings** and choose **Average**.
- 2 In the **Settings** window for **Average**, type av_coil in the **Operator name** text field.
- 3 Locate the **Source Selection** section. From the **Selection** list, choose **Coil**.

GLOBAL DEFINITIONS

Define parameters for the driving voltage, the BL factor from the loudspeaker driver model, the frequency at which the material losses are specified, and the wavelength at 3550 Hz (used to set the mesh size).

Parameters I

- 1 In the **Model Builder** window, under **Global Definitions** click **Parameters I**.
- 2 In the **Settings** window for **Parameters**, locate the **Parameters** section.
- 3 In the table, enter the following settings:

Name	Expression	Value	Description
V0	3.55[V]	3.55 V	Driving Voltage
BL	10.48[N/A]	10.48 Wb/m	Force factor from loudspeaker driver model
f_loss	40[Hz]	40 Hz	Frequency at which loss factor is given
omega_loss	2*pi*f_loss	251.33 Hz	Angular frequency at which loss factor is given
fmax	3.55[kHz]	3550 Hz	Maximal study frequency
c0	343[m/s]	343 m/s	Speed of sound in air
lam0	c0/fmax	0.09662 m	Minimum wave length

DEFINITIONS

Next, create the expressions used in defining the electric driving force. The Description field is optional, but helps you keep track of what you are doing.

Variables /

- 1 In the **Definitions** toolbar, click  **Local Variables**.
- 2 In the **Settings** window for **Variables**, locate the **Variables** section.
- 3 In the table, enter the following settings:

Name	Expression	Unit	Description
v0	av_coil(solid.u_tX)	m/s	Coil velocity
Zb	Rb(freq)+acpr.iomega* Lb(freq)	Ω	Blocked coil impedance
Fe	BL*v0/Zb-v0*BL^2/Zb	N·m/m	Electric driving force

MATERIALS

While the material properties used in this model are partly made up, they resemble those used in a real driver. The coil former has properties representative of glass fiber materials. The spider, acting as a spring, is made of a phenolic cloth with a much lower stiffness. The material used in the coil is taken to be lighter than copper, as the wire is insulated and does not completely fill the coil domain. The surround, finally, is a light resistive foam.

Except for air and soft iron, the materials you will use all come from a material library created especially for this model (to be loaded from the file `loudspeaker_driver_materials.mph`). You may notice that some of the materials will report missing properties. For example, the composite does not include any electromagnetic properties. This is fine, as you will not model the magnetic fields in the domains where the composite is used.

ADD MATERIAL

- 1 In the **Materials** toolbar, click  **Add Material** to open the **Add Material** window.
 - 2 Go to the **Add Material** window.
 - 3 In the tree, select **Built-in > Air**.
 - 4 Click the **Add to Component** button in the window toolbar.
 - 5 In the tree, select **Built-in > Structural steel**.
 - 6 Click the **Add to Component** button in the window toolbar.
- Add this material twice as it will be used in both the Solid and Shell physics interfaces.

- 7 In the tree, select **Built-in > Structural steel**.
- 8 Click the **Add to Component** button in the window toolbar.

MATERIALS



Structural steel 1 (mat3)

In the **Model Builder** window, under **Component 1 (comp1) > Materials** right-click **Structural steel 1 (mat3)** and choose **Browse Materials**.

MATERIAL BROWSER

- 1 In the **Material Browser** window, In the ribbon make sure to select the **Materials** tab and then click the **Browse Materials** icon.

The **Import Material Library** functionality is activated by clicking the small icon at the lower-right, below the **Material Browser** tree.

- 2 click  **Import Material Library**.
- 3 Browse to the model's Application Libraries folder and double-click the file `loudspeaker_driver_materials.mph`.
- 4 Click  **Done**.

ADD MATERIAL

- 1 Go to the **Add Material** window.
- 2 In the tree, select **loudspeaker driver materials > Composite**.
- 3 Click the **Add to Component** button in the window toolbar.
- 4 In the tree, select **loudspeaker driver materials > Cloth**.
- 5 Click the **Add to Component** button in the window toolbar.
- 6 In the tree, select **loudspeaker driver materials > Foam**.
- 7 Click the **Add to Component** button in the window toolbar.
- 8 In the tree, select **loudspeaker driver materials > Coil**.
- 9 Click the **Add to Component** button in the window toolbar.
- 10 In the tree, select **loudspeaker driver materials > Glass Fiber**.
- 11 Click the **Add to Component** button in the window toolbar.
- 12 In the tree, select **loudspeaker driver materials > Generic Ferrite**.
- 13 Click the **Add to Component** button in the window toolbar.
- 14 In the tree, select **loudspeaker driver materials > Fiberboard**.
- 15 Click the **Add to Component** button in the window toolbar.

16 In the **Materials** toolbar, click  **Add Material** to close the **Add Material** window.

MATERIALS

Air (mat1)

- 1 In the **Settings** window for **Material**, locate the **Geometric Entity Selection** section.
- 2 From the **Selection** list, choose **All domains and voids**.

Structural steel (mat2)

- 1 In the **Model Builder** window, click **Structural steel (mat2)**.
- 2 In the **Settings** window for **Material**, locate the **Geometric Entity Selection** section.
- 3 From the **Selection** list, choose **Soft Iron**.

Structural steel I (mat3)

- 1 In the **Model Builder** window, click **Structural steel I (mat3)**.
- 2 In the **Settings** window for **Material**, locate the **Geometric Entity Selection** section.
- 3 From the **Geometric entity level** list, choose **Boundary**.
- 4 From the **Selection** list, choose **Basket**.

Composite (mat4)

- 1 In the **Model Builder** window, click **Composite (mat4)**.
- 2 In the **Settings** window for **Material**, locate the **Geometric Entity Selection** section.
- 3 From the **Geometric entity level** list, choose **Boundary**.
- 4 From the **Selection** list, choose **Composite**.

Cloth (mat5)

- 1 In the **Model Builder** window, click **Cloth (mat5)**.
- 2 In the **Settings** window for **Material**, locate the **Geometric Entity Selection** section.
- 3 From the **Geometric entity level** list, choose **Boundary**.
- 4 From the **Selection** list, choose **Cloth**.

Foam (mat6)

- 1 In the **Model Builder** window, click **Foam (mat6)**.
- 2 In the **Settings** window for **Material**, locate the **Geometric Entity Selection** section.
- 3 From the **Geometric entity level** list, choose **Boundary**.
- 4 From the **Selection** list, choose **Foam**.

Coil (mat7)

- 1 In the **Model Builder** window, click **Coil (mat7)**.
- 2 In the **Settings** window for **Material**, locate the **Geometric Entity Selection** section.
- 3 From the **Selection** list, choose **Coil**.

Glass Fiber (mat8)

- 1 In the **Model Builder** window, click **Glass Fiber (mat8)**.
- 2 In the **Settings** window for **Material**, locate the **Geometric Entity Selection** section.
- 3 From the **Geometric entity level** list, choose **Boundary**.
- 4 From the **Selection** list, choose **Glass Fiber**.

Generic Ferrite (mat9)

- 1 In the **Model Builder** window, click **Generic Ferrite (mat9)**.
- 2 In the **Settings** window for **Material**, locate the **Geometric Entity Selection** section.
- 3 From the **Selection** list, choose **Ferrite**.

Fiberboard (mat10)

- 1 In the **Model Builder** window, click **Fiberboard (mat10)**.
- 2 In the **Settings** window for **Material**, locate the **Geometric Entity Selection** section.
- 3 From the **Selection** list, choose **Enclosure**.

With the materials defined, it is now time to set up the remaining physics of the model. Begin by specifying the symmetry condition in the acoustics domain.

PRESSURE ACOUSTICS, FREQUENCY DOMAIN (ACPR)

- 1 In the **Model Builder** window, under **Component 1 (comp1)** click **Pressure Acoustics, Frequency Domain (acpr)**.
- 2 In the **Settings** window for **Pressure Acoustics, Frequency Domain**, locate the **Domain Selection** section.
- 3 From the **Selection** list, choose **Air Domains**.

Symmetry 1

- 1 In the **Physics** toolbar, click  **Boundaries** and choose **Symmetry**.
- 2 In the **Settings** window for **Symmetry**, locate the **Boundary Selection** section.
- 3 From the **Selection** list, choose **Symmetry Boundaries**.

Next add the **Narrow Region Acoustics** features to account for the losses in the domains surrounding the voice coil. The values of the slit heights are taken from the 2D

Axisymmetric model and differ from the measurements of the geometry, as the thickness of the coil former is not specifically captured in the geometry.

Narrow Region Acoustics 1

- 1 In the **Physics** toolbar, click  **Domains** and choose **Narrow Region Acoustics**.
- 2 In the **Settings** window for **Narrow Region Acoustics**, locate the **Domain Selection** section.
- 3 From the **Selection** list, choose **Narrow Region Inner**.
- 4 Locate the **Duct Properties** section. From the **Duct type** list, choose **Slit**.
- 5 In the h text field, type 0.4[mm].

Narrow Region Acoustics 2

- 1 In the **Physics** toolbar, click  **Domains** and choose **Narrow Region Acoustics**.
- 2 In the **Settings** window for **Narrow Region Acoustics**, locate the **Domain Selection** section.
- 3 From the **Selection** list, choose **Narrow Region Outer**.
- 4 Locate the **Duct Properties** section. From the **Duct type** list, choose **Slit**.
- 5 In the h text field, type 0.2[mm].

The **Pressure Acoustics, Boundary Elements** interface lets you compute the pressure field (including phase) at any finite distance from the loudspeaker. Specify the symmetry condition of the xz -plane.

PRESSURE ACOUSTICS, BOUNDARY ELEMENTS (PABE)

- 1 In the **Model Builder** window, under **Component 1 (comp1)** click **Pressure Acoustics, Boundary Elements (pabe)**.
- 2 In the **Settings** window for **Pressure Acoustics, Boundary Elements**, locate the **Domain Selection** section.
- 3 From the **Selection** list, choose **All voids**.
- 4 Click to expand the **Symmetry/Infinite Boundary Condition** section. From the **Condition for the $y = y_0$ plane** list, choose **Symmetric/Infinite sound hard boundary**.

SOLID MECHANICS (SOLID)

- 1 In the **Model Builder** window, under **Component 1 (comp1)** click **Solid Mechanics (solid)**.
- 2 In the **Settings** window for **Solid Mechanics**, locate the **Domain Selection** section.
- 3 From the **Selection** list, choose **Structural Domains**.

Symmetry 1

- 1 In the **Physics** toolbar, click  **Boundaries** and choose **Symmetry**.

- 2 In the **Settings** window for **Symmetry**, locate the **Boundary Selection** section.
- 3 From the **Selection** list, choose **Symmetry Boundaries**.

Linear Elastic Material 1

In the **Model Builder** window, click **Linear Elastic Material 1**.

Damping 1

- 1 In the **Physics** toolbar, click  **Attributes** and choose **Damping**.
- 2 In the **Settings** window for **Damping**, locate the **Damping Settings** section.
- 3 From the **Damping type** list, choose **Isotropic loss factor**.

Next, apply the opposing electromagnetic forces acting onto the coil and the soft iron. The reaction force on the magnetic circuit only has a minor influence on the response as the magnet system is much heavier than the speaker cone. Also, due to the use of symmetry in the model, remember to multiply the force with 0.5 as you apply a total force.

Body Load 1

- 1 In the **Physics** toolbar, click  **Domains** and choose **Body Load**.
- 2 In the **Settings** window for **Body Load**, locate the **Domain Selection** section.
- 3 From the **Selection** list, choose **Soft Iron**.
- 4 Locate the **Force** section. From the **Load type** list, choose **Total force**.
- 5 Specify the \mathbf{F}_{tot} vector as

-0.5*Fe	x
0	y
0	z

Body Load 2

- 1 In the **Physics** toolbar, click  **Domains** and choose **Body Load**.
- 2 In the **Settings** window for **Body Load**, locate the **Domain Selection** section.
- 3 From the **Selection** list, choose **Coil**.
- 4 Locate the **Force** section. From the **Load type** list, choose **Total force**.
- 5 Specify the \mathbf{F}_{tot} vector as

0.5*Fe	x
0	y
0	z

Now set up the shell physics. Begin by specifying the individual thicknesses and damping properties of the moving parts of the driver.

SHELL (SHELL)

- 1 In the **Model Builder** window, under **Component 1 (comp1)** click **Shell (shell)**.
- 2 In the **Settings** window for **Shell**, locate the **Boundary Selection** section.
- 3 From the **Selection** list, choose **Shell Domains**.

Linear Elastic Material 1

In the **Model Builder** window, under **Component 1 (comp1) > Shell (shell)** click **Linear Elastic Material 1**.

Damping 1

- 1 In the **Physics** toolbar, click  **Attributes** and choose **Damping**.
- 2 In the **Settings** window for **Damping**, locate the **Boundary Selection** section.
- 3 From the **Selection** list, choose **Shell Domains**.
- 4 Locate the **Damping Settings** section. From the **Damping type** list, choose **Isotropic loss factor**.

Linear Elastic Material 1

In the **Model Builder** window, click **Linear Elastic Material 1**.

Damping 2

- 1 In the **Physics** toolbar, click  **Attributes** and choose **Damping**.
- 2 In the **Settings** window for **Damping**, locate the **Boundary Selection** section.
- 3 From the **Selection** list, choose **Cloth**.
- 4 Locate the **Damping Settings** section. In the β_{dK} text field, type $0.14/\omega_{loss}$.

Linear Elastic Material 1

In the **Model Builder** window, click **Linear Elastic Material 1**.

Damping 3

- 1 In the **Physics** toolbar, click  **Attributes** and choose **Damping**.
- 2 In the **Settings** window for **Damping**, locate the **Boundary Selection** section.
- 3 From the **Selection** list, choose **Foam**.
- 4 Locate the **Damping Settings** section. In the β_{dK} text field, type $0.46/\omega_{loss}$.

Thickness and Offset 1

Change the thickness in the default node to 1 [mm], this will be applied to the Cone of the speaker. Set the thickness of the other speaker parts.

- 1 In the **Model Builder** window, under **Component 1 (comp1) > Shell (shell)** click **Thickness and Offset 1**.
- 2 In the **Settings** window for **Thickness and Offset**, locate the **Thickness and Offset** section.
- 3 In the d_0 text field, type 1 [mm].

Thickness and Offset 2

- 1 In the **Physics** toolbar, click  **Boundaries** and choose **Thickness and Offset**.
- 2 In the **Settings** window for **Thickness and Offset**, locate the **Boundary Selection** section.
- 3 From the **Selection** list, choose **Cloth**.
- 4 Locate the **Thickness and Offset** section. In the d_0 text field, type 0.4 [mm].

Thickness and Offset 3

- 1 In the **Physics** toolbar, click  **Boundaries** and choose **Thickness and Offset**.
- 2 In the **Settings** window for **Thickness and Offset**, locate the **Boundary Selection** section.
- 3 From the **Selection** list, choose **Foam**.
- 4 Locate the **Thickness and Offset** section. In the d_0 text field, type 1.5 [mm].

Thickness and Offset 4

- 1 In the **Physics** toolbar, click  **Boundaries** and choose **Thickness and Offset**.
- 2 In the **Settings** window for **Thickness and Offset**, locate the **Boundary Selection** section.
- 3 From the **Selection** list, choose **Glass Fiber**.
- 4 Locate the **Thickness and Offset** section. In the d_0 text field, type 0.2 [mm].

Thickness and Offset 5

- 1 In the **Physics** toolbar, click  **Boundaries** and choose **Thickness and Offset**.
- 2 In the **Settings** window for **Thickness and Offset**, locate the **Boundary Selection** section.
- 3 From the **Selection** list, choose **Basket**.
- 4 Locate the **Thickness and Offset** section. In the d_0 text field, type 0.8 [mm].

Next, add a symmetry condition for the edges in the xz -plane.

Symmetry 1

- 1 In the **Physics** toolbar, click  **Edges** and choose **Symmetry**.
- 2 In the **Settings** window for **Symmetry**, locate the **Edge Selection** section.

3 From the **Selection** list, choose **Symmetry Edges**.

Update the **Structural Steel** material to add the isotropic structural loss factor of 0.01.

MATERIALS

Structural steel (mat2)

1 In the **Model Builder** window, under **Component 1 (comp1)** > **Materials** click **Structural steel (mat2)**.

2 In the **Settings** window for **Material**, locate the **Material Contents** section.

3 In the table, enter the following settings:

Property	Variable	Value	Unit	Property group
Isotropic structural loss factor	eta_s	0.01	1	Basic

Structural steel 1 (mat3)

1 In the **Model Builder** window, click **Structural steel 1 (mat3)**.

2 In the **Settings** window for **Material**, locate the **Material Contents** section.

3 In the table, enter the following settings:

Property	Variable	Value	Unit	Property group
Isotropic structural loss factor	eta_s	0.01	1	Basic

In the following steps, add the multiphysics couplings between the different physics.

MULTIPHYSICS

Acoustic–Structure Boundary 1 (asb1)

1 In the **Physics** toolbar, click  **Multiphysics Couplings** and choose **Boundary** > **Acoustic–Structure Boundary**.

2 In the **Settings** window for **Acoustic–Structure Boundary**, locate the **Boundary Selection** section.

3 From the **Selection** list, choose **All boundaries**.

Acoustic–Structure Boundary 2 (asb2)

1 In the **Physics** toolbar, click  **Multiphysics Couplings** and choose **Boundary** > **Acoustic–Structure Boundary**.

- 2 In the **Settings** window for **Acoustic–Structure Boundary**, locate the **Boundary Selection** section.
- 3 From the **Selection** list, choose **All boundaries**.
- 4 Locate the **Coupled Interfaces** section. From the **Structure** list, choose **Shell (shell)**.

Acoustic–Structure Boundary 3 (asb3)

- 1 In the **Physics** toolbar, click  **Multiphysics Couplings** and choose **Boundary > Acoustic–Structure Boundary**.
- 2 In the **Settings** window for **Acoustic–Structure Boundary**, locate the **Boundary Selection** section.
- 3 From the **Selection** list, choose **Boundaries out of Symmetry Plane**.
- 4 Locate the **Coupled Interfaces** section. From the **Acoustics** list, choose **Pressure Acoustics, Boundary Elements (pabe)**.

Acoustic–Structure Boundary 4 (asb4)

- 1 In the **Physics** toolbar, click  **Multiphysics Couplings** and choose **Boundary > Acoustic–Structure Boundary**.
- 2 In the **Settings** window for **Acoustic–Structure Boundary**, locate the **Boundary Selection** section.
- 3 From the **Selection** list, choose **Boundaries out of Symmetry Plane**.
- 4 Locate the **Coupled Interfaces** section. From the **Acoustics** list, choose **Pressure Acoustics, Boundary Elements (pabe)**.
- 5 From the **Structure** list, choose **Shell (shell)**.

Acoustic BEM–FEM Boundary 1 (aab1)

- 1 In the **Physics** toolbar, click  **Multiphysics Couplings** and choose **Boundary > Acoustic BEM–FEM Boundary**.
- 2 Select Boundary 277 only.

Solid–Thin Structure Connection 1 (sshc1)

- 1 In the **Physics** toolbar, click  **Multiphysics Couplings** and choose **Global > Solid–Thin Structure Connection**.
- 2 In the **Settings** window for **Solid–Thin Structure Connection**, locate the **Connection Settings** section.
- 3 From the **Connection type** list, choose **Shared boundaries**.

In this model, the mesh is set up manually. Proceed by directly adding the first desired mesh component. The mesh needs to resolve the fine details of the geometry as well as the

waves at all frequencies. It is always recommended to have at least two elements through the thickness of thin structures to accurately capture the bending stiffness.

MESH I

Mapped 1

- 1 In the **Mesh** toolbar, click  **More Generators** and choose **Mapped**.
- 2 In the **Settings** window for **Mapped**, locate the **Boundary Selection** section.
- 3 From the **Selection** list, choose **Mapped Boundaries**.

Distribution 1

- 1 Right-click **Mapped 1** and choose **Distribution**.
- 2 Select Edges 165, 270, 309–312, 314, 340, 346, 348, 462, 479, 481, 485, 489, and 510 only.
- 3 In the **Settings** window for **Distribution**, locate the **Distribution** section.
- 4 In the **Number of elements** text field, type 2.

Distribution 2

- 1 In the **Model Builder** window, right-click **Mapped 1** and choose **Distribution**.
- 2 Select Edges 328, 329, 498, and 499 only.
- 3 In the **Settings** window for **Distribution**, locate the **Distribution** section.
- 4 In the **Number of elements** text field, type 10.

Distribution 3

- 1 Right-click **Mapped 1** and choose **Distribution**.
- 2 Select Edges 219, 220, 222, 224, 270, 504, and 505 only.

Distribution 4

- 1 Right-click **Mapped 1** and choose **Distribution**.
- 2 Select Edges 517 and 519 only.
- 3 In the **Settings** window for **Distribution**, locate the **Distribution** section.
- 4 In the **Number of elements** text field, type 3.

Size

- 1 In the **Model Builder** window, under **Component 1 (comp1) > Mesh 1** click **Size**.
- 2 In the **Settings** window for **Size**, locate the **Element Size** section.
- 3 Click the **Custom** button.

4 Locate the **Element Size Parameters** section. In the **Maximum element size** text field, type $1\text{mm}/4$.

5 In the **Minimum element size** text field, type $2[\text{mm}]$.

This gives you a minimum of four elements per wavelength at the highest frequency, 3550 Hz. In practice, remember that a mesh convergence analysis is always recommended.

The shortest edges of the geometry have length 1 mm, which you will resolve with this setting. You can increase the **Minimum element size** setting to get a coarser mesh in the narrow region. This can trigger a warning as COMSOL checks if the minimum size is larger than a geometric entity. The model will solve when a warning is present. It is up to the user to decide if the warning is relevant for the quality of the simulation results.

Use a swept mesh for some of the domains to reduce the running time of the model.

Swept /

1 In the **Mesh** toolbar, click  **Swept**.

2 In the **Settings** window for **Swept**, locate the **Domain Selection** section.

3 From the **Geometric entity level** list, choose **Domain**.

4 From the **Selection** list, choose **Swept Domains**.

Distribution /

1 Right-click **Swept 1** and choose **Distribution**.

2 Select Domains 1–6, 8, 10, and 30–42 only.

3 In the **Settings** window for **Distribution**, locate the **Distribution** section.

4 In the **Number of elements** text field, type 2.

Free Tetrahedral /

1 In the **Mesh** toolbar, click  **Free Tetrahedral**.

2 In the **Settings** window for **Free Tetrahedral**, click to expand the **Element Quality Optimization** section.

3 From the **Optimization level** list, choose **High**.

This option increases the level of optimization of the meshing operation, which will increase the quality of the mesh while slightly increasing the time required for the meshing operation.

Size /

1 Right-click **Free Tetrahedral 1** and choose **Size**.

2 In the **Settings** window for **Size**, locate the **Geometric Entity Selection** section.

- 3 From the **Geometric entity level** list, choose **Boundary**.
- 4 From the **Selection** list, choose **Composite**.
- 5 Locate the **Element Size** section. Click the **Custom** button.
- 6 Locate the **Element Size Parameters** section.
- 7 Select the **Maximum element size** checkbox. In the associated text field, type 8[mm].
- 8 Click  **Build All**.
The mesh plot should look like this.
- 9 In the **Model Builder** window, click **Mesh 1**.

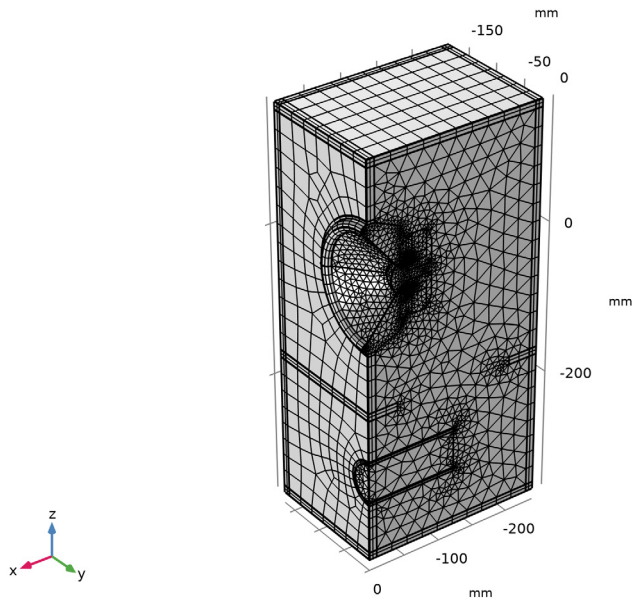

STUDY 1 - COMPLETE STUDY

- 1 In the **Model Builder** window, click **Study 1**.
- 2 In the **Settings** window for **Study**, type Study 1 - Complete Study in the **Label** text field.
- 3 Locate the **Study Settings** section. Clear the **Generate default plots** checkbox.

Step 1: Frequency Domain

- 1 In the **Model Builder** window, under **Study 1 - Complete Study** click **Step 1: Frequency Domain**.
- 2 In the **Settings** window for **Frequency Domain**, locate the **Study Settings** section.

- 3 Click  **Range**.
- 4 In the **Range** dialog, choose **ISO preferred frequencies** from the **Entry method** list.
- 5 In the **Start frequency** text field, type 20.
- 6 In the **Stop frequency** text field, type 3550.
- 7 From the **Interval** list, choose **1/6 octave**.
- 8 Click **Replace**.

This gives you frequencies with a 1/6 octave resolution from 20 to 3550 Hz with values specified by the ISO standard. The model takes about 30 GB of RAM to solve and will solve in around 90 min (depending on your hardware). If you are short on time you can, for example, select 1/3 octave or simply octave spacing.

- 9 Right-click **Study 1 - Complete Study > Step 1: Frequency Domain** and choose **Get Initial Value for Step**.

Getting the initial values of the step creates also the solver suggestions based on the existing physics. Use the direct solver suggestion in this model. In the current setup of the model using a direct solver is faster than the default iterative. Here the BEM problem is small compared to the FEM part. If an iterative solver is used, then note that efficient convergence at the higher frequencies will require the use of the Stabilized BEM formulation.

Solver Configurations

In the **Model Builder** window, expand the **Study 1 - Complete Study > Solver Configurations** node.

Solution 1 (sol1)

- 1 In the **Model Builder** window, expand the **Study 1 - Complete Study > Solver Configurations > Solution 1 (sol1) > Stationary Solver 1** node.
- 2 Right-click **Suggested Direct Solver (aab1_asb4_asb1_sshc1_asb3_asb2)** and choose **Enable**.
- 3 In the **Study** toolbar, click  **Compute**.

Now that the model has been solved, proceed to generate the plots.

RESULTS

In the **Model Builder** window, expand the **Results** node.

Grid 3D 1

- 1 In the **Model Builder** window, expand the **Results > Datasets** node.

- 2 Right-click **Results > Datasets** and choose **More 3D Datasets > Grid 3D**.

This dataset allows for the evaluation of the boundary elements solution at any spatial location in the model.



- 3 In the **Settings** window for **Grid 3D**, locate the **Parameter Bounds** section.
- 4 Find the **First parameter** subsection. In the **Minimum** text field, type -500[mm].
- 5 In the **Maximum** text field, type 500[mm].
- 6 Find the **Second parameter** subsection. In the **Minimum** text field, type -500[mm].
- 7 In the **Maximum** text field, type -0.1[mm].
- 8 Find the **Third parameter** subsection. In the **Minimum** text field, type -400[mm].
- 9 In the **Maximum** text field, type 300[mm].

These coordinates define a box surrounding the speaker where you will plot the variables.

- 10 Click to expand the **Grid** section. In the **x resolution** text field, type 100.
- 11 In the **y resolution** text field, type 100.
- 12 In the **z resolution** text field, type 100.

Increase the resolution from the default values. This produces smoother plots but may increase the time required for evaluating the solution in a plot.



- 13 Click  **Plot**.

- 14 In the **Graphics** window toolbar, click  next to  **Go to Default View**, then choose **Go to View 2**.

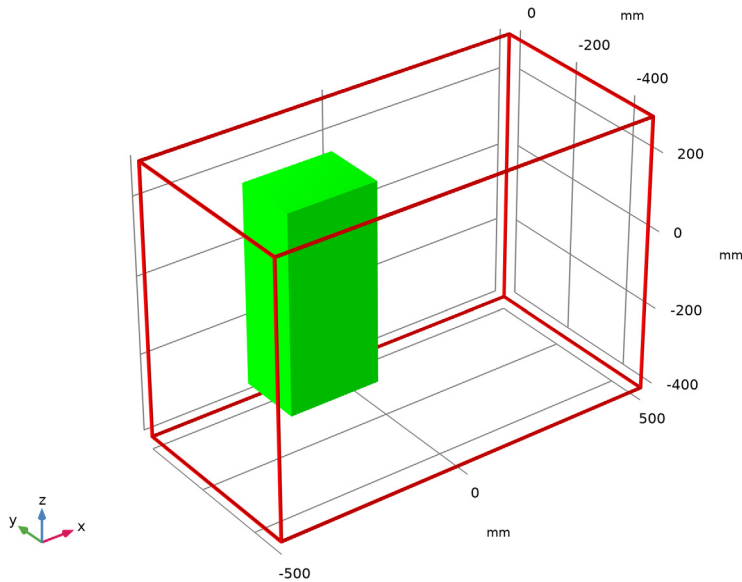
- 15 Click the  **Zoom Extents** button in the **Graphics** toolbar.
The plot should look like this.



RESULT TEMPLATES

- 1 In the **Results** toolbar, click  **Result Templates** to open the **Result Templates** window.
- 2 Go to the **Result Templates** window.
- 3 In the tree, select **Study 1 - Complete Study/Solution 1 (sol1) > Pressure Acoustics, Frequency Domain > Acoustic Pressure (acpr)**.
- 4 Click the **Add Result Template** button in the window toolbar.
- 5 In the **Results** toolbar, click  **Result Templates** to close the **Result Templates** window.

RESULTS

Acoustic Pressure

- 1 In the **Settings** window for **3D Plot Group**, type **Acoustic Pressure** in the **Label** text field.
- 2 Click to expand the **Title** section. From the **Title type** list, choose **Label**.
- 3 Locate the **Plot Settings** section. Clear the **Plot dataset edges** checkbox.

Surface 1

- 1 In the **Model Builder** window, expand the **Acoustic Pressure** node, then click **Surface 1**.
- 2 In the **Settings** window for **Surface**, locate the **Expression** section.
- 3 In the **Expression** text field, type `if(isnan(acpr.p_t),pabe.p_t_bnd,acpr.p_t)`.
This will plot the total acoustic pressure for both Pressure Acoustics interfaces defined in the model.

Deformation 1

- 1 Right-click **Surface 1** and choose **Deformation**.
- 2 In the **Settings** window for **Deformation**, locate the **Expression** section.
- 3 In the **X-component** text field, type `if(isnan(shell.disp),u,u2)`.
- 4 In the **Y-component** text field, type `if(isnan(shell.disp),v,v2)`.
- 5 In the **Z-component** text field, type `if(isnan(shell.disp),w,w2)`.
This is the displacement of the structure obtained from the Shell or the Solid Mechanics interface.

Line 1

- 1 In the **Model Builder** window, right-click **Acoustic Pressure** and choose **Line**.
- 2 In the **Settings** window for **Line**, locate the **Expression** section.
- 3 In the **Expression** text field, type 0.
- 4 Locate the **Coloring and Style** section. From the **Coloring** list, choose **Uniform**.
- 5 From the **Color** list, choose **Black**.
- 6 Click to expand the **Inherit Style** section. From the **Plot** list, choose **Surface 1**.
- 7 Clear the **Color** checkbox.
- 8 Clear the **Color and data range** checkbox.
- 9 Clear the **Tube radius scale factor** checkbox.

Deformation 1



In the **Model Builder** window, under **Results > Acoustic Pressure > Surface 1** right-click **Deformation 1** and choose **Copy**.

Deformation 1

In the **Model Builder** window, right-click **Line 1** and choose **Paste Deformation**.

Multislice 1

- 1 In the **Acoustic Pressure** toolbar, click  **More Plots** and choose **Multislice**.
- 2 In the **Settings** window for **Multislice**, locate the **Data** section.

- 3 From the **Dataset** list, choose **Grid 3D 1**.
- 4 Locate the **Expression** section. In the **Expression** text field, type `pabe.p_t`.
- 5 Locate the **Multiplane Data** section. Find the **x-planes** subsection. From the **Entry method** list, choose **Coordinates**.
- 6 In the **Coordinates** text field, type `-125[mm]`.
- 7 Find the **z-planes** subsection. From the **Entry method** list, choose **Coordinates**.
- 8 In the **Coordinates** text field, type `0`.
- 9 Click to expand the **Inherit Style** section. From the **Plot** list, choose **Surface 1**.
- 10 Click the  **Show Grid** button in the **Graphics** toolbar.
- 11 In the **Acoustic Pressure** toolbar, click  **Plot**.
- 12 Click the  **Zoom Extents** button in the **Graphics** toolbar.
The result should look like [Figure 5](#).

Sound Pressure Level

- 1 In the **Model Builder** window, right-click **Acoustic Pressure** and choose **Duplicate**.
- 2 In the **Model Builder** window, click **Acoustic Pressure 1**.
- 3 In the **Settings** window for **3D Plot Group**, type `Sound Pressure Level1` in the **Label** text field.

Surface 1

- 1 In the **Model Builder** window, click **Surface 1**.
- 2 In the **Settings** window for **Surface**, locate the **Expression** section.
- 3 In the **Expression** text field, type `if(isnan(acpr.Lp), pabe.Lp_bnd, acpr.Lp)`.
- 4 Locate the **Coloring and Style** section. From the **Color table** list, choose **Rainbow**.
- 5 From the **Scale** list, choose **Linear**.
- 6 Click to expand the **Quality** section. From the **Resolution** list, choose **Extra fine**.

Multislice 1

- 1 In the **Model Builder** window, click **Multislice 1**.
- 2 In the **Settings** window for **Multislice**, locate the **Expression** section.
- 3 In the **Expression** text field, type `pabe.Lp`.
- 4 In the **Sound Pressure Level** toolbar, click  **Plot**.

The result should look like [Figure 6](#).

Displacement

- 1 In the **Model Builder** window, right-click **Sound Pressure Level** and choose **Duplicate**.
- 2 In the **Model Builder** window, click **Sound Pressure Level 1**.
- 3 In the **Settings** window for **3D Plot Group**, type Displacement in the **Label** text field.

Surface 1

- 1 In the **Model Builder** window, click **Surface 1**.
- 2 In the **Settings** window for **Surface**, locate the **Expression** section.
- 3 In the **Expression** text field, type `if(isnan(shell.disp),solid.disp,shell.disp)`.

Multislice 1

In the **Model Builder** window, right-click **Multislice 1** and choose **Delete**.

Displacement

- 1 In the **Model Builder** window, under **Results** click **Displacement**.
- 2 In the **Displacement** toolbar, click  **Plot**.
Loop through the frequencies to reproduce the results in [Figure 3](#) and [Figure 10](#).

Stress

- 1 Right-click **Displacement** and choose **Duplicate**.
- 2 In the **Model Builder** window, click **Displacement 1**.
- 3 In the **Settings** window for **3D Plot Group**, type Stress in the **Label** text field.
- 4 Locate the **Data** section. From the **Parameter value (freq (Hz))** list, choose **140**.
In the next steps, a selection is created to show only the stress results at the basket. This selection can be modified or removed completely to analyze other areas of the model.
- 5 Click to expand the **Selection** section. From the **Geometric entity level** list, choose **Boundary**.
- 6 From the **Selection** list, choose **Basket**.
- 7 Select the **Apply to dataset edges** checkbox.

Surface 1

- 1 In the **Model Builder** window, click **Surface 1**.
- 2 In the **Settings** window for **Surface**, locate the **Expression** section.
- 3 In the **Expression** text field, type `if(isnan(shell.mises),solid.mises,shell.mises)`.
- 4 From the **Unit** list, choose **MPa**.

5 In the **Stress** toolbar, click  **Plot**.

The result should look like [Figure 9](#).

Radiation Pattern

1 In the **Model Builder** window, right-click **Sound Pressure Level** and choose **Duplicate**.

2 In the **Model Builder** window, click **Sound Pressure Level 1**.

3 In the **Settings** window for **3D Plot Group**, type Radiation Pattern in the **Label** text field.

Multislice 1

In the **Model Builder** window, right-click **Multislice 1** and choose **Delete**.

Radiation Pattern

In the **Model Builder** window, under **Results** click **Radiation Pattern**.

Radiation Pattern 1

1 In the **Radiation Pattern** toolbar, click  **More Plots** and choose **Radiation Pattern**.

2 In the **Settings** window for **Radiation Pattern**, locate the **Expression** section.

3 In the **Expression** text field, type 1000[mm].

4 Clear the **Use as color expression** checkbox.

5 Locate the **Color** section. In the **Expression** text field, type pabe.Lp.

6 Locate the **Evaluation** section. Find the **Angles** subsection. In the **Number of elevation angles** text field, type 160.

7 In the **Number of azimuth angles** text field, type 320.

8 From the **Restriction** list, choose **Manual**.

9 In the ϕ **range** text field, type -180.

10 Find the **Sphere** subsection. From the **Sphere** list, choose **Manual**.

11 In the **Radius** text field, type 1000[mm].

12 Locate the **Coloring and Style** section. From the **Grid** list, choose **Fine**.

13 In the **Radiation Pattern** toolbar, click  **Plot**.

14 Click the  **Zoom Extents** button in the **Graphics** toolbar.

Surface 1

1 In the **Model Builder** window, click **Surface 1**.

2 In the **Settings** window for **Surface**, locate the **Coloring and Style** section.

3 Clear the **Color legend** checkbox.

- 4 In the **Radiation Pattern** toolbar, click  **Plot**.

Radiation Pattern



- 1 In the **Model Builder** window, click **Radiation Pattern**.
- 2 In the **Settings** window for **3D Plot Group**, locate the **Data** section.
- 3 From the **Parameter value (freq (Hz))** list, choose **20**.
- 4 In the **Radiation Pattern** toolbar, click  **Plot**.

Loop through the frequencies to reproduce the results in [Figure 8](#).

Sensitivity at 1 m.

- 1 In the **Results** toolbar, click  **ID Plot Group**.
- 2 In the **Settings** window for **ID Plot Group**, type *Sensitivity at 1 m.* in the **Label** text field.
- 3 Click to expand the **Title** section. From the **Title type** list, choose **Label**.

Octave Band 1

- 1 In the **Sensitivity at 1 m.** toolbar, click  **More Plots** and choose **Octave Band**.
- 2 In the **Settings** window for **Octave Band**, locate the **Selection** section.
- 3 From the **Geometric entity level** list, choose **Global**.
- 4 Locate the **y-Axis Data** section. In the **Expression** text field, type `at3_spatial(1[m],0,0,pabe.p_t,'minc')`.
- 5 Locate the **Plot** section. From the **Quantity** list, choose **Continuous power spectral density**.
- 6 In the **Sensitivity at 1 m.** toolbar, click  **Plot**.



The result should look like [Figure 11](#).

Directivity xy-plane

- 1 In the **Results** toolbar, click  **ID Plot Group**.
- 2 In the **Settings** window for **ID Plot Group**, type *Directivity xy-plane* in the **Label** text field.
- 3 Locate the **Title** section. From the **Title type** list, choose **Label**.

Directivity 1

- 1 In the **Directivity xy-plane** toolbar, click  **More Plots** and choose **Directivity**.
- 2 In the **Settings** window for **Directivity**, locate the **Expression** section.
- 3 In the **Expression** text field, type `pabe.Lp_t`.

- 4 Locate the **Evaluation** section. Find the **Angles** subsection. In the **Number of angles** text field, type 180.
- 5 From the **Restriction** list, choose **Manual**.
- 6 In the ϕ **start** text field, type -180.
- 7 Find the **Evaluation distance** subsection. In the **Radius** text field, type 1000[mm].
- 8 Locate the **Levels** section. From the **Entry method** list, choose **Levels**.
- 9 In the **Levels** text field, type 9 6 3 1.5 -1.5 -3 -6 -9 -12 -18 -24.
- 10 In the **Directivity xy-plane** toolbar, click  **Plot**.
- 11 Click the  **x-Axis Log Scale** button in the **Graphics** toolbar.
The result should look like [Figure 7](#).

Directivity xz-plane

- 1 In the **Model Builder** window, right-click **Directivity xy-plane** and choose **Duplicate**.
- 2 In the **Model Builder** window, click **Directivity xy-plane 1**.
- 3 In the **Settings** window for **ID Plot Group**, type **Directivity xz-plane** in the **Label** text field.

Directivity I

- 1 In the **Model Builder** window, click **Directivity I**.
- 2 In the **Settings** window for **Directivity**, locate the **Evaluation** section.
- 3 Find the **Normal vector** subsection. In the **y** text field, type -1.
- 4 In the **z** text field, type 0.
- 5 In the **Directivity xz-plane** toolbar, click  **Plot**.

The result should look like [Figure 7](#).

Proceed with creating an export for the loudspeaker radiation data. You can choose to export data as real and imaginary parts of the sound pressure or as sound pressure level and phase.

Radiation Pattern I



- 1 In the **Results** toolbar, click  **Data** and choose **Radiation Pattern**.
- 2 In the **Settings** window for **Radiation Pattern**, locate the **Expressions** section.

3 In the table, enter the following settings:

Expression	Unit	Description
real(pabe.p)	Pa	
imag(pabe.p)	Pa	

- 4 Locate the **Evaluation** section. Find the **Sphere** subsection. From the **Sphere** list, choose **Manual**.
- 5 In the **Radius** text field, type 1000.
- 6 Locate the **Output** section. In the **Filename** text field, type `export_balloon_data.txt`. Click the **Browse** button to select the file location and the **Export** button to save the file.

ADD STUDY

- 1 In the **Home** toolbar, click  **Add Study** to open the **Add Study** window.
- 2 Go to the **Add Study** window.
- 3 Find the **Physics interfaces in study** subsection. In the table, clear the **Solve** checkboxes for **Pressure Acoustics, Frequency Domain (acpr)** and **Pressure Acoustics, Boundary Elements (pabe)**.
- 4 Find the **Multiphysics couplings in study** subsection. In the table, clear the **Solve** checkboxes for **Acoustic–Structure Boundary 1 (asb1)**, **Acoustic–Structure Boundary 2 (asb2)**, **Acoustic–Structure Boundary 3 (asb3)**, **Acoustic–Structure Boundary 4 (asb4)**, and **Acoustic BEM–FEM Boundary 1 (aab1)**.
- 5 Find the **Studies** subsection. In the **Select Study** tree, select **General Studies > Eigenfrequency**.
- 6 Click the **Add Study** button in the window toolbar.
- 7 In the **Home** toolbar, click  **Add Study** to close the **Add Study** window.

STUDY 2

Step 1: Eigenfrequency

- 1 In the **Settings** window for **Eigenfrequency**, locate the **Study Settings** section.
- 2 Select the **Desired number of eigenfrequencies** checkbox. In the associated text field, type 20.
- 3 From the **Search method around shift** list, choose **Larger real part**.
- 4 In the **Model Builder** window, click **Study 2**.
- 5 In the **Settings** window for **Study**, type `Study 2 - Eigenfrequency` in the **Label** text field.

- 6 Locate the **Study Settings** section. Clear the **Generate default plots** checkbox.
- 7 In the **Study** toolbar, click  **Compute**.

RESULTS

Mode Shape

- 1 In the **Model Builder** window, right-click **Displacement** and choose **Duplicate**.
- 2 In the **Settings** window for **3D Plot Group**, type **Mode Shape** in the **Label** text field.
- 3 Locate the **Data** section. From the **Dataset** list, choose **Study 2 - Eigenfrequency/Solution 2 (sol2)**.

Surface 1

- 1 In the **Model Builder** window, expand the **Mode Shape** node, then click **Surface 1**.
- 2 In the **Settings** window for **Surface**, locate the **Coloring and Style** section.
- 3 From the **Color table** list, choose **AuroraBorealis**.
- 4 In the **Mode Shape** toolbar, click  **Plot**.

Loop through the eigenfrequencies to identify the modes that are depicted in the results in [Figure 12](#).

