

# Linear Motor in 2D

## *Introduction*

---

This example shows how to build and analyze a model of a linear motor, a device exerting force in order to produce translational motion. Typical characteristics of linear motors are high precision and quick acceleration. They are used in a wide variety of applications ranging from small actuators to propulsion of transportation systems such as Maglev trains. Here we will consider a flat and slotted topology with a three phase excitation in the stationary part, often called *forcer*. The other part, often called *track*, will be the moving part containing permanent magnets which makes out for a brush-less and synchronous design. A 3D representation of the linear motor is illustrated in [Figure 1](#).

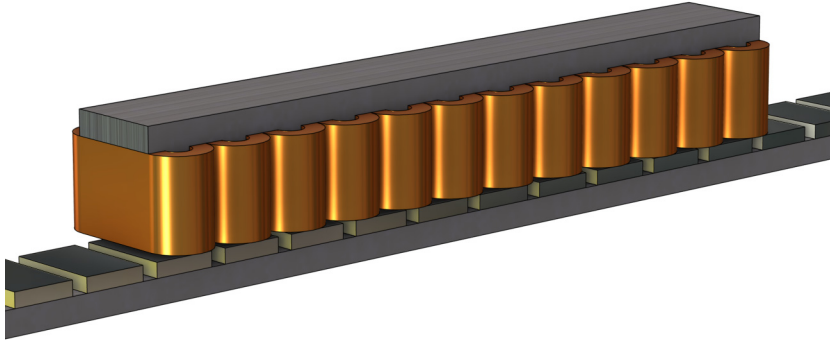

*Figure 1: A 3D representation of the magnetic parts of the linear motor to be simulated.*

A vertical cut along the axis of motion gives a cross section where the currents are perpendicular to the plane and where the major magnetic field gradients vary in-plane, which is in line with 2D magnetic field formulation.

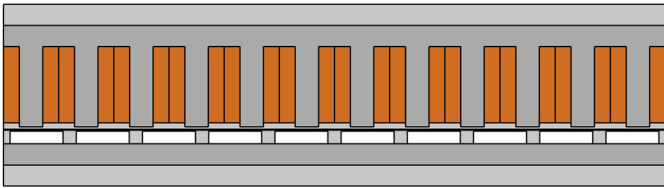

*Figure 2: 2D geometry of linear motor with magnetic steel materials in grey, coils in orange and permanent magnets in white.*

In principle, a cross section of a linear machine is very similar to a 2D representation of an axial flux machine. A circular surface parallel to the axis of rotation (and in line with the magnetic flux direction), will capture the magnetic field gradients in plane and have

perpendicular currents. This linear motor modeling example doubles as a 2D representation of an axial flux machine.

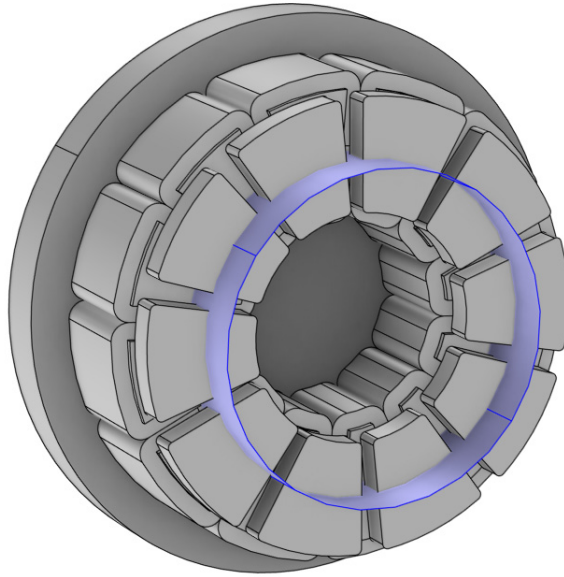

*Figure 3: The blue circular surface rolled out can represent a cross section of an axial flux motor in 2D.*

For the combined model of a linear and an axial flux motor, consider a fractional slot topology. This means that the number of slots divided by the number of phases and the number of poles is less than one, and that coils do not span around more than one tooth. In terms of a linear motor, the geometry represents a periodic section of the machine. In terms of an axial flux motor, the geometry can represent the entire circular cross section.

For simplicity, consider a low but reasonable number of 12 slots and 10 poles on a periodic and symmetric geometry spanning approximately 150 mm in the direction of linear motion. For an axial flux motor, the modeled surface is preferably centered radially in the magnetic region, which in this case represents a surface diameter of roughly 50 mm.

The simulation comprises two studies, where the first one determines the optimal current angle, and the second one simulates linear motion in time. The resulting air-gap shear stress, total force and torque, energy balance, and harmonics are postprocessed and analyzed.

## Modeling in COMSOL Multiphysics

---

In order to properly account for the interaction between the stationary and moving parts, the geometry is split into two objects called an *assembly* in COMSOL Multiphysics. In this example, the split is created along a horizontal line centered in the middle of the air gap. The Moving Mesh interface lets you define the motion of the moving part.

The parts are coupled on their adjacent boundaries in the middle of the air gap by the Periodic Pair feature. The Periodic Pair feature performs a transformation of the field crossing the boundaries accounting for the instantaneous velocity. Where the boundaries are not adjacent to each other, the Periodic Pair maps the field back together assuming symmetric geometry. For the external vertical boundaries on each side, a Periodic Condition feature is applied for both stationary and moving parts.

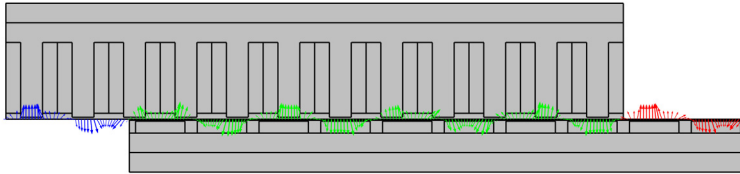

*Figure 4: Arrows showing magnetic flux density and direction on boundary in the middle of the air gap. The field protruding from the moving part (red arrows) is mapped onto the stationary part (blue arrows).*

In the air gap, a thin domain is added in order to accurately compute the linear force produced. An integral of the magnetic force density in the direction of motion over this domain provides a robust way of calculating the shear force acting on the parts.

The optimal current angle is determined by a stationary simulation keeping the moving part at the initial position, while sweeping the current vector over one electrical period. The initial current angle constant is then updated with an angle corresponding to the maximum force. The motion of the moving part is defined such that it moves in synchronization and in the same direction as the winding magnetic field.

In this example, the motion is prescribed as a constant velocity. It is also possible to add equations governing a dynamic motion — a result of forces, friction, and mass of inertia.

### Results and Discussion

Figure 5 shows a plot of the magnetic flux density, giving an impression of the field distribution at a given instant.

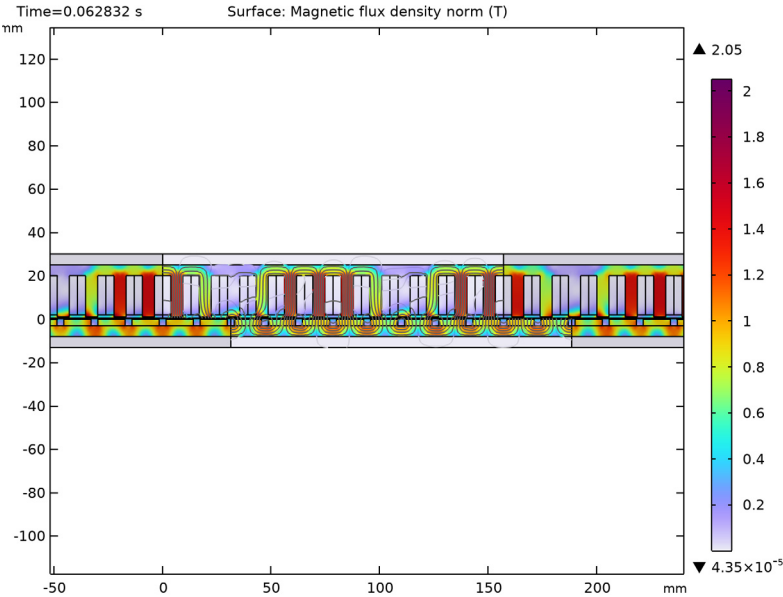

Figure 5: Magnetic flux density distribution at the end of first electrical period (the regions without contour lines on each side are postprocessed displacements of the modeled result).

Figure 6 shows the linear force as a function of time for one electrical period. The linear force is on average 56 N and has the 12th harmonic of electrical frequency as the most prominent peak.

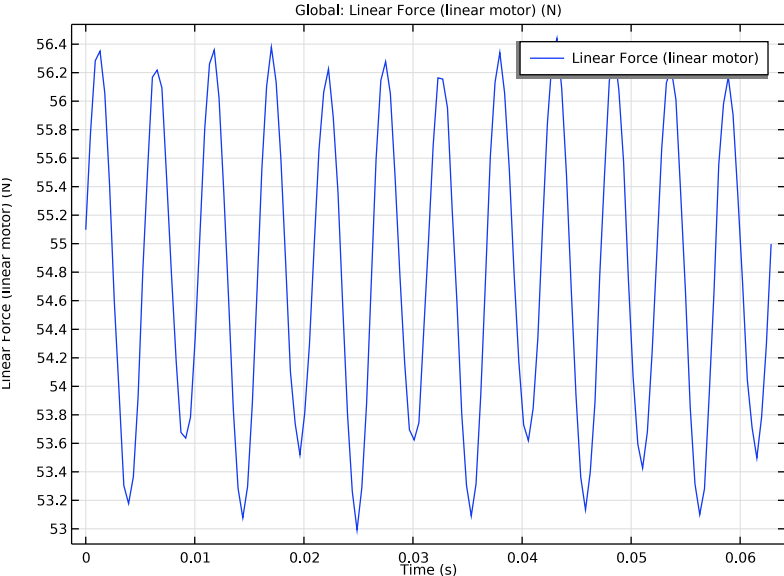
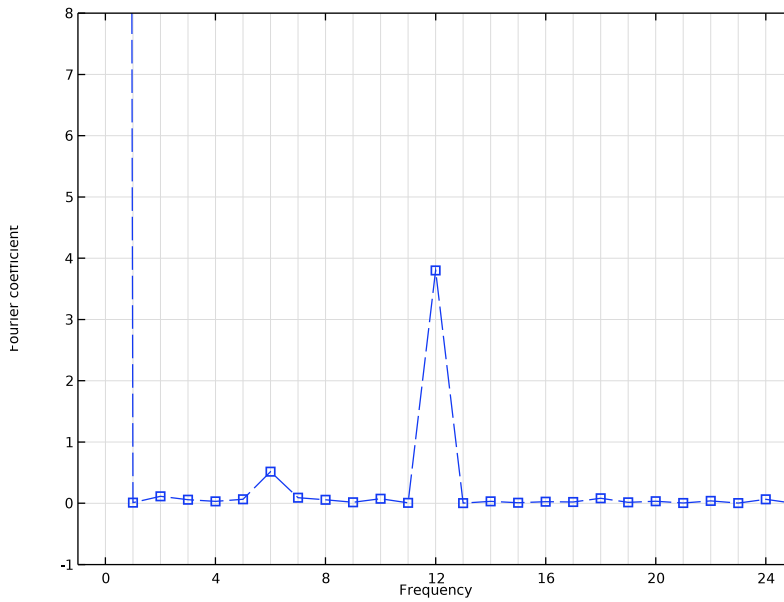

Figure 6: Linear force as function of time for one electrical period.

A Fourier transform of the linear force signal reveals that the 12th harmonic is about eight times larger than the 6th harmonic, as shown in [Figure 7](#).



*Figure 7: Harmonic content of the linear force with the electrical frequency as basis.*

The overall results are evaluated in an **Evaluation Group** which allows for a tabulated presentation of quantities of different units.

TABLE 1: RESULTS SUMMARY.

QUANTITY	VALUE
Airgap shear stress (Pa)	17990
Linear force (N)	56.5
Torque (axial flux motor) (N·m)	1.4
Linear motion power (W)	28.3
Rotational motion power (W)	28.3
Electric input power (W)	38.0
Windings resistive loss (W)	9.7
Magnets induced loss (W)	0.05

---

**Application Library path:** ACDC\_Module/Devices,\_Motors\_and\_Generators/  
linear\_motor\_2d

---

### *Modeling Instructions*



---

From the **File** menu, choose **New**.

#### **NEW**

In the **New** window, click  **Model Wizard**.

#### **MODEL WIZARD**

- 1 In the **Model Wizard** window, click  **2D**.
- 2 In the **Select Physics** tree, select **AC/DC** > **Electromagnetic Fields** > **Magnetic Fields (mf)**.
- 3 Click **Add**.
- 4 Click  **Done**.

#### **GEOMETRY I**

- 1 In the **Model Builder** window, under **Component I (comp1)** click **Geometry I**.
- 2 In the **Settings** window for **Geometry**, locate the **Units** section.
- 3 From the **Length unit** list, choose **mm**.

#### **GLOBAL DEFINITIONS**

##### *Parameters - main*

- 1 In the **Model Builder** window, under **Global Definitions** click **Parameters I**.
- 2 In the **Settings** window for **Parameters**, type **Parameters - main** in the **Label** text field.
- 3 Locate the **Parameters** section. In the table, enter the following settings:

<b>Name</b>	<b>Expression</b>	<b>Value</b>	<b>Description</b>
Np	10	10	Nr of poles on moving part/rotor
Ns	12	12	Nr of stator slots
v_lin	0.5[m/s]	0.5 m/s	Linear motion velocity
I_ph	2.5[A]	2.5 A	Phase current rms

Name	Expression	Value	Description
Nturn	120	120	Nr of turns per coil
r_inc	25[mm]	0.025 m	Incision/ computational plane radius (axial flux motor)
s_rot	$v_{lin}/(2*\pi*r_{inc})$	3.1831 l/s	Rotational speed (axial flux motor)
f_el	$s_{rot}*N_p/2$	15.915 l/s	Electrical frequency
ang_el_init	0[deg]	0 rad	Initial current angle (max force/ torque)
L_mag	20[mm]	0.02 m	Length into plane/ radial extent of magnetic materials
t	0[s]	0 s	Time variable alias

#### Parameters - geometry

- 1 In the **Home** toolbar, click **Pi Parameters** and choose **Add > Parameters**.
- 2 In the **Settings** window for **Parameters**, type Parameters - geometry in the **Label** text field.
- 3 Locate the **Parameters** section. In the table, enter the following settings:

Name	Expression	Value	Description
arc_inc	$r_{inc}*2*\pi$ [rad]	0.15708 m	Incision plane arc length
th_air	5[mm]	0.005 m	Air thickness outside
th_rbyoke	5[mm]	0.005 m	Rotor back-yoke thickness
th_mag	3[mm]	0.003 m	Magnet thickness
th_airgap	1[mm]	0.001 m	Airgap thickness
th_stooth	19[mm]	0.019 m	Stator toooth thickness
th_coil	18[mm]	0.018 m	Coil thickness
th_sbyoke	5[mm]	0.005 m	Stator back-yoke thickness
ang_mag	$2*\pi$ [rad]/ $N_p*0.8$	0.50265 rad	Magnet pitch angle

Name	Expression	Value	Description
arc_mag	$r\_inc * ang\_mag$	0.012566 m	Magnet arc length
arc_pp	$arc\_inc / N_p$	0.015708 m	Pole pitch arc length
w_slot	7.5[mm]	0.0075 m	Slot width
ang_slot	$2 * asin(w\_slot / 2 / r\_inc)$	0.30114 rad	Slot pitch angle
arc_slot	$r\_inc * ang\_slot$	0.0075284 m	Slot arc length
arc_stooth	$arc\_inc / N_s - arc\_slot$	0.0055616 m	Stator tooth arc length
A_wire	$th\_coil * w\_slot / 2 / N_{turn} * 0.55$	3.0938E-7 m <sup>2</sup>	Wire cross-sectional area including slot fill factor of .55

#### Variables I

- 1 In the **Model Builder** window, right-click **Global Definitions** and choose **Variables**.
- 2 In the **Settings** window for **Variables**, locate the **Variables** section.
- 3 In the table, enter the following settings:

Name	Expression	Unit	Description
iA	$I\_ph * cos(2 * pi * f\_el * t + ang\_el\_init)$	A	A phase current
iB	$I\_ph * cos(2 * pi * f\_el * t + ang\_el\_init - 2 * pi / 3)$	A	B phase current
iC	$I\_ph * cos(2 * pi * f\_el * t + ang\_el\_init - 4 * pi / 3)$	A	C phase current

The geometry construction is colored by it being a representation of a 3D axial flux motor. This means that the width and height of a rectangle is treated as 'arc length' and 'thickness', respectively.

#### GEOMETRY I

##### Rectangle I (r1)

- 1 In the **Geometry** toolbar, click  **Rectangle**.
- 2 In the **Settings** window for **Rectangle**, locate the **Size and Shape** section.
- 3 In the **Width** text field, type arc\_mag.
- 4 In the **Height** text field, type th\_mag.
- 5 Locate the **Position** section. In the **x** text field, type (arc\_pp - arc\_mag) / 2.

6 In the **y** text field, type `-th_mag`.

#### *Move l (movl)*

1 In the **Geometry** toolbar, click  **Transforms** and choose **Move**.

2 Select the object **r1** only.

3 In the **Settings** window for **Move**, locate the **Displacement** section.

4 In the **x** text field, type `arc_pp`.

5 Locate the **Input** section. Select the **Keep input objects** checkbox.

#### *Magnets up*

1 In the **Geometry** toolbar, click  **Transforms** and choose **Array**.

2 In the **Settings** window for **Array**, type **Magnets up** in the **Label** text field.

3 Select the object **r1** only.

4 Locate the **Size** section. In the **x size** text field, type `Np/2`.

5 Locate the **Displacement** section. In the **x** text field, type `arc_pp*2`.

6 Locate the **Selections of Resulting Entities** section. Select the **Resulting objects selection** checkbox.

7 From the **Show in physics** list, choose **Off**.

#### *Magnets down*

1 In the **Geometry** toolbar, click  **Transforms** and choose **Array**.

2 In the **Settings** window for **Array**, type **Magnets down** in the **Label** text field.

3 Select the object **movl** only.

4 Locate the **Size** section. In the **x size** text field, type `Np/2`.

5 Locate the **Displacement** section. In the **x** text field, type `arc_pp*2`.

6 Locate the **Selections of Resulting Entities** section. Select the **Resulting objects selection** checkbox.

7 From the **Show in physics** list, choose **Off**.

#### *All magnets*

1 In the **Geometry** toolbar, click  **Selections** and choose **Union Selection**.

2 In the **Settings** window for **Union Selection**, type **All magnets** in the **Label** text field.

3 Locate the **Input Entities** section. Click  **Add**.

4 In the **Add** dialog, in the **Selections to add** list, choose **Magnets up** and **Magnets down**.

5 Click **OK**.

#### *Rotor back yoke*

- 1 In the **Geometry** toolbar, click  **Rectangle**.
- 2 In the **Settings** window for **Rectangle**, type Rotor back yoke in the **Label** text field.
- 3 Locate the **Size and Shape** section. In the **Width** text field, type arc\_inc.
- 4 In the **Height** text field, type th\_rbyoke.
- 5 Locate the **Position** section. In the **y** text field, type -th\_rbyoke-th\_mag.
- 6 Locate the **Selections of Resulting Entities** section. Select the **Resulting objects selection** checkbox.



#### *Rotor air*

- 1 In the **Geometry** toolbar, click  **Rectangle**.
- 2 In the **Settings** window for **Rectangle**, type Rotor air in the **Label** text field.
- 3 Locate the **Size and Shape** section. In the **Width** text field, type arc\_inc.
- 4 In the **Height** text field, type th\_mag+th\_rbyoke+th\_air+th\_airgap/2.
- 5 Locate the **Position** section. In the **y** text field, type -th\_mag-th\_rbyoke-th\_air.
- 6 Locate the **Selections of Resulting Entities** section. Select the **Resulting objects selection** checkbox.

#### *Aux torque calc domain*

- 1 In the **Geometry** toolbar, click  **Rectangle**.
- 2 In the **Settings** window for **Rectangle**, type Aux torque calc domain in the **Label** text field.
- 3 Locate the **Size and Shape** section. In the **Width** text field, type arc\_inc.
- 4 In the **Height** text field, type th\_airgap/4.
- 5 Locate the **Position** section. In the **y** text field, type th\_airgap/4.
- 6 Locate the **Selections of Resulting Entities** section. Select the **Resulting objects selection** checkbox.

#### *Rotor selection*

- 1 In the **Geometry** toolbar, click  **Selections** and choose **Union Selection**.
- 2 In the **Settings** window for **Union Selection**, type Rotor selection in the **Label** text field.
- 3 Locate the **Geometric Entity Level** section. From the **Level** list, choose **Object**.
- 4 Locate the **Input Entities** section. Click  **Add**.

5 In the **Add** dialog, in the **Selections to add** list, choose **Magnets up**, **Magnets down**, **Rotor back yoke**, **Rotor air**, and **Aux torque calc domain**.

6 Click **OK**.

#### *Rotor*

1 In the **Geometry** toolbar, click  **Booleans and Partitions** and choose **Union**.

2 In the **Settings** window for **Union**, type Rotor in the **Label** text field.

3 Locate the **Union** section. From the **Input objects** list, choose **Rotor selection**.

4 Click the  **Zoom Extents** button in the **Graphics** toolbar.

#### *Stator tooth*

1 In the **Geometry** toolbar, click  **Rectangle**.

2 In the **Settings** window for **Rectangle**, type Stator tooth in the **Label** text field.

3 Locate the **Size and Shape** section. In the **Width** text field, type arc\_stooth.

4 In the **Height** text field, type th\_stooth.

5 Locate the **Position** section. In the **x** text field, type arc\_slot/2.

6 In the **y** text field, type th\_airgap.

7 Click  **Build Selected**.

#### *Stator teeth*

1 In the **Geometry** toolbar, click  **Transforms** and choose **Array**.

2 In the **Settings** window for **Array**, type Stator teeth in the **Label** text field.

3 Select the object **r5** only.

4 Locate the **Size** section. In the **x size** text field, type Ns.

5 Locate the **Displacement** section. In the **x** text field, type arc\_stooth+arc\_slot.

6 Locate the **Selections of Resulting Entities** section. Select the **Resulting objects selection** checkbox.

7 From the **Show in physics** list, choose **Off**.

#### *Stator back yoke*

1 In the **Geometry** toolbar, click  **Rectangle**.

2 In the **Settings** window for **Rectangle**, type Stator back yoke in the **Label** text field.

3 Locate the **Size and Shape** section. In the **Width** text field, type arc\_inc.



4 In the **Height** text field, type th\_sbyoke.

5 Locate the **Position** section. In the **y** text field, type th\_airgap+th\_stooth.

6 Locate the **Selections of Resulting Entities** section. Select the **Resulting objects selection** checkbox.

7 From the **Show in physics** list, choose **Off**.

#### *Stator yoke selection*

- 1 In the **Geometry** toolbar, click  **Selections** and choose **Union Selection**.
- 2 In the **Settings** window for **Union Selection**, type Stator yoke selection in the **Label** text field.
- 3 Locate the **Geometric Entity Level** section. From the **Level** list, choose **Object**.
- 4 Locate the **Input Entities** section. Click  **Add**.
- 5 In the **Add** dialog, in the **Selections to add** list, choose **Stator teeth** and **Stator back yoke**.
- 6 Click **OK**.

#### *Stator yoke*

- 1 In the **Geometry** toolbar, click  **Booleans and Partitions** and choose **Union**.
- 2 In the **Settings** window for **Union**, type Stator yoke in the **Label** text field.
- 3 Locate the **Union** section. From the **Input objects** list, choose **Stator yoke selection**.
- 4 Clear the **Keep interior boundaries** checkbox.

#### *Coil leg*

- 1 In the **Geometry** toolbar, click  **Rectangle**.
- 2 In the **Settings** window for **Rectangle**, type Coil leg in the **Label** text field.
- 3 Locate the **Size and Shape** section. In the **Width** text field, type  $\text{arc\_slot}/2$ .
- 4 In the **Height** text field, type  $\text{th\_coil}$ .
- 5 Locate the **Position** section. In the **y** text field, type  $\text{th\_airgap}+\text{th\_stooth}-\text{th\_coil}$ .



#### *Coil legs left*

- 1 In the **Geometry** toolbar, click  **Transforms** and choose **Array**.
- 2 In the **Settings** window for **Array**, type Coil legs left in the **Label** text field.
- 3 Select the object **r7** only.
- 4 Locate the **Size** section. In the **x size** text field, type  $N_s$ .
- 5 Locate the **Displacement** section. In the **x** text field, type  $\text{arc\_stooth}+\text{arc\_slot}$ .
- 6 Locate the **Selections of Resulting Entities** section. Select the **Resulting objects selection** checkbox.
- 7 From the **Show in physics** list, choose **Off**.

### *Coil legs right*

- 1 In the **Geometry** toolbar, click  **Transforms** and choose **Move**.
- 2 In the **Settings** window for **Move**, type Coil legs right in the **Label** text field.
- 3 Locate the **Input** section. From the **Input objects** list, choose **Coil legs left**.
- 4 Select the **Keep input objects** checkbox.
- 5 Locate the **Displacement** section. In the **x** text field, type  $\text{arc\_slot}/2+\text{arc\_stooth}$ .
- 6 Locate the **Selections of Resulting Entities** section. Select the **Resulting objects selection** checkbox.
- 7 From the **Show in physics** list, choose **Off**.

### *Coil domains*

- 1 In the **Geometry** toolbar, click  **Selections** and choose **Union Selection**.
- 2 In the **Settings** window for **Union Selection**, type Coil domains in the **Label** text field.
- 3 Locate the **Geometric Entity Level** section. From the **Level** list, choose **Object**.
- 4 Locate the **Input Entities** section. Click  **Add**.
- 5 In the **Add** dialog, in the **Selections to add** list, choose **Coil legs left** and **Coil legs right**.
- 6 Click **OK**.
- 7 In the **Settings** window for **Union Selection**, locate the **Resulting Selection** section.
- 8 From the **Show in physics** list, choose **Domain selection**.

### *Stator air*

- 1 In the **Geometry** toolbar, click  **Rectangle**.
- 2 In the **Settings** window for **Rectangle**, type Stator air in the **Label** text field.
- 3 Locate the **Size and Shape** section. In the **Width** text field, type  $\text{arc\_inc}$ .
- 4 In the **Height** text field, type  $\text{th\_airgap}/2+\text{th\_stooth}+\text{th\_sbyoke}+\text{th\_air}$ .
- 5 Locate the **Position** section. In the **y** text field, type  $\text{th\_airgap}/2$ .
- 6 Locate the **Selections of Resulting Entities** section. Select the **Resulting objects selection** checkbox.
- 7 From the **Show in physics** list, choose **Off**.

### *Stator selection*

- 1 In the **Geometry** toolbar, click  **Selections** and choose **Union Selection**.
- 2 In the **Settings** window for **Union Selection**, type Stator selection in the **Label** text field.
- 3 Locate the **Geometric Entity Level** section. From the **Level** list, choose **Object**.

- 4 Locate the **Input Entities** section. Click  **Add**.
- 5 In the **Add** dialog, in the **Selections to add** list, choose **Stator yoke selection**, **Coil legs left**, **Coil legs right**, and **Stator air**.
- 6 Click **OK**.

#### *Stator*

- 1 In the **Geometry** toolbar, click  **Booleans and Partitions** and choose **Union**.
- 2 In the **Settings** window for **Union**, type Stator in the **Label** text field.
- 3 Locate the **Union** section. From the **Input objects** list, choose **Stator selection**.

#### *Form Union (fin)*



- 1 In the **Model Builder** window, under **Component 1 (comp1) > Geometry 1** click **Form Union (fin)**.
- 2 In the **Settings** window for **Form Union/Assembly**, locate the **Form Union/Assembly** section.
- 3 From the **Action** list, choose **Form an assembly**.
- 4 In the **Geometry** toolbar, click  **Build All**.

### **GEOMETRY 1**

In the **Model Builder** window, collapse the **Component 1 (comp1) > Geometry 1** node.

### **DEFINITIONS**

#### *Magnetic Steel domains*

- 1 In the **Definitions** toolbar, click  **Union**.
- 2 In the **Settings** window for **Union**, type Magnetic Steel domains in the **Label** text field.
- 3 Locate the **Input Entities** section. Under **Selections to add**, click  **Add**.
- 4 In the **Add** dialog, in the **Selections to add** list, choose **Rotor back yoke** and **Stator yoke selection**.
- 5 Click **OK**.

#### *Airgap integration*

- 1 In the **Definitions** toolbar, click  **Nonlocal Couplings** and choose **Integration**.  
Next, create an integration operating on the thin domain of the air gap, which will assist in accurate force and torque calculations.
- 2 In the **Settings** window for **Integration**, type Airgap integration in the **Label** text field.
- 3 Locate the **Source Selection** section. From the **Selection** list, choose **Aux torque calc domain**.

## Variables 2

- 1 In the **Model Builder** window, right-click **Definitions** and choose **Variables**.
- 2 In the **Settings** window for **Variables**, locate the **Variables** section.
- 3 In the table, enter the following settings:

Name	Expression	Unit	Description
F_phi	$mf.Bx*mf.By/\mu_0_{const}$	Pa	Shear stress density
Torque	$intop1(F\_phi*r\_inc)/(th\_airgap/4)*L\_mag$	J	Torque (axial flux motor)
Force	$intop1(F\_phi)/(th\_airgap/4)*L\_mag$	N	Linear Force (linear motor)



### Torque

- 1 In the **Definitions** toolbar, click  **Probes** and choose **Global Variable Probe**.

Two probes are added to calculate force and torque while solving.

- 2 In the **Settings** window for **Global Variable Probe**, type Torque in the **Label** text field.
- 3 Locate the **Expression** section. In the **Expression** text field, type Torque.

### Shear Force

- 1 In the **Definitions** toolbar, click  **Probes** and choose **Global Variable Probe**.
- 2 In the **Settings** window for **Global Variable Probe**, type Shear Force in the **Label** text field.
- 3 Locate the **Expression** section. In the **Expression** text field, type Force.
- 4 Click to expand the **Table and Window Settings** section. Click  **Add Plot Window**.

## DEFINITIONS

In the **Model Builder** window, collapse the **Component 1 (comp1) > Definitions** node.

## ADD MATERIAL

- 1 In the **Materials** toolbar, click  **Add Material** to open the **Add Material** window.
- 2 Go to the **Add Material** window.
- 3 In the tree, select **AC/DC > Soft Iron (Without Losses)**.
- 4 Click the **Add to Component** button in the window toolbar.
- 5 In the tree, select **AC/DC > Hard Magnetic Materials > Sintered NdFeB Grades (Chinese Standard) > N40M (Sintered NdFeB)**.
- 6 Click the **Add to Component** button in the window toolbar.
- 7 In the tree, select **AC/DC > Copper**.

- 8 Click the **Add to Component** button in the window toolbar.
- 9 In the **Materials** toolbar, click  **Add Material** to close the **Add Material** window.

## MATERIALS

### *Soft Iron (Without Losses) (mat1)*

- 1 In the **Settings** window for **Material**, locate the **Geometric Entity Selection** section.
- 2 From the **Selection** list, choose **Magnetic Steel domains**.



### *N40M (Sintered NdFeB) (mat2)*

- 1 In the **Model Builder** window, click **N40M (Sintered NdFeB) (mat2)**.
- 2 In the **Settings** window for **Material**, locate the **Geometric Entity Selection** section.
- 3 From the **Selection** list, choose **All magnets**.

### *Copper (mat3)*

- 1 In the **Model Builder** window, click **Copper (mat3)**.
- 2 In the **Settings** window for **Material**, locate the **Geometric Entity Selection** section.
- 3 From the **Selection** list, choose **Coil domains**.

## COMPONENT I (COMP1)

- 1 In the **Model Builder** window, click **Component I (comp1)**.
- 2 In the **Settings** window for **Component**, in the **Graphics** window toolbar, click  **Colors**, then choose **Show Material Color and Texture**.
- 3 Click the  **Zoom Extents** button in the **Graphics** toolbar.

### *Moving part/ rotor*

- 1 In the **Physics** toolbar, click  **Moving Mesh** and choose **Prescribed Deformation**.
- 2 In the **Settings** window for **Prescribed Deformation**, type *Moving part/ rotor* in the **Label** text field.
- 3 Locate the **Geometric Entity Selection** section. From the **Selection** list, choose **Rotor selection**.
- 4 Locate the **Prescribed Deformation** section. Specify the  $dx$  vector as



$v\_lin*t$	X
0	Y

## MAGNETIC FIELDS (MF)

- 1 In the **Model Builder** window, under **Component I (comp1)** click **Magnetic Fields (mf)**.

- 2 In the **Settings** window for **Magnetic Fields**, locate the **Thickness** section.
- 3 In the  $d$  text field, type L\_mag.  
In this model, the **Out-of-plane thickness** setting will affect the resistance and voltage in coil features.
- 4 Click to expand the **Discretization** section. From the **Magnetic vector potential** list, choose **Linear**.



#### *Periodic Pair 1*

- 1 In the **Physics** toolbar, click  **Pairs** and choose **Periodic Pair**.  
Next, add the **Periodic Pair** feature and configure it to operate on the **Identity Boundary Pair** which was created in the final step in geometry sequence.
- 2 In the **Settings** window for **Periodic Pair**, locate the **Pair Selection** section.
- 3 Click  **Add**.
- 4 In the **Add** dialog, select **Identity Boundary Pair 1 (ap1)** in the **Pairs** list.
- 5 Click **OK**.

#### *Periodic Condition - stator*

- 1 In the **Physics** toolbar, click  **Boundaries** and choose **Periodic Condition**.
- 2 In the **Settings** window for **Periodic Condition**, type Periodic Condition - stator in the **Label** text field.
- 3 Select Boundaries 64, 66, 68, 70, and 190–193 only.

#### *Periodic Condition - moving part/ rotor*

- 1 In the **Physics** toolbar, click  **Boundaries** and choose **Periodic Condition**.
- 2 In the **Settings** window for **Periodic Condition**, type Periodic Condition - moving part/ rotor in the **Label** text field.
- 3 Select Boundaries 1, 3, 5, 7, and 60–63 only.
- 4 Click the  **Zoom Extents** button in the **Graphics** toolbar.

#### *Magnetic steel*

- 1 In the **Physics** toolbar, click  **Domains** and choose **Laminated Core**.
- 2 In the **Settings** window for **Laminated Core**, type Magnetic steel in the **Label** text field.
- 3 Locate the **Domain Selection** section. From the **Selection** list, choose **Magnetic Steel domains**.
- 4 Locate the **Lamination Model** section. From the **Lamination model** list, choose **Out-of-plane lamination**.

5 In the  $s$  text field, type 1.

#### *A phase winding*

- 1 In the **Physics** toolbar, click  **Domains** and choose **Coil**.
- 2 In the **Settings** window for **Coil**, type A phase winding in the **Label** text field.
- 3 Select Domains 16, 19, 28–31, 40, and 41 only.
- 4 Locate the **Coil** section. From the **Conductor model** list, choose **Homogenized multiturn**.
- 5 Select the **Coil group** checkbox.
- 6 In the  $I_{\text{coil}}$  text field, type  $iA$ .
- 7 Locate the **Homogenized Conductor** section. In the  $N$  text field, type  $N_{\text{turn}}$ .
- 8 From the list, choose **User defined**.
- 9 Find the **High-frequency effective loss** subsection. Clear the **Include harmonic loss** checkbox.
- 10 In the  $a$  text field, type  $A_{\text{wire}}$ .

#### *Reversed Current Direction I*

- 1 In the **Physics** toolbar, click  **Attributes** and choose **Reversed Current Direction**.
- 2 Select Domains 19, 29, 30, and 40 only.

#### *B phase winding*

- 1 In the **Model Builder** window, right-click **A phase winding** and choose **Duplicate**.
- 2 In the **Settings** window for **Coil**, type B phase winding in the **Label** text field.
- 3 Locate the **Domain Selection** section. Click  **Clear Selection**.
- 4 Select Domains 20–23 and 32–35 only.
- 5 Locate the **Coil** section. In the  $I_{\text{coil}}$  text field, type  $iB$ .

#### *Reversed Current Direction I*

- 1 In the **Model Builder** window, expand the **B phase winding** node, then click **Reversed Current Direction I**.
- 2 In the **Settings** window for **Reversed Current Direction**, locate the **Domain Selection** section.
- 3 Click  **Clear Selection**.
- 4 Select Domains 21, 22, 32, and 35 only.

#### *C phase winding*

- 1 In the **Model Builder** window, right-click **B phase winding** and choose **Duplicate**.

- 2 In the **Settings** window for **Coil**, type C phase winding in the **Label** text field.
- 3 Locate the **Domain Selection** section. Click  **Clear Selection**.
- 4 Select Domains 24–27 and 36–39 only.
- 5 Locate the **Coil** section. In the  $I_{\text{coil}}$  text field, type iC.

#### *Reversed Current Direction I*

- 1 In the **Model Builder** window, expand the **C phase winding** node, then click **Reversed Current Direction I**.
- 2 In the **Settings** window for **Reversed Current Direction**, locate the **Domain Selection** section.
- 3 Click  **Clear Selection**.
- 4 Select Domains 24, 27, 37, and 38 only.

In order to ensure zero net current flowing through magnets, **Magnet** features is added.

#### *Magnet I*

- 1 In the **Physics** toolbar, click  **Domains** and choose **Magnet**.
- 2 In the **Settings** window for **Magnet**, locate the **Domain Selection** section.
- 3 From the **Selection** list, choose **All magnets**.
- 4 Locate the **Magnet** section. From the **Pattern type** list, choose **Linear pattern (or domain index based)**.
- 5 From the **Type of periodicity** list, choose **Alternating**.

#### *North I*

- 1 In the **Model Builder** window, click **North I**.
- 2 Select Boundary 12 only.

#### *South I*

- 1 In the **Model Builder** window, click **South I**.
- 2 Select Boundary 11 only.
- 3 In the **Model Builder** window, collapse the **Magnetic Fields (mf)** node.

The default mesh is slightly refined in order to properly resolve the force harmonics appearing in the air gap.

#### **MESH I**

In the **Model Builder** window, under **Component I (comp1)** right-click **Mesh I** and choose **Edit Physics-Induced Sequence**.

### *Size 1 - periodic boundaries*

- 1 In the **Model Builder** window, right-click **Free Triangular 1** and choose **Size**.
- 2 In the **Settings** window for **Size**, type **Size 1 - periodic boundaries** in the **Label** text field.
- 3 Locate the **Geometric Entity Selection** section. From the **Geometric entity level** list, choose **Boundary**.
- 4 Select Boundaries 3, 5, 7, 64, 66, 68, and 70 only.
- 5 Locate the **Element Size** section. Click the **Custom** button.
- 6 Locate the **Element Size Parameters** section.
- 7 Select the **Maximum element size** checkbox. In the associated text field, type **2[mm]**.

### *Size 2 - magnetic steel*

- 1 Right-click **Free Triangular 1** and choose **Size**.
- 2 In the **Settings** window for **Size**, type **Size 2 - magnetic steel** in the **Label** text field.
- 3 Locate the **Geometric Entity Selection** section. From the **Geometric entity level** list, choose **Domain**.
- 4 From the **Selection** list, choose **Magnetic Steel domains**.
- 5 Locate the **Element Size** section. Click the **Custom** button.
- 6 Locate the **Element Size Parameters** section.
- 7 Select the **Maximum element size** checkbox. In the associated text field, type **2[mm]**.



### *Size 3 - airgap*

- 1 Right-click **Free Triangular 1** and choose **Size**.
- 2 In the **Settings** window for **Size**, type **Size 3 - airgap** in the **Label** text field.
- 3 Locate the **Geometric Entity Selection** section. From the **Geometric entity level** list, choose **Domain**.
- 4 Select Domain 15 only.
- 5 Locate the **Element Size** section. Click the **Custom** button.
- 6 Locate the **Element Size Parameters** section.
- 7 Select the **Maximum element size** checkbox. In the associated text field, type **0.5[mm]**.
- 8 Click  **Build All**.

## **MESH 1**

In the **Model Builder** window, collapse the **Component 1 (comp1) > Mesh 1** node.

## ADD STUDY

- 1 In the **Home** toolbar, click  **Add Study** to open the **Add Study** window.
- 2 Go to the **Add Study** window.
- 3 Find the **Studies** subsection. In the **Select Study** tree, select **General Studies > Stationary**.
- 4 Click the **Add Study** button in the window toolbar.
- 5 In the **Home** toolbar, click  **Add Study** to close the **Add Study** window.

## STUDY 1 - CURRENT ANGLE SWEEP

In the **Settings** window for **Study**, type Study 1 - Current angle sweep in the **Label** text field.

### *Step 1: Stationary*

- 1 In the **Model Builder** window, under **Study 1 - Current angle sweep** click **Step 1: Stationary**.
- 2 In the **Settings** window for **Stationary**, click to expand the **Study Extensions** section.
- 3 Select the **Auxiliary sweep** checkbox.
- 4 Click  **Add**.
- 5 In the table, enter the following settings:

Parameter name	Parameter value list	Parameter unit
ang_el_init (Initial current angle (max force/ torque))	range(0, 10, 360)	deg

## STUDY 1 - CURRENT ANGLE SWEEP

- 1 In the **Model Builder** window, collapse the **Study 1 - Current angle sweep** node.
- 2 In the **Study** toolbar, click  **Compute**.

## RESULTS

### *Probe Plot Group 1*

While solving, click the **Probe Plot 1** tab in the graphics window. Note the value of **ang\_el\_init** giving the maximum force and update the parameter value.

## GLOBAL DEFINITIONS



### *Parameters - main*

- 1 In the **Model Builder** window, under **Global Definitions** click **Parameters - main**.
- 2 In the **Settings** window for **Parameters**, locate the **Parameters** section.

3 In the table, enter the following settings:

Name	Expression	Value	Description
ang_e1_init	90[deg]	1.5708 rad	Initial current angle (max force/ torque)

#### ADD STUDY

- 1 In the **Home** toolbar, click  **Add Study** to open the **Add Study** window.
- 2 Go to the **Add Study** window.
- 3 Find the **Studies** subsection. In the **Select Study** tree, select **General Studies > Stationary**.
- 4 Click the **Add Study** button in the window toolbar.
- 5 In the **Home** toolbar, click  **Add Study** to close the **Add Study** window.

#### STUDY 2 - TRANSIENT

In the **Settings** window for **Study**, type Study 2 - Transient in the **Label** text field.

##### Step 2: Time Dependent

- 1 In the **Study** toolbar, click  **Study Steps** and choose **Time Dependent > Time Dependent**.

For the transient simulation, modify the default solver settings in order to properly resolve the harmonics to be investigated. In the following steps, let the solver know that 144 time steps per electrical period are needed, which corresponds to 12 steps for the 12th harmonic of the electrical frequency.

- 2 In the **Settings** window for **Time Dependent**, locate the **Study Settings** section.
- 3 In the **Output times** text field, type range (0, 1/f\_e1/144, 1/f\_e1).

##### Solution 2 (sol2)

- 1 In the **Study** toolbar, click  **Show Default Solver**.
- 2 In the **Model Builder** window, expand the **Solution 2 (sol2)** node.
- 3 In the **Model Builder** window, expand the **Study 2 - Transient > Solver Configurations > Solution 2 (sol2) > Time-Dependent Solver 1** node, then click **Fully Coupled 1**.
- 4 In the **Settings** window for **Fully Coupled**, click to expand the **Method and Termination** section.
- 5 From the **Jacobian update** list, choose **On every iteration**.

#### STUDY 2 - TRANSIENT

- 1 In the **Model Builder** window, collapse the **Study 2 - Transient** node.

2 In the **Study** toolbar, click  **Compute**.

## RESULTS

### *Magnetic Flux Density (mf) 1*

In the following part, make two duplicates of the surface plot and displace them to each side in order to reproduce the figure of magnetic flux density in the results section.

### *Surface 2*

- 1 In the **Model Builder** window, expand the **Magnetic Flux Density (mf) 1** node.
- 2 Right-click **Results > Magnetic Flux Density (mf) 1 > Surface 1** and choose **Duplicate**.
- 3 In the **Settings** window for **Surface**, click to expand the **Title** section.
- 4 From the **Title type** list, choose **None**.
- 5 Locate the **Coloring and Style** section. From the **Color table** list, choose **PrismDark**.
- 6 Clear the **Color legend** checkbox.

### *Transformation 1*

- 1 Right-click **Surface 2** and choose **Transformation**.
- 2 In the **Settings** window for **Transformation**, locate the **Transformation** section.
- 3 In the **x** text field, type `-arc_inc`.

### *Surface 3*

In the **Model Builder** window, under **Results > Magnetic Flux Density (mf) 1** right-click **Surface 2** and choose **Duplicate**.

### *Transformation 1*

- 1 In the **Model Builder** window, expand the **Surface 3** node, then click **Transformation 1**.
- 2 In the **Settings** window for **Transformation**, locate the **Transformation** section.
- 3 In the **x** text field, type `arc_inc`.
- 4 In the **Magnetic Flux Density (mf) 1** toolbar, click  **Plot**.

### *Magnetic Flux Density (mf) 1*

Next, create an **Evaluation Group**, in order to gather the results.

### *Results summary*

- 1 In the **Results** toolbar, click  **Evaluation Group**.
- 2 In the **Settings** window for **Evaluation Group**, type `Results summary` in the **Label** text field.

3 Locate the **Data** section. From the **Dataset** list, choose **Study 2 - Transient/ Solution 2 (sol2)**.

4 Locate the **Transformation** section. Select the **Transpose** checkbox.

*Surface Average - airgap*

1 Right-click **Results summary** and choose **Average > Surface Average**.

2 In the **Settings** window for **Surface Average**, type Surface Average - airgap in the **Label** text field.

3 Locate the **Selection** section. From the **Selection** list, choose **Aux torque calc domain**.

4 Locate the **Expressions** section. In the table, enter the following settings:

Expression	Unit	Description
F_phi	Pa	Airgap shear stress
F_phi*arc_inc*L_mag	N	Linear force
F_phi*arc_inc*L_mag*r_inc	N*m	Torque (axial flux motor)
F_phi*arc_inc*L_mag*v_lin	W	Linear motion power
F_phi*arc_inc*L_mag*r_inc*s_rot*2*pi[rad]	W	Rotational motion power

5 Locate the **Data Series Operation** section. From the **Transformation** list, choose **Average**.

*Global Evaluation - windings*

1 In the **Model Builder** window, right-click **Results summary** and choose **Global Evaluation**.

2 In the **Settings** window for **Global Evaluation**, type Global Evaluation - windings in the **Label** text field.

Since all coil features differ only by phase offset you can simply multiply the result from a single coil by a factor of three when calculating average values.

3 Locate the **Expressions** section. In the table, enter the following settings:

Expression	Unit	Description
mf.PCoil_1*3	W	Electrical input power
mf.ICoil_1^2*mf.RCoil_1*3	W	Windings resistive loss

4 Locate the **Data Series Operation** section. From the **Transformation** list, choose **Average**.

*Surface Integration - magnets*

1 Right-click **Results summary** and choose **Integration > Surface Integration**.

2 In the **Settings** window for **Surface Integration**, type Surface Integration - magnets in the **Label** text field.

- 3 Locate the **Selection** section. From the **Selection** list, choose **All magnets**.
- 4 Click **Replace Expression** in the upper-right corner of the **Expressions** section. From the menu, choose **Component 1 (comp1) > Magnetic Fields > Heating and losses > mf.Qrh - Volumetric loss density, electric - W/m³**.
- 5 Locate the **Expressions** section. In the table, enter the following settings:

Expression	Unit	Description
mf.Qrh*L_mag	W	Magnets induced loss

- 6 Locate the **Data Series Operation** section. From the **Transformation** list, choose **Average**.
- 7 In the **Results summary** toolbar, click  **Evaluate**.

#### *Linear force*

- 1 In the **Results** toolbar, click  **ID Plot Group**.
- 2 In the **Settings** window for **ID Plot Group**, type **Linear force** in the **Label** text field.
- 3 Locate the **Data** section. From the **Dataset** list, choose **Study 2 - Transient/Solution 2 (sol2)**.

#### *Global I*

- 1 Right-click **Linear force** and choose **Global**.
- 2 In the **Settings** window for **Global**, click **Replace Expression** in the upper-right corner of the **y-Axis Data** section. From the menu, choose **Component 1 (comp1) > Definitions > Variables > Force - Linear Force (linear motor) - N**.
- 3 In the **Linear force** toolbar, click  **Plot**.

#### *Torque harmonics*

- 1 In the **Results** toolbar, click  **ID Plot Group**.
- 2 In the **Settings** window for **ID Plot Group**, type **Torque harmonics** in the **Label** text field.
- 3 Locate the **Data** section. From the **Dataset** list, choose **None**.

#### *Table Graph I*

- 1 Right-click **Torque harmonics** and choose **Table Graph**.  
When performing the Fourier transform, scale the *x*-axis to get the results as harmonics of the electrical frequency.
- 2 In the **Settings** window for **Table Graph**, locate the **Data** section.
- 3 From the **x-axis data** list, choose **Time (s)**.
- 4 From the **Plot columns** list, choose **Manual**.

- 5 In the **Columns** list, select **Torque (axial flux motor) (J)**.
- 6 From the **Transformation** list, choose **Discrete Fourier transform**.
- 7 From the **Show** list, choose **Frequency spectrum**.
- 8 Click to expand the **Preprocessing** section. Find the **x-axis column** subsection. From the **Transformation** list, choose **Linear**.
- 9 In the **Scaling** text field, type  $f_{e1}$ .
- 10 Locate the **Coloring and Style** section. Find the **Line style** subsection. From the **Line** list, choose **Dashed**.
- 11 Find the **Line markers** subsection. From the **Marker** list, choose **Square**.
- 12 In the **Torque harmonics** toolbar, click  **Plot**.

#### *Torque harmonics*

- 1 In the **Model Builder** window, click **Torque harmonics**.
- 2 In the **Settings** window for **ID Plot Group**, locate the **Axis** section.
- 3 Select the **Manual axis limits** checkbox.
- 4 In the **x minimum** text field, type -1.
- 5 In the **x maximum** text field, type 25.
- 6 In the **y minimum** text field, type -1.
- 7 In the **y maximum** text field, type 8.
- 8 Locate the **Grid** section. Select the **Manual spacing** checkbox.
- 9 In the **Torque harmonics** toolbar, click  **Plot**.

