

# Uncertainty Quantification of a Bracket

## Introduction

---

This example demonstrates how to use the Uncertainty Quantification Module by running a series of uncertainty quantification studies for a steel bracket.

This type of bracket can be used to install an actuator that is mounted on a pin placed between the two holes in the bracket arms. The design objective is that the actuator's horizontal misalignment should not be too large.

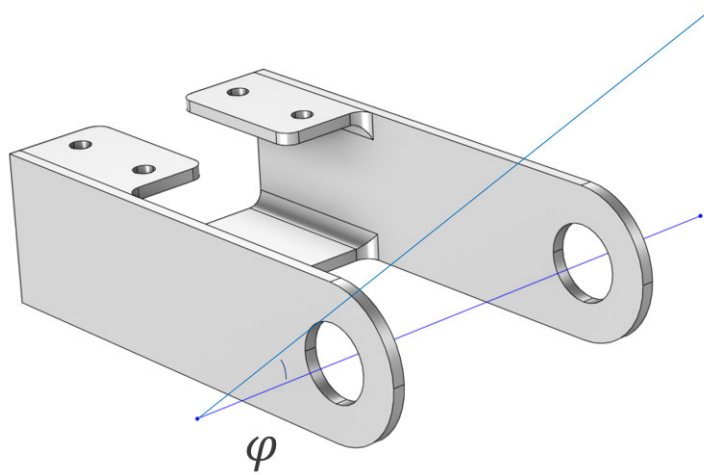

*Figure 1: Bracket geometry with the quantity of interest, the misalignment angle,  $\varphi$ , indicated. The figure shows a different version of the bracket where fillets have been used (requires the Design Module).*

---

**Note:** If you have access to the Design Module, a version using the 3D fillet functionality included with that product is also provided; see [Uncertainty Quantification of a Bracket — Fillet Version](#). A few of the model parameters are slightly changed for the version with fillets but otherwise the instructions are identical.

---

## Model Definition

The geometry is fully parameterized with parameters according to the table shown in Figure 2.

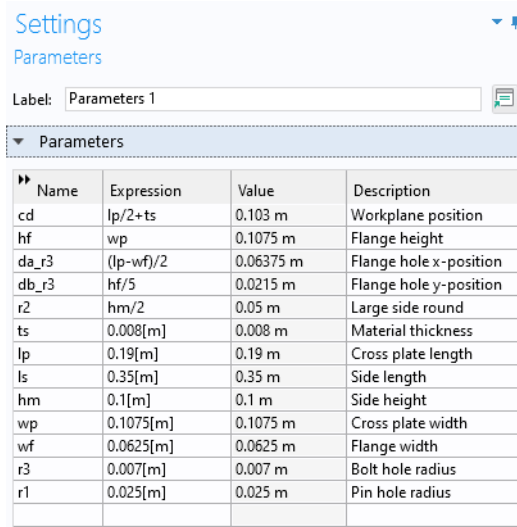

The screenshot shows a 'Settings' window with a 'Parameters' section. Below the section header is a table with four columns: Name, Expression, Value, and Description. The table lists 13 parameters for a bracket model, including dimensions like workplane position, flange height, hole positions, and radii, along with material thickness and plate dimensions.

Name	Expression	Value	Description
cd	$lp/2+ts$	0.103 m	Workplane position
hf	wp	0.1075 m	Flange height
da_r3	$(lp-wf)/2$	0.06375 m	Flange hole x-position
db_r3	$hf/5$	0.0215 m	Flange hole y-position
r2	$hm/2$	0.05 m	Large side round
ts	0.008[m]	0.008 m	Material thickness
lp	0.19[m]	0.19 m	Cross plate length
ls	0.35[m]	0.35 m	Side length
hm	0.1[m]	0.1 m	Side height
wp	0.1075[m]	0.1075 m	Cross plate width
wf	0.0625[m]	0.0625 m	Flange width
r3	0.007[m]	0.007 m	Bolt hole radius
r1	0.025[m]	0.025 m	Pin hole radius

Figure 2: Geometry parameters.

The mesh is customized to have about two elements across the thickness of the material.

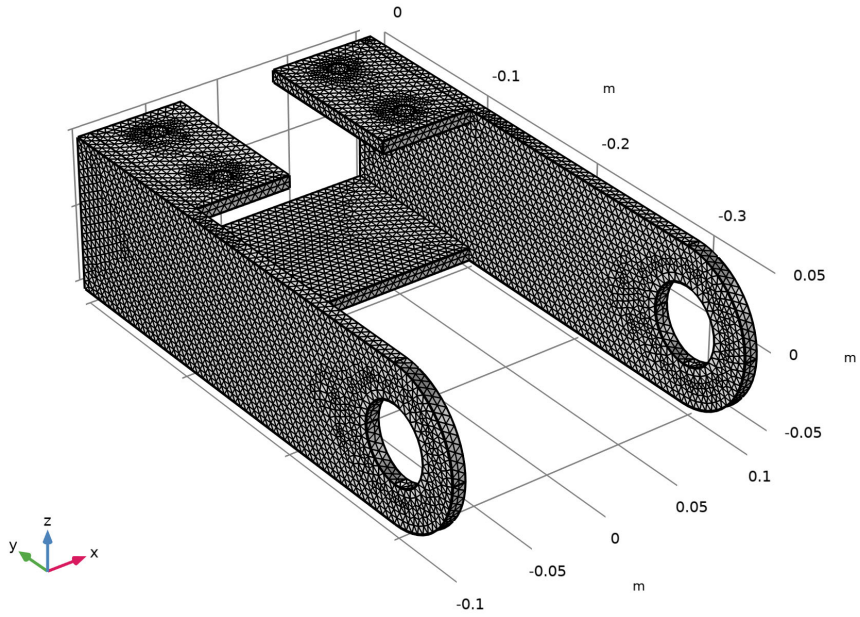

*Figure 3: Meshed geometry.*

In this analysis, the mounting bolts are assumed to be fixed and securely bonded to the bracket. One of the arms is loaded upward and the other downward. The loads are applied

as a pressure on the inner surfaces of the holes, and their intensity is  $P_0 \cos(\alpha)$ , where  $\alpha$  is the angle from the direction of the load resultants.

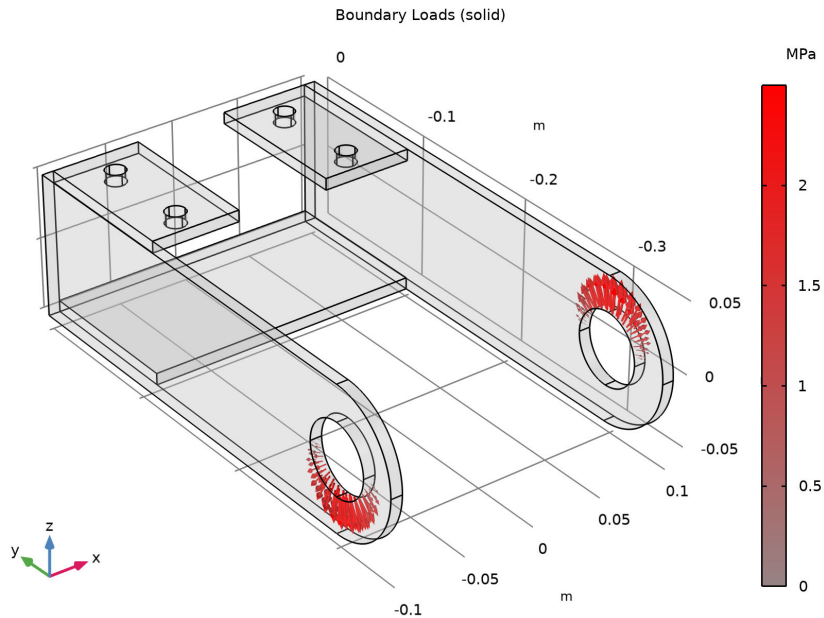

*Figure 4: Applied loads.*

This force is assumed not to vary in the uncertainty quantification studies. Similarly, the material properties for a generic structural steel are assumed not to vary.

The misalignment angle is chosen as the quantity of interest (QoI). The design objective is that the actuator’s horizontal misalignment angle,  $\varphi$ , does not exceed 0.12 degree.<sup>1</sup> The angle is defined as a global variable; for details, see the [Modeling Instructions](#) section.

The parameters to be varied are the geometric dimensions of the bracket.

---

1. The absence of fillets makes the bracket slightly less stiff, so this threshold value needs to be increased by about 20% compared to the value used in the fillet version of the model.

The parameters that participate in the uncertainty quantification are all assumed to be normally distributed around their nominal values according to the table in [Figure 5](#), which corresponds to the screening and sensitivity studies, as described later.

Input parameters table								
Parameter	Distribution	Distribution parameter 1	Distribution parameter 2	CDF-Lower	CDF-Upper	Lower bound	Upper bound	Unit
ts (Material thickness)	Normal( $\mu,\sigma$ )	ts	0.01*ts	Manual	Manual	0.99*ts	1.01*ts	m
lp (Cross plate length)	Normal( $\mu,\sigma$ )	lp	0.01*lp	Manual	Manual	0.95*lp	1.05*lp	m
ls (Side length)	Normal( $\mu,\sigma$ )	ls	0.01*ls	Manual	Manual	0.95*ls	1.05*ls	m
hm (Side height)	Normal( $\mu,\sigma$ )	hm	0.01*hm	Manual	Manual	0.95*hm	1.05*hm	m
wp (Cross plate width)	Normal( $\mu,\sigma$ )	wp	0.01*wp	Manual	Manual	0.95*wp	1.05*wp	m
wf (Flange width)	Normal( $\mu,\sigma$ )	wf	0.01*wf	Manual	Manual	0.95*wf	1.05*wf	m
r1 (Pin hole radius)	Normal( $\mu,\sigma$ )	r1	0.01*r1	Manual	Manual	0.95*r1	1.05*r1	m

Figure 5: Input-parameter distributions used in screening and sensitivity studies.

## THE UNCERTAINTY QUANTIFICATION STUDIES

The Uncertainty Quantification Module provides four different study types:

- Screening, MOAT
  - Identifies the most influential inputs, for each QoI
  - Is based on the Morris One-At-a-Time (MOAT) method
  - Outputs MOAT mean and MOAT standard deviation values
- Sensitivity Analysis
  - Computes the fraction of impact for the inputs, for each QoI
  - Outputs first-order and total Sobol indices
- Uncertainty Propagation
  - Computes the statistical variation of the QoI
  - Outputs a kernel density estimation (KDE) plot representing an estimate of the probability distribution of the QoI
- Reliability Analysis
  - Computes the probability for the fulfillment of a condition based on the QoI
  - For example, what is the probability  $P(\varphi > 0.1)$

For more information, see the *Uncertainty Quantification Module User's Guide*.

## SURROGATE MODELS

To get statistical data based on a physics model you need to run a lot of simulations, varying the parameters of the inputs according to their probability distributions. For a 3D model, this might be computationally unfeasible. To get around this problem, the Uncertainty Quantification Module first builds up a so-called surrogate model that is used

for sensitivity analysis, uncertainty propagation, and reliability analysis (but not for screening).

This process is typically adaptive and the surrogate model can approximate the original model to a high degree of accuracy (which can be modified by the user). The Uncertainty Quantification Module uses two different types of surrogate models:

- Sparse Polynomial Chaos Expansion (SPCE)
  - This surrogate model improves its accuracy by adaptively solving the full model and thereby adding new QoI data by using sequential Latin hypercube sampling.
- Gaussian Process (GP)
  - This surrogate model improves its accuracy by, using information from the current Gaussian Process surrogate model, adaptively solve the full model for new carefully selected sets of parameter values.

### *Results and Discussion*

---

The uncertainty quantification study gives the kernel density estimation plot shown in [Figure 6](#) with associated confidence interval information in the QOI confidence interval table, as shown in [Figure 7](#).

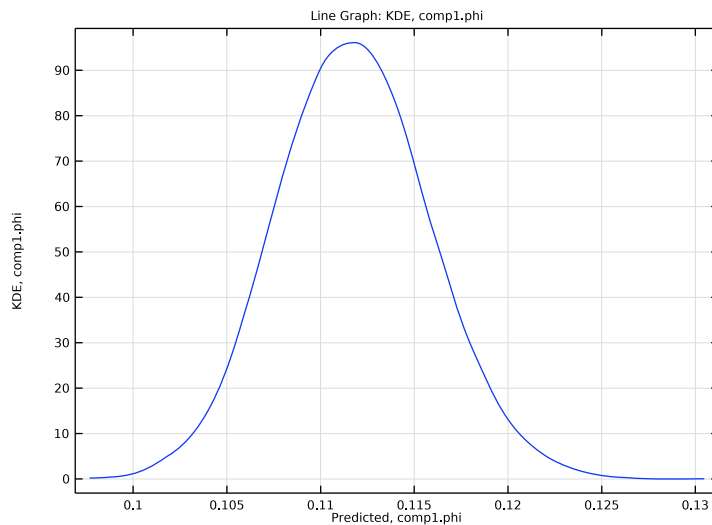

*Figure 6: Kernel density estimation.*

	Mean	STD	Minimum	Maximum	Lower 90%	Upper 90%	Lower 95%	Upper 95%	Lower 99%	Upper 99%
comp1.phi	0.11177	0.0040453	0.097655	0.13045	0.10531	0.11858	0.10404	0.11993	0.10161	0.12266

Figure 7: *QoI confidence interval.*

The reliability analysis study shows that the probability for the misalignment angle  $\phi$  not to exceed 0.12 degree is about 0.022 or 2.2%. This result is made available in the **Probability for conditions** table, as shown in Figure 8.

Probability for conditions
0.021973

Figure 8: *Probability for conditions.*

Note that this value is sensitive to minute changes in the mesh and may vary a bit depending on the COMSOL Multiphysics version you are running.

It is now up to the designer to decide whether this is an acceptable level or risk or if a redesign and/or further studies are needed.

---

**Application Library path:** Uncertainty\_Quantification\_Module/Tutorials/bracket\_uncertainty\_quantification

---

### *Modeling Instructions*

---

From the **File** menu, choose **New**.

#### **NEW**



In the **New** window, click  **Model Wizard**.

#### **MODEL WIZARD**

**1** In the **Model Wizard** window, click  **3D**.

**2** In the **Select Physics** tree, select **Structural Mechanics>Solid Mechanics (solid)**.



- 3 Click **Add**.
- 4 Click  **Study**.
- 5 In the **Select Study** tree, select **General Studies>Stationary**.
- 6 Click  **Done**.

### GEOMETRY I

- 1 In the **Geometry** toolbar, click **Insert Sequence** and choose **Insert Sequence**.
- 2 Browse to the model's Application Libraries folder and double-click the file `bracket_uncertainty_quantification_geom_sequence.mph`.
- 3 In the **Geometry** toolbar, click  **Build All**.

### GLOBAL DEFINITIONS



The geometry sequence already provided a set of geometry dimension parameters. Now define this additional set of parameters for the boundary load and mesh density.

#### Parameters 2

- 1 In the **Home** toolbar, click  **Parameters** and choose **Add>Parameters**.
- 2 In the **Settings** window for **Parameters**, locate the **Parameters** section.
- 3 In the table, enter the following settings:

Name	Expression	Value	Description
P0	2.5[MPa]	2.5E6 Pa	Force per area
dx	lp+ts	0.198 m	X-distance between pin holes
hmax	ts/1.5	0.00533333 m	Max element size
hmin	ts/2.5	0.0032 m	Min element size
YC	-ls+r2	-0.3 m	Y-coordinate of hole center

### ADD MATERIAL

- 1 In the **Home** toolbar, click  **Add Material** to open the **Add Material** window.
- 2 Go to the **Add Material** window.
- 3 In the tree, select **Built-in>Structural steel**.
- 4 Click **Add to Component** in the window toolbar.
- 5 In the **Home** toolbar, click  **Add Material** to close the **Add Material** window.

### DEFINITIONS

Next, define a series of **Explicit** selections to be used for the constraints and loads.

### *Bolt Holes*

- 1 In the **Model Builder** window, expand the **Component 1 (comp1)>Definitions** node.
- 2 Right-click **Definitions** and choose **Selections>Explicit**.
- 3 In the **Settings** window for **Explicit**, locate the **Input Entities** section.
- 4 From the **Geometric entity level** list, choose **Boundary**.
- 5 Select the **Group by continuous tangent** check box. This setting greatly facilitates the selection of curved surfaces. In this case use it to select the four bolt holes. It is sufficient to select one boundary per hole; the three other boundaries will be selected automatically.

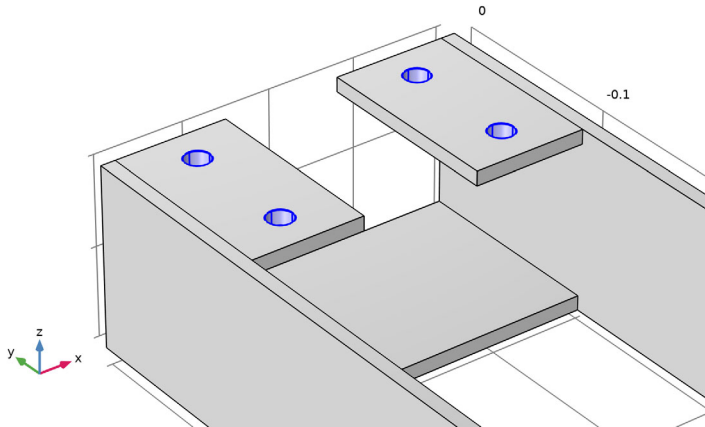

- 6 In the **Label** text field, type Bolt Holes.

### *Left Pin Hole*

- 1 In the **Definitions** toolbar, click  **Explicit**.
- 2 In the **Settings** window for **Explicit**, locate the **Input Entities** section.
- 3 From the **Geometric entity level** list, choose **Boundary**.
- 4 Select the **Group by continuous tangent** check box.

5 Select Boundaries 4, 5, 7, and 8 only.

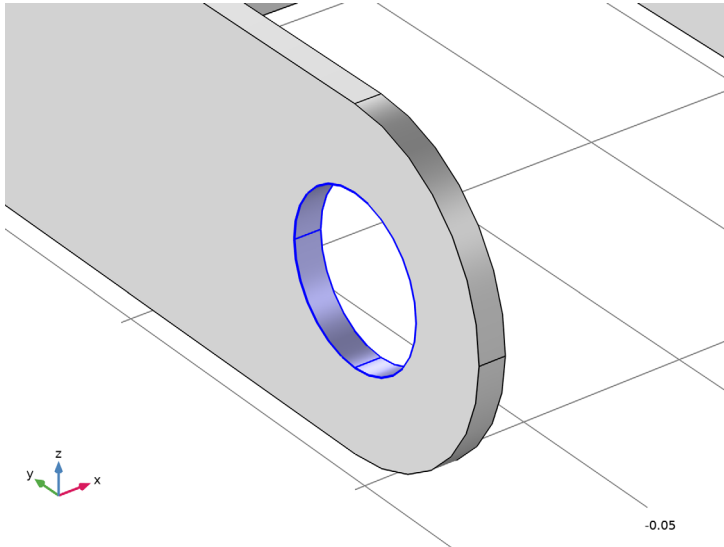

6 In the **Label** text field, type Left Pin Hole.

*Right Pin Hole*

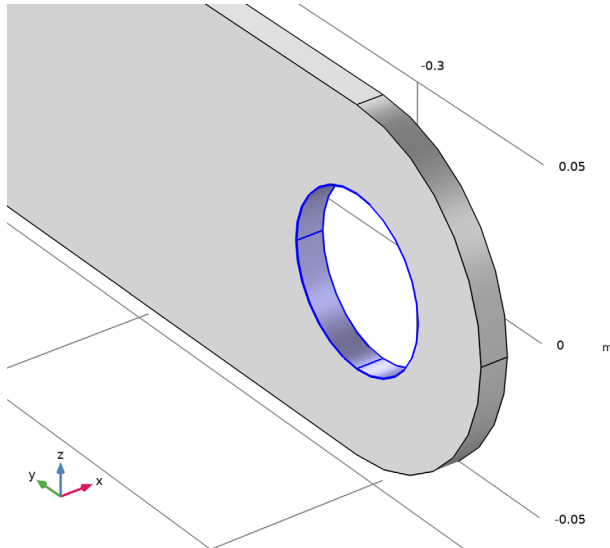

- 1 In the **Definitions** toolbar, click  **Explicit**.
- 2 In the **Settings** window for **Explicit**, locate the **Input Entities** section.
- 3 From the **Geometric entity level** list, choose **Boundary**.
- 4 Select the **Group by continuous tangent** check box.

5 Select Boundaries 45, 46, 48, and 49 only.



6 In the **Label** text field, type Right Pin Hole.

#### *Pin Holes*

- 1 In the **Definitions** toolbar, click  **Union**.
- 2 In the **Settings** window for **Union**, locate the **Geometric Entity Level** section.
- 3 From the **Level** list, choose **Boundary**.
- 4 Locate the **Input Entities** section. Under **Selections to add**, click  **Add**.
- 5 In the **Add** dialog box, in the **Selections to add** list, choose **Left Pin Hole** and **Right Pin Hole**.
- 6 Click **OK**.
- 7 In the **Settings** window for **Union**, type Pin Holes in the **Label** text field.

Define average operators that will be used for computing the average  $z$ -directional displacement of the pin holes.

#### *Average 1 (aveop1)*

- 1 In the **Definitions** toolbar, click  **Nonlocal Couplings** and choose **Average**.
- 2 In the **Settings** window for **Average**, locate the **Source Selection** section.
- 3 From the **Geometric entity level** list, choose **Boundary**.
- 4 From the **Selection** list, choose **Left Pin Hole**.

### Average 2 (aveop2)

- 1 In the **Definitions** toolbar, click  **Nonlocal Couplings** and choose **Average**.
- 2 In the **Settings** window for **Average**, locate the **Source Selection** section.
- 3 From the **Geometric entity level** list, choose **Boundary**.
- 4 From the **Selection** list, choose **Right Pin Hole**.

### Variables 1

- 1 Right-click **Definitions** and choose **Variables**.

Define the quantity of interest (QoI), the misalignment angle, as well as auxiliary variables for the pin hole  $z$ -coordinates.

- 2 In the **Settings** window for **Variables**, locate the **Variables** section.
- 3 In the table, enter the following settings:

Name	Expression	Unit	Description
z1	aveop1(w)	m	Left pin hole center
z2	aveop2(w)	m	Right pin hole center
phi	$\text{atan}((z2-z1)/dx)$ [1/deg]		Misalignment angle

The output from the  $\text{atan}()$  function has the unit radian, which is unitless. The conversion factor [1/deg] corresponds to multiplication by  $180/\pi$  for converting to degrees.

Now, define an analytic function **load** used to apply the spatially varying load on the pin holes.

### Analytic 1 (an1)

- 1 In the **Definitions** toolbar, click  **Analytic**.
- 2 In the **Settings** window for **Analytic**, type **load** in the **Function name** text field.
- 3 Locate the **Definition** section. In the **Expression** text field, type  $F \cdot \cos(\text{atan2}(py, \text{abs}(px)))$ .
- 4 In the **Arguments** text field, type  $F$ ,  $py$ ,  $px$ .
- 5 Locate the **Units** section. In the **Function** text field, type  $\text{Pa}$ .
- 6 In the table, enter the following settings:

Argument	Unit
F	Pa

Argument	Unit
py	m
px	m

### MESH 1

- 1 In the **Model Builder** window, under **Component 1 (comp1)** click **Mesh 1**.
- 2 In the **Settings** window for **Mesh**, locate the **Sequence Type** section.
- 3 From the list, choose **User-controlled mesh**.

Ensure that the mesh density is fine enough to resolve all the stress gradients reasonably well.

#### Size

- 1 In the **Model Builder** window, under **Component 1 (comp1)>Mesh 1** click **Size**.
- 2 In the **Settings** window for **Size**, locate the **Element Size** section.
- 3 Click the **Custom** button.
- 4 Locate the **Element Size Parameters** section. In the **Maximum element size** text field, type hmax.
- 5 In the **Minimum element size** text field, type hmin.
- 6 Click  **Build All**.

### SOLID MECHANICS (SOLID)

Apply fixed constraint boundary conditions on the bolt holes.

#### Fixed Constraint 1

- 1 In the **Model Builder** window, under **Component 1 (comp1)** right-click **Solid Mechanics (solid)** and choose **Fixed Constraint**.
- 2 In the **Settings** window for **Fixed Constraint**, locate the **Boundary Selection** section.
- 3 From the **Selection** list, choose **Bolt Holes**.

Next, apply the spatially varying load.

#### Boundary Load 1

- 1 In the **Physics** toolbar, click  **Boundaries** and choose **Boundary Load**.
- 2 In the **Settings** window for **Boundary Load**, locate the **Coordinate System Selection** section.
- 3 From the **Coordinate system** list, choose **Boundary System 1 (sys1)**.

4 Locate the **Force** section. Specify the  $\mathbf{F}_A$  vector as

0	t1
0	t2
$\text{load}(-P0, Y-YC, Z) * (\text{sign}(X) * Z > 0)$	n

5 Locate the **Boundary Selection** section. From the **Selection** list, choose **Pin Holes**.

### STUDY 1, STATIC

First, run a static analysis with no uncertainty quantification analysis.

- 1 In the **Model Builder** window, click **Study 1**.
- 2 In the **Settings** window for **Study**, type Study 1, Static in the **Label** text field.
- 3 In the **Home** toolbar, click  **Compute**.

### RESULTS

#### *Volume 1*

Now, let us assume that we are only interested in values up to 100 MPa.

- 1 In the **Model Builder** window, expand the **Stress (solid)** node, then click **Volume 1**.
- 2 In the **Settings** window for **Volume**, click to expand the **Range** section.
- 3 Locate the **Expression** section. From the **Unit** list, choose **MPa**.
- 4 In the **Stress (solid)** toolbar, click  **Plot**.
- 5 Locate the **Range** section. Select the **Manual color range** check box.
- 6 In the **Maximum** text field, type 100.

7 In the **Stress (solid)** toolbar, click  **Plot**.

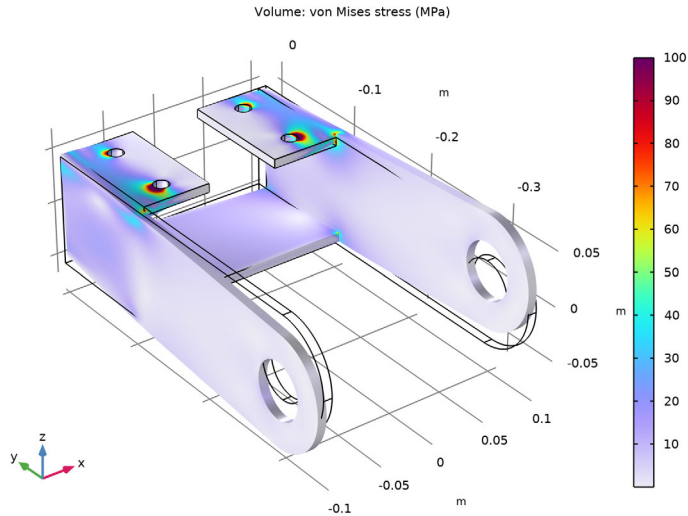

### STUDY 1, STATIC

In the **Model Builder** window, right-click **Study 1, Static** and choose **Uncertainty Quantification>Add Uncertainty Quantification Study Using Study Reference**.

### STUDY 2, SCREENING

In the **Settings** window for **Study**, type **Study 2, Screening** in the **Label** text field.

Next, add a screening analysis to see which input parameters are most significantly impacting the misalignment angle (QoI). The screening study is added as a study reference which means it refers back to the already defined static study.

The parameters that participate in the uncertainty quantification are all assumed to be normally distributed around their nominal values, according to the instructions below. The mean and standard deviation, as well as the max and min limits are all defined in terms of their nominal parameters (from **Global Definitions>Parameters**).

#### *Uncertainty Quantification*

- 1 In the **Model Builder** window, under **Study 2, Screening** click **Uncertainty Quantification**.
- 2 In the **Settings** window for **Uncertainty Quantification**, locate the **Quantities of Interest** section.
- 3 Click **+ Add**.



4 In the table, enter the following settings:

Expression	Description	Individual solution to use
comp1.phi	Misalignment angle	From "Solution to use"

5 Locate the **Input Parameters** section. Click **+** **Add** seven times.

6 In the table, click to select the cell at row number 1 and column number 1.

7 In the table, enter the following settings:

Parameter	Source type	Parameter description
ts (Material thickness)	Analytic	Normal
lp (Cross-plate length)	Analytic	Uniform
ls (Side length)	Analytic	Uniform
hm (Side height)	Analytic	Uniform
wp (Cross-plate width)	Analytic	Uniform
wf (Flange width)	Analytic	Uniform
rl (Pin-hole radius)	Analytic	Uniform

8 From the **Distribution** list, choose **Normal( $\mu,\sigma$ )**.

9 In the **Mean** text field, type ts.

10 In the **Standard deviation** text field, type  $0.01*ts$ .

11 From the **CDF-Lower** list, choose **Manual**.

12 From the **CDF-Upper** list, choose **Manual**.

13 In the **Lower bound** text field, type  $0.99*ts$ .

14 In the **Upper bound** text field, type  $1.01*ts$ .

15 In the **Unit** text field, type m.

16 In the table, click to select the cell at row number 2 and column number 1.

17 From the **Distribution** list, choose **Normal( $\mu,\sigma$ )**.

18 In the **Mean** text field, type lp.

19 In the **Standard deviation** text field, type  $0.01*lp$ .

20 From the **CDF-Lower** list, choose **Manual**.

21 From the **CDF-Upper** list, choose **Manual**.

22 In the **Lower bound** text field, type  $0.95*lp$ .

23 In the **Upper bound** text field, type  $1.05*lp$ .

- 24** In the **Unit** text field, type  $m$ .
- 25** In the table, click to select the cell at row number 3 and column number 1.
- 26** From the **Distribution** list, choose **Normal( $\mu, \sigma$ )**.
- 27** In the **Mean** text field, type  $1s$ .
- 28** In the **Standard deviation** text field, type  $0.01 * 1s$ .
- 29** From the **CDF-Lower** list, choose **Manual**.
- 30** From the **CDF-Upper** list, choose **Manual**.
- 31** In the **Lower bound** text field, type  $0.95 * 1s$ .
- 32** In the **Upper bound** text field, type  $1.05 * 1s$ .
- 33** In the **Unit** text field, type  $m$ .
- 34** In the table, click to select the cell at row number 4 and column number 1.
- 35** From the **Distribution** list, choose **Normal( $\mu, \sigma$ )**.
- 36** In the **Mean** text field, type  $hm$ .
- 37** In the **Standard deviation** text field, type  $0.01 * hm$ .
- 38** From the **CDF-Lower** list, choose **Manual**.
- 39** From the **CDF-Upper** list, choose **Manual**.
- 40** In the **Lower bound** text field, type  $0.95 * hm$ .
- 41** In the **Upper bound** text field, type  $1.05 * hm$ .
- 42** In the **Unit** text field, type  $m$ .
- 43** In the table, click to select the cell at row number 5 and column number 1.
- 44** From the **Distribution** list, choose **Normal( $\mu, \sigma$ )**.
- 45** In the **Mean** text field, type  $wp$ .
- 46** In the **Standard deviation** text field, type  $0.01 * wp$ .
- 47** From the **CDF-Lower** list, choose **Manual**.
- 48** From the **CDF-Upper** list, choose **Manual**.
- 49** In the **Lower bound** text field, type  $0.95 * wp$ .
- 50** In the **Upper bound** text field, type  $1.05 * wp$ .
- 51** In the **Unit** text field, type  $m$ .
- 52** In the table, click to select the cell at row number 6 and column number 1.
- 53** From the **Distribution** list, choose **Normal( $\mu, \sigma$ )**.
- 54** In the **Mean** text field, type  $wf$ .

- 55 In the **Standard deviation** text field, type  $0.01*wf$ .
- 56 From the **CDF-Lower** list, choose **Manual**.
- 57 From the **CDF-Upper** list, choose **Manual**.
- 58 In the **Lower bound** text field, type  $0.95*wf$ .
- 59 In the **Upper bound** text field, type  $1.05*wf$ .
- 60 In the **Unit** text field, type  $m$ .
- 61 In the table, click to select the cell at row number 7 and column number 1.
- 62 From the **Distribution** list, choose **Normal( $\mu,\sigma$ )**.
- 63 In the **Mean** text field, type  $r1$ .
- 64 In the **Standard deviation** text field, type  $0.01*r1$ .
- 65 From the **CDF-Lower** list, choose **Manual**.
- 66 From the **CDF-Upper** list, choose **Manual**.
- 67 In the **Lower bound** text field, type  $0.95*r1$ .
- 68 In the **Upper bound** text field, type  $1.05*r1$ .
- 69 In the **Unit** text field, type  $m$ .
- 70 In the **Home** toolbar, click  **Compute**.

## RESULTS

MOAT, compl.phi

I Click the  **Zoom Extents** button in the **Graphics** toolbar.

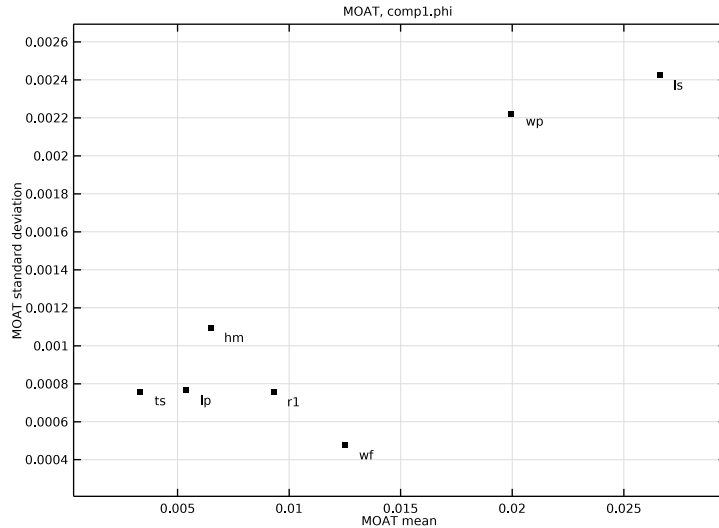

The screening results indicate that the Side length (1s) and the Cross plate width (wp) parameters are the most influential on the quantity of interest. However, several of the other parameters also appear to be significant. A high value of the MOAT mean means that the parameter is significantly influencing the quantity of interest. A high value of the MOAT standard deviation means that the parameter is influential and that it is either interacting with other parameters and/or that it has a nonlinear influence.

## STUDY 2, SCREENING

The next step is a sensitivity analysis. Use the results from the screening to decide which parameters to include in the sensitivity analysis. Sensitivity is more computationally demanding than screening and for this reason we would prefer to pick a subset of the parameters used for the screening study. However, in this example, we would like to learn as much as possible about the model and we pick all the available design parameters. We do not need to type all of the uncertainty quantification parameters again but we can define the new Uncertainty Quantification study for the sensitivity analysis by reusing the information in the screening study.

### Uncertainty Quantification

Right-click **Uncertainty Quantification** and choose

**Add New Uncertainty Quantification Study For>Sensitivity Analysis.**

### STUDY 3, SENSITIVITY

- 1 In the **Model Builder** window, click **Study 3**.
- 2 In the **Settings** window for **Study**, type Study 3, Sensitivity in the **Label** text field.

### Uncertainty Quantification

- 1 In the **Model Builder** window, under **Study 3, Sensitivity** click **Uncertainty Quantification**.
- 2 In the **Settings** window for **Uncertainty Quantification**, locate the **Uncertainty Quantification Settings** section.
- 3 From the **Compute action** list, choose **Compute and analyze**.
- 4 In the **Home** toolbar, click **Compute**.

### RESULTS

*Sobol Index, compl.phi*

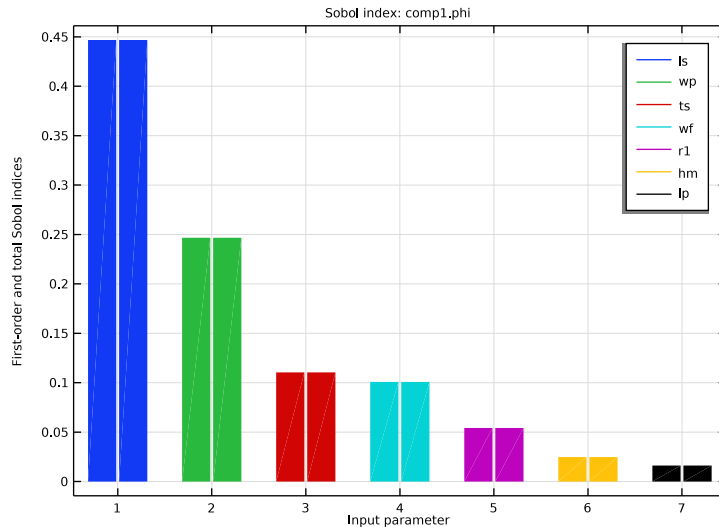

The sensitivity analysis is based on the Sobol method, also known as variance-based sensitivity analysis. The result of the sensitivity analysis a set of Sobol indices and an associated Sobol table and Sobol plot. There are two different types of Sobol indices: first-order index and total index. The first-order index of a parameter shows the sensitivity by

varying this parameter alone. The total index shows how much a parameter contributes to the overall sensitivity.

In this case, the first and total indices are equal, up to the computed accuracy, for all parameters which indicates very little or no interaction between the parameters. The Sobol plot indicates that the misalignment angle is most sensitive to the parameters Side length (1s) and Cross plate width (wp). This is consistent with the screening results.

For the final two studies, Uncertainty Propagation and Reliability Analysis, we will, for the purpose of faster demonstration, delete all parameters except for the dominant two, 1s and wp. However, to get a conservative estimate of the uncertainties we should in principle include all parameters (see earlier comment).

### STUDY 3, SENSITIVITY

#### *Uncertainty Quantification*

Right-click **Uncertainty Quantification** and choose

**Add New Uncertainty Quantification Study For>Uncertainty Propagation.**

### STUDY 4, PROPAGATION

1 In the **Model Builder** window, click **Study 4**.

2 In the **Settings** window for **Study**, type Study 4, Propagation in the **Label** text field.

#### *Uncertainty Quantification*

1 In the **Model Builder** window, under **Study 4, Propagation** click **Uncertainty Quantification**.

2 In the **Settings** window for **Uncertainty Quantification**, locate the **Input Parameters** section.

3 Ctrl-click to select table rows 1, 2, 4, 6, and 7. This is most easily done by first clicking in the table's upper-left corner and then dragging the bottom border of the pop-out table downward until you see all rows at once. The rows to select are those for the parameters ts, lp, hm, wf, and r1.

4 Click  **Delete**.

5 Locate the **Uncertainty Quantification Settings** section. From the **Compute action** list, choose **Compute and analyze**. The default **Compute action** is **Improve and analyze**. This will reuse the previously computed uncertainty quantification results in order to speed up the computation. However, we are changing to **Compute and analyze**, which is slower, but gives a higher-fidelity result.

#### *Uncertainty Quantification 3*

In the **Home** toolbar, click  **Compute**.

## RESULTS

### Kernel Density Estimation, $\text{comp1}.\phi$

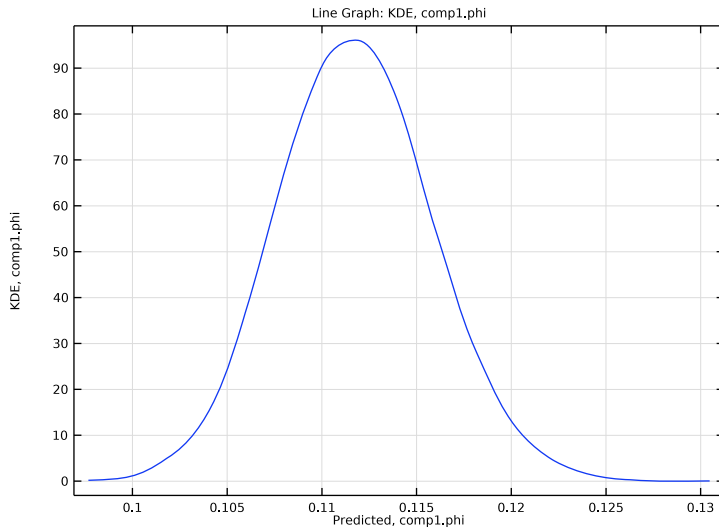

The uncertainty propagation study computes a so-called kernel density estimation or KDE. You can think of the KDE as a smooth form of a histogram showing an estimate of the probability density function of the quantity of interest, given the input parameters and their distributions. We can see from the QoI confidence interval table, shown earlier in the [Results and Discussion](#) section, that the mean is about 0.11 degree with a standard deviation of 0.004 degree. The KDE plot gives us this information graphically. From the values in the table we can also see that there appears to be some risk that the angle exceeds 0.12 degree.

To get a more accurate estimate of the risk for exceeding 0.12 degree, we will next run a reliability analysis.

## STUDY 4, PROPAGATION

### Uncertainty Quantification

Right-click **Uncertainty Quantification** and choose

**Add New Uncertainty Quantification Study For>Reliability Analysis.**

## STUDY 5, RELIABILITY

**1** In the **Model Builder** window, click **Study 5**.

**2** In the **Settings** window for **Study**, type Study 5, Reliability in the **Label** text field.

#### Uncertainty Quantification

- 1 In the **Model Builder** window, under **Study 5, Reliability** click **Uncertainty Quantification**.
- 2 In the **Settings** window for **Uncertainty Quantification**, locate the **Quantities of Interest** section.
- 3 In the table, enter the following settings:

Expression	Individual solution to use	True if	Threshold
comp1.phi	From "Solution to use"	Larger than threshold	0.12

#### Uncertainty Quantification 4

- 1 In the **Home** toolbar, click  **Compute**.

The reliability analysis performs a so-called importance sampling that refines the full model results near the threshold that we give for our quantity of interest. Recall that we are here asking for the probability that this angle exceeds 0.12 degree. The reliability analysis study gives us a table named **Probability for condition** having the value  $\sim 0.022$ . This means that with the given conditions, there is a  $\sim 2.2\%$  risk of the misalignment angle to exceed 0.12 degree.

As a final step, we can also produce a response surface of pairs of input parameters, in this case the Side length (1s) and the Cross plate width (wp) .

#### Uncertainty Quantification

- 1 In the **Model Builder** window, under **Study 5, Reliability** click **Uncertainty Quantification**.
- 2 Locate the **Surrogate-Based Response Surface** section. Click **Response Surface** in the upper-right corner of the section.



**RESULTS**

*Response surface*

Click the  **Zoom Extents** button in the **Graphics** toolbar.

