



Radome with Double-Layered Dielectric Lens

Introduction

A radome is an enclosure for protecting an antenna from the environment. It should be almost completely RF transparent, and can be designed to improve radiation characteristics such as antenna directivity. Here a radome, as shown in [Figure 1](#), improves the gain of a patch antenna.

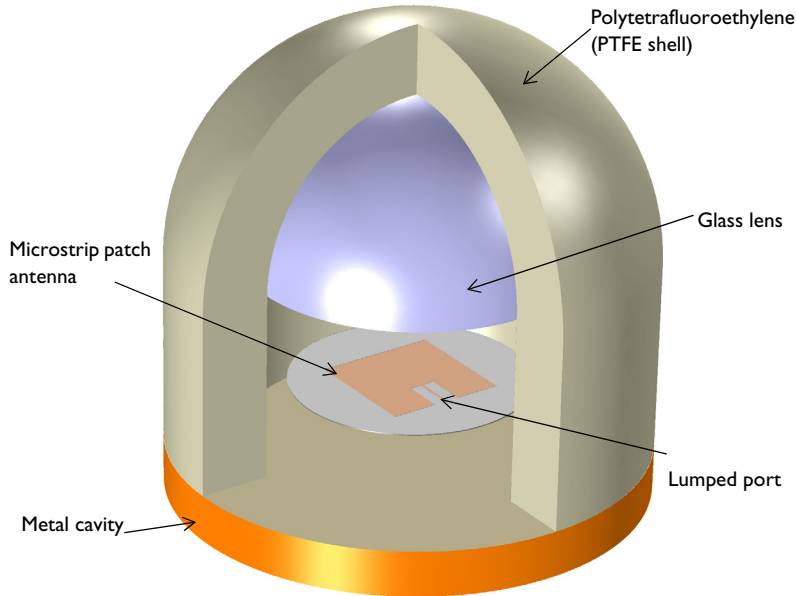

Figure 1: A microstrip patch antenna enclosed by dielectric medium. A double-layered dielectric lens is placed at the boresight of the antenna and confines the fields to increase the antenna gain.

Model Definition

The model shown in [Figure 1](#) represents the radome enclosing a patch antenna. The patch antenna is a thin layer of metal, sitting on a circular dielectric above a ground plane. The antenna and ground plane are modeled as infinitely thin perfect electric conductor (PEC) surfaces. The antenna itself is fed by a 50Ω lumped port, representing a feed from the power source.

The entire structure is enclosed in a cylindrical PTFE housing, capped by a half-spherical shell. Within this, a half-sphere of a quartz glass dielectric is used to increase the antenna gain. The PTFE housing is backed by a metal housing, also modeled as PEC surfaces. The structure is designed to operate at 1.632 GHz.

The entire antenna structure is modeled within a sphere with the properties of vacuum. This sphere is truncated by a perfectly matched layer (PML) domain that acts as a boundary to free space. The distance from the antenna to the PML is a variable that does require some study. The PML should not be within the reactive near-field region of the antenna structure. However, the size of the reactive near field is not strictly definable, so the distance from the antenna to the PML should be studied for each model. The thickness of the PML itself is not critical, and can be made approximately one tenth of the air sphere diameter.

The meshing of radiating structures requires some care. As a rule of thumb, use at least five elements per wavelength in each material, although if absolutely necessary, as few as three elements can do. Furthermore, curved edges and surfaces should be meshed with at least two elements per 90° chord, and the stricter of the two criteria should always be used. Additionally, tetrahedral elements of approximately unit aspect ratio are preferable in most modeling regions, with the exception of the PML domains. Because the PML domain preferentially absorbs radiated energy in one direction, the mesh should conform to this. A swept mesh is thus recommended in PML regions.

Results and Discussion

The far-field radiation pattern is shown in [Figure 2](#). The observed radiation pattern is more directive than that of a patch antenna only. [Figure 4](#) shows E-fields that are confined through the radome structure, which results in stronger fields at the center of the top shell. This example model shows that a radome can work as an antenna enclosure and improve the antenna directivity.

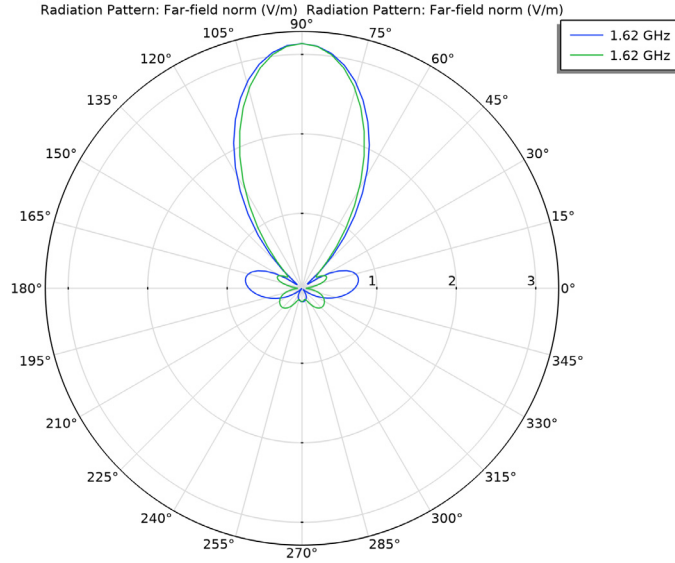

Figure 2: Far-field radiation pattern at the E-plane (blue) and the H-plane (green) at 1.632 GHz. The radiation pattern is more directive than that of a patch antenna.

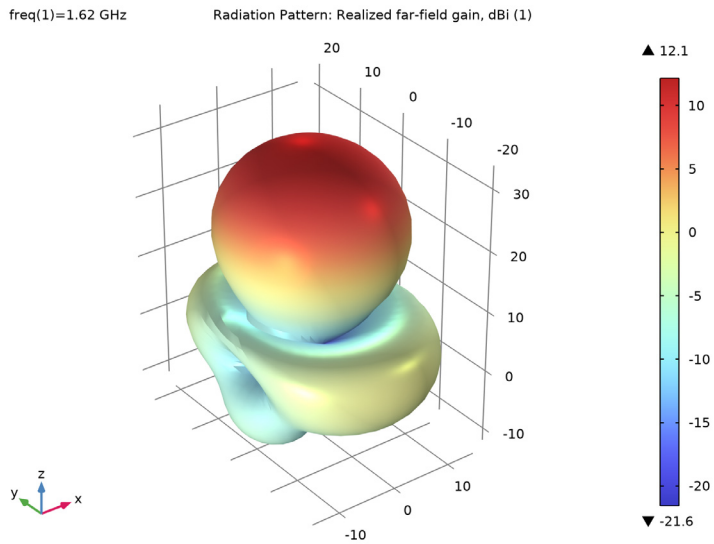

Figure 3: The 3D far-field radiation pattern is directive toward the front side of the radome.

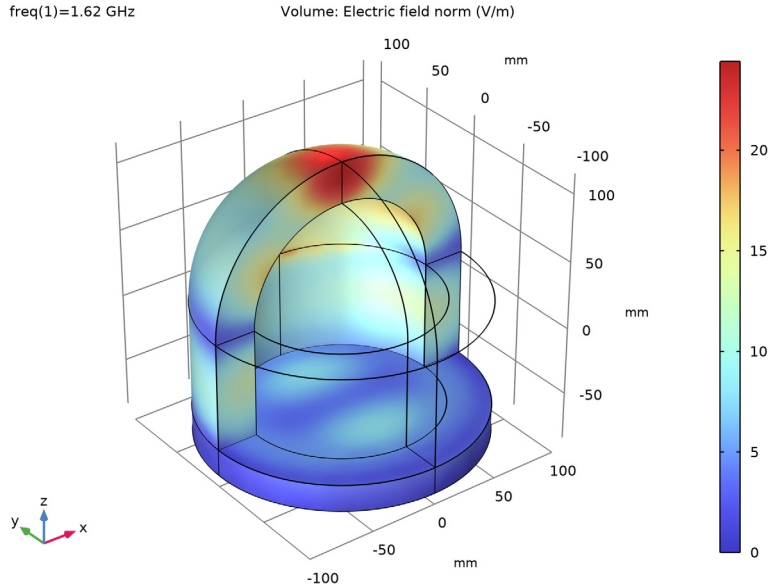

Figure 4: E-field distribution on the radome shell. Note the strong fields at the center of the top radome shell.

References

1. D.M. Pozar, *Microwave Engineering*, John Wiley & Sons, 1998.
2. M. Skolnik, *Introduction to Radar Systems*, McGraw-Hill, 1980.
3. F.T. Ulaby, *Fundamentals of Applied Electromagnetics*, Prentice Hall, 1997.

Application Library path: RF_Module/Antennas/radome_antenna



Modeling Instructions

From the **File** menu, choose **New**.

NEW

In the **New** window, click  **Model Wizard**.

MODEL WIZARD

- 1 In the **Model Wizard** window, click  **3D**.
- 2 In the **Select Physics** tree, select **Radio Frequency>Electromagnetic Waves, Frequency Domain (emw)**.
- 3 Click **Add**.
- 4 Click  **Study**.
- 5 In the **Select Study** tree, select **General Studies>Frequency Domain**.
- 6 Click  **Done**.

STUDY I

Step 1: Frequency Domain

- 1 In the **Model Builder** window, under **Study I** click **Step 1: Frequency Domain**.
- 2 In the **Settings** window for **Frequency Domain**, locate the **Study Settings** section.
- 3 In the **Frequencies** text field, type 1.62[GHz].

GLOBAL DEFINITIONS

Parameters I

- 1 In the **Model Builder** window, under **Global Definitions** click **Parameters I**.
- 2 In the **Settings** window for **Parameters**, locate the **Parameters** section.
- 3 Click  **Load from File**.
- 4 Browse to the model's Application Libraries folder and double-click the file `radome_antenna_parameters.txt`.

mil refers to the unit milliinch. The evaluated impedance of the 1.13 mm feed line on a 20 mil substrate is approximately 50Ω.

GEOMETRY I

- 1 In the **Model Builder** window, under **Component 1 (comp1)** click **Geometry I**.
- 2 In the **Settings** window for **Geometry**, locate the **Units** section.
- 3 From the **Length unit** list, choose **mm**.

First, create a block for the patch.



Patch

- 1 In the **Geometry** toolbar, click  **Block**.
- 2 In the **Settings** window for **Block**, type Patch in the **Label** text field.

- 3 Locate the **Size and Shape** section. In the **Width** text field, type w_{patch} .
- 4 In the **Depth** text field, type l_{patch} .
- 5 In the **Height** text field, type *thickness*.
- 6 Locate the **Position** section. From the **Base** list, choose **Center**.
- 7 In the **z** text field, type -40 .
- 8 Click  **Build Selected**.



Add a block for the tuning stub.

Stub

- 1 In the **Geometry** toolbar, click  **Block**.
- 2 In the **Settings** window for **Block**, type *Stub* in the **Label** text field.
- 3 Locate the **Size and Shape** section. In the **Width** text field, type w_{tuning} .
- 4 In the **Depth** text field, type l_{tuning} .
- 5 In the **Height** text field, type *thickness*.
- 6 Locate the **Position** section. From the **Base** list, choose **Center**.
- 7 In the **x** text field, type $w_{\text{tuning}}/2 + w_{\text{line}}/2$.
- 8 In the **y** text field, type $l_{\text{tuning}}/2 - 25$.
- 9 In the **z** text field, type -40 .
- 10 Click  **Build Selected**.

Copy the tuning stub. A pair of the tuning stubs is symmetric with respect to the feed line.



Copy 1 (copy1)

- 1 In the **Geometry** toolbar, click  **Transforms** and choose **Copy**.
- 2 Select the object **blk2** only.
- 3 In the **Settings** window for **Copy**, locate the **Displacement** section.
- 4 In the **x** text field, type $-w_{\text{tuning}} - w_{\text{line}}$.
- 5 Click  **Build Selected**.

Subtract the tuning stubs from the patch. This action creates the 50Ω feed line, too.

Difference 1 (dif1)

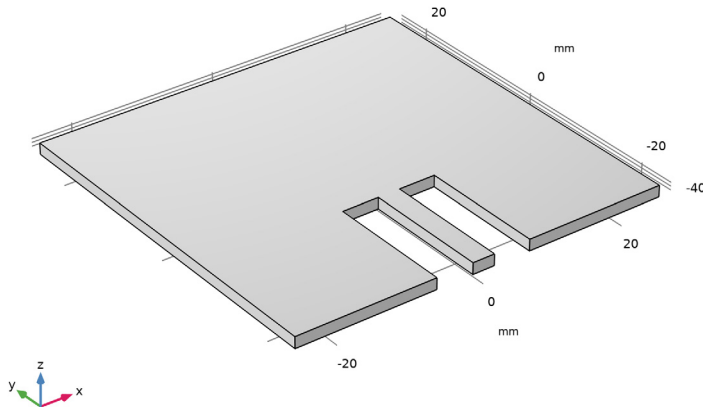

- 1 In the **Geometry** toolbar, click  **Booleans and Partitions** and choose **Difference**.
- 2 Select the object **blk1** only.
- 3 In the **Settings** window for **Difference**, locate the **Difference** section.

- 4 Find the **Objects to subtract** subsection. Click to select the  **Activate Selection** toggle button.
- 5 Select the objects **blk2** and **copy1** only.
- 6 Click  **Build Selected**.



Add a cylinder for the substrate.

Substrate

- 1 In the **Geometry** toolbar, click  **Cylinder**.
- 2 In the **Settings** window for **Cylinder**, type Substrate in the **Label** text field.
- 3 Locate the **Size and Shape** section. In the **Radius** text field, type 50.
- 4 In the **Height** text field, type thickness.
- 5 Locate the **Position** section. In the **z** text field, type $-40 - \text{thickness}/2$.
- 6 Click  **Build Selected**.
- 7 Click the  **Zoom Extents** button in the **Graphics** toolbar.



Create a sphere for the double-layered dielectric lens.

Radome

- 1 In the **Geometry** toolbar, click  **Sphere**.
- 2 In the **Settings** window for **Sphere**, type Radome in the **Label** text field.
- 3 Locate the **Size** section. In the **Radius** text field, type r_{radome} .



- 4 Locate the **Position** section. In the **z** text field, type 15.
- 5 Click to expand the **Layers** section. In the table, enter the following settings:

Layer name	Thickness (mm)
Layer 1	t_radome_wall

- 6 Click  **Build Selected**.
- 7 Click the  **Wireframe Rendering** button in the **Graphics** toolbar.
- 8 Click the  **Zoom Extents** button in the **Graphics** toolbar.



Add a block to cut the bottom half of the above sphere.

Cut Bottom Half

- 1 In the **Geometry** toolbar, click  **Block**.
- 2 In the **Settings** window for **Block**, type Cut Bottom Half in the **Label** text field.
- 3 Locate the **Size and Shape** section. In the **Width** text field, type r_radome*2.5.
- 4 In the **Depth** text field, type r_radome*2.5.
- 5 In the **Height** text field, type r_radome*2.
- 6 Locate the **Position** section. From the **Base** list, choose **Center**.
- 7 In the **z** text field, type -85.
- 8 Click  **Build Selected**.

Create a hemisphere by subtracting the above block from the dielectric lens sphere.

Radome Top

- 1 In the **Geometry** toolbar, click  **Booleans and Partitions** and choose **Difference**.
- 2 In the **Settings** window for **Difference**, type Radome Top in the **Label** text field.
- 3 Select the object **sph1** only.
- 4 Locate the **Difference** section. Find the **Objects to subtract** subsection. Click to select the  **Activate Selection** toggle button.
- 5 Select the object **blk3** only.
- 6 Click  **Build Selected**.

Create a cylinder with a layer for the side wall of the radome.

Radome Wall

- 1 In the **Geometry** toolbar, click  **Cylinder**.
- 2 In the **Settings** window for **Cylinder**, type Radome Wall in the **Label** text field.



- 3 Locate the **Size and Shape** section. In the **Radius** text field, type r_{radome} .
- 4 In the **Height** text field, type $h_{\text{radome_wall}}$.
- 5 Locate the **Position** section. In the **z** text field, type -65 .
- 6 Click to expand the **Layers** section. In the table, enter the following settings:

Layer name	Thickness (mm)
Layer 1	30

- 7 Click  **Build Selected**.

Create a cylinder for the bottom part of the radome.

Radome Bottom

- 1 In the **Geometry** toolbar, click  **Cylinder**.
- 2 In the **Settings** window for **Cylinder**, type Radome Bottom in the **Label** text field.
- 3 Locate the **Size and Shape** section. In the **Radius** text field, type r_{radome} .
- 4 In the **Height** text field, type $t_{\text{radome_bottom}}$.
- 5 Locate the **Position** section. In the **z** text field, type -85 .
- 6 Click  **Build Selected**.

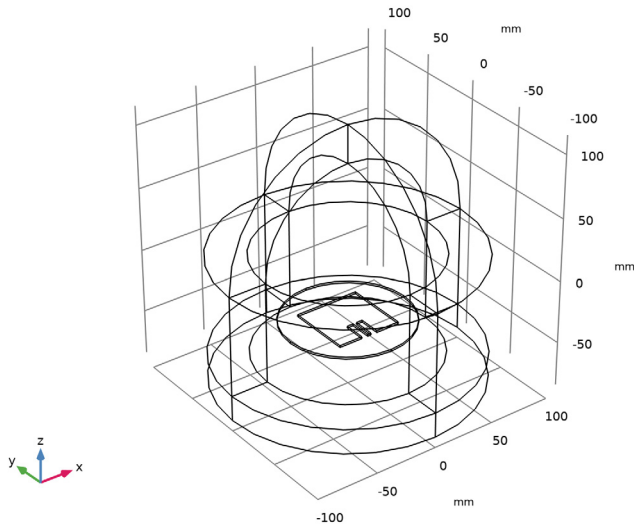

Create a sphere for the PMLs.

PMLs

- 1 In the **Geometry** toolbar, click  **Sphere**.
- 2 In the **Settings** window for **Sphere**, type PMLs in the **Label** text field.
- 3 Locate the **Size** section. In the **Radius** text field, type 190.
- 4 Locate the **Layers** section. In the table, enter the following settings:

Layer name	Thickness (mm)
Layer 1	30

- 5 Click  **Build All Objects**.

DEFINITIONS

Add a selection for the radome.

Radome

- 1 In the **Definitions** toolbar, click  **Explicit**.
- 2 In the **Settings** window for **Explicit**, type Radome in the **Label** text field.
- 3 Select Domains 6–10, 17, 18, 20, and 22 only.

These are the visible domains from the default 3D view. Domain 7 and 9 are hidden in this figure.

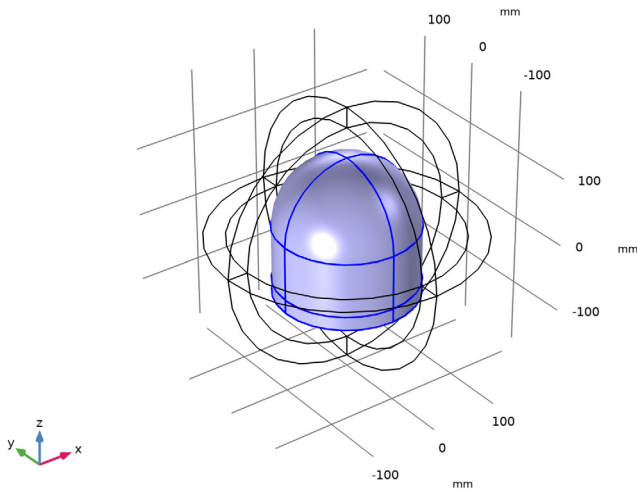

Perfectly Matched Layer 1 (pml1)

- 1 In the **Definitions** toolbar, click  **Perfectly Matched Layer**.

- 2 Select Domains 1–4, 15, 16, 19, and 21 only.
- 3 In the **Settings** window for **Perfectly Matched Layer**, locate the **Geometry** section.
- 4 From the **Type** list, choose **Spherical**.

Hide some boundaries and domains to get a better view of the interior parts.

DEFINITIONS

Hide for Physics 1

- 1 In the **Model Builder** window, right-click **View 1** and choose **Hide for Physics**.
- 2 Select Domains 1, 2, 15, and 16 only.

Hide for Physics 2

- 1 Right-click **View 1** and choose **Hide for Physics**.
- 2 Select Domains 7, 9, 17, and 18 only.

Hide for Physics 3

- 1 Right-click **View 1** and choose **Hide for Physics**.
- 2 In the **Settings** window for **Hide for Physics**, locate the **Geometric Entity Selection** section.
- 3 From the **Geometric entity level** list, choose **Boundary**.
- 4 Click  **Paste Selection**.
- 5 In the **Paste Selection** dialog box, type 9-10, 17, 24, 26, 29-30, 50-51, 54, 58-60 in the **Selection** text field.
- 6 Click **OK**.

ELECTROMAGNETIC WAVES, FREQUENCY DOMAIN (EMW)

Perfect Electric Conductor 2

- 1 In the **Model Builder** window, under **Component 1 (comp1)** right-click **Electromagnetic Waves, Frequency Domain (emw)** and choose the boundary condition **Perfect Electric Conductor**.
- 2 In the **Settings** window for **Perfect Electric Conductor**, locate the **Boundary Selection** section.
- 3 Click  **Paste Selection**.
- 4 In the **Paste Selection** dialog box, type 13-15, 34, 38-39, 52, 79 in the **Selection** text field.
- 5 Click **OK**.

Far-Field Domain 1

In the **Physics** toolbar, click  **Domains** and choose **Far-Field Domain**.

Lumped Port 1

1 In the **Physics** toolbar, click  **Boundaries** and choose **Lumped Port**.

2 Select Boundary 44 only.

For the first port, wave excitation is **on** by default.

Zoom to see the port boundary clearly.

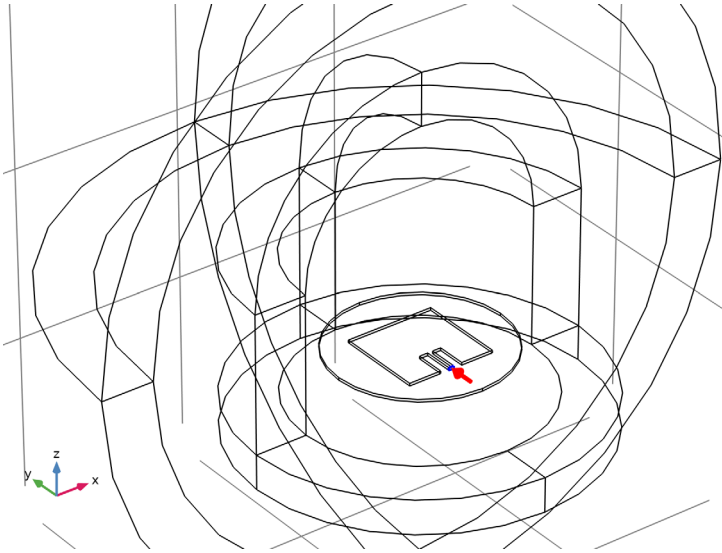

MATERIALS

Assign material properties on the model. First, set all domains with the built-in air.

ADD MATERIAL

1 In the **Home** toolbar, click  **Add Material** to open the **Add Material** window.

2 Go to the **Add Material** window.

3 In the tree, select **Built-in>Air**.

4 Click **Add to Component** in the window toolbar.

MATERIALS

Override the substrate with the dielectric material of $\epsilon_r = 3.38$.

Substrate

- 1 In the **Model Builder** window, under **Component 1 (comp1)** right-click **Materials** and choose **Blank Material**.
- 2 In the **Settings** window for **Material**, type Substrate in the **Label** text field.
- 3 Select Domains 13 and 14 only.
- 4 Locate the **Material Contents** section. In the table, enter the following settings:

Property	Variable	Value	Unit	Property group
Relative permittivity	epsilon _{r_iso} ; epsilon _{r_ii} = epsilon _{r_iso} , epsilon _{r_ij} = 0	3.38		Basic
Relative permeability	mu _{r_iso} ; mu _{r_ii} = mu _{r_iso} , mu _{r_ij} = 0	1		Basic
Electrical conductivity	sigma _{iso} ; sigma _{ii} = sigma _{iso} , sigma _{ij} = 0	0	S/m	Basic

Override the radome with the PTFE material.

PTFE

- 1 Right-click **Materials** and choose **Blank Material**.
- 2 In the **Settings** window for **Material**, type PTFE in the **Label** text field.
- 3 Locate the **Geometric Entity Selection** section. From the **Selection** list, choose **Radome**.
- 4 Locate the **Material Contents** section. In the table, enter the following settings:

Property	Variable	Value	Unit	Property group
Relative permittivity	epsilon _{r_iso} ; epsilon _{r_ii} = epsilon _{r_iso} , epsilon _{r_ij} = 0	2.1		Basic

Property	Variable	Value	Unit	Property group
Relative permeability	mur_iso ; murii = mur_iso, murij = 0	1	l	Basic
Electrical conductivity	sigma_iso ; sigmai = sigma_iso, sigmaj = 0	0	S/m	Basic

Then, override the lens with glass. Choose from the material library.

ADD MATERIAL

- 1 Go to the **Add Material** window.
- 2 In the tree, select **Built-in>Glass (quartz)**.
- 3 Click **Add to Component** in the window toolbar.
- 4 In the **Home** toolbar, click  **Add Material** to close the **Add Material** window.

MATERIALS

Glass (quartz) (mat4)

Select Domain 12 only.

MESH 1

- 1 In the **Model Builder** window, under **Component 1 (comp1)** right-click **Mesh 1** and choose **Build All**.

2 Click the  **Zoom In** button in the **Graphics** toolbar.

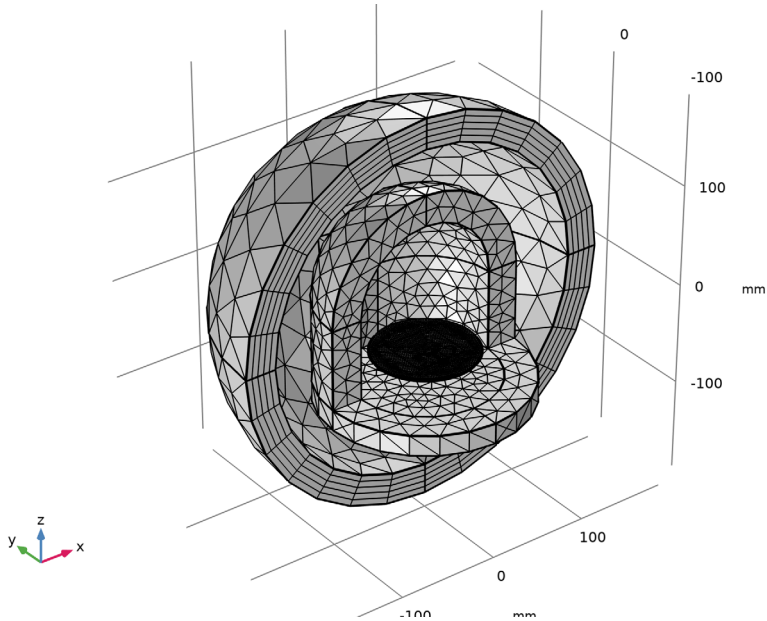

STUDY 1

In the **Home** toolbar, click  **Compute**.



RESULTS

Electric Field (emw)

Begin the results analysis and visualization by modifying the first default plot to show the dB-scaled E-field norm in the xz -plane.

Multislice

- 1 In the **Model Builder** window, expand the **Electric Field (emw)** node, then click **Multislice**.
- 2 In the **Settings** window for **Multislice**, locate the **Expression** section.
- 3 In the **Expression** text field, type $20 * \log_{10}(emw.normE)$.
- 4 Locate the **Multipane Data** section. Find the **Z-planes** subsection. In the **Planes** text field, type 0.
- 5 Find the **X-planes** subsection. In the **Planes** text field, type 0.
- 6 Find the **Y-planes** subsection. From the **Entry method** list, choose **Coordinates**.
- 7 In the **Coordinates** text field, type 0.

- 8 In the **Electric Field (emw)** toolbar, click  **Plot**.
- 9 Click the  **Zoom Extents** button in the **Graphics** toolbar.
- 10 Click the  **Zoom In** button in the **Graphics** toolbar.

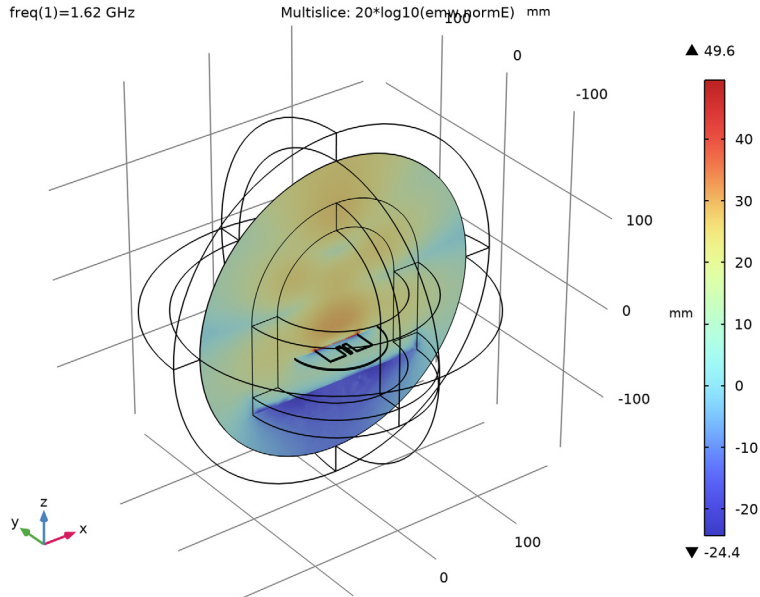

The shape of the field pattern is similar to the H-plane radiation pattern. Adjust the polar plot settings to visualize the far-field pattern on the E-plane.

Radiation Pattern 1

- 1 In the **Model Builder** window, expand the **Results>2D Far Field (emw)** node, then click **Radiation Pattern 1**.
- 2 In the **Settings** window for **Radiation Pattern**, locate the **Evaluation** section.
- 3 Find the **Angles** subsection. In the **Number of angles** text field, type 100.
- 4 Find the **Reference direction** subsection. In the **x** text field, type 0.
- 5 In the **y** text field, type 1.
- 6 Find the **Normal vector** subsection. In the **x** text field, type 1.
- 7 In the **z** text field, type 0.
- 8 In the **2D Far Field (emw)** toolbar, click  **Plot**.

The E-plane in this model is located on the yz -plane where ϕ is measured counterclockwise from the y -axis.

Add the H-plane polar plot.

Radiation Pattern 2

- 1 Right-click **Results>2D Far Field (emw)>Radiation Pattern 1** and choose **Duplicate**.
- 2 In the **Settings** window for **Radiation Pattern**, locate the **Evaluation** section.
- 3 Find the **Reference direction** subsection. In the **x** text field, type 1.
- 4 In the **y** text field, type 0.
- 5 Find the **Normal vector** subsection. In the **x** text field, type 0.
- 6 In the **y** text field, type -1.
- 7 In the **2D Far Field (emw)** toolbar, click  **Plot**.

The H-plane is located on the xz -plane where ϕ is measured counterclockwise from the x -axis.

Compare the resulting plot with that shown in [Figure 2](#).

3D Far Field, Gain (emw)

Compare the 3D far-field radiation pattern plot with [Figure 3](#).

Create a selection of the solution to visualize the E-field only on the radome.

Study 1/Solution 1 (2) (sol1)

In the **Results** toolbar, click  **More Datasets** and choose **Solution**.



Selection

- 1 In the **Results** toolbar, click  **Attributes** and choose **Selection**.
- 2 In the **Settings** window for **Selection**, locate the **Geometric Entity Selection** section.
- 3 From the **Geometric entity level** list, choose **Domain**.
- 4 From the **Selection** list, choose **Radome**.

3D Plot Group 4

- 1 In the **Results** toolbar, click  **3D Plot Group**.
- 2 In the **Settings** window for **3D Plot Group**, locate the **Data** section.
- 3 From the **Dataset** list, choose **Study 1/Solution 1 (2) (sol1)**.

Volume 1

- 1 Right-click **3D Plot Group 4** and choose **Volume**.
- 2 In the **3D Plot Group 4** toolbar, click  **Plot**.
- 3 Click the  **Zoom Extents** button in the **Graphics** toolbar.

4 Click the  **Zoom In** button in the **Graphics** toolbar.

The broad E-field radiation pattern from the patch antenna is confined on the center of the radome top through the double-layered (PTFE+glass) dielectric lens (compare with [Figure 4](#)).

S-parameter (emw)

The antenna input matching property at the simulated frequency is less than -10 dB.

