



Connecting a 3D Electromagnetic Wave Model to an Electrical Circuit

Introduction

An application built with the RF Module can be connected to an electrical circuit equivalent, if there is some structure outside of the model space that you want to approximate as a circuit equivalent. An example is shown in [Figure 1](#), the 3D model of a coaxial cable is connected to a voltage source, in series with a matched impedance, and sees a load, also of matched impedance.

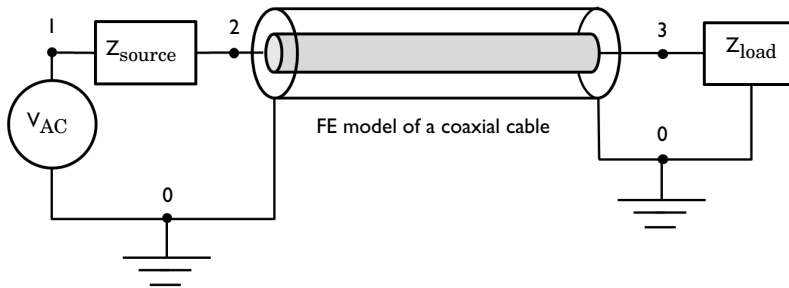

Figure 1: Schematic of a section of a coaxial transmission line connected to a voltage source, source impedance, and load.

Model Definition

The geometry in this example is a short section of a air-filled coaxial transmission line, shown schematically in [Figure 1](#). A 3D modeling space is used to model the coaxial cable. The walls of the coax are treated as perfect electric conductors. This is appropriate when the skin depth, and the losses in the conductors, are insignificant.

At one end of the coaxial cable, Lumped Port boundary condition is used to connect the model to nodes 0 and 2 of the Electrical Circuit. A Voltage Source between circuit nodes 0 and 1 excites the system, and a Resistor representing the source impedance is added between nodes 1 and 2. Node 0 is specified as the Ground Node by default, which fixes the absolute voltage. The connection from the Electrical Circuit model to the Electromagnetic Waves interface is via the External I Vs. U features.

At the other end of the coaxial cable, another Lumped Port boundary condition is used to connect the model to nodes 3 and 0 of the Electrical Circuit. A Resistor which works as a matched load is added between nodes 3 and 0. At any nonzero frequency, the absolute voltage has no well-defined meaning, voltage only has a meaning as the path integral of

electric field between two points, so any arbitrary point in the model can be chosen to have zero voltage. If you are working with a purely RF model, without an electrical circuit, it is not even possible to fix the absolute voltage. However, when using the Electrical Circuit interface, it requires that the absolute voltage be fixed at one node (Node 0) in the model.

Results and Discussion

Figure 2 is a combined plot of the default electric field norm, magnetic field, and power flow.

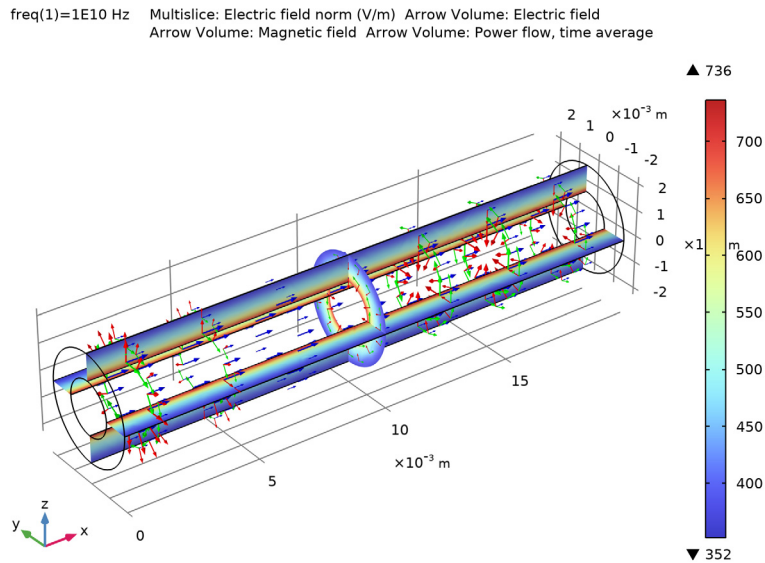

Figure 2: Electric field norm (multislices) and electric field, magnetic field, and power flow (red, green, and blue arrows) inside the coaxial cable.

The fields and power flow plot shows the TEM wave propagation inside the coaxial cable, which is excited by the Electrical Circuit interface.

Notes About the COMSOL Implementation

The Electrical Circuit interface is located under the AD/DC Module branch, but it is included with the RF Module.

Application Library path: RF_Module/Transmission_Lines_and_Waveguides/
coaxial_cable_circuit



Modeling Instructions

From the **File** menu, choose **New**.

NEW

In the **New** window, click  **Model Wizard**.

MODEL WIZARD

- 1 In the **Model Wizard** window, click  **3D**.
- 2 In the **Select Physics** tree, select **Radio Frequency>Electromagnetic Waves, Frequency Domain (emw)**.
- 3 Click **Add**.
- 4 In the **Select Physics** tree, select **AC/DC>Electrical Circuit (cir)**.
- 5 Click **Add**.
- 6 Click  **Study**.
- 7 In the **Select Study** tree, select **General Studies>Frequency Domain**.
- 8 Click  **Done**.

STUDY I

Step 1: Frequency Domain

- 1 In the **Model Builder** window, under **Study I** click **Step 1: Frequency Domain**.
- 2 In the **Settings** window for **Frequency Domain**, locate the **Study Settings** section.
- 3 In the **Frequencies** text field, type 10[GHz].

GLOBAL DEFINITIONS

Parameters 1

- 1 In the **Model Builder** window, under **Global Definitions** click **Parameters 1**.
- 2 In the **Settings** window for **Parameters**, locate the **Parameters** section.

3 In the table, enter the following settings:

Name	Expression	Value	Description
r_coax	1[mm]	0.001 m	Coax inner radius
R_coax	2[mm]	0.002 m	Coax outer radius
L_coax	20[mm]	0.02 m	Length of coax core into cavity
Z_coax	$Z0_const / (2 * \pi) * \log(R_coax / r_coax)$	41.56 Ω	Analytical impedance

Here, Z0_const is a predefined COMSOL constant for the speed of the light and the wave impedance in vacuum, respectively.

GEOMETRY 1

Create the geometry of the coaxial cable using two cylinders.



Coax outer

- 1 In the **Geometry** toolbar, click  **Cylinder**.
- 2 In the **Settings** window for **Cylinder**, type Coax outer in the **Label** text field.
- 3 Locate the **Size and Shape** section. In the **Radius** text field, type R_coax.
- 4 In the **Height** text field, type L_coax.
- 5 Locate the **Axis** section. From the **Axis type** list, choose **x-axis**.

Coax inner

- 1 In the **Geometry** toolbar, click  **Cylinder**.
- 2 In the **Settings** window for **Cylinder**, type Coax inner in the **Label** text field.
- 3 Locate the **Size and Shape** section. In the **Radius** text field, type r_coax.
- 4 In the **Height** text field, type L_coax.
- 5 Locate the **Axis** section. From the **Axis type** list, choose **x-axis**.

Difference 1 (dif1)

- 1 In the **Geometry** toolbar, click  **Booleans and Partitions** and choose **Difference**.
- 2 Select the object **cyl1** only.
- 3 In the **Settings** window for **Difference**, locate the **Difference** section.
- 4 Find the **Objects to subtract** subsection. Click to select the  **Activate Selection** toggle button.
- 5 Select the object **cyl2** only.

6 Click  **Build All Objects**.

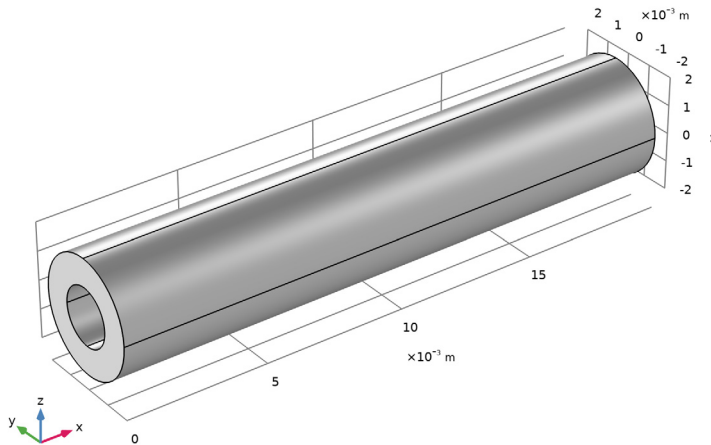

7 Click the  **Wireframe Rendering** button in the **Graphics** toolbar.

ELECTROMAGNETIC WAVES, FREQUENCY DOMAIN (EMW)

Lumped Port 1

1 In the **Model Builder** window, under **Component 1 (comp1)** right-click **Electromagnetic Waves, Frequency Domain (emw)** and choose **Lumped Port**.

2 Select Boundary 1 only.

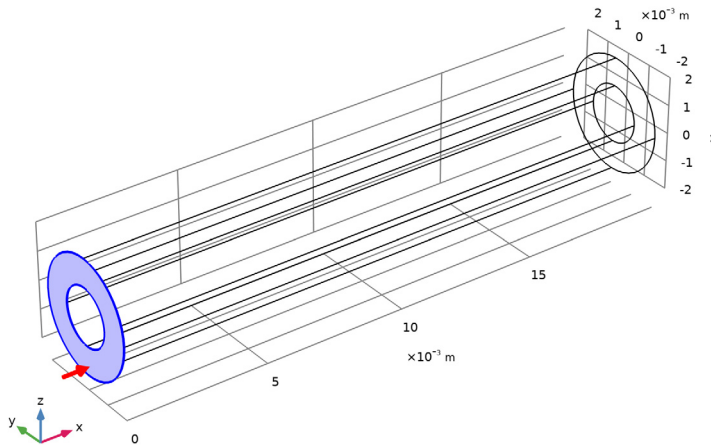

3 In the **Settings** window for **Lumped Port**, locate the **Lumped Port Properties** section.

4 From the **Type of lumped port** list, choose **Coaxial**.

5 From the **Terminal type** list, choose **Circuit**.

Lumped Port 2

1 In the **Physics** toolbar, click  **Boundaries** and choose **Lumped Port**.

2 Select Boundary 10 only.

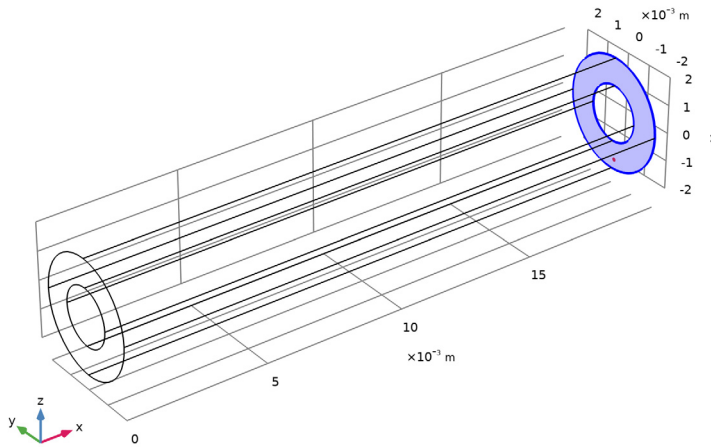

3 In the **Settings** window for **Lumped Port**, locate the **Lumped Port Properties** section.

4 From the **Type of lumped port** list, choose **Coaxial**.

5 From the **Terminal type** list, choose **Circuit**.

ELECTRICAL CIRCUIT (CIR)

In the **Model Builder** window, under **Component 1 (comp1)** click **Electrical Circuit (cir)**.

Voltage Source 1 (V1)

1 In the **Electrical Circuit** toolbar, click  **Voltage Source**.

2 In the **Settings** window for **Voltage Source**, locate the **Node Connections** section.

3 In the table, enter the following settings:

Label	Node names
p	1
n	0

4 Locate the **Device Parameters** section. From the **Source type** list, choose **AC-source**.

Resistor 1 (R1)

1 In the **Electrical Circuit** toolbar, click  **Resistor**.

2 In the **Settings** window for **Resistor**, locate the **Node Connections** section.

3 In the table, enter the following settings:

Label	Node names
p	1
n	2

4 Locate the **Device Parameters** section. In the R text field, type Z_{coax} .

Resistor 2 (R2)

1 In the **Electrical Circuit** toolbar, click  **Resistor**.

2 In the **Settings** window for **Resistor**, locate the **Node Connections** section.

3 In the table, enter the following settings:

Label	Node names
p	3
n	0

4 Locate the **Device Parameters** section. In the R text field, type Z_{coax} .

External I vs. U 1 (IvsU1)

1 In the **Electrical Circuit** toolbar, click  **External I vs. U**.

2 In the **Settings** window for **External I vs. U**, locate the **Node Connections** section.

3 In the table, enter the following settings:

Label	Node names
p	2
n	0

4 Locate the **External Device** section. From the V list, choose **Lumped port voltage (emw/lport1)**.

External I vs. U 2 (IvsU2)

1 In the **Electrical Circuit** toolbar, click  **External I vs. U**.

2 In the **Settings** window for **External I vs. U**, locate the **Node Connections** section.

3 In the table, enter the following settings:



Label	Node names
p	3
n	0

- 4 Locate the **External Device** section. From the V list, choose **Lumped port voltage (emw/lport2)**.

MATERIALS

Next, assign material properties on the model. Specify air for the coaxial cable.

ADD MATERIAL

- 1 In the **Home** toolbar, click  **Add Material** to open the **Add Material** window.
- 2 Go to the **Add Material** window.
- 3 In the tree, select **Built-in>Air**.
- 4 Click **Add to Component** in the window toolbar.
- 5 In the **Home** toolbar, click  **Add Material** to close the **Add Material** window.

MESH 1

- 1 In the **Model Builder** window, under **Component 1 (comp1)** click **Mesh 1**.
- 2 In the **Settings** window for **Mesh**, locate the **Physics-Controlled Mesh** section.
- 3 From the **Element size** list, choose **Fine**.
- 4 Click  **Build All**.

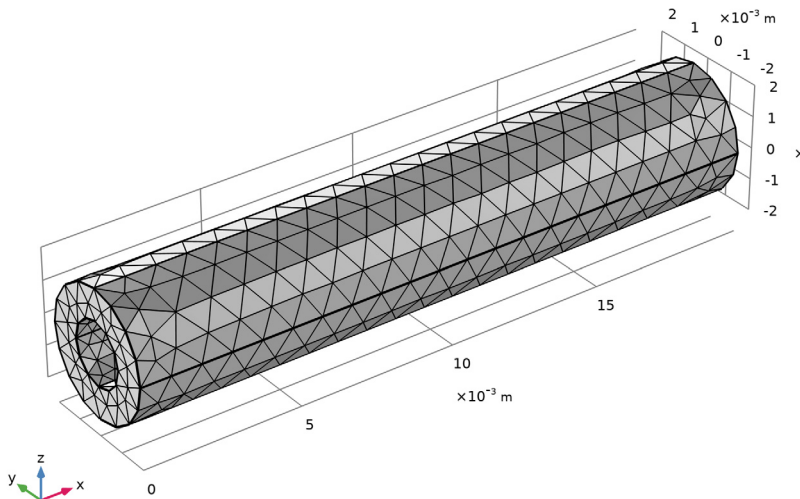

STUDY 1

In the **Home** toolbar, click  **Compute**.

RESULTS

Electric Field (emw)

The default plot shows the E-field norm inside the coaxial cable. Add arrow plots for the electric field, magnetic field, and power flow.

Arrow Volume 1

Right-click **Electric Field (emw)** and choose **Arrow Volume**.

Arrow Volume 2

- 1 Right-click **Electric Field (emw)** and choose **Arrow Volume**.
- 2 In the **Settings** window for **Arrow Volume**, click **Replace Expression** in the upper-right corner of the **Expression** section. From the menu, choose **Component 1 (comp1)> Electromagnetic Waves, Frequency Domain>Magnetic>emw.Hx,emw.Hy,emw.Hz - Magnetic field**.
- 3 Locate the **Coloring and Style** section. From the **Color** list, choose **Green**.

Arrow Volume 3

- 1 Right-click **Electric Field (emw)** and choose **Arrow Volume**.
- 2 In the **Settings** window for **Arrow Volume**, click **Replace Expression** in the upper-right corner of the **Expression** section. From the menu, choose **Component 1 (comp1)> Electromagnetic Waves, Frequency Domain>Energy and power>emw.Poavx,...,emw.Poavz - Power flow, time average**.
- 3 Locate the **Coloring and Style** section. From the **Color** list, choose **Blue**.

4 In the **Electric Field (emw)** toolbar, click  **Plot**.

freq(1)=1E10 Hz Multislice: Electric field norm (V/m) Arrow Volume: Electric field
Arrow Volume: Magnetic field Arrow Volume: Power flow, time average

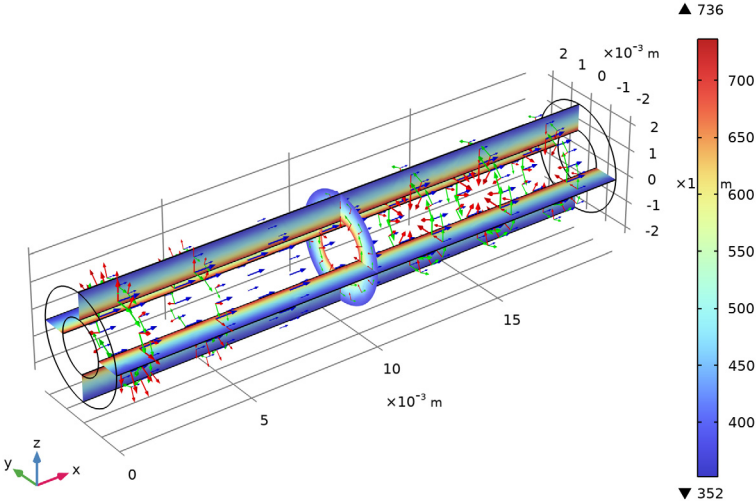

Compare the resulting plot with that shown in [Figure 2](#).