



Corrosion Protection of an Oil Platform Using Sacrificial Anodes

Introduction

Steel structures immersed in seawater can be protected from corrosion through cathodic protection. This protection can be achieved by an impressed external current or by using sacrificial anodes. The use of sacrificial anodes is often preferred due to its simplicity.

The principle for cathodic protection using sacrificial anodes is quite simple: the steel structure is electronically connected to a less noble metal, for example aluminum, which causes the sacrificial anode to be anodically polarized and the steel structure to be cathodically polarized when the electrodes are immersed in seawater. The anodes are dissolved through anodic dissolution of the metal while oxygen reduction takes place at the surface of the steel structure. The supply of oxygen is what often limits the current density for oxygen reduction, which means that a limiting current of an almost constant value over a few hundreds of millivolts in potential is obtained at the surface of the steel structure.

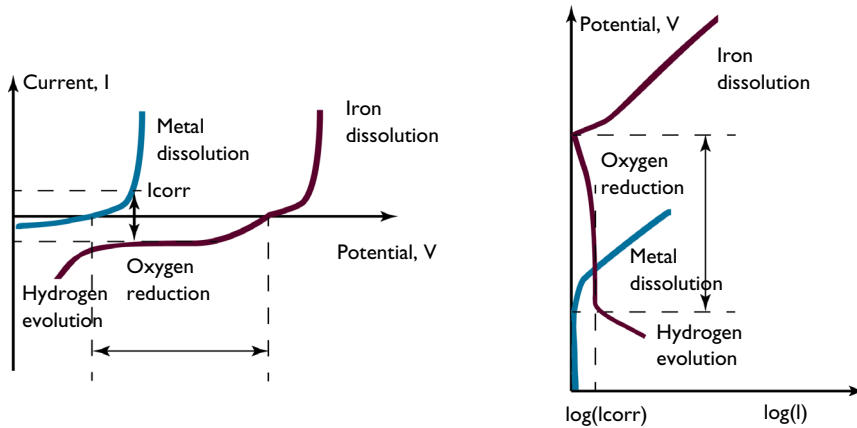

Figure 1: Polarization behavior of the sacrificial anodes (blue) and steel surface (red).

Figure 1 above shows the schematic polarization of the sacrificial anodes and of the oxygen reduction reaction at the surface of the steel structure. The red curve represents the polarization of the steel surface while the blue curve is the polarization of the sacrificial anode. On the left, the currents at the steel structure (red) and at the sacrificial anodes (blue) are plotted as functions of the electric potential measured relative to a common reference. The plot to the right shows the electric potential as a function of the logarithm of the absolute value of the current. As shown in the left graphs, oxygen reduction is achieved at the steel surface along the range of the cathodic limiting current represented by the flat horizontal part of the red curve. In the right plot, the vertical part of the red

curve represents oxygen reduction. The system operates at the point where the cathodic current (red) is equal in size (but opposite in sign) as the anodic current.

The shape of the blue curve changes depending on the number and design of the anodes in the system, and the designer of the system needs to ensure that the different parts of the steel structure are well within the corrosion protected range of potentials (the “flat” part of the red cathodic curve); otherwise the structure is not fully protected and may start to corrode. The width of the oxygen reduction part of the curve is a few hundred millivolts. In addition, the anodes have to be able to deliver the required potential to keep the given current.

The first step in the design of a cathodic protection system is therefore to investigate the potential of the steel structure assuming a constant cathodic current (oxygen reduction). The potential has to be well within the required range where oxygen reduction protects the structure and also avoiding hydrogen evolution, which may eventually cause hydrogen embrittlement.

This example is based on a Recommended Practice for Cathodic Protection Design by DNV ([Ref. 1](#)).

Model Definition

[Figure 2](#) and [Figure 3](#) show the model geometry. The sacrificial anodes are placed relatively close to the oil platform. The radius of the inner cylinder is chosen so that the main part of the charge transport occurs within this cylinder. The outer cylinder is modeled

as an infinite Element Domain, which rescales the equations to represent an approximately thousand times larger cylinder.

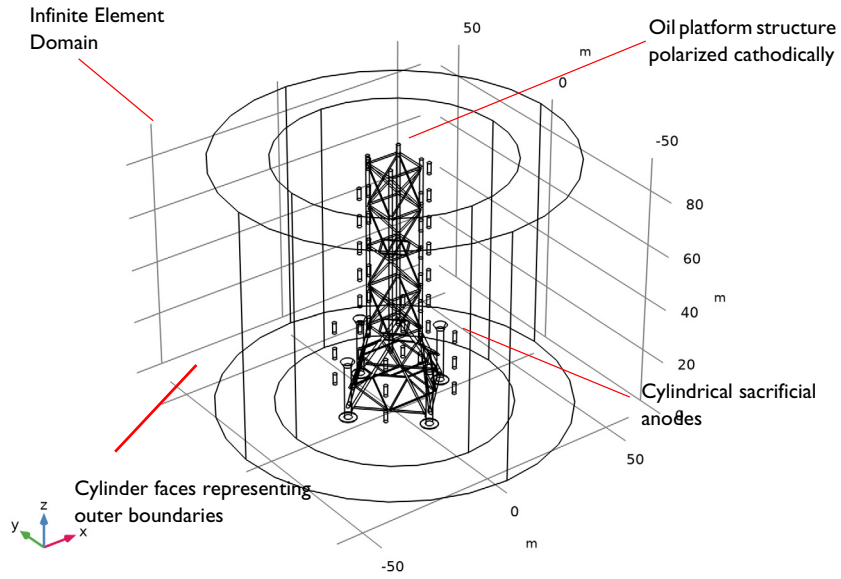

Figure 2: Model geometry.

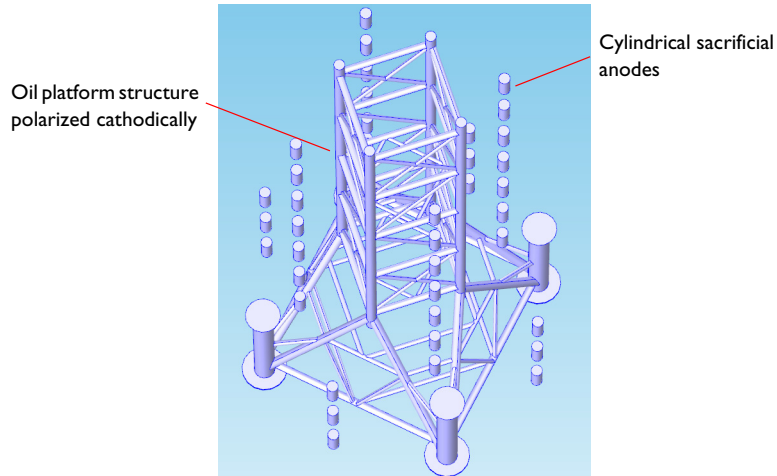

Figure 3: Close-up view of the cylindrical sacrificial anodes and the oil platform structure.

In seawater, the composition is assumed to vary to a very small extent and diffusion of the ions that carry the current is negligible compared to the contribution from migration of these ions in the electric field. This assumption, together with the boundary conditions, allows using a primary current density distribution analysis on the system where only the influence of ohmic effects in the given geometry are taken into account.

At the sacrificial anode surfaces, a constant potential is set assuming a relatively fast kinetics. This assumption implies that a very small change in surface overpotential leads to a very large change in current density and it is therefore reasonable to set a constant potential. Grounding the electronic phase potential (setting it to zero), the boundary condition for the electrolyte phase potential is:

$$\phi_{l, \text{anode}} = \phi_s - E_{\text{eq, Al}} = -E_{\text{eq, Al}} \quad (1)$$

The value for the equilibrium potential of the aluminum anodes is -1.05 V vs Ag/AgCl in this model.

At the steel surface, it is assumed that oxygen reduction takes place at a limiting current density, limited to the rate of transport of dissolved oxygen to the surface, and that the surface is sufficiently protected so that metal dissolution currents can be neglected. This yields a constant normal current density boundary condition at the steel surfaces of the structure. The boundary condition for the steel surface is:

$$-\mathbf{n} \cdot \mathbf{i}_l = i_{\text{lim, oxygen}} \quad (2)$$

The value for the limiting current is 0.1 A/m^2 in this model.

All other boundaries are insulated.

The model can be easily extended to a more advanced (secondary) current density distribution analysis in order to add the kinetics of the electrode reactions in a second stage, see for instance the [Anode Film Resistance Effect on Cathodic Corrosion Protection](#) example. A tertiary current density distribution analysis that also accounts for the transport of charged species is also possible in the Corrosion Module, although this would require the use of different physics interfaces.

Results and Discussion

[Figure 4](#) shows a slice plot of the potential in the electrolyte, ϕ_l . The potential close to the steel structure surface varies several hundreds of millivolts, depending on position. The

further the distance from an anode – the lower the potential, an expected result since the current in the electrolyte flows from the anodes to the steel cathode.

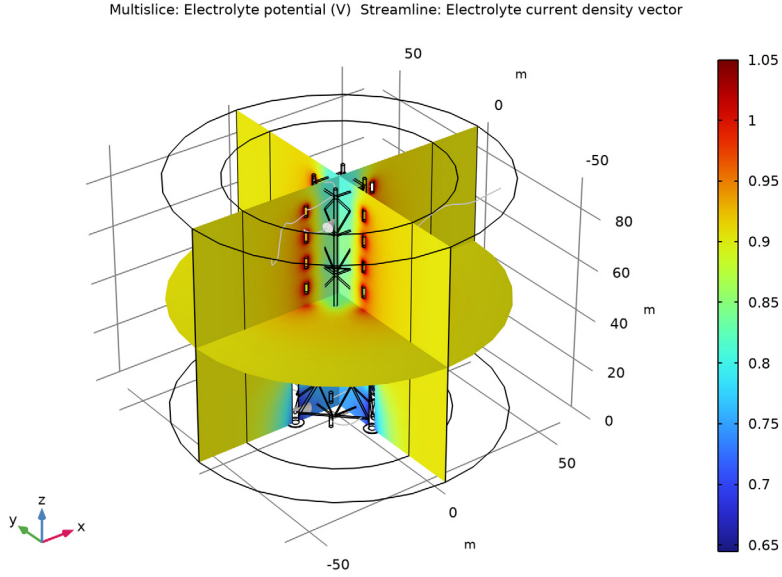

Figure 4: Slice plot of the electrolyte potential.

One can relate the electrolyte potential, ϕ_1 , to the electrode potential, shown in Figure 1, by considering a reference electrode placed in the electrolyte in close vicinity to the steel surface. The electric potential of a reference electrode, $\phi_{s,\text{ref}}$, is

$$\phi_{s,\text{ref}} = E_{\text{eq,ref}} + \phi_1 \quad (3)$$

The electric potential of the steel surface, ϕ_s , is constant due to the high conductivity of the metal, and the potential of the steel surface versus the reference electrode becomes

$$E_{\text{steel vs ref}} = \phi_{s,\text{steel}} - \phi_{s,\text{ref}} = \phi_{s,\text{steel}} - E_{\text{eq,ref}} - \phi_1 \quad (4)$$

In this model we chose the metal potential as ground, and assuming a Ag/AgCl reference we get:

$$E_{\text{steel vs Ag/AgCL}} = -\phi_1 \quad (5)$$

Figure 5 shows the potential of the steel surface according to Equation 5. The parts of the steel surface with the highest (most anodic) values in this plot are the least protected.

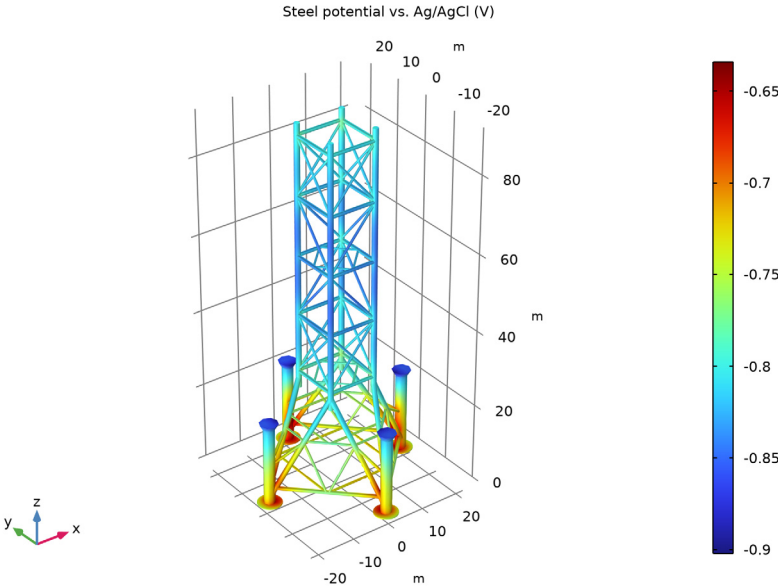

Figure 5: Steel platform potential vs a Ag/AgCl reference.

Figure 6 shows a close-up of one of the structure legs. The inside bottom part of the leg is the part most susceptible to corrosion.

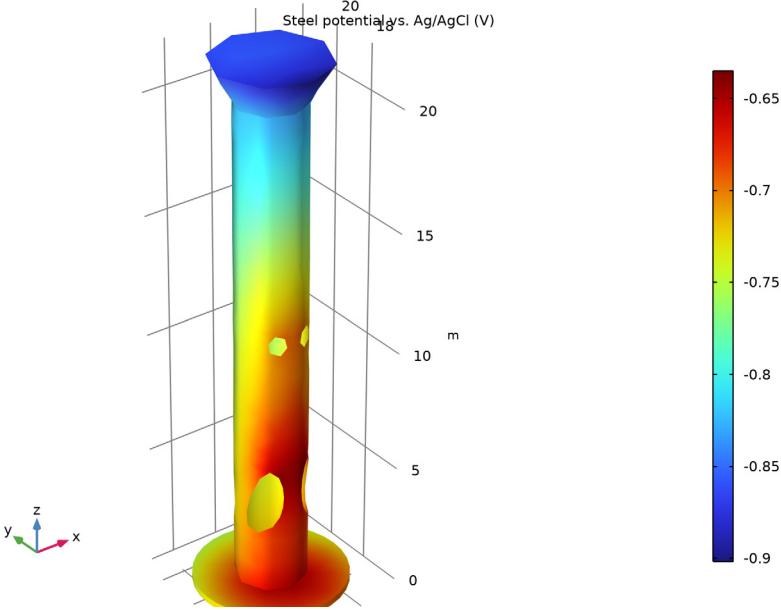

Figure 6: Potential on one of the legs of the platform structure.

Finally, [Figure 7](#) shows the current densities on the anodes, which are of interest because their magnitudes are directly proportional to the consumption rate of the anode metal. The highest current density for the anodes is about four times the lowest current density.

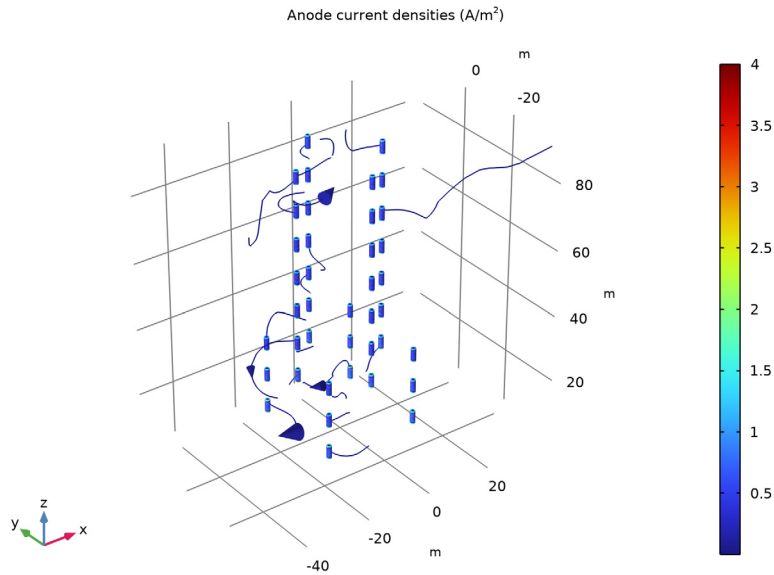

Figure 7: Current densities on the anodes.

Reference

1. Det Norske Veritas, *Recommended Practice Cathodic Protection Design, NDV-RP-B401*, October 2010.

Application Library path: Corrosion_Module/Cathodic_Protection/
oil_platform



Modeling Instructions

From the **File** menu, choose **New**.

NEW

In the **New** window, click  **Model Wizard**.

MODEL WIZARD

- 1 In the **Model Wizard** window, click  **3D**.
- 2 In the **Select Physics** tree, select **Electrochemistry>Cathodic Protection (cp)**.
- 3 Click **Add**.
- 4 Click  **Study**.
- 5 In the **Select Study** tree, select **General Studies>Stationary**.
- 6 Click  **Done**.

GLOBAL DEFINITIONS

Add some parameters for use in the model.

Parameters 1



- 1 In the **Model Builder** window, under **Global Definitions** click **Parameters 1**.
- 2 In the **Settings** window for **Parameters**, locate the **Parameters** section.
- 3 In the table, enter the following settings:

Name	Expression	Value	Description
i_oxygen	-0.1[A/m ²]	-0.1 A/m ²	Limiting current for oxygen reduction at steel structure
Eeq_A1	-1.05[V]	-1.05 V	Anode equilibrium potential vs. Ag/AgCl

GEOMETRY 1

Import the geometry of the oil platform from a geometry file.

Import 1 (impl)

- 1 In the **Home** toolbar, click  **Import**.
- 2 In the **Settings** window for **Import**, locate the **Import** section.
- 3 Click  **Browse**.
- 4 Browse to the model's Application Libraries folder and double-click the file oil_platform.mphbin.
- 5 Click  **Import**.
- 6 Locate the **Selections of Resulting Entities** section. Select the **Resulting objects selection** check box.
- 7 From the **Show in physics** list, choose **Boundary selection**.
- 8 Select the **Individual object selections** check box.

9 From the **Show in physics** list, choose **Boundary selection**.

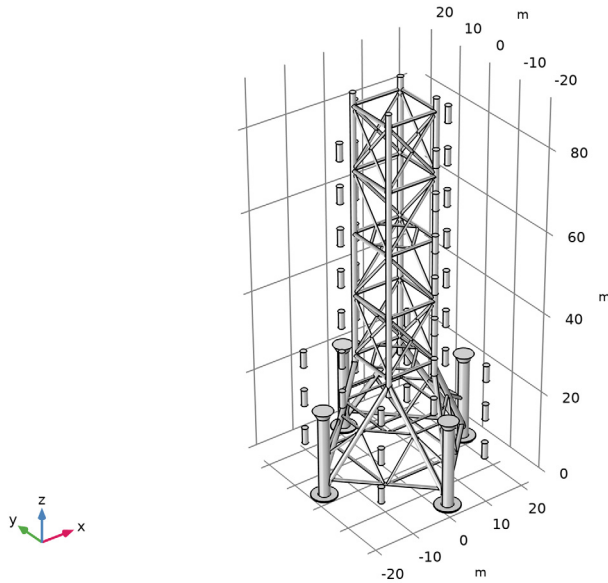

This generates selections of the imported geometry, which you will use later on when setting up the physics on the boundaries (the anodes and the steel structure).

10 Click  **Build Selected**.



Cylinder 1 (cyl1)

Add a surrounding cylinder around the platform. The cylinder will represent the ocean surrounding the platform. The bottom of the cylinder will be the sea floor, and the top the ocean surface.

- 1 In the **Geometry** toolbar, click  **Cylinder**.
- 2 In the **Settings** window for **Cylinder**, locate the **Size and Shape** section.
- 3 In the **Radius** text field, type 40.
- 4 In the **Height** text field, type 92.
- 5 Click  **Build Selected**.

- 6 Click the  **Wireframe Rendering** button in the **Graphics** toolbar.

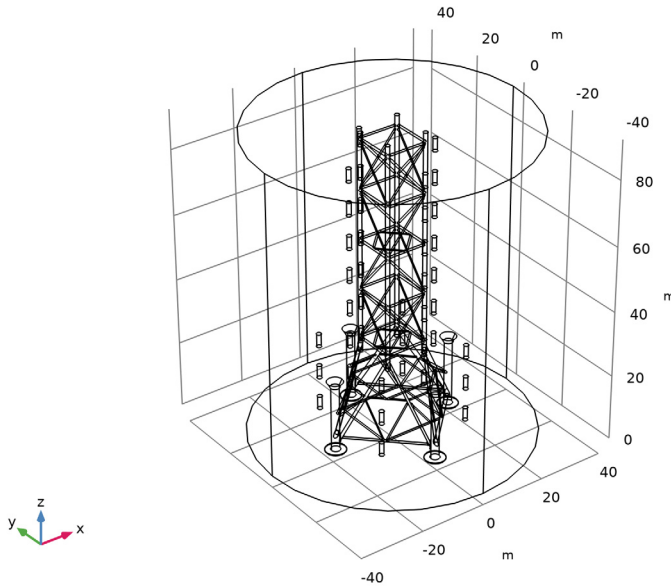



Add a second cylinder with a larger radius. This cylinder will be used to define an Infinite Element Domain, in order to define an infinite extension of the sea in the x and y directions.

Cylinder 2 (cyl2)

- 1 Right-click **Cylinder 1 (cyl1)** and choose **Duplicate**.
- 2 In the **Settings** window for **Cylinder**, locate the **Size and Shape** section.
- 3 In the **Radius** text field, type 60.
- 4 Click the  **Zoom Extents** button in the **Graphics** toolbar.

Difference 1 (dif1)

Create the final geometry as the difference between the cylinders and the imported oil platform structure.

- 1 In the **Geometry** toolbar, click  **Booleans and Partitions** and choose **Difference**.
- 2 Select the objects **cyl1** and **cyl2** only.
- 3 In the **Settings** window for **Difference**, locate the **Difference** section.
- 4 Find the **Objects to subtract** subsection. Click to select the  **Activate Selection** toggle button.

5 Use the **Select Box** toolbar button to select the imported platform geometry.

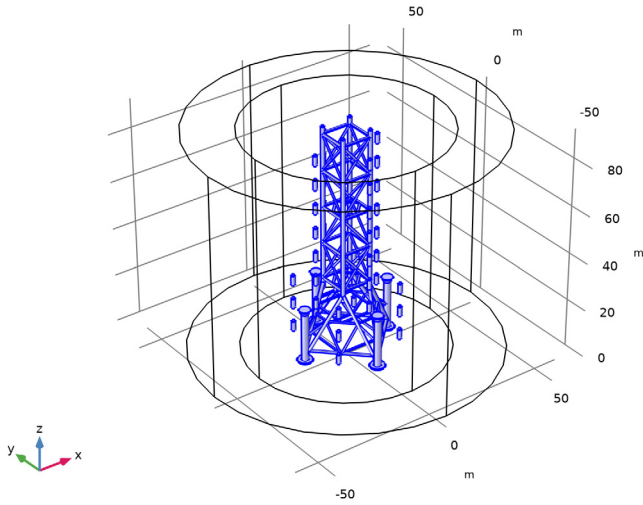

6 Click  **Build Selected.**

7 Click the  **Zoom Extents** button in the **Graphics** toolbar.

The finalized geometry should now look like that in the figure below.

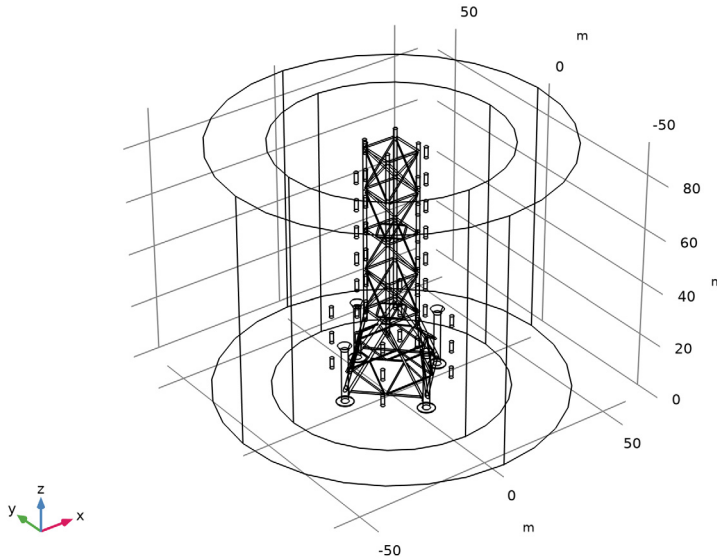

DEFINITIONS

Now set the outer cylinder to be an Infinite Element Domain, this will scale the equations of the outer cylinder to have an approximately 1000 times larger radius.

Infinite Element Domain 1 (ie1)

- 1 In the **Model Builder** window, expand the **Component 1 (comp1)>Definitions** node.
- 2 Right-click **Definitions** and choose **Infinite Element Domain**.
- 3 Select Domain 1 only.
- 4 In the **Settings** window for **Infinite Element Domain**, locate the **Geometry** section.
- 5 From the **Type** list, choose **Cylindrical**.

DEFINITIONS

Anodes

Create a selection for the anodes by using a difference between selections that were created (by enabling Create selections) by the geometry node.

- 1 In the **Definitions** toolbar, click  **Difference**.

- 2 In the **Settings** window for **Difference**, type Anodes in the **Label** text field.
- 3 Locate the **Geometric Entity Level** section. From the **Level** list, choose **Boundary**.
- 4 Locate the **Input Entities** section. Under **Selections to add**, click **+ Add**.
- 5 In the **Add** dialog box, select **Import 1** in the **Selections to add** list.
- 6 Click **OK**.
- 7 In the **Settings** window for **Difference**, locate the **Input Entities** section.
- 8 Under **Selections to subtract**, click **+ Add**.
- 9 In the **Add** dialog box, select **Object 41 (Import 1)** in the **Selections to subtract** list.
- 10 Click **OK**.

MATERIALS

Load the **Seawater** electrolyte material from the Corrosion Material Library as follows:

ADD MATERIAL

- 1 In the **Home** toolbar, click  **Add Material** to open the **Add Material** window.
- 2 Go to the **Add Material** window.
- 3 In the tree, select **Corrosion>Electrolytes>Seawater**.
- 4 Right-click and choose **Add to Component 1 (comp1)**.

The **Seawater** entry contains salinity and temperature-dependent conductivity data. The temperature will be defined later when setting up the physics. The salinity is set to a constant value of 3.5%, but may be altered on the **Seawater** node itself.

- 5 In the **Home** toolbar, click  **Add Material** to close the **Add Material** window.

MATERIALS

Seawater (mat1)

The **Seawater** node will be assigned to all domains by default.

CATHODIC PROTECTION (CP)

Set the electrolyte potential discretization to Linear to reduce computational time.

- 1 In the **Model Builder** window, under **Component 1 (comp1)** click **Cathodic Protection (cp)**.
- 2 In the **Settings** window for **Cathodic Protection**, click to expand the **Discretization** section.
- 3 From the **Electrolyte potential** list, choose **Linear**.

Electrolyte 1

On the **Electrolyte** node, the electrolyte conductivity is set to be taken from the **Materials** node by default. Proceed as follows to define the input temperature to be used for calculating the temperature-dependent conductivity:

- 1 In the **Model Builder** window, under **Component 1 (comp1)>Cathodic Protection (cp)** click **Electrolyte 1**.
- 2 In the **Settings** window for **Electrolyte**, locate the **Model Input** section.
- 3 From the T list, choose **User defined**. In the associated text field, type 10[degC].

Alternatively, the temperature can be set in the **Default Model Inputs** node, found under **Global Definitions** at the top of the model builder tree.

Electrode Surface - Anodes

Now add boundary conditions for the anodes and the steel structure.

- 1 In the **Physics** toolbar, click  **Boundaries** and choose **Electrode Surface**.
The **Electrode Surface** node is a general node for defining any electrochemically active surface. In this model we will use it to constrain the electrolyte potential at the sacrificial anode surfaces.
- 2 In the **Settings** window for **Electrode Surface**, type Electrode Surface - Anodes in the **Label** text field.
- 3 Locate the **Boundary Selection** section. From the **Selection** list, choose **Anodes**.

Electrode Reaction 1

- 1 In the **Model Builder** window, click **Electrode Reaction 1**.
- 2 In the **Settings** window for **Electrode Reaction**, locate the **Equilibrium Potential** section.
- 3 In the E_{eq} text field, type Eeq_A1.
- 4 Locate the **Electrode Kinetics** section. From the **Kinetics expression type** list, choose **Primary condition (thermodynamic equilibrium)**.

Protected Metal Surface - Steel

- 1 In the **Physics** toolbar, click  **Boundaries** and choose **Protected Metal Surface**.
The **Protected Metal Surface** node is a tailor-made node for defining a surface for the specific case where it assumed that only oxygen reduction, but no metal dissolution reactions occur. In this model we will use it to define the steel surface of the oil platform, and assume the oxygen reduction current density to be limited by a constant transport rate.

- 2 In the **Settings** window for **Protected Metal Surface**, type Protected Metal Surface - Steel in the **Label** text field.
- 3 Locate the **Boundary Selection** section. From the **Selection** list, choose **Object 41 (Import I)**.
- 4 Locate the **Oxygen Reduction Current Density** section. In the i_{O_2} text field, type i_{oxygen} .

MESH I

The physics is now complete. Modify the default mesh as follows:



- 1 In the **Model Builder** window, under **Component 1 (comp1)** click **Mesh I**.
- 2 In the **Settings** window for **Mesh**, locate the **Sequence Type** section.
- 3 From the list, choose **User-controlled mesh**.

Size

- 1 In the **Model Builder** window, under **Component 1 (comp1)>Mesh I** click **Size**.
- 2 In the **Settings** window for **Size**, locate the **Element Size** section.
- 3 Click the **Custom** button.
- 4 Locate the **Element Size Parameters** section. In the **Maximum element size** text field, type 10.
- 5 In the **Minimum element size** text field, type 0.5.
- 6 In the **Curvature factor** text field, type 0.9.
- 7 In the **Maximum element size** text field, type 15.



Add a free triangular mesh for some surfaces, and mesh it prior to the final tetrahedral mesh for the remaining geometry.

Free Triangular I

- 1 In the **Mesh** toolbar, click  **Boundary** and choose **Free Triangular**.
- 2 Right-click **Free Triangular I** and choose **Move Up**.
- 3 In the **Settings** window for **Free Triangular**, locate the **Boundary Selection** section.
- 4 Click  **Paste Selection**.
- 5 In the **Paste Selection** dialog box, type 17 19 145 147 314 316 368 370 in the **Selection** text field.
- 6 Click **OK**.



Size I

- 1 Right-click **Free Triangular I** and choose **Size**.

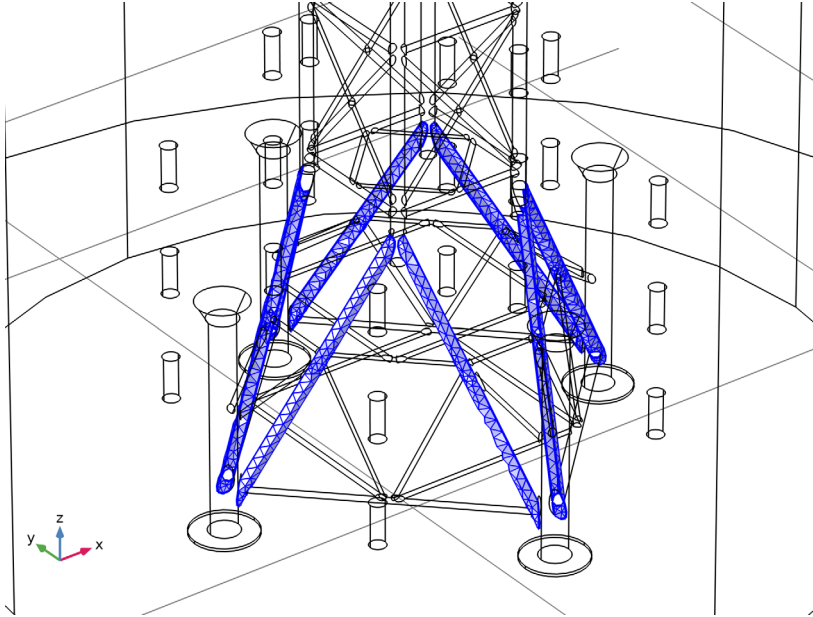
- 2 In the **Settings** window for **Size**, locate the **Element Size** section.
- 3 Click the **Custom** button.
- 4 Locate the **Element Size Parameters** section.
- 5 Select the **Minimum element size** check box. In the associated text field, type 1.08.
- 6 Click  **Build Selected**.
- 7 Locate the **Geometric Entity Selection** section. Click  **Zoom to Selection**.



Free Tetrahedral I

- 1 In the **Model Builder** window, under **Component 1 (comp1)>Mesh 1** click **Free Tetrahedral 1**.
- 2 In the **Settings** window for **Free Tetrahedral**, click  **Build All**.
- 3 Click the  **Zoom Extents** button in the **Graphics** toolbar.

STUDY 1



The problem is now ready for solving.

- 1 In the **Home** toolbar, click  **Compute**.

RESULTS

Several plots are added by default.

Electrolyte Potential (cp)

- 1 Click the  **Zoom Extents** button in the **Graphics** toolbar.
- 2 In the **Model Builder** window, under **Results** click **Electrolyte Potential (cp)**.
- 3 In the **Electrolyte Potential (cp)** toolbar, click  **Plot**.

Compare with [Figure 4](#).

Anode current densities (cp)



Modify the second default plot in order to depict the current density on the anodes as follows:

- 1 In the **Model Builder** window, under **Results** click **Electrolyte Current Density (cp)**.
- 2 In the **Settings** window for **3D Plot Group**, type Anode current densities (cp) in the **Label** text field.
- 3 Click to expand the **Title** section. From the **Title type** list, choose **Manual**.
- 4 In the **Title** text area, type Anode current densities (A/m^2).
- 5 Locate the **Plot Settings** section. Clear the **Plot dataset edges** check box.

Surface I

In the **Model Builder** window, expand the **Anode current densities (cp)** node, then click **Surface I**.

Selection I

- 1 In the **Anode current densities (cp)** toolbar, click  **Selection**.
- 2 In the **Settings** window for **Selection**, locate the **Selection** section.
- 3 From the **Selection** list, choose **Anodes**.
- 4 Click the  **Zoom Extents** button in the **Graphics** toolbar.
- 5 In the **Anode current densities (cp)** toolbar, click  **Plot**.

Compare with [Figure 7](#).

Steel potential (cp)

The third default plot depicts the electrode phase potential of the steel structure.

- 1 In the **Model Builder** window, under **Results** click **Electrode Potential vs. Adjacent Reference (cp)**.
- 2 In the **Settings** window for **3D Plot Group**, type Steel potential (cp) in the **Label** text field.
- 3 Locate the **Title** section. From the **Title type** list, choose **Manual**.
- 4 In the **Title** text area, type Steel potential vs. Ag/AgCl (V).

- 5 Locate the **Plot Settings** section. Clear the **Plot dataset edges** check box.



Streamline 1

- 1 In the **Model Builder** window, expand the **Steel potential (cp)** node.
- 2 Right-click **Streamline 1** and choose **Disable**.

Surface 1

In the **Model Builder** window, click **Surface 1**.

Selection 1

- 1 In the **Steel potential (cp)** toolbar, click  **Selection**.
- 2 In the **Settings** window for **Selection**, locate the **Selection** section.
- 3 From the **Selection** list, choose **Object 41 (Import 1)**.
- 4 Click the  **Zoom Extents** button in the **Graphics** toolbar.
- 5 In the **Steel potential (cp)** toolbar, click  **Plot**.

The plot should look like that in [Figure 5](#).



Steel potential (cp)

Create a close-up of the steel potential plot as follows:

Steel potential (cp) 1



- 1 In the **Model Builder** window, right-click **Steel potential (cp)** and choose **Duplicate**.
- 2 Expand the **Steel potential (cp) 1** node.

Selection 1

- 1 In the **Model Builder** window, expand the **Results>Steel potential (cp) 1>Surface 1** node, then click **Selection 1**.
- 2 In the **Settings** window for **Selection**, locate the **Selection** section.
- 3 From the **Selection** list, choose **Manual**.
- 4 Click  **Clear Selection**.
- 5 Click  **Paste Selection**.
- 6 In the **Paste Selection** dialog box, type 212-214, 218-220, 223-224 in the **Selection** text field.
- 7 Click **OK**.

Steel potential, close-up (cp)

- 1 In the **Model Builder** window, under **Results** click **Steel potential (cp) 1**.

- 2 In the **Settings** window for **3D Plot Group**, type Steel potential, close-up (cp) in the **Label** text field.
- 3 Click the  **Zoom Extents** button in the **Graphics** toolbar.
- 4 In the **Steel potential, close-up (cp)** toolbar, click  **Plot**.
Compare the resulting plot with that in [Figure 6](#).

