



# Monopile with Dissolving Sacrificial Anodes

## *Introduction*

---

A monopile foundation is a large-diameter structural element that can be used to support, for instance, an off-shore windmill.

This application exemplifies how the cathodic protection of a monopile decreases over time as the sacrificial anodes dissolve. The example includes secondary current distribution electrode kinetics on the protected steel structure, defining simultaneous metal dissolution and oxygen reduction (mixed potential).

By including a lumped resistance in the model between the upper structure and the lower steel pipe foundation, it is seen that the corrosion protection of the lower part is worsened.

## *Model Definition*

---

The monopile geometry consists of an upper part (“the transition piece”) with a coated steel surface and a lower uncoated steel pipe. Both parts are based on slightly conical cylinders, and the upper part also features a smaller ladder and a platform. Around the monopile, arrays of sacrificial anodes are placed. The surrounding ocean (salt water) and sea bed (mud) are defined as cylinders. Symmetry is used to halve the problem size. The geometry is shown in [Figure 1](#).

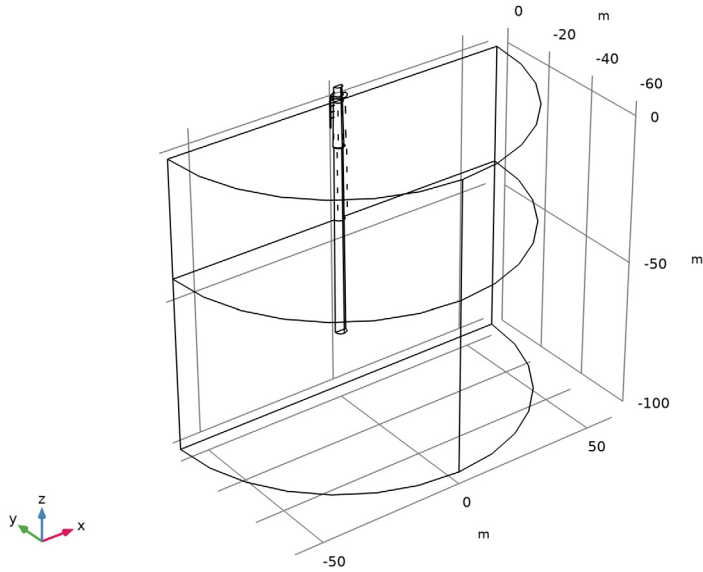

*Figure 1: Model geometry.*

The monopile steel surface is defined using Electrode Surfaces nodes, including simultaneous oxygen reduction and steel oxidation. Tafel kinetics is used for defining the steel oxidation reaction, and different kinetic parameters are used for the coated transition piece and the uncoated lower pipe. The oxygen reduction kinetics is defined using a limiting current density, which has a lower value on the mud-covered surface.

The sacrificial anodes are drawn as edges in the geometry and modeled using Sacrificial Edge Anode nodes. As the anodes are dissolved the radius of the anodes are lowered, and when the terminal radius is reached the anodes are shut off.

The model is solved using a Time-dependent study for a time period of twelve years. Two cases are investigated. In the first case the whole monopile is grounded. In the second case the transition piece is grounded and the lower pipe is assumed to be connected to the transition piece through a lumped resistance.

## Results and Discussion

Figure 2 shows the steel surface potential at the beginning of the simulation. A higher potential indicates a more oxidative (corrosive) environment. The mud-covered part of the monopile is exposed to the highest potentials.

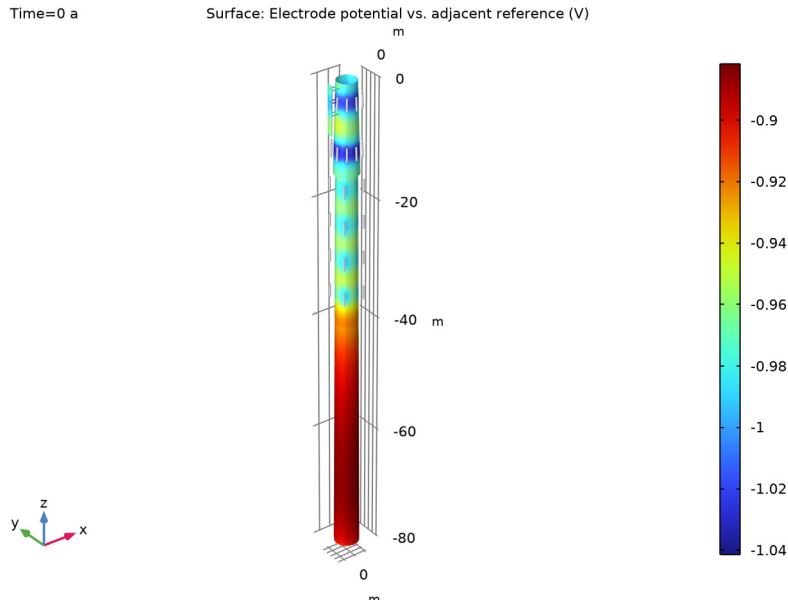
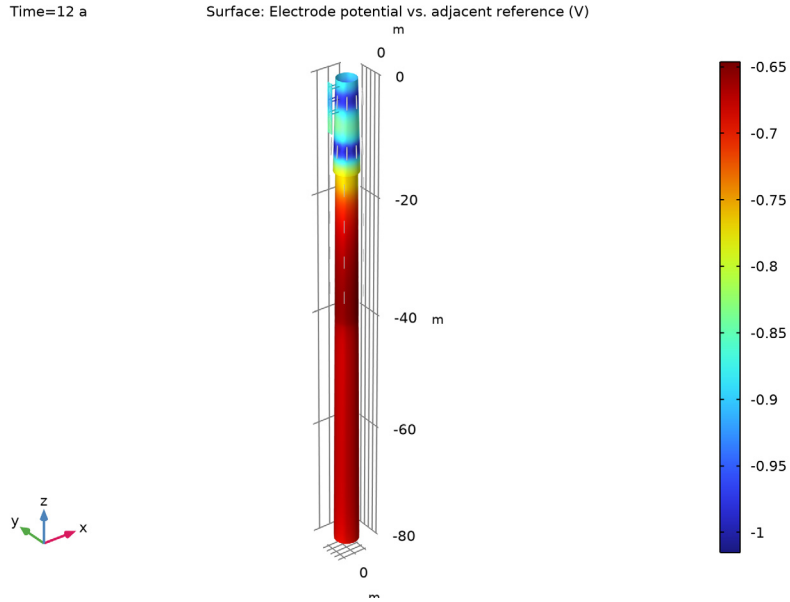
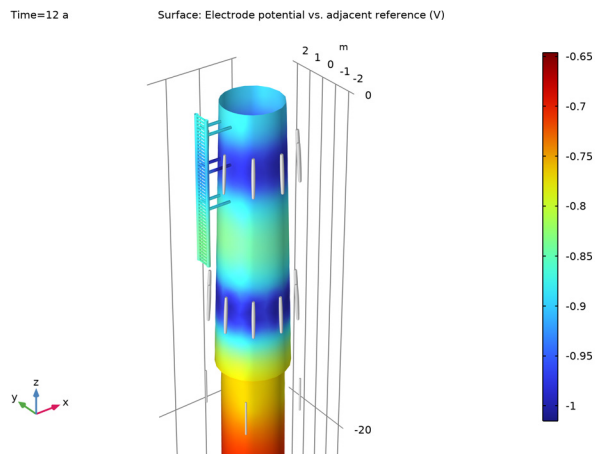

Figure 2: Steel surface potential at the beginning of the simulation.

Figure 3 and the close-up in Figure 4 depicts the potential at the end of the simulation. Compared to the situation at  $t = 0$ , the potentials are generally higher, especially for the lower part. Figure 4 also shows that the anodes facing the lower part of the monopile have been consumed at a higher rate.



*Figure 3: Steel surface potential at the end of the simulation.*



*Figure 4: Steel surface potential at the end of the simulation (close-up).*

Figure 5 and Figure 6 show the steel oxidation current density (that is, the corrosion rate), at the beginning and end of the simulation, respectively. The corrosion rate increases approximately three orders of magnitudes as a result of the dissolution of the anodes.

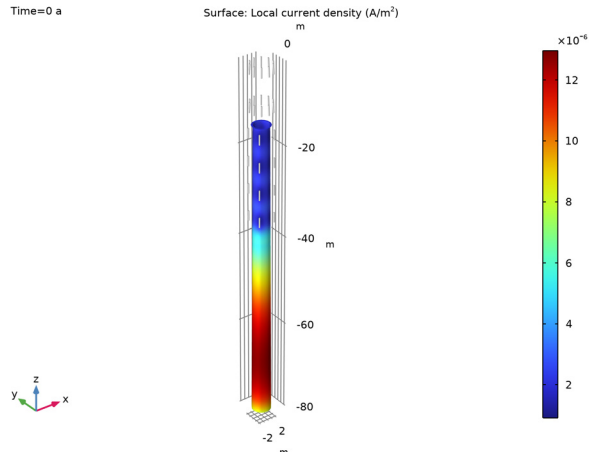

Figure 5: Steel oxidation current density at the beginning of the simulation.

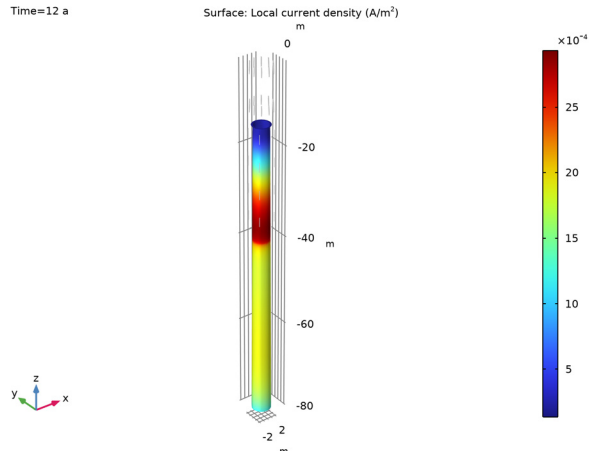
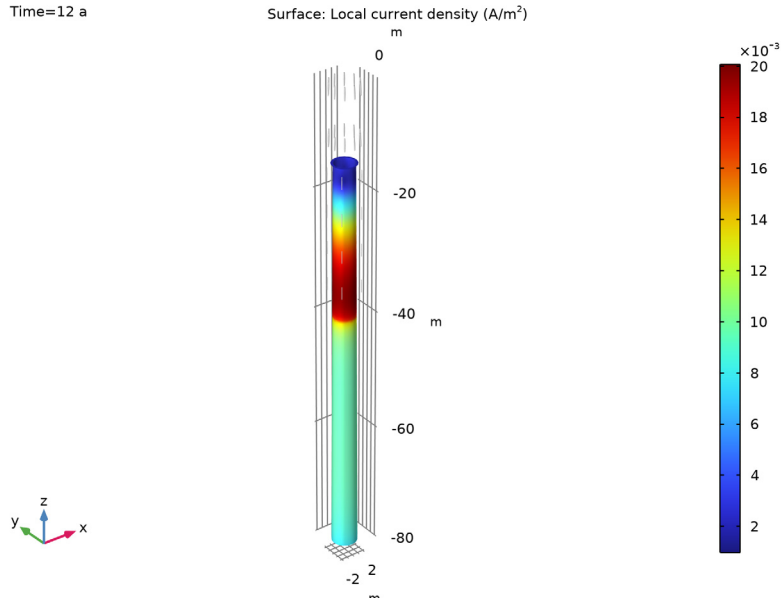

Figure 6: Steel oxidation current density at the end of the simulation.



*Figure 7: Steel oxidation current density at the end of the simulation when introducing a lumped resistance between the transition piece and the lower part of the monopile.*

Figure 7 shows the steel oxidation current densities at the end of the simulation for the second case when a lumped resistance between the lower and upper part of the monopile has been introduced. The corrosion rate for the lower part is generally higher compared to Figure 6.

---

**Application Library path:** Corrosion\_Module/Cathodic\_Protection/monopile

---

### *Modeling Instructions*



---

From the **File** menu, choose **New**.

#### **NEW**

In the **New** window, click  **Model Wizard**.

## MODEL WIZARD

- 1 In the **Model Wizard** window, click  **3D**.
- 2 In the **Select Physics** tree, select **Electrochemistry>Cathodic Protection (cp)**.
- 3 Click **Add**.
- 4 Click  **Study**.
- 5 In the **Select Study** tree, select **General Studies>Time Dependent**.
- 6 Click  **Done**.



## GLOBAL DEFINITIONS

### *Parameters 1*

- 1 In the **Model Builder** window, under **Global Definitions** click **Parameters 1**.
- 2 In the **Settings** window for **Parameters**, locate the **Parameters** section.
- 3 Click  **Load from File**.
- 4 Browse to the model's Application Libraries folder and double-click the file `monopile_parameters.txt`.

## GEOMETRY 1

The model geometry is available as a parameterized geometry sequence in a separate MPH-file. If you want to build it from scratch, follow the instructions in the section [Appendix — Geometry Modeling Instructions](#). Otherwise load it from file with the following steps.

- 1 In the **Geometry** toolbar, click **Insert Sequence** and choose **Insert Sequence**.
- 2 Browse to the model's Application Libraries folder and double-click the file `monopile_geom_sequence.mph`.
- 3 In the **Geometry** toolbar, click  **Build All**.
- 4 Click the  **Zoom Extents** button in the **Graphics** toolbar.



- 5 Click the  **Wireframe Rendering** button in the **Graphics** toolbar.

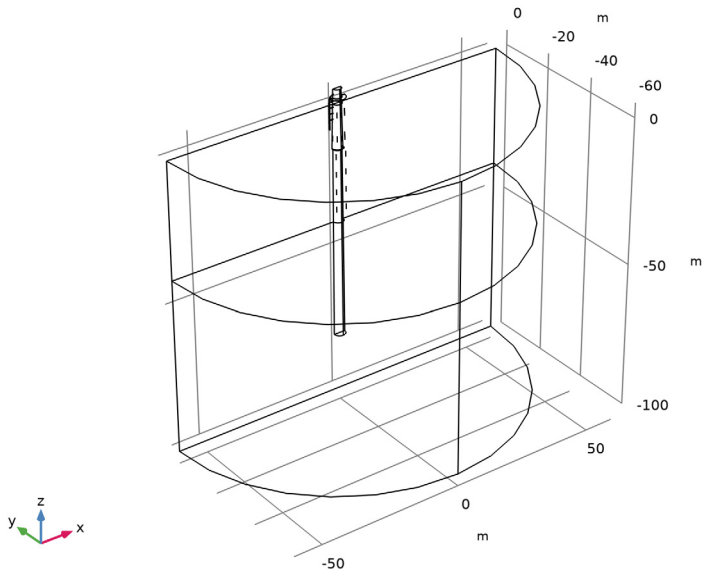

## MATERIALS

Load the **Seawater** electrolyte material from the Corrosion Material Library as follows:

### ADD MATERIAL

- 1 In the **Home** toolbar, click  **Add Material** to open the **Add Material** window.
- 2 Go to the **Add Material** window.
- 3 In the tree, select **Corrosion>Electrolytes>Seawater**.
- 4 Right-click and choose **Add to Component 1 (comp1)**.

The **Seawater** entry contains salinity and temperature-dependent conductivity data. The temperature will be taken from the **Default Model Inputs** that you will define later. The salinity is set to a constant value of 3.5%, but may be altered on the **Seawater** node itself.

- 5 In the **Home** toolbar, click  **Add Material** to close the **Add Material** window.

## MATERIALS

*Seawater (mat1)*

- 1 In the **Settings** window for **Material**, locate the **Geometric Entity Selection** section.
- 2 Click  **Clear Selection**.

3 Select Domain 2 only.

#### *Mud*

- 1 In the **Model Builder** window, right-click **Materials** and choose **Blank Material**.
- 2 In the **Settings** window for **Material**, type Mud in the **Label** text field.
- 3 Select Domain 1 only.
- 4 Locate the **Material Contents** section. In the table, enter the following settings:

Property	Variable	Value	Unit	Property group
Electrolyte conductivity	sigma_iso ; sigma <sub>lii</sub> = sigma <sub>iso</sub> , sigma <sub>lij</sub> = 0	sigma_mud	S/m	Electrolyte conductivity

## GLOBAL DEFINITIONS

### *Default Model Inputs*

Set up the temperature value used in the model.

- 1 In the **Model Builder** window, under **Global Definitions** click **Default Model Inputs**.
- 2 In the **Settings** window for **Default Model Inputs**, locate the **Browse Model Inputs** section.
- 3 In the tree, select **General>Temperature (K) - minput.T**.
- 4 Find the **Expression for remaining selection** subsection. In the **Temperature** text field, type T.

## DEFINITIONS

### *Top*

- 1 In the **Definitions** toolbar, click  **Cylinder**.
- 2 In the **Settings** window for **Cylinder**, type Top in the **Label** text field.
- 3 Locate the **Geometric Entity Level** section. From the **Level** list, choose **Boundary**.
- 4 Locate the **Size and Shape** section. In the **Outer radius** text field, type 10.
- 5 In the **Top distance** text field, type 0.1.
- 6 In the **Bottom distance** text field, type -20.1.
- 7 Locate the **Output Entities** section. From the **Include entity if** list, choose **Entity inside cylinder**.

### *Middle*



- 1 Right-click **Top** and choose **Duplicate**.

- 2 In the **Settings** window for **Cylinder**, type **Middle** in the **Label** text field.
- 3 Locate the **Size and Shape** section. In the **Top distance** text field, type 0.
- 4 In the **Bottom distance** text field, type -40.
- 5 Locate the **Position** section. In the **z** text field, type -15.

#### *Bottom*

- 1 Right-click **Middle** and choose **Duplicate**.
- 2 In the **Settings** window for **Cylinder**, type **Bottom** in the **Label** text field.
- 3 Locate the **Size and Shape** section. In the **Bottom distance** text field, type -60.
- 4 Locate the **Position** section. In the **z** text field, type -30.

#### *Middle and Bottom*

- 1 In the **Definitions** toolbar, click  **Union**.
- 2 In the **Settings** window for **Union**, locate the **Geometric Entity Level** section.
- 3 From the **Level** list, choose **Boundary**.
- 4 In the **Label** text field, type **Middle** and **Bottom**.
- 5 Locate the **Input Entities** section. Under **Selections to add**, click  **Add**.
- 6 In the **Add** dialog box, in the **Selections to add** list, choose **Middle** and **Bottom**.
- 7 Click **OK**.

### **CATHODIC PROTECTION (CP)**

- 1 In the **Model Builder** window, under **Component 1 (comp1)** click **Cathodic Protection (cp)**.
- 2 In the **Settings** window for **Cathodic Protection**, locate the **Domain Selection** section.
- 3 In the list, select **3**.
- 4 Click  **Remove from Selection**.
- 5 Select Domains 1 and 2 only.

#### *Protected Metal Surface - Coated Steel*

- 1 In the **Physics** toolbar, click  **Boundaries** and choose **Protected Metal Surface**.
- 2 In the **Settings** window for **Protected Metal Surface**, type **Protected Metal Surface - Coated Steel** in the **Label** text field.
- 3 Locate the **Boundary Selection** section. From the **Selection** list, choose **Top**.
- 4 Locate the **Oxygen Reduction Current Density** section. In the  $i_{O_2}$  text field, type **ilim\_02**.

#### *Electrode Surface - Uncoated Steel*

- 1 In the **Physics** toolbar, click  **Boundaries** and choose **Electrode Surface**.

- 2 In the **Settings** window for **Electrode Surface**, type Electrode Surface - Uncoated Steel in the **Label** text field.
- 3 Locate the **Boundary Selection** section. From the **Selection** list, choose **Middle and Bottom**.



#### *Electrode Reaction 1 - Steel Oxidation*

- 1 In the **Model Builder** window, click **Electrode Reaction 1**.
- 2 In the **Settings** window for **Electrode Reaction**, type Electrode Reaction 1 - Steel Oxidation in the **Label** text field.
- 3 Locate the **Equilibrium Potential** section. In the  $E_{eq}$  text field, type  $E_{eq\_Fe}$ .
- 4 Locate the **Electrode Kinetics** section. From the **Kinetics expression type** list, choose **Anodic Tafel equation**.
- 5 In the  $i_0$  text field, type  $i_{0\_Fe}$ .
- 6 In the  $A_a$  text field, type  $A_{\_Fe}$ .

#### *Electrode Surface - Uncoated Steel*

In the **Model Builder** window, click **Electrode Surface - Uncoated Steel**.

#### *Electrode Reaction 2 - Oxygen Reduction (Sea)*

- 1 In the **Physics** toolbar, click  **Attributes** and choose **Electrode Reaction**.
- 2 In the **Settings** window for **Electrode Reaction**, type Electrode Reaction 2 - Oxygen Reduction (Sea) in the **Label** text field.
- 3 Locate the **Boundary Selection** section. Click  **Clear Selection**.
- 4 From the **Selection** list, choose **Middle**.
- 5 Locate the **Electrode Kinetics** section. From the  $i_{loc,expr}$  list, choose **User defined**. In the associated text field, type  $i_{lim\_O2}$ .

#### *Electrode Reaction 3 - Oxygen Reduction (Mud)*

- 1 Right-click **Electrode Reaction 2 - Oxygen Reduction (Sea)** and choose **Duplicate**.
- 2 In the **Settings** window for **Electrode Reaction**, type Electrode Reaction 3 - Oxygen Reduction (Mud) in the **Label** text field.
- 3 Locate the **Boundary Selection** section. From the **Selection** list, choose **Bottom**.
- 4 Locate the **Electrode Kinetics** section. In the  $i_{loc,expr}$  text field, type  $i_{lim\_O2\_mud}$ .

#### *Sacrificial Edge Anode 1*

- 1 In the **Physics** toolbar, click  **Edges** and choose **Sacrificial Edge Anode**.
- 2 In the **Settings** window for **Sacrificial Edge Anode**, locate the **Edge Selection** section.

- 3 From the **Selection** list, choose **Anodes**.
- 4 Locate the **Sacrificial Anode Properties** section. In the  $Q_0$  text field, type AnodeCap.
- 5 In the  $r_0$  text field, type R0.
- 6 In the  $r_{\text{end}}$  text field, type Rf.

#### *Electrode Reaction 1*

- 1 In the **Model Builder** window, click **Electrode Reaction 1**.
- 2 In the **Settings** window for **Electrode Reaction**, locate the **Equilibrium Potential** section.
- 3 In the  $E_{\text{eq}}$  text field, type Eeq\_AlZn.

#### *Symmetry 1*

- 1 In the **Physics** toolbar, click  **Boundaries** and choose **Symmetry**.
- 2 Select Boundaries 2, 4, and 266 only.

#### *Initial Values 1*

- 1 In the **Model Builder** window, click **Initial Values 1**.
- 2 In the **Settings** window for **Initial Values**, locate the **Initial Values** section.
- 3 In the *phil* text field, type -Eeq\_AlZn.

### **MESH 1**

#### *Size*

- 1 In the **Model Builder** window, under **Component 1 (comp1)** right-click **Mesh 1** and choose **Edit Physics-Induced Sequence**.
- 2 In the **Settings** window for **Size**, locate the **Element Size** section.
- 3 Click the **Custom** button.
- 4 Locate the **Element Size Parameters** section. In the **Minimum element size** text field, type 0.05.
- 5 In the **Curvature factor** text field, type 0.4.

#### *Size 1*

- 1 In the **Model Builder** window, right-click **Free Tetrahedral 1** and choose **Size**.
- 2 In the **Settings** window for **Size**, locate the **Geometric Entity Selection** section.
- 3 From the **Geometric entity level** list, choose **Edge**.
- 4 From the **Selection** list, choose **Anodes**.
- 5 Locate the **Element Size** section. From the **Predefined** list, choose **Extremely fine**.
- 6 Click the **Custom** button.

- 7 Locate the **Element Size Parameters** section.
- 8 Select the **Maximum element size** check box. In the associated text field, type 0.1.
- 9 Click  **Build All**.

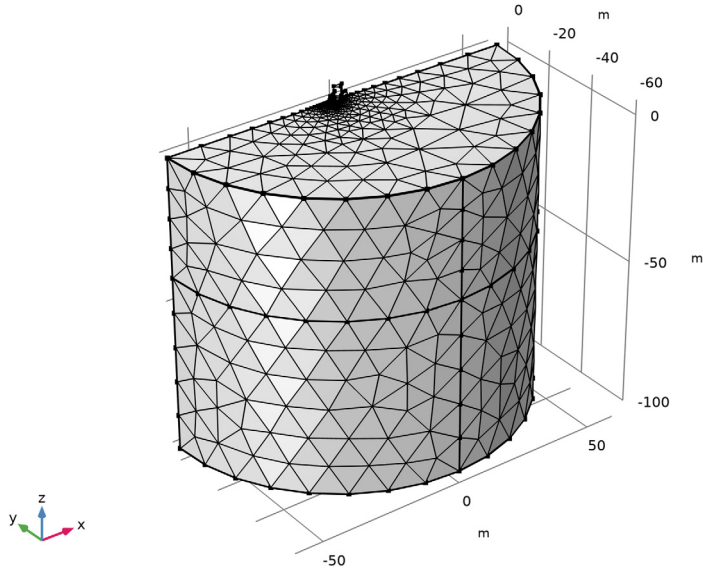

## STUDY I

### *Step 1: Time Dependent*

- 1 In the **Model Builder** window, under **Study I** click **Step 1: Time Dependent**.
- 2 In the **Settings** window for **Time Dependent**, locate the **Study Settings** section.
- 3 From the **Time unit** list, choose **a**.
- 4 In the **Output times** text field, type range(0,1,12).
- 5 In the **Model Builder** window, click **Study I**.
- 6 In the **Settings** window for **Study**, locate the **Study Settings** section.
- 7 Clear the **Generate default plots** check box.
- 8 In the **Home** toolbar, click  **Compute**.

## RESULTS

### *Mirror 3D I*

- 1 In the **Model Builder** window, expand the **Results** node.
- 2 Right-click **Results>Datasets** and choose **More 3D Datasets>Mirror 3D**.
- 3 In the **Settings** window for **Mirror 3D**, locate the **Plane Data** section.
- 4 From the **Plane** list, choose **ZX-planes**.

### *Steel Electrode Potential*

- 1 In the **Results** toolbar, click  **3D Plot Group**.
- 2 In the **Settings** window for **3D Plot Group**, type Steel Electrode Potential in the **Label** text field.
- 3 Locate the **Data** section. From the **Dataset** list, choose **Mirror 3D I**.
- 4 Locate the **Plot Settings** section. Clear the **Plot dataset edges** check box.

### *Surface I*

- 1 Right-click **Steel Electrode Potential** and choose **Surface**.
- 2 In the **Settings** window for **Surface**, click **Replace Expression** in the upper-right corner of the **Expression** section. From the menu, choose **Component 1 (comp1)>Cathodic Protection>cp.Evsref - Electrode potential vs. adjacent reference - V**.
- 3 In the **Steel Electrode Potential** toolbar, click  **Plot**.

### *Line I*

- 1 In the **Model Builder** window, right-click **Steel Electrode Potential** and choose **Line**.
- 2 In the **Settings** window for **Line**, locate the **Expression** section.
- 3 In the **Expression** text field, type 1.
- 4 Click to expand the **Title** section. From the **Title type** list, choose **None**.
- 5 Locate the **Coloring and Style** section. From the **Line type** list, choose **Tube**.
- 6 In the **Tube radius expression** text field, type cp.redge.
- 7 Select the **Radius scale factor** check box.
- 8 From the **Coloring** list, choose **Uniform**.
- 9 From the **Color** list, choose **Gray**.

### *Steel Electrode Potential*

- 1 Click the  **Zoom Extents** button in the **Graphics** toolbar.
- 2 In the **Model Builder** window, click **Steel Electrode Potential**.

**3** In the **Settings** window for **3D Plot Group**, locate the **Data** section.

**4** From the **Time (a)** list, choose **0**.

**5** In the **Steel Electrode Potential** toolbar, click  **Plot**.

The Electrode Potential vs. Adjacent reference at time  $t = 0$  a should look like [Figure 2](#).

**6** From the **Time (a)** list, choose **12**.

**7** In the **Steel Electrode Potential** toolbar, click  **Plot**.

The Electrode Potential vs. Adjacent reference at time  $t = 12$  a should look like [Figure 3](#).

#### *Iron Dissolution Current Density*

**1** Right-click **Steel Electrode Potential** and choose **Duplicate**.

**2** In the **Settings** window for **3D Plot Group**, type Iron Dissolution Current Density in the **Label** text field.

#### *Surface 1*

**1** In the **Model Builder** window, expand the **Iron Dissolution Current Density** node, then click **Surface 1**.

**2** In the **Settings** window for **Surface**, click **Replace Expression** in the upper-right corner of the **Expression** section. From the menu, choose **Component 1 (comp1) > Cathodic Protection > Electrode kinetics > cp.iloc\_er1 - Local current density - A/m<sup>2</sup>**.

**3** In the **Iron Dissolution Current Density** toolbar, click  **Plot**.

**4** Click the  **Zoom Extents** button in the **Graphics** toolbar.

#### *Iron Dissolution Current Density*

**1** In the **Model Builder** window, click **Iron Dissolution Current Density**.

**2** In the **Settings** window for **3D Plot Group**, locate the **Data** section.

**3** From the **Time (a)** list, choose **0**.

**4** In the **Iron Dissolution Current Density** toolbar, click  **Plot**.

The local current density at time  $t = 0$  a should look like [Figure 5](#).

**5** From the **Time (a)** list, choose **12**.

**6** In the **Iron Dissolution Current Density** toolbar, click  **Plot**.

The local current density at time  $t = 12$  a should look like [Figure 6](#).



## CATHODIC PROTECTION (CP)

### *Electrode Surface - Uncoated Steel*

- 1 In the **Model Builder** window, under **Component 1 (comp1)**>**Cathodic Protection (cp)** click **Electrode Surface - Uncoated Steel**.
- 2 In the **Settings** window for **Electrode Surface**, locate the **Electrode Phase Potential Condition** section.
- 3 From the **Electrode phase potential condition** list, choose **External short**.
- 4 In the  $R$  text field, type  $R_{Tp}$ .

## STUDY 1

In the **Home** toolbar, click  **Compute**.

## RESULTS

### *Iron Dissolution Current Density*

- 1 In the **Model Builder** window, under **Results** click **Iron Dissolution Current Density**.
- 2 In the **Iron Dissolution Current Density** toolbar, click  **Plot**.

The local current density after introducing external short at time  $t = 12$  a should look like [Figure 7](#).

## *Appendix — Geometry Modeling Instructions*



---

From the **File** menu, choose **New**.

## NEW

In the **New** window, click  **Model Wizard**.



## MODEL WIZARD

- 1 In the **Model Wizard** window, click  **3D**.
- 2 Click  **Done**.



## GEOMETRY 1

### *Cone 1 (cone1)*

- 1 In the **Geometry** toolbar, click  **Cone**.
- 2 In the **Settings** window for **Cone**, locate the **Size and Shape** section.
- 3 In the **Bottom radius** text field, type 2.

- 4 In the **Height** text field, type 80.
- 5 In the **Top radius** text field, type 1.6.
- 6 Locate the **Position** section. In the **z** text field, type -80.
- 7 Click  **Build Selected**.
- 8 Click the  **Wireframe Rendering** button in the **Graphics** toolbar.

#### *Cone 2 (cone2)*

- 1 In the **Geometry** toolbar, click  **Cone**.
- 2 In the **Settings** window for **Cone**, locate the **Size and Shape** section.
- 3 In the **Bottom radius** text field, type 2.
- 4 In the **Height** text field, type 20.
- 5 In the **Top radius** text field, type 1.5.
- 6 Locate the **Position** section. In the **z** text field, type -15.
- 7 Click  **Build Selected**.

#### *Work Plane 1 (wp1)*

- 1 In the **Geometry** toolbar, click  **Work Plane**.
- 2 In the **Settings** window for **Work Plane**, locate the **Plane Definition** section.
- 3 From the **Plane** list, choose **xz-plane**.
- 4 In the **y-coordinate** text field, type -0.4.
- 5 Click to expand the **Local Coordinate System** section. Click to collapse the **Local Coordinate System** section.



#### *Work Plane 1 (wp1)>Plane Geometry*

In the **Model Builder** window, click **Plane Geometry**.

#### *Work Plane 1 (wp1)>Quadratic Bézier 1 (qb1)*

- 1 In the **Work Plane** toolbar, click  **More Primitives** and choose **Quadratic Bézier**.
- 2 In the **Settings** window for **Quadratic Bézier**, locate the **Control Points** section.
- 3 In row **1**, set **xw** to 1.1.
- 4 In row **1**, set **yw** to 3.5.
- 5 In row **2**, set **xw** to 3.
- 6 In row **2**, set **yw** to 3.5.
- 7 In row **3**, set **xw** to 3.
- 8 In row **3**, set **yw** to 2.

*Work Plane 1 (wp1)>Line Segment 1 (ls1)*

- 1 In the **Work Plane** toolbar, click  **More Primitives** and choose **Line Segment**.
- 2 In the **Settings** window for **Line Segment**, locate the **Starting Point** section.
- 3 From the **Specify** list, choose **Coordinates**.
- 4 Locate the **Endpoint** section. From the **Specify** list, choose **Coordinates**.
- 5 Locate the **Starting Point** section. In the **xw** text field, type 3.
- 6 In the **yw** text field, type 2.
- 7 Locate the **Endpoint** section. In the **xw** text field, type 3.
- 8 In the **yw** text field, type -8.
- 9 In the **Work Plane** toolbar, click  **Build All**.
- 10 Click the  **Zoom Extents** button in the **Graphics** toolbar.



*Work Plane 2 (wp2)*

- 1 In the **Model Builder** window, right-click **Geometry 1** and choose **Work Plane**.
- 2 In the **Settings** window for **Work Plane**, locate the **Plane Definition** section.
- 3 In the **z-coordinate** text field, type -8.

*Work Plane 2 (wp2)>Plane Geometry*

In the **Model Builder** window, click **Plane Geometry**.

*Work Plane 2 (wp2)>Circle 1 (c1)*



- 1 In the **Work Plane** toolbar, click  **Circle**.
- 2 In the **Settings** window for **Circle**, locate the **Size and Shape** section.
- 3 In the **Radius** text field, type 0.1.
- 4 Locate the **Position** section. In the **xw** text field, type 3.
- 5 In the **yw** text field, type -0.4.
- 6 Click  **Build Selected**.

*Sweep 1 (sw1)*

- 1 In the **Model Builder** window, right-click **Geometry 1** and choose **Sweep**.
- 2 In the **Home** toolbar, click  **Windows** and choose **Selection List**.



**SELECTION LIST**

- 1 Go to the **Selection List** window.
- 2 In the tree, select **wp2>1**.
- 3 Click **Add to Active Selection for Sweep 1 (sw1)** in the window toolbar.



- 4 In the **Model Builder** window, click **Sweep 1 (sw1)**.
- 5 In the **Settings** window for **Sweep**, locate the **Spine Curve** section.
- 6 Find the **Edges to follow** subsection. Click to select the  **Activate Selection** toggle button.
- 7 Go to the **Selection List** window.
- 8 In the tree, select **wpl>1** and **wpl>2**.
- 9 Click **Add to Active Selection for Sweep 1 (sw1)** in the window toolbar.
- 10 In the **Settings** window for **Sweep**, locate the **Spine Curve** section.
- 11 Select the **Reverse direction** check box.
- 12 Locate the **Keep Input** section. Clear the **Keep input objects** check box.
- 13 Click  **Build Selected**.

## GEOMETRY 1

### *Copy 1 (copy1)*

- 1 In the **Geometry** toolbar, click  **Transforms** and choose **Copy**.
- 2 Select the object **sw1** only.
- 3 In the **Settings** window for **Copy**, locate the **Displacement** section.
- 4 In the **y** text field, type 0.8.
- 5 Click  **Build Selected**.

### *Cylinder 1 (cyl1)*

- 1 In the **Geometry** toolbar, click  **Cylinder**.
- 2 In the **Settings** window for **Cylinder**, locate the **Size and Shape** section.
- 3 In the **Radius** text field, type 2.8.
- 4 In the **Height** text field, type 0.1.
- 5 Locate the **Position** section. In the **z** text field, type 2.
- 6 Click  **Build Selected**.

### *Block 1 (blk1)*

- 1 In the **Geometry** toolbar, click  **Block**.
- 2 In the **Settings** window for **Block**, locate the **Size and Shape** section.
- 3 In the **Width** text field, type 0.1.
- 4 In the **Depth** text field, type 0.8.
- 5 In the **Height** text field, type 0.05.

- 6 Locate the **Position** section. In the **x** text field, type 2.95.
- 7 In the **y** text field, type -0.4.
- 8 In the **z** text field, type -8.
- 9 Click  **Build Selected**.

*Array 1 (arr1)*

In the **Geometry** toolbar, click  **Transforms** and choose **Array**.

#### SELECTION LIST

- 1 Go to the **Selection List** window.
- 2 In the tree, select **blk1 (solid)**.
- 3 Click **Add to Active Selection for Array 1 (arr1)** in the window toolbar.
- 4 In the **Settings** window for **Array**, locate the **Size** section.
- 5 In the **z size** text field, type 50.
- 6 Locate the **Displacement** section. In the **z** text field, type 0.18.
- 7 Click  **Build Selected**.

#### GEOMETRY I



*Work Plane 3 (wp3)*

- 1 In the **Geometry** toolbar, click  **Work Plane**.
- 2 In the **Settings** window for **Work Plane**, locate the **Plane Definition** section.
- 3 From the **Plane** list, choose **yz-plane**.
- 4 In the **x-coordinate** text field, type 3.

*Work Plane 3 (wp3)>Plane Geometry*

In the **Model Builder** window, click **Plane Geometry**.



*Work Plane 3 (wp3)>Circle 1 (c1)*

- 1 In the **Work Plane** toolbar, click  **Circle**.
- 2 In the **Settings** window for **Circle**, locate the **Size and Shape** section.
- 3 In the **Radius** text field, type 0.08.
- 4 Locate the **Position** section. In the **xw** text field, type -0.4.
- 5 In the **yw** text field, type -7.8.
- 6 Click  **Build Selected**.

*Work Plane 3 (wp3)>Array 1 (arr1)*

In the **Work Plane** toolbar, click  **Transforms** and choose **Array**.

#### **SELECTION LIST**

- 1 Go to the **Selection List** window.
- 2 In the tree, select **c1 (solid)**.
- 3 Click **Add to Active Selection for Array 1 (arr1)** in the window toolbar.
- 4 In the **Settings** window for **Array**, locate the **Size** section.
- 5 In the **xw size** text field, type 2.
- 6 In the **yw size** text field, type 4.
- 7 Locate the **Displacement** section. In the **xw** text field, type 0.8.
- 8 In the **yw** text field, type 2.
- 9 Click  **Build Selected**.
- 10 Click the  **Zoom Extents** button in the **Graphics** toolbar.

#### **GEOMETRY I**

*Extrude 1 (ext1)*

- 1 In the **Model Builder** window, under **Component 1 (comp1)** right-click **Geometry 1** and choose **Extrude**.
- 2 In the **Settings** window for **Extrude**, locate the **Distances** section.
- 3 In the table, enter the following settings:

<b>Distances (m)</b>
3

- 4 Select the **Reverse direction** check box.
- 5 Click  **Build Selected**.

*Move 1 (mov1)*

In the **Geometry** toolbar, click  **Transforms** and choose **Move**.

#### **SELECTION LIST**

- 1 Go to the **Selection List** window.
- 2 In the tree, select **ext1 (solid)**.
- 3 Click **Add to Active Selection for Move 1 (mov1)** in the window toolbar.
- 4 In the **Settings** window for **Move**, locate the **Displacement** section.

5 In the **z** text field, type 3.

6 Click  **Build Selected**.

## GEOMETRY I

### *Union I (uni1)*

1 In the **Geometry** toolbar, click  **Booleans and Partitions** and choose **Union**.

2 In the **Settings** window for **Union**, locate the **Union** section.

3 Clear the **Keep interior boundaries** check box.

## SELECTION LIST

1 Go to the **Selection List** window.

2 In the tree, select **cone2 (solid)**, **swel (solid)**, **copy1 (solid)**, **cyl1 (solid)**, **Array I>arr1(1,1,1) (solid)**, **Array I>arr1(1,1,2) (solid)**, **Array I>arr1(1,1,3) (solid)**, **Array I>arr1(1,1,4) (solid)**, **Array I>arr1(1,1,5) (solid)**, **Array I>arr1(1,1,6) (solid)**, **Array I>arr1(1,1,7) (solid)**, **Array I>arr1(1,1,8) (solid)**, **Array I>arr1(1,1,9) (solid)**, **Array I>arr1(1,1,10) (solid)**, **Array I>arr1(1,1,11) (solid)**, **Array I>arr1(1,1,12) (solid)**, **Array I>arr1(1,1,13) (solid)**, **Array I>arr1(1,1,14) (solid)**, **Array I>arr1(1,1,15) (solid)**, **Array I>arr1(1,1,16) (solid)**, **Array I>arr1(1,1,17) (solid)**, **Array I>arr1(1,1,18) (solid)**, **Array I>arr1(1,1,19) (solid)**, **Array I>arr1(1,1,20) (solid)**, **Array I>arr1(1,1,21) (solid)**, **Array I>arr1(1,1,22) (solid)**, **Array I>arr1(1,1,23) (solid)**, **Array I>arr1(1,1,24) (solid)**, **Array I>arr1(1,1,25) (solid)**, **Array I>arr1(1,1,26) (solid)**, **Array I>arr1(1,1,27) (solid)**, **Array I>arr1(1,1,28) (solid)**, **Array I>arr1(1,1,29) (solid)**, **Array I>arr1(1,1,30) (solid)**, **Array I>arr1(1,1,31) (solid)**, **Array I>arr1(1,1,32) (solid)**, **Array I>arr1(1,1,33) (solid)**, **Array I>arr1(1,1,34) (solid)**, **Array I>arr1(1,1,35) (solid)**, **Array I>arr1(1,1,36) (solid)**, **Array I>arr1(1,1,37) (solid)**, **Array I>arr1(1,1,38) (solid)**, **Array I>arr1(1,1,39) (solid)**, **Array I>arr1(1,1,40) (solid)**, **Array I>arr1(1,1,41) (solid)**, **Array I>arr1(1,1,42) (solid)**, **Array I>arr1(1,1,43) (solid)**, **Array I>arr1(1,1,44) (solid)**, **Array I>arr1(1,1,45) (solid)**, **Array I>arr1(1,1,46) (solid)**, **Array I>arr1(1,1,47) (solid)**, **Array I>arr1(1,1,48) (solid)**, **Array I>arr1(1,1,49) (solid)**, **Array I>arr1(1,1,50) (solid)**, and **mov1 (solid)**.

3 Click **Add to Active Selection for Union I (uni1)** in the window toolbar.

## GEOMETRY I

### *Union I (uni1)*

1 In the **Model Builder** window, click **Union I (uni1)**.

2 In the **Settings** window for **Union**, click  **Build Selected**.



### Cylinder 2 (cyl2)

- 1 In the **Geometry** toolbar, click  **Cylinder**.
- 2 In the **Settings** window for **Cylinder**, locate the **Size and Shape** section.
- 3 In the **Radius** text field, type 60.
- 4 In the **Height** text field, type 100.
- 5 Locate the **Position** section. In the **z** text field, type -100.
- 6 Click to expand the **Layers** section. In the table, enter the following settings:

Layer name	Thickness (m)
Layer 1	60

- 7 Clear the **Layers on side** check box.
- 8 Select the **Layers on bottom** check box.
- 9 Click  **Build Selected**.

### Block 2 (blk2)

- 1 In the **Geometry** toolbar, click  **Block**.
- 2 In the **Settings** window for **Block**, locate the **Size and Shape** section.
- 3 In the **Width** text field, type 150.
- 4 In the **Depth** text field, type 75.
- 5 In the **Height** text field, type 300.
- 6 Locate the **Position** section. In the **x** text field, type -75.
- 7 In the **y** text field, type -75.
- 8 In the **z** text field, type -150.
- 9 Click  **Build Selected**.

### Difference 1 (dif1)

In the **Geometry** toolbar, click  **Booleans and Partitions** and choose **Difference**.

### SELECTION LIST

- 1 Go to the **Selection List** window.
- 2 In the tree, select **cone1 (solid)**, **uni1 (solid)**, and **cyl2 (solid)**.
- 3 Click **Add to Active Selection for Difference 1 (dif1)** in the window toolbar.
- 4 In the **Settings** window for **Difference**, locate the **Difference** section.
- 5 Find the **Objects to subtract** subsection. Click to select the  **Activate Selection** toggle button.



- 6 Go to the **Selection List** window.
- 7 In the tree, select **blk2 (solid)**.
- 8 Click **Add to Active Selection for Difference I (dif1)** in the window toolbar.

## GEOMETRY I

### *Difference I (dif1)*

- 1 In the **Model Builder** window, click **Difference I (dif1)**.
- 2 In the **Settings** window for **Difference**, click  **Build Selected**.

### *Delete Entities I (del1)*

- 1 In the **Model Builder** window, right-click **Geometry I** and choose **Delete Entities**.
- 2 In the **Settings** window for **Delete Entities**, locate the **Entities or Objects to Delete** section.
- 3 From the **Geometric entity level** list, choose **Domain**.
- 4 On the object **dif1**, select Domains 4–7 only.

## GLOBAL DEFINITIONS

### *Parameters I*

- 1 In the **Model Builder** window, under **Global Definitions** click **Parameters I**.
- 2 In the **Settings** window for **Parameters**, locate the **Parameters** section.
- 3 In the table, enter the following settings:

Name	Expression	Value	Description
NanodeTp	10	10	Number of anodes around transition piece
NanodeMp	4	4	Number of anodes around monopile

## GEOMETRY I



### *Polygon I (pol1)*

- 1 In the **Geometry** toolbar, click  **More Primitives** and choose **Polygon**.
- 2 In the **Settings** window for **Polygon**, locate the **Coordinates** section.
- 3 In the table, enter the following settings:



x (m)	y (m)	z (m)
-2.4	0	-4
-2.3	0	-2

- 4 Locate the **Selections of Resulting Entities** section. Find the **Cumulative selection** subsection. Click **New**.
- 5 In the **New Cumulative Selection** dialog box, type AnodeTp in the **Name** text field.
- 6 Click **OK**.

#### *Rotate 1 (rot1)*

- 1 In the **Geometry** toolbar, click  **Transforms** and choose **Rotate**.
- 2 In the **Settings** window for **Rotate**, locate the **Input** section.
- 3 From the **Input objects** list, choose **AnodeTp**.
- 4 Locate the **Rotation** section. In the **Angle** text field, type  $-\text{range}(180/\text{NanodeTp}, 360/\text{NanodeTp}, 180 - 180/\text{NanodeTp})$ .
- 5 Locate the **Selections of Resulting Entities** section. Find the **Cumulative selection** subsection. From the **Contribute to** list, choose **AnodeTp**.
- 6 Click  **Build Selected**.

#### *Copy 2 (copy2)*



- 1 In the **Geometry** toolbar, click  **Transforms** and choose **Copy**.
- 2 In the **Settings** window for **Copy**, locate the **Input** section.
- 3 Click  **Paste Selection**.
- 4 In the **Paste Selection** dialog box, type rot1(1) rot1(2) rot1(3) rot1(4) rot1(5) in the **Selection** text field.
- 5 Click **OK**.
- 6 Select the objects **rot1(1)**, **rot1(2)**, **rot1(3)**, **rot1(4)**, and **rot1(5)** only.
- 7 In the **Settings** window for **Copy**, locate the **Displacement** section.
- 8 In the **z** text field, type -8.
- 9 Locate the **Selections of Resulting Entities** section. Find the **Cumulative selection** subsection. From the **Contribute to** list, choose **AnodeTp**.
- 10 Click  **Build Selected**.

#### *Polygon 2 (pol2)*



- 1 In the **Geometry** toolbar, click  **More Primitives** and choose **Polygon**.
- 2 In the **Settings** window for **Polygon**, locate the **Coordinates** section.
- 3 From the **Data source** list, choose **Vectors**.
- 4 In the **x** text field, type 2.5.
- 5 In the **y** text field, type 0.

- 6 In the **z** text field, type -16 -18.
- 7 Locate the **Selections of Resulting Entities** section. Find the **Cumulative selection** subsection. Click **New**.
- 8 In the **New Cumulative Selection** dialog box, type AnodeMp in the **Name** text field.
- 9 Click **OK**.



#### *Array 2 (arr2)*

- 1 In the **Geometry** toolbar, click  **Transforms** and choose **Array**.
- 2 In the **Settings** window for **Array**, locate the **Input** section.
- 3 From the **Input objects** list, choose **AnodeMp**.
- 4 Locate the **Size** section. In the **z size** text field, type 4.
- 5 Locate the **Displacement** section. In the **z** text field, type -6.
- 6 Click  **Build Selected**.

#### *Rotate 2 (rot2)*

- 1 In the **Geometry** toolbar, click  **Transforms** and choose **Rotate**.
- 2 In the **Settings** window for **Rotate**, locate the **Input** section.
- 3 Click  **Paste Selection**.
- 4 In the **Paste Selection** dialog box, type arr2(1,1,1) arr2(1,1,2) arr2(1,1,3) arr2(1,1,4) in the **Selection** text field.
- 5 Click **OK**.
- 6 Select the objects **arr2(1,1,1)**, **arr2(1,1,2)**, **arr2(1,1,3)**, and **arr2(1,1,4)** only.
- 7 In the **Settings** window for **Rotate**, locate the **Rotation** section.
- 8 In the **Angle** text field, type range(180/NanodeMp,360/NanodeMp,180-180/NanodeMp).
- 9 Locate the **Selections of Resulting Entities** section. Find the **Cumulative selection** subsection. From the **Contribute to** list, choose **AnodeMp**.
- 10 Click  **Build Selected**.

#### *Anodes*

- 1 In the **Geometry** toolbar, click  **Selections** and choose **Union Selection**.
- 2 In the **Settings** window for **Union Selection**, type Anodes in the **Label** text field.
- 3 Locate the **Geometric Entity Level** section. From the **Level** list, choose **Edge**.
- 4 Locate the **Input Entities** section. Click  **Add**.
- 5 In the **Add** dialog box, in the **Selections to add** list, choose **AnodeTp** and **AnodeMp**.

6 Click **OK**.

*Rotate 3 (rot3)*

1 In the **Geometry** toolbar, click  **Transforms** and choose **Rotate**.

2 In the **Settings** window for **Rotate**, locate the **Input** section.

3 Click  **Paste Selection**.

4 In the **Paste Selection** dialog box, type del1 rot1(1) rot1(2) rot1(3) rot1(4) rot1(5) copy2(1) copy2(2) copy2(3) copy2(4) copy2(5) del1 rot1(1) rot1(2) rot1(3) rot1(4) rot1(5) rot2(1) rot2(2) rot2(3) rot2(4) rot2(5) rot2(6) rot2(7) rot2(8) in the **Selection** text field.

5 Click **OK**.

6 Click in the **Graphics** window and then press Ctrl+A to select all objects.

7 In the **Settings** window for **Rotate**, locate the **Rotation** section.

8 In the **Angle** text field, type 180.

9 Click  **Build Selected**.