

Muffler with Perforates

Introduction

The original version of this model was developed by Dr. Sabry Allam and Prof. Mats Åbom at the Marcus Wallenberg Laboratory for Sound and Vibration Research, Royal Institute of Technology, Stockholm, Sweden. Dr. Allam and Prof. Åbom also provided the experimental data used in the model.

There are two basic types of mufflers:

- *Reflective (or reactive) mufflers* — those that reflect acoustic waves by abrupt area expansions or changes of impedance.
- *Dissipative mufflers* — mufflers based on dissipation of acoustic energy into heat through viscous and thermal losses in fibrous materials or flow-related (resistive) losses in perforated pipes.

Reflective mufflers are best suited for the low frequency range where only plane waves can propagate in the system, while dissipative mufflers with fibers are efficient in the mid-to-high frequency range. Dissipative mufflers based on flow losses, on the other hand, work also at low frequencies. A typical automotive exhaust system is a hybrid construction consisting of a combination of reflective and dissipative muffler elements. The reflective parts are normally tuned to remove dominating low-frequency engine harmonics while the dissipative parts are designed to take care of higher-frequency noise.

In the industry, exhaust systems are typically analyzed with nonlinear 1D gas-dynamics codes. Such codes, however, do not capture 3D acoustic effects such as higher-order duct modes, and the modeling of fibrous materials is not satisfactory. In practice, there is therefore a need to use linear acoustic models of exhaust and intake systems to enable detailed modeling and optimization of the acoustic response, at the cost of neglecting nonlinear effects. The Port boundary conditions enable the analysis of plane waves and higher order modes above their cutoff frequency propagating through the inlet and outlet. In this model, we stay below the cutoff frequency of the first mode and only model the plane wave propagation.

Model Definition

The muffler you analyze here is an example of a complex hybrid muffler in which the dissipative element is created completely by flow through perforated pipes and plates.

When designing a model for a muffler without fibrous materials you need to consider the following aspects:

- *Geometry* — The design for this model is based on a modular muffler developed for research purposes. It closely resembles commercially available automotive mufflers, and was used as a test case for muffler modeling in an EC-project (ARTEMIS).
- *Mean flow distribution* — The Mach number in an exhaust system is normally less than 0.3. This means that in mufflers with flow expansions, the average Mach number is quite small (less than 0.1). For such cases, you can neglect the convective flow effects, and the only important effect of the mean flow is its influence on the impedance of perforated pipes/plates. This model treats the case where there is no mean flow in the muffler.
- *Temperature distribution* — In a running engine, the air temperature inside the muffler is typically in the range 300–400 °C. There is also a temperature gradient through the muffler. However, the acoustic effect of this gradient is small and the average temperature is normally used to calculate the speed of sound. In this case, the experiments were performed at room temperature (20 °C). The model therefore assumes the temperature in the muffler to be constant and uses the default values for air density and speed of sound at 1 atm and 20 °C.

A schematic cross section of the muffler geometry is shown in [Figure 1](#).

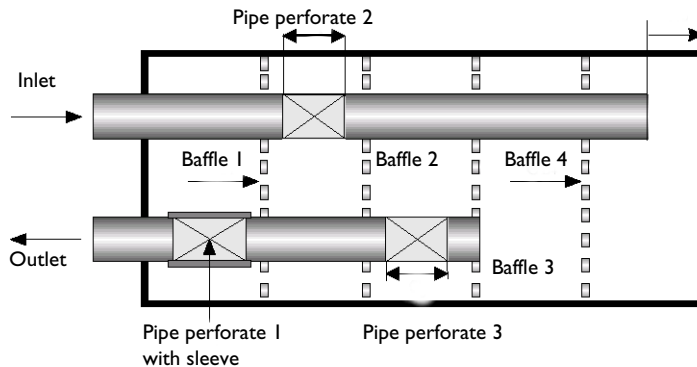

Figure 1: Muffler geometry cross section.

The detailed design and dimensions of the outlet pipe and the four baffles (as seen from the right in [Figure 1](#)) are given in [Figure 2](#) through [Figure 5](#).

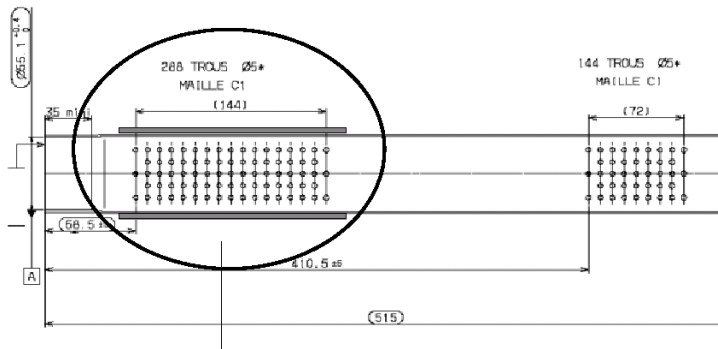

Figure 2: Outlet pipe. A stainless steel sleeve is located above the left perforated section with 288 holes. The other two pipe perforates contain 144 holes each.

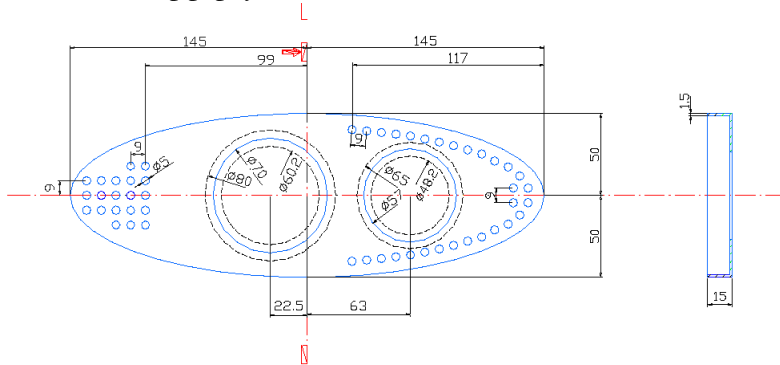

Figure 3: Baffle number 1, outlet side to the left and inlet side to the right.

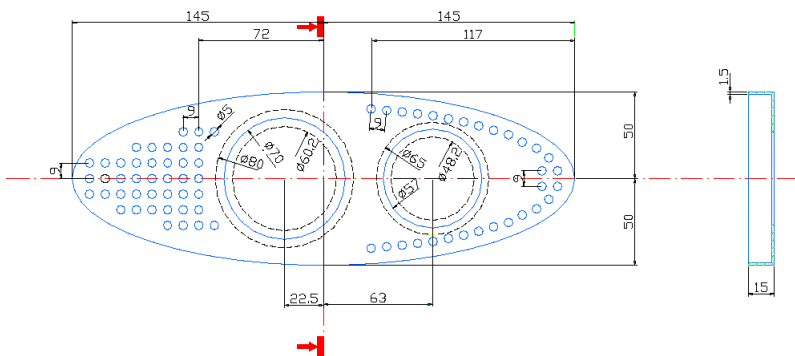

Figure 4: Baffles number 2 and 3.

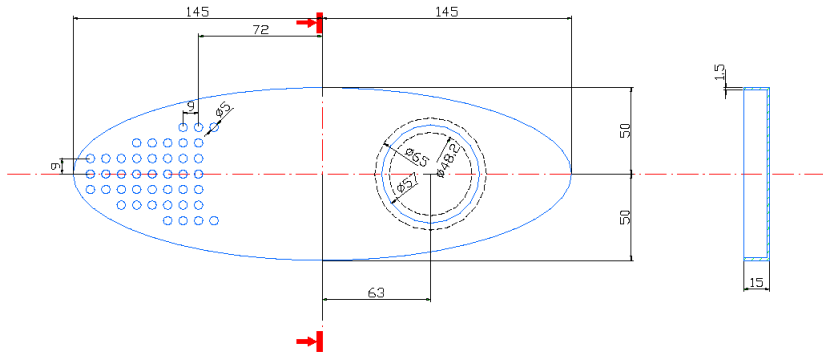

Figure 5: Baffle number 4.

The model geometry is supplied as a CAD file. To reduce computation time only the upper half of the muffler is included; a symmetry condition is added at $z = 0$. (A careful inspection of the drawings in [Figure 3](#)–[Figure 5](#) shows that the reflection symmetry is not perfect for the perforates on the outlet side. However, the asymmetry is so minor that it is safe to neglect its effects.)

In the CAD geometry, the perforated regions are outlined by edges drawn on the corresponding boundaries. This is illustrated for baffle number 1 in [Figure 6](#) where the perforated regions have been shaded for emphasis.

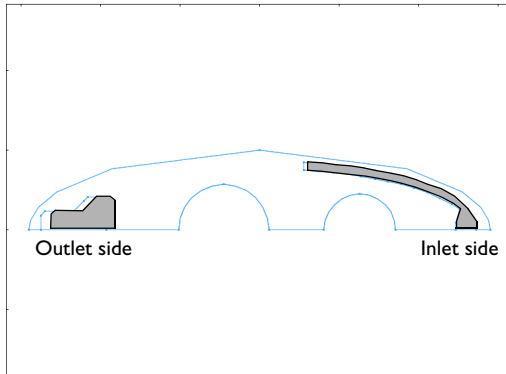

Figure 6: Perforated regions of baffle number 1.

You model the acoustic effects of the perforates by applying the Acoustics Module’s Interior Perforated Plate boundary condition on these regions. A thorough description of

the perforated plate impedance models is available in the section *Theory for the Interior Impedance Models* in the *Acoustics Module User's Guide*. The expression for the transfer impedance Z_i of the plate depends on the chosen model type, but is in general a function of the plate geometry, the porosity pattern, the material parameters of the fluid, and the wave number k . The last is given by $2\pi f/c$ where f denotes the frequency. You run the simulation for a range of frequencies between 20 Hz and 600 Hz.

The Interior Perforated Plate boundary condition also allows user defined contributions to the impedance. For example, you will specify the additional resistance caused by a mean flow in the muffler to include the effects of the metallic sleeve above pipe perforate number 1. For details about the effect of flow see [Ref. 1](#), [Ref. 2](#), and [Ref. 3](#).

The relevant input parameters for the model are listed in [Table 1](#). The porosity values were obtained by dividing the total area of the holes in each perforate with the area of the corresponding region in the CAD geometry. The resistance of the metallic sleeve was experimentally measured.

TABLE 1: MODEL INPUT PARAMETERS.

PROPERTY	VALUE	DESCRIPTION
t_p	1.5 mm	Plate thickness
d_h	5 mm	Hole diameter in perforates
σ_p	0.22	Porosity, pipe perforates
σ_{bi}	0.46	Porosity, baffle perforates on inlet side
σ_{bo}	0.30	Porosity, baffle perforates on outlet side
θ_{sleeve}	1	Specific resistance, metallic sleeve

The parameters related to the material are taken from the surrounding fluid material data.

Results and Discussion

The transmission loss in the muffler is defined as

$$TL = 10 \log_{10} \left(\frac{P_{in}}{P_{out}} \right) \quad (1)$$

where P_{in} and P_{out} denote the total acoustic power at the inlet and the outlet, respectively. The incident and outgoing power flow is automatically calculated by the Port boundary conditions (variables `acpr.port1.P_in` and `acpr.port2.P_out`). The Port boundary condition automatically registers the symmetry condition, and calculates the correct total power. For plane wave excitation it is relatively straightforward to calculate the power (it

is proportional to p^2), however this becomes much more complicated if higher order modes are included. This is taken care of by the built-in expressions available with the Port boundary conditions. Figure 7 displays the Acoustics Module modeling results for the transmission loss as a function of sound frequency together with experimentally measured values.

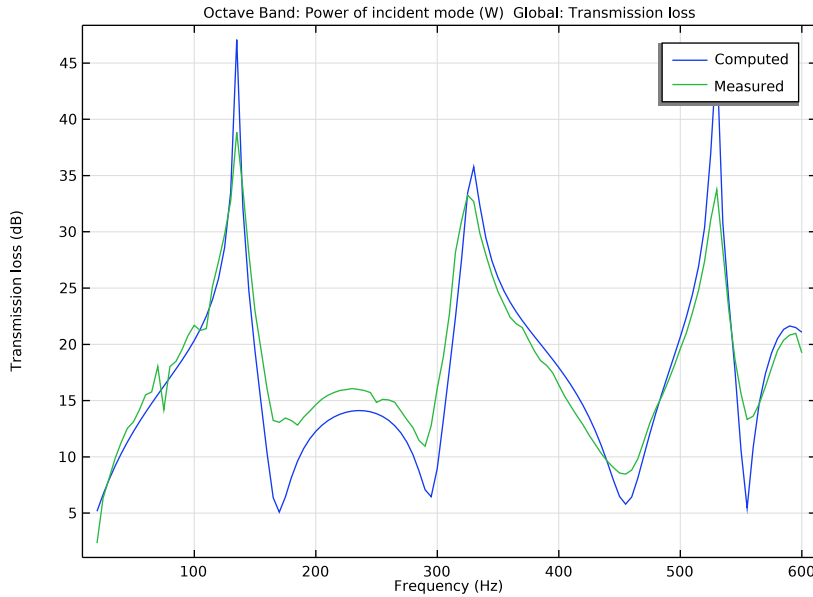

Figure 7: Transmission loss versus frequency: model simulation results and experimentally measured values.

As the figure shows, the agreement is excellent except in the range 170–300 Hz. The relatively limited agreement in the range of 170–300 Hz could be caused by the effects of the flow on the acoustic field, as the measurements were done with air flowing through the muffler. The current model only considers the additional resistance of the perforated plates due to the flow, while in reality the flow will have a more complex effect.

As the acoustic excitation goes higher in frequency, it will start to induce vibrations in the outer shell. The agreement at high frequencies can be improved by including the effect of the shell vibrations as illustrated in the Application Gallery model “Absorptive Muffler with Shells” (www.comsol.com/model/absorptive-muffler-with-shells-14717).

You can get a better sense of the results by studying the sound pressure level field inside the muffler for selected frequencies. The plots in Figure 8 display this field for the frequencies 530 Hz and 555 Hz, respectively. As Figure 7 shows, the former frequency

corresponds to a local maximum for the transmission loss whereas the latter gives a local minimum. In [Figure 8](#) you can see these how these properties are related to the sound pressure level distributions near the muffler inlet and outlet.

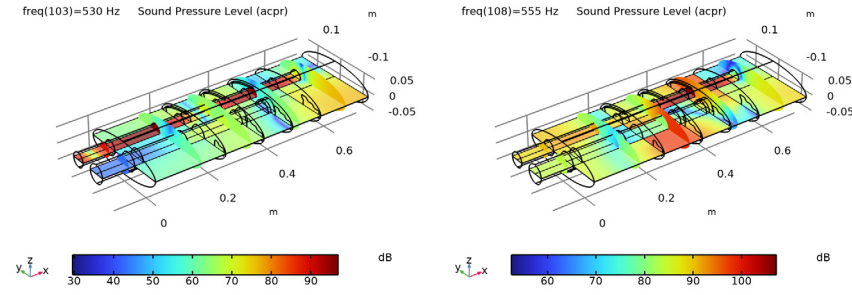

Figure 8: Sound pressure level distributions at 530 Hz (left) and 555 Hz (right).

The propagation of the acoustic energy through the muffler system is illustrated in [Figure 9](#) as a streamline plot of the acoustic intensity vector.

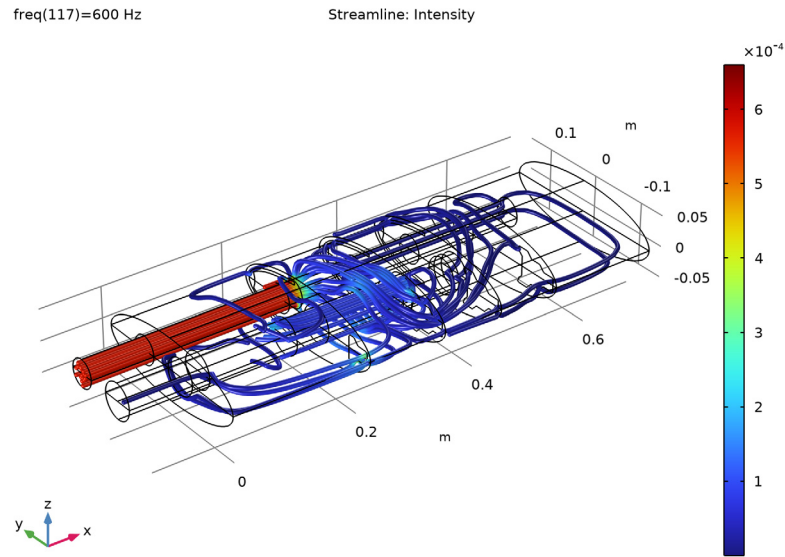

Figure 9: Streamline plot of the acoustic intensity field. The color scale represents the magnitude of the acoustic intensity vector.

References

1. E.J. Rice, “A Theoretical Study of the Acoustic Impedance of Orifices in the Presence of a Steady Grazing Flow,” *NASA report TM X-71903*, 1976.
 2. T. Elnady, *Modelling and Characterization of Perforates in Lined Ducts and Mufflers*, doctoral dissertation, Dept. Aeronautical and Vehicle Eng., Royal Institute of Technology, Stockholm, 2004.
 3. R. Kirby, “Transmission Loss Predictions for Dissipative Silencers of Arbitrary Cross Section in the Presence of Mean Flow,” *J. Acoust. Soc. Am.*, vol. 114, pp. 200–209, 2003.
-

Application Library path: Acoustics_Module/Automotive/perforated_muffler



Modeling Instructions

From the **File** menu, choose **New**.

NEW

In the **New** window, click  **Model Wizard**.

MODEL WIZARD

- 1 In the **Model Wizard** window, click  **3D**.
- 2 In the **Select Physics** tree, select **Acoustics>Pressure Acoustics>Pressure Acoustics, Frequency Domain (acpr)**.
- 3 Click **Add**.
- 4 Click  **Study**.
- 5 In the **Select Study** tree, select **General Studies>Frequency Domain**.
- 6 Click  **Done**.

GEOMETRY I

A horizontal symmetry plane through the muffler means that it is sufficient to model only half of the geometry. Here, the entire geometry is imported as a sequence from the geometry file. The instructions to the geometry can be found in the appendix at the end of this document.

- 1 In the **Geometry** toolbar, click **Insert Sequence** and choose **Insert Sequence**.

2 Browse to the model's Application Libraries folder and double-click the file `perforated_muffler_geom_sequence.mph`.

3 In the **Geometry** toolbar, click  **Build All**.

You should now see the upper half of a muffler in the drawing area.

ROOT

Enter the parameters needed for the model or load them from the file `perforated_muffler_parameters.txt`.

GLOBAL DEFINITIONS

Parameters 1

1 In the **Model Builder** window, under **Global Definitions** click **Parameters 1**.

2 In the **Settings** window for **Parameters**, locate the **Parameters** section.

3 In the table, enter the following settings:

Name	Expression	Value	Description
<code>p0</code>	<code>1 [Pa]</code>	<code>1 Pa</code>	Inlet pressure
<code>t_w</code>	<code>1.5 [mm]</code>	<code>0.0015 m</code>	Wall thickness
<code>d_h</code>	<code>5 [mm]</code>	<code>0.005 m</code>	Hole diameter
<code>sigma_p</code>	<code>0.22</code>	<code>0.22</code>	Porosity, pipe perforates
<code>sigma_bi</code>	<code>0.46</code>	<code>0.46</code>	Porosity, baffles on inlet side
<code>sigma_bo</code>	<code>0.3</code>	<code>0.3</code>	Porosity, baffles on outlet side

DEFINITIONS

Define the following interpolation function (measurement data) and variable definitions so that you can compute the transmission loss and compare it with experimental data.

Interpolation 1 (int1)

1 In the **Home** toolbar, click  **Functions** and choose **Local>Interpolation**.

2 In the **Settings** window for **Interpolation**, locate the **Definition** section.

3 From the **Data source** list, choose **File**.

4 Click  **Browse**.

5 Browse to the model's Application Libraries folder and double-click the file `perforated_muffler_exp_data.txt`.

6 Click  **Import**.

7 In the **Function name** text field, type TL_exp.

MATERIALS

The walls of the muffler are considered perfectly rigid and will not use any material properties. The only material you need to select is air.

ADD MATERIAL

1 In the **Home** toolbar, click  **Add Material** to open the **Add Material** window.

2 Go to the **Add Material** window.

3 In the tree, select **Built-in>Air**.

4 Click **Add to Component** in the window toolbar.

5 In the **Home** toolbar, click  **Add Material** to close the **Add Material** window.

PRESSURE ACOUSTICS, FREQUENCY DOMAIN (ACPR)

With all selections, variables, and material settings completed, it is time to set up the physics.

All boundaries that are exterior to the geometry are by default assigned the Sound Hard boundary condition. Start by applying the Interior Sound Hard condition to the interior rigid walls.

Interior Sound Hard Boundary (Wall) 1

1 In the **Model Builder** window, under **Component 1 (comp1)** right-click **Pressure Acoustics, Frequency Domain (acpr)** and choose **Interior Conditions> Interior Sound Hard Boundary (Wall)**.

2 In the **Settings** window for **Interior Sound Hard Boundary (Wall)**, locate the **Boundary Selection** section.

3 From the **Selection** list, choose **Interior Hard Walls**.

You need four Interior Perforated Plate conditions, one for each different set of parameters. The Thin plate (default) model type is appropriate here since the value kt_p is much less than 1.

Interior Perforated Plate 1

1 In the **Physics** toolbar, click  **Boundaries** and choose **Interior Perforated Plate**.

2 In the **Settings** window for **Interior Perforated Plate**, locate the **Boundary Selection** section.

3 From the **Selection** list, choose **Pipe Perforates**.

- 4 Locate the **Interior Perforated Plate** section. In the σ text field, type `sigma_p`.
- 5 In the t_p text field, type `t_w`.
- 6 In the d_h text field, type `d_h`.
- 7 Locate the **Fluid Properties** section. From the **Fluid material** list, choose **Air (mat I)**.

Interior Perforated Plate 2

- 1 In the **Physics** toolbar, click  **Boundaries** and choose **Interior Perforated Plate**.
- 2 In the **Settings** window for **Interior Perforated Plate**, locate the **Boundary Selection** section.
- 3 From the **Selection** list, choose **Pipe Perforate with Sleeve**.
- 4 Locate the **Interior Perforated Plate** section. In the σ text field, type `sigma_p`.
- 5 In the t_p text field, type `t_w`.
- 6 In the d_h text field, type `d_h`.
- 7 Locate the **Fluid Properties** section. From the **Fluid material** list, choose **Air (mat I)**.
- 8 Locate the **Interior Perforated Plate** section. Select the **User-defined contribution** check box.
- 9 In the $\theta^{(\text{user})}$ text field, type 1.

The user-defined resistance represents the impedance contribution from the metallic sleeve outside the pipe.

Interior Perforated Plate 3

- 1 In the **Physics** toolbar, click  **Boundaries** and choose **Interior Perforated Plate**.
- 2 In the **Settings** window for **Interior Perforated Plate**, locate the **Boundary Selection** section.
- 3 From the **Selection** list, choose **Inlet Baffle Perforates**.
- 4 Locate the **Interior Perforated Plate** section. In the σ text field, type `sigma_bi`.
- 5 In the t_p text field, type `t_w`.
- 6 In the d_h text field, type `d_h`.
- 7 Locate the **Fluid Properties** section. From the **Fluid material** list, choose **Air (mat I)**.

Interior Perforated Plate 4

- 1 In the **Physics** toolbar, click  **Boundaries** and choose **Interior Perforated Plate**.
- 2 In the **Settings** window for **Interior Perforated Plate**, locate the **Boundary Selection** section.
- 3 From the **Selection** list, choose **Outlet Baffle Perforates**.

4 Locate the **Interior Perforated Plate** section. In the σ text field, type `sigma_bo`.

5 In the t_p text field, type `t_w`.

6 In the d_h text field, type `d_h`.

7 Locate the **Fluid Properties** section. From the **Fluid material** list, choose **Air (mat1)**.

Use the Port boundary conditions at the inlet and outlet. Note that the first port at the inlet has an incident field excitation. Both ports capture ingoing and outgoing plane-wave modes. If the frequency range is extended above the cutoff frequency of the first non-plane mode, then add more ports at the inlet and outlet to capture these. The cutoff frequency of a port can be evaluated in postprocessing.

Port 1

1 In the **Physics** toolbar, click  **Boundaries** and choose **Port**.

2 In the **Settings** window for **Port**, locate the **Boundary Selection** section.

3 From the **Selection** list, choose **Inlet**.

4 Locate the **Port Properties** section. From the **Type of port** list, choose **Circular**.

5 Locate the **Incident Mode Settings** section. In the A^{in} text field, type `p0`.

Circular Port Reference Axis 1

1 In the **Physics** toolbar, click  **Attributes** and choose **Circular Port Reference Axis**.

Select two points at the inlet boundary to define the reference for the azimuthal angle. This becomes important if higher-order modes are included in the model. Note that because of the symmetry only certain symmetric modes should be selected.

2 In the **Settings** window for **Circular Port Reference Axis**, locate the **Point Selection** section.

3 Click  **Clear Selection**.

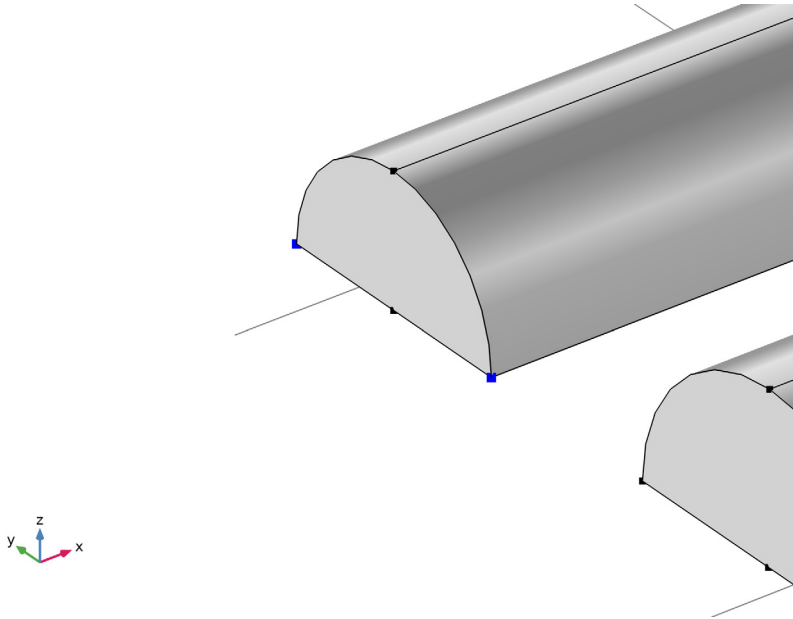

4 Select Points 5 and 8 only.



Port 2

- 1 In the **Physics** toolbar, click  **Boundaries** and choose **Port**.
- 2 In the **Settings** window for **Port**, locate the **Boundary Selection** section.
- 3 From the **Selection** list, choose **Outlet**.
- 4 Locate the **Port Properties** section. From the **Type of port** list, choose **Circular**.

Circular Port Reference Axis 1

- 1 In the **Physics** toolbar, click  **Attributes** and choose **Circular Port Reference Axis**.
- 2 In the **Settings** window for **Circular Port Reference Axis**, locate the **Point Selection** section.
- 3 Click  **Clear Selection**.
- 4 Select Points 1 and 4 only.

Symmetry 1

- 1 In the **Physics** toolbar, click  **Boundaries** and choose **Symmetry**.
- 2 In the **Settings** window for **Symmetry**, locate the **Boundary Selection** section.
- 3 From the **Selection** list, choose **Symmetry**.

MESH

Proceed and generate the mesh using the **Physics-controlled mesh** functionality. The frequency controlling the maximum element size is per default taken **From study**. Set the desired **Frequencies** in the study step. In general, 5 to 6 second-order elements per wavelength are needed to resolve the waves. For more details, see *Meshing (Resolving the Waves)* in the *Acoustics Module User's Guide*. In this model, we use 8 elements per wavelength; the default **Automatic** is to have 5.

STUDY I

Select to solve for the frequency range from 20 Hz to 600 Hz, in steps of 5 Hz.

Step 1: Frequency Domain

- 1 In the **Model Builder** window, under **Study I** click **Step 1: Frequency Domain**.
- 2 In the **Settings** window for **Frequency Domain**, locate the **Study Settings** section.
- 3 In the **Frequencies** text field, type range (20, 5, 600).

MESH I

- 1 In the **Model Builder** window, under **Component 1 (comp1)** click **Mesh I**.
- 2 In the **Settings** window for **Mesh**, locate the **Pressure Acoustics, Frequency Domain (acpr)** section.
- 3 From the **Number of mesh elements per wavelength** list, choose **User defined**.
- 4 In the text field, type 8.
- 5 Click  **Build All**.

STUDY I

In the **Home** toolbar, click  **Compute**.

RESULTS

Create a Mirror 3D dataset in order to visualize the solution on the full geometry.

Mirror 3D 1

- 1 In the **Results** toolbar, click  **More Datasets** and choose **Mirror 3D**.
- 2 In the **Settings** window for **Mirror 3D**, locate the **Plane Data** section.
- 3 From the **Plane** list, choose **XY-planes**.

Acoustic Pressure (acpr)

- 1 In the **Model Builder** window, under **Results** click **Acoustic Pressure (acpr)**.
- 2 In the **Settings** window for **3D Plot Group**, locate the **Data** section.

3 From the **Dataset** list, choose **Mirror 3D I**.

4 In the **Acoustic Pressure (acpr)** toolbar, click  **Plot**.

freq(117)=600 Hz

Surface: Total acoustic pressure (Pa)

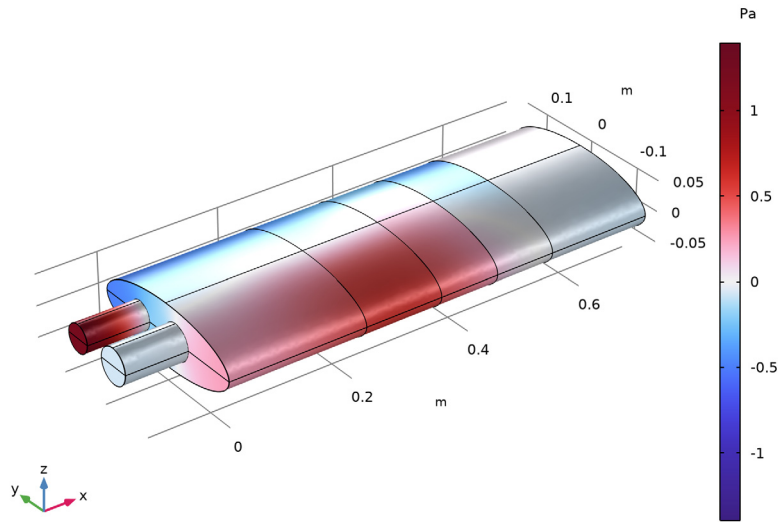

The plot shows the pressure distribution on the surface of the muffler. Follow the instructions to see the sound pressure level on a slice inside it.

Surface 1

1 In the **Model Builder** window, expand the **Results>Sound Pressure Level (acpr)** node.

2 Right-click **Surface 1** and choose **Disable**.

Sound Pressure Level (acpr)

1 In the **Model Builder** window, click **Sound Pressure Level (acpr)**.

2 In the **Settings** window for **3D Plot Group**, locate the **Data** section.

3 From the **Dataset** list, choose **Mirror 3D I**.

Multislice 1

1 In the **Sound Pressure Level (acpr)** toolbar, click  **More Plots** and choose **Multislice**.

2 In the **Settings** window for **Multislice**, click **Replace Expression** in the upper-right corner of the **Expression** section. From the menu, choose **Component 1 (comp 1)>**

Pressure Acoustics, Frequency Domain>Pressure and sound pressure level>acpr.Lp_t - Total sound pressure level - dB.

- 3 Locate the **Multipane Data** section. Find the **x-planes** subsection. In the **Planes** text field, type 5.
- 4 Find the **y-planes** subsection. In the **Planes** text field, type 0.
- 5 In the **Sound Pressure Level (acpr)** toolbar, click  **Plot**.

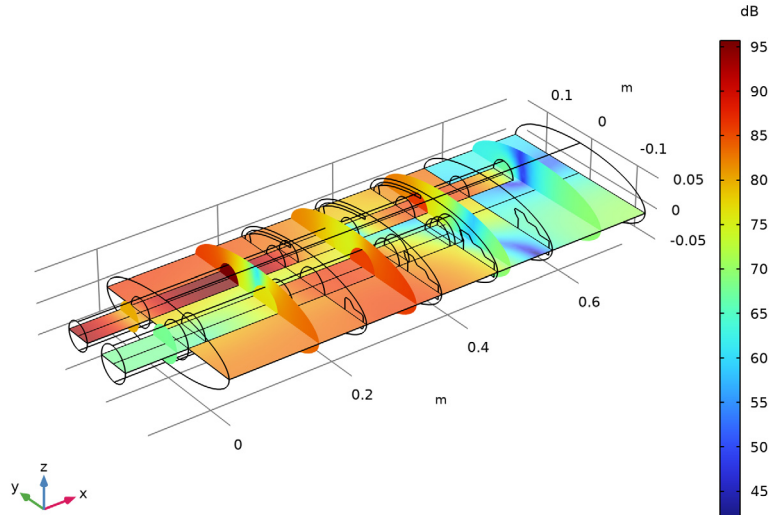

freq(117)=600 Hz

Multislice: Total sound pressure level (dB)



At 600 Hz, most of the sound leaves the inlet pipe through the perforate. Take a look at some other frequencies to reproduce [Figure 8](#).

Sound Pressure Level (acpr)

- 1 In the **Model Builder** window, click **Sound Pressure Level (acpr)**.
- 2 In the **Settings** window for **3D Plot Group**, locate the **Data** section.
- 3 From the **Parameter value (freq (Hz))** list, choose **530**.
- 4 Click to expand the **Title** section. From the **Title type** list, choose **Label**.
- 5 Locate the **Color Legend** section. From the **Position** list, choose **Bottom**.
- 6 In the **Sound Pressure Level (acpr)** toolbar, click  **Plot**.
- 7 Locate the **Data** section. From the **Parameter value (freq (Hz))** list, choose **555**.
- 8 In the **Sound Pressure Level (acpr)** toolbar, click  **Plot**.

Acoustic Pressure, Isosurfaces (acpr)

- 1 In the **Model Builder** window, click **Acoustic Pressure, Isosurfaces (acpr)**.

- 2 In the **Settings** window for **3D Plot Group**, locate the **Data** section.
- 3 From the **Dataset** list, choose **Mirror 3D 1**.
- 4 In the **Acoustic Pressure, Isosurfaces (acpr)** toolbar, click  **Plot**.

The last default plot, depicting pressure isosurfaces should look like the figure below.

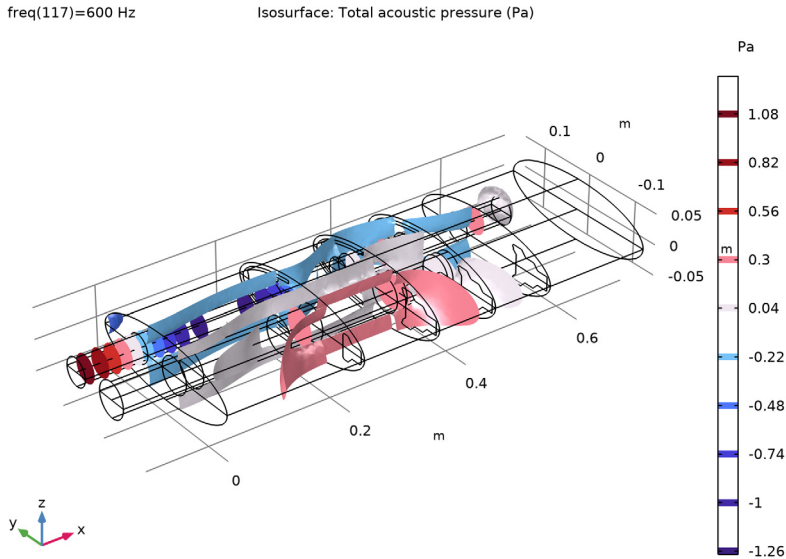

To study the transmission loss as a function of the frequency and reproduce [Figure 7](#), add a 1D plot.

Transmission Loss

- 1 In the **Home** toolbar, click  **Add Plot Group** and choose **1D Plot Group**.
- 2 In the **Settings** window for **1D Plot Group**, type Transmission Loss in the **Label** text field.
- 3 Locate the **Plot Settings** section.
- 4 Select the **x-axis label** check box. In the associated text field, type Frequency (Hz).
- 5 Select the **y-axis label** check box. In the associated text field, type Transmission loss (dB).
- 6 In the **Model Builder** window, click **Transmission Loss**.

Octave Band 1

- 1 In the **Transmission Loss** toolbar, click  **More Plots** and choose **Octave Band**.

- 2 In the **Settings** window for **Octave Band**, locate the **Selection** section.
- 3 From the **Geometric entity level** list, choose **Global**.
- 4 Locate the **y-Axis Data** section. From the **Expression type** list, choose **Power**.
- 5 In the **Expression** text field, type `acpr.port1.P_in`.
- 6 In the **Power reference** text field, type `acpr.port2.P_out`.
- 7 Locate the **Plot** section. From the **Quantity** list, choose **Continuous power spectral density**.
- 8 Click to expand the **Legends** section. Select the **Show legends** check box.
- 9 From the **Legends** list, choose **Manual**.
- 10 In the table, enter the following settings:

Legends
Computed

Transmission Loss

Right-click **Octave Band I** and choose **Global**.

Global I

- 1 In the **Settings** window for **Global**, locate the **y-Axis Data** section.
- 2 In the table, enter the following settings:

Expression	Unit	Description
TL_exp(freq)		Transmission loss

- 3 Click to expand the **Coloring and Style** section. Find the **Line markers** subsection. From the **Marker** list, choose **None**.
- 4 Click to expand the **Legends** section. From the **Legends** list, choose **Manual**.
- 5 In the table, enter the following settings:

Legends
Measured

Transmission Loss

- 1 In the **Model Builder** window, click **Transmission Loss**.
- 2 In the **Settings** window for **ID Plot Group**, locate the **Axis** section.
- 3 Clear the **x-axis log scale** check box.

- 4 In the **Transmission Loss** toolbar, click  **Plot**.

Finally, create a streamline plot of the acoustic intensity vector (SI unit: W/m^2) in order to visualize the direction of propagation of the acoustic energy in the muffler system.

Intensity

- 1 In the **Home** toolbar, click  **Add Plot Group** and choose **3D Plot Group**.
- 2 In the **Settings** window for **3D Plot Group**, type **Intensity** in the **Label** text field.
- 3 Locate the **Data** section. From the **Dataset** list, choose **Mirror 3D I**.

Streamline I

- 1 Right-click **Intensity** and choose **Streamline**.
- 2 In the **Settings** window for **Streamline**, click **Replace Expression** in the upper-right corner of the **Expression** section. From the menu, choose **Component I (comp I)> Pressure Acoustics, Frequency Domain>Intensity>acpr.lx,acpr.ly,acpr.lz - Intensity**.
- 3 Locate the **Coloring and Style** section. Find the **Line style** subsection. From the **Type** list, choose **Tube**.

Color Expression I

- 1 Right-click **Streamline I** and choose **Color Expression**.
- 2 In the **Settings** window for **Color Expression**, click **Replace Expression** in the upper-right corner of the **Expression** section. From the menu, choose **Component I (comp I)> Pressure Acoustics, Frequency Domain>Intensity>acpr.l_mag - Intensity magnitude - W/m^2** .
- 3 In the **Intensity** toolbar, click  **Plot**.

The result should look like the plot in [Figure 9](#).

Appendix: Geometry Sequence Instructions

ADD COMPONENT

In the **Home** toolbar, click  **Add Component** and choose **3D**.

GEOMETRY I

Work Plane I (wp1)

- 1 In the **Geometry** toolbar, click  **Work Plane**.
- 2 In the **Settings** window for **Work Plane**, locate the **Plane Definition** section.
- 3 From the **Plane** list, choose **yz-plane**.

Work Plane 1 (wp1)>Plane Geometry

In the **Model Builder** window, click **Plane Geometry**.

Work Plane 1 (wp1)>Ellipse 1 (e1)

- 1 In the **Work Plane** toolbar, click  **Ellipse**.
- 2 In the **Settings** window for **Ellipse**, locate the **Size and Shape** section.
- 3 In the **a-semiaxis** text field, type 0.145.
- 4 In the **b-semiaxis** text field, type 0.05.
- 5 In the **Sector angle** text field, type 180.

Extrude 1 (ext1)

- 1 In the **Model Builder** window, under **Component 1 (comp1)>Geometry 1** right-click **Work Plane 1 (wp1)** and choose **Extrude**.
- 2 In the **Settings** window for **Extrude**, locate the **Distances** section.
- 3 In the table, enter the following settings:

Distances (m)
0.225
0.225+0.128
0.225+0.128+0.098
0.225+0.128+0.098+0.098
0.225+0.128+0.098+0.098+0.171

Work Plane 2 (wp2)

- 1 In the **Geometry** toolbar, click  **Work Plane**.
- 2 In the **Settings** window for **Work Plane**, locate the **Plane Definition** section.
- 3 From the **Plane** list, choose **yz-plane**.
- 4 In the **x-coordinate** text field, type -0.1.
- 5 Locate the **Unite Objects** section. Clear the **Unite objects** check box.

Work Plane 2 (wp2)>Plane Geometry

In the **Model Builder** window, click **Plane Geometry**.

Work Plane 2 (wp2)>Circle 1 (c1)

- 1 In the **Work Plane** toolbar, click  **Circle**.
- 2 In the **Settings** window for **Circle**, locate the **Size and Shape** section.
- 3 In the **Radius** text field, type 28.5[mm].

- 4 In the **Sector angle** text field, type 180.
- 5 Locate the **Position** section. In the **xw** text field, type -22.5[mm].

Work Plane 2 (wp2)>Circle 2 (c2)

- 1 In the **Work Plane** toolbar, click  **Circle**.
- 2 In the **Settings** window for **Circle**, locate the **Size and Shape** section.
- 3 In the **Radius** text field, type 22.5[mm].
- 4 In the **Sector angle** text field, type 180.
- 5 Locate the **Position** section. In the **xw** text field, type 63[mm].

Extrude 2 (ext2)

- 1 In the **Model Builder** window, under **Component 1 (comp1)>Geometry 1** right-click **Work Plane 2 (wp2)** and choose **Extrude**.
- 2 In the **Settings** window for **Extrude**, locate the **General** section.
- 3 In the list, select **wp2.c2**.
- 4 Click  **Remove from Selection**.
- 5 Select the object **wp2.c1** only.
- 6 Locate the **Distances** section. In the table, enter the following settings:

Distances (m)
0.1
0.128
0.272
0.325
0.453
0.47
0.542
0.551
0.564

Extrude 3 (ext3)





- 1 In the **Geometry** toolbar, click  **Extrude**.
- 2 In the **Settings** window for **Extrude**, locate the **Distances** section.

3 In the table, enter the following settings:

Distances (m)
0.1
0.325
0.347
0.437
0.453
0.551
0.649
0.73

4 Click the  **Zoom Extents** button in the **Graphics** toolbar.

Work Plane 3 (wp3)

- 1 In the **Geometry** toolbar, click  **Work Plane**.
- 2 In the **Graphics** window toolbar, click  next to  **Select Objects**, then choose **Select Boundaries**.
- 3 Click the  **Click and Hide** button in the **Graphics** toolbar.
- 4 On the object **ext1**, select Boundaries 18, 13, 8, 3, 5, 10, 15, and 20 only.
- 5 Click the  **Click and Hide** button in the **Graphics** toolbar.
- 6 In the **Settings** window for **Work Plane**, locate the **Plane Definition** section.
- 7 From the **Plane type** list, choose **Face parallel**.
- 8 On the object **ext1**, select Boundary 6 only.

Work Plane 3 (wp3)>Plane Geometry

In the **Model Builder** window, click **Plane Geometry**.

Work Plane 3 (wp3)>Polygon 1 (pol1)

- 1 In the **Work Plane** toolbar, click  **Polygon**.
- 2 In the **Settings** window for **Polygon**, locate the **Coordinates** section.
- 3 From the **Data source** list, choose **Vectors**.
- 4 In the **xw** text field, type -117[mm] -137.5[mm] -137.5[mm] -117[mm] -108[mm] -96.5[mm] -96.5[mm] -117[mm].
- 5 In the **yw** text field, type -25[mm] -25[mm] -13.5[mm] -13.5[mm] -4.5[mm] -4.5[mm] -25[mm] -25[mm].

Work Plane 3 (wp3)>Chamfer 1 (cha1)

- 1 In the **Work Plane** toolbar, click  **Chamfer**.
- 2 On the object **pol1**, select Points 2 and 7 only.
- 3 In the **Settings** window for **Chamfer**, locate the **Distance** section.
- 4 In the **Distance from vertex** text field, type 2.5[mm].

Work Plane 3 (wp3)>Polygon 2 (pol2)

- 1 In the **Work Plane** toolbar, click  **Polygon**.
- 2 In the **Settings** window for **Polygon**, locate the **Coordinates** section.
- 3 From the **Data source** list, choose **Vectors**.
- 4 In the **xw** text field, type 136.5[mm] 136.5[mm] 136.5[mm] 131[mm] 131[mm] 121[mm] 121[mm] 113.5[mm] 113.5[mm] 105.5[mm] 105.5[mm] 97.3[mm] 97.3[mm] 90[mm] 90[mm] 80.8[mm] 80.8[mm] 72.4[mm] 72.4[mm] 72.4[mm] 72.4[mm] 60[mm] 60[mm] 55[mm] 55[mm] 45.9[mm] 45.9[mm] 37[mm] 37[mm] 28[mm] 28[mm] 28[mm] 28[mm] 37[mm] 37[mm] 45.9[mm] 45.9[mm] 55[mm] 55[mm] 63.8[mm] 63.8[mm] 72.4[mm] 72.4[mm] 80.8[mm] 80.8[mm] 89[mm] 89[mm] 97.3[mm] 97.3[mm] 105.5[mm] 105.5[mm] 113.5[mm] 113.5[mm] 121[mm] 121[mm] 126[mm] 126[mm] 123.3[mm] 123.3[mm] 123.3[mm] 123.3[mm] 136.5[mm] .
- 5 In the **yw** text field, type -25[mm] -20.5[mm] -20.5[mm] -12.2[mm] -12.2[mm] -4[mm] -4[mm] -0.1[mm] -0.1[mm] 3.3[mm] 3.3[mm] 6[mm] 6[mm] 8[mm] 8[mm] 10.3[mm] 10.3[mm] 12[mm] 12[mm] 12[mm] 12[mm] 14[mm] 14[mm] 15[mm] 15[mm] 15.7[mm] 15.7[mm] 16.8[mm] 16.8[mm] 17.5[mm] 17.5[mm] 12.5[mm] 12.5[mm] 11.8[mm] 11.8[mm] 10.7[mm] 10.7[mm] 10[mm] 10[mm] 8.5[mm] 8.5[mm] 7[mm] 7[mm] 5.3[mm] 5.3[mm] 3.5[mm] 3.5[mm] 1[mm] 1[mm] -1.7[mm] -1.7[mm] -5.1[mm] -5.1[mm] -9[mm] -9[mm] -12.2[mm] -12.2[mm] -20.5[mm] -20.5[mm] -25[mm] -25[mm] -25[mm] .

Work Plane 4 (wp4)

- 1 In the **Model Builder** window, under **Component 1 (comp1)>Geometry 1** right-click **Work Plane 3 (wp3)** and choose **Work Plane**.
- 2 In the **Settings** window for **Work Plane**, locate the **Plane Definition** section.
- 3 From the **Plane** list, choose **yz-plane**.
- 4 From the **Plane type** list, choose **Face parallel**.
- 5 On the object **ext1**, select Boundary 11 only.
- 6 In the tree, select **ext1**.

Work Plane 4 (wp4)>Plane Geometry

In the **Model Builder** window, click **Plane Geometry**.

Work Plane 4 (wp4)>Polygon 1 (pol1)

1 In the **Work Plane** toolbar, click  **Polygon**.

2 In the **Settings** window for **Polygon**, locate the **Coordinates** section.

3 From the **Data source** list, choose **Vectors**.

4 In the **xw** text field, type -137.5[mm] -137.5[mm] -135[mm] -117[mm] -108[mm] -96.5[mm] -90[mm] -81[mm] -69.5[mm] -63[mm] -60.5[mm] -63[mm] -63[mm] -69.5[mm] -69.5[mm] -96.5[mm] -117[mm] -137.5[mm].

5 In the **yw** text field, type -25[mm] -13.5[mm] -13.5[mm] -13.5[mm] -4.5[mm] -4.5[mm] -4.5[mm] 4.5[mm] 4.5[mm] 4.5[mm] 2[mm] -0.5[mm] -3.5[mm] -9[mm] -25[mm] -25[mm] -25[mm] -25[mm].

Work Plane 4 (wp4)>Polygon 2 (pol2)

1 In the **Work Plane** toolbar, click  **Polygon**.

2 In the **Settings** window for **Polygon**, locate the **Coordinates** section.

3 From the **Data source** list, choose **Vectors**.

4 In the **xw** text field, type 136.5[mm] 136.5[mm] 136.5[mm] 131[mm] 131[mm] 121[mm] 121[mm] 113.5[mm] 113.5[mm] 105.5[mm] 105.5[mm] 97.3[mm] 97.3[mm] 90[mm] 90[mm] 80.8[mm] 80.8[mm] 72.4[mm] 72.4[mm] 72.4[mm] 72.4[mm] 60[mm] 60[mm] 55[mm] 55[mm] 45.9[mm] 45.9[mm] 37[mm] 37[mm] 28[mm] 28[mm] 28[mm] 28[mm] 37[mm] 37[mm] 45.9[mm] 45.9[mm] 55[mm] 55[mm] 63.8[mm] 63.8[mm] 72.4[mm] 72.4[mm] 80.8[mm] 80.8[mm] 89[mm] 89[mm] 97.3[mm] 97.3[mm] 105.5[mm] 105.5[mm] 113.5[mm] 113.5[mm] 121[mm] 121[mm] 126[mm] 126[mm] 123.3[mm] 123.3[mm] 123.3[mm] 123.3[mm] 136.5[mm] .

5 In the **yw** text field, type -25[mm] -20.5[mm] -20.5[mm] -12.2[mm] -12.2[mm] -4[mm] -4[mm] -0.1[mm] -0.1[mm] 3.3[mm] 3.3[mm] 6[mm] 6[mm] 8[mm] 8[mm] 10.3[mm] 10.3[mm] 12[mm] 12[mm] 12[mm] 12[mm] 14[mm] 14[mm] 15[mm] 15[mm] 15.7[mm] 15.7[mm] 16.8[mm] 16.8[mm] 17.5[mm] 17.5[mm] 12.5[mm] 12.5[mm] 11.8[mm] 11.8[mm] 10.7[mm] 10.7[mm] 10[mm] 10[mm] 8.5[mm] 8.5[mm] 7[mm] 7[mm] 5.3[mm] 5.3[mm] 3.5[mm] 3.5[mm] 1[mm] 1[mm] -1.7[mm] -1.7[mm] -5.1[mm] -5.1[mm] -9[mm] -9[mm] -12.2[mm] -12.2[mm] -20.5[mm] -20.5[mm] -25[mm] -25[mm] -25[mm] .

Copy 1 (copy1)

1 In the **Model Builder** window, right-click **Geometry 1** and choose **Transforms>Copy**.

- 2 Select the object **wp4** only.
- 3 In the **Settings** window for **Copy**, locate the **Displacement** section.
- 4 In the **x** text field, type 0.098.

Copy 2 (copy2)

- 1 In the **Geometry** toolbar, click  **Transforms** and choose **Copy**.
- 2 Select the object **wp4** only.
- 3 In the **Settings** window for **Copy**, locate the **Displacement** section.
- 4 In the **x** text field, type 2*0.098.

Delete Entities 1 (dell)

- 1 Right-click **Geometry 1** and choose **Delete Entities**.
- 2 On the object **copy2**, select Boundary 2 only.
- 3 In the **Settings** window for **Delete Entities**, click  **Build All Objects**.



Union 1 (uni1)

- 1 In the **Geometry** toolbar, click  **Booleans and Partitions** and choose **Union**.
- 2 Select the objects **ext2** and **ext3** only.
- 3 In the **Settings** window for **Union**, locate the **Union** section.
- 4 Clear the **Keep interior boundaries** check box.

Union 2 (uni2)

- 1 In the **Geometry** toolbar, click  **Booleans and Partitions** and choose **Union**.
- 2 Select the objects **copy1**, **dell**, **ext1**, **wp3**, and **wp4** only.

Difference 1 (dif1)

- 1 In the **Geometry** toolbar, click  **Booleans and Partitions** and choose **Difference**.
- 2 Select the object **uni2** only.
- 3 In the **Settings** window for **Difference**, locate the **Difference** section.
- 4 Select the **Keep objects to subtract** check box.
- 5 Find the **Objects to subtract** subsection. Click to select the  **Activate Selection** toggle button.
- 6 Select the object **uni1** only.
- 7 Click  **Build Selected**.

Form Union (fin)

- 1 In the **Model Builder** window, click **Form Union (fin)**.

- 2 In the **Settings** window for **Form Union/Assembly**, click  **Build Selected**.

Inlet

- 1 In the **Geometry** toolbar, click  **Selections** and choose **Explicit Selection**.

This section asks you to define a number of boundary selections to use when setting up the physics. To make it easier to select the correct boundaries, you will open the Selection List, where all boundaries are available by numbers. When making your selections, you can Ctrl-click in this list to select several boundaries at once, and use the plus button on the Settings tab to add them to your selection. Note that when working on your own models, it is usually more convenient to make selections by clicking in the geometry.

- 2 In the **Settings** window for **Explicit Selection**, type Inlet in the **Label** text field.
- 3 Locate the **Entities to Select** section. From the **Geometric entity level** list, choose **Boundary**.
- 4 On the object **fin**, select Boundary 6 only.

Outlet

- 1 In the **Geometry** toolbar, click  **Selections** and choose **Explicit Selection**.
- 2 In the **Settings** window for **Explicit Selection**, type Outlet in the **Label** text field.
- 3 Locate the **Entities to Select** section. From the **Geometric entity level** list, choose **Boundary**.
- 4 On the object **fin**, select Boundary 1 only.

Pipe Perforates

- 1 In the **Geometry** toolbar, click  **Selections** and choose **Explicit Selection**.
- 2 In the **Settings** window for **Explicit Selection**, type Pipe Perforates in the **Label** text field.
- 3 Locate the **Entities to Select** section. From the **Geometric entity level** list, choose **Boundary**.
- 4 On the object **fin**, select Boundaries 50, 52, 74, and 76 only.

Pipe Perforate with Sleeve

- 1 In the **Geometry** toolbar, click  **Selections** and choose **Explicit Selection**.
- 2 In the **Settings** window for **Explicit Selection**, type Pipe Perforate with Sleeve in the **Label** text field.
- 3 Locate the **Entities to Select** section. From the **Geometric entity level** list, choose **Boundary**.

- 4 On the object **fin**, select Boundaries 26 and 28 only.

Inlet Baffle Perforates

- 1 In the **Geometry** toolbar, click  **Selections** and choose **Explicit Selection**.
- 2 In the **Settings** window for **Explicit Selection**, type Inlet Baffle Perforates in the **Label** text field.
- 3 Locate the **Entities to Select** section. From the **Geometric entity level** list, choose **Boundary**.
- 4 On the object **fin**, select Boundaries 43, 67, and 91 only.

Outlet Baffle Perforates

- 1 In the **Geometry** toolbar, click  **Selections** and choose **Explicit Selection**.
- 2 In the **Settings** window for **Explicit Selection**, type Outlet Baffle Perforates in the **Label** text field.
- 3 Locate the **Entities to Select** section. From the **Geometric entity level** list, choose **Boundary**.
- 4 On the object **fin**, select Boundaries 36, 60, 84, and 101 only.

Pipe Ends

- 1 In the **Geometry** toolbar, click  **Selections** and choose **Explicit Selection**.
- 2 In the **Settings** window for **Explicit Selection**, type Pipe Ends in the **Label** text field.
- 3 Locate the **Entities to Select** section. From the **Geometric entity level** list, choose **Boundary**.
- 4 On the object **fin**, select Boundaries 97 and 108 only.

Geometry

- 1 In the **Geometry** toolbar, click  **Selections** and choose **Explicit Selection**.
- 2 In the **Settings** window for **Explicit Selection**, type Geometry in the **Label** text field.
- 3 Locate the **Entities to Select** section. From the **Geometric entity level** list, choose **Object**.
- 4 Select the object **fin** only.

Walls

- 1 In the **Geometry** toolbar, click  **Selections** and choose **Adjacent Selection**.
- 2 In the **Settings** window for **Adjacent Selection**, locate the **Input Entities** section.
- 3 Click **+ Add**.
- 4 In the **Add** dialog box, select **Geometry** in the **Input selections** list.
- 5 Click **OK**.

- 6 In the **Settings** window for **Adjacent Selection**, locate the **Output Entities** section.
- 7 Clear the **Exterior boundaries** check box.
- 8 Select the **Interior boundaries** check box.
- 9 In the **Label** text field, type Walls.

Interior Hard Walls

- 1 In the **Geometry** toolbar, click  **Selections** and choose **Difference Selection**.
- 2 In the **Settings** window for **Difference Selection**, locate the **Geometric Entity Level** section.
- 3 From the **Level** list, choose **Boundary**.
- 4 Locate the **Input Entities** section. Click **+ Add**.
- 5 In the **Add** dialog box, select **Walls** in the **Selections to add** list.
- 6 Click **OK**.
- 7 In the **Settings** window for **Difference Selection**, locate the **Input Entities** section.
- 8 Click **+ Add**.
- 9 In the **Add** dialog box, in the **Selections to subtract** list, choose **Pipe Perforates**, **Pipe Perforate with Sleeve**, **Inlet Baffle Perforates**, **Outlet Baffle Perforates**, and **Pipe Ends**.
- 10 Click **OK**.
- 11 In the **Settings** window for **Difference Selection**, type Interior Hard Walls in the **Label** text field.

Symmetry

- 1 In the **Geometry** toolbar, click  **Selections** and choose **Box Selection**.
- 2 In the **Settings** window for **Box Selection**, type Symmetry in the **Label** text field.
- 3 Locate the **Geometric Entity Level** section. From the **Level** list, choose **Boundary**.
- 4 Locate the **Box Limits** section. In the **z maximum** text field, type 0.01.
- 5 Locate the **Output Entities** section. From the **Include entity if** list, choose **Entity inside box**.

Form Union (fin)

I Click the  **Wireframe Rendering** button in the **Graphics** toolbar.

The finalized geometry should look like the figure below using **Wireframe Rendering**.

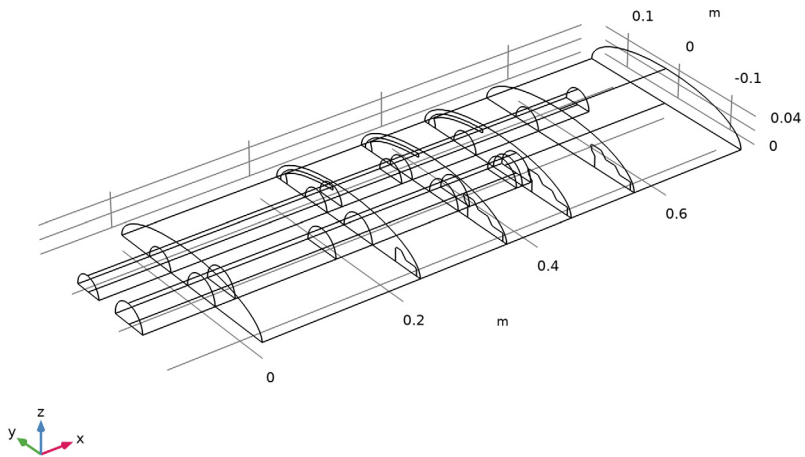

2 Click the  **Wireframe Rendering** button in the **Graphics** toolbar.

Switching back to solid rendering, the geometry should look like the image below.

