

INTRODUCTION TO
LiveLink™ *for* Revit®

Introduction to LiveLink™ for Revit®

© 2014–2022 COMSOL

Protected by patents listed on www.comsol.com/patents, or see Help>About COMSOL Multiphysics on the File menu in the COMSOL Desktop for a less detailed lists of U.S. Patents that may apply. Patents pending.

This Documentation and the Programs described herein are furnished under the COMSOL Software License Agreement (www.comsol.com/comsol-license-agreement) and may be used or copied only under the terms of the license agreement. LiveLink™ for Revit® is not affiliated with, endorsed by, sponsored by, or supported by Autodesk, Inc., and/or its affiliates and/or subsidiaries. Portions of this software are owned by Siemens Product Lifecycle Management Software Inc. © 1986–2022. All Rights Reserved. Portions of this software are owned by Spatial Corp. © 1989–2022. All Rights Reserved.

COMSOL, the COMSOL logo, COMSOL Multiphysics, COMSOL Desktop, COMSOL Compiler, COMSOL Server, and LiveLink are either registered trademarks or trademarks of COMSOL AB. ACIS and SAT are registered trademarks of Spatial Corporation. Autodesk and Revit are registered trademarks or trademarks of Autodesk, Inc., and/or its subsidiaries and/or affiliates in the USA and/or other countries. CATIA is a registered trademark of Dassault Systèmes or its subsidiaries in the US and/or other countries. Parasolid is a trademark or registered trademark of Siemens Product Lifecycle Management Software Inc. or its subsidiaries in the United States and in other countries. All other trademarks are the property of their respective owners, and COMSOL AB and its subsidiaries and products are not affiliated with, endorsed by, sponsored by, or supported by those or the above non-COMSOL trademark owners. For a list of such trademark owners, see www.comsol.com/trademarks.

Version: COMSOL 6.1

Contact Information

Visit the Contact COMSOL page at www.comsol.com/contact to submit general inquiries or search for an address and phone number. You can also visit the Worldwide Sales Offices page at www.comsol.com/contact/offices for address and contact information.

If you need to contact Support, an online request form is located on the COMSOL Access page at www.comsol.com/support/case. Other useful links include:

- Support Center: www.comsol.com/support
- Product Download: www.comsol.com/product-download
- Product Updates: www.comsol.com/support/updates
- COMSOL Blog: www.comsol.com/blogs
- Discussion Forum: www.comsol.com/forum
- Events: www.comsol.com/events
- COMSOL Video Gallery: www.comsol.com/videos
- Support Knowledge Base: www.comsol.com/support/knowledgebase

Part number: CM024502

Contents

Introduction	5
Synchronizing the Geometry	6
About CAD File Formats	21
Removing Small Geometric Entities with Repair	23
Removing Small Geometric Entities with the Defeaturing Tools	32
Removing Small Geometric Entities with Remove Details	41
Creating a Fluid Domain Inside a Solid Structure	49

Introduction

This guide introduces you to LiveLink™ *for* Revit®, which provides two possibilities for applying multiphysics analysis in the development of your designs. To begin with, you can synchronize geometries between Revit® Architecture and the COMSOL Desktop® when running them side-by-side. In addition, the product adds support for importing several 3D CAD file formats into your COMSOL models.

Regardless of the way you bring CAD designs into COMSOL, with LiveLink™ you have a robust platform, including repair and defeaturing tools, to prepare the geometry for multiphysics modeling. The detailed tutorials that follow start you off with becoming efficient in using the provided functionality.

Synchronizing the Geometry

The synchronization of geometry between Revit® Architecture and COMSOL is associative, and can be configured to generate selections in the COMSOL model for elements in the Revit project. The selections are available for setting up the analysis, for example for physics interface or mesh settings. Working with selections also retains the model settings should you change the design in Revit and resynchronize.

This tutorial gives a quick introduction to the workflow when synchronizing the geometry of a room, and preparing it for analysis. Although setting up the physics interface is not part of the tutorial, the geometry that is generated can be used for acoustics simulation of the room, for example.

The following steps are included in the exercise:

- Configuring the synchronization of the Revit project
- Creating a COMSOL model containing a LiveLink node
- Synchronizing the geometry
- Preparing the synchronized geometry for analysis

Configuring the Synchronization

1 In Revit Architecture open the file `house.rvt`, which is found in your COMSOL installation directory, under the folder `applications/LiveLink_for_Revit/Tutorials,_LiveLink_Interface`.

The example house project contains several rooms. In the following you set up the synchronization of the living room together with the elements within the room.

2 In the Revit Project Browser double click the Floor Plans > Level 1 view to switch to that view.

3 On the COMSOL Multiphysics tab click Synchronization Settings.

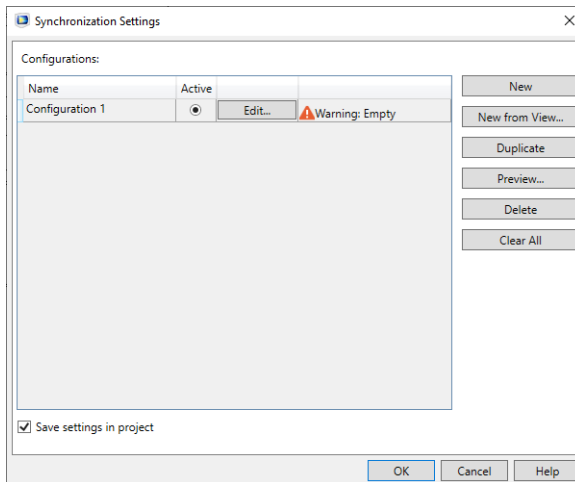

When you open the Synchronization Settings dialog box for the first time in a project an empty synchronization configuration is automatically added to the Configurations table. To enable synchronization of the project there needs to be at least one configuration with content.

4 Double-click Configuration 1, in the Name column, then edit the text to change the name to Living room.

5 Click the Edit button to open the Settings dialog box for the Living room configuration.

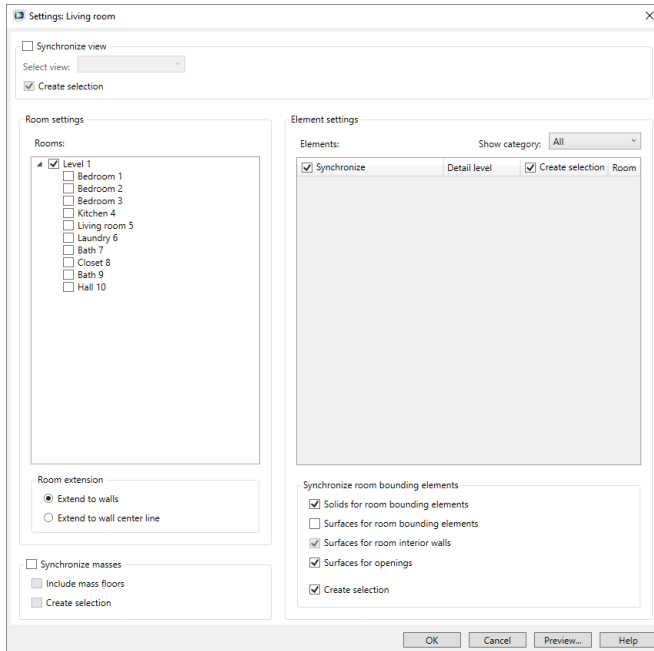

The Rooms list to the left contains the rooms defined in the project. To include the geometry of a room in the synchronization select its check box.

6 Select the Living room 5 check box.

According to the default setting in the Room extension section, the solid object generated for the room volume extends to the walls, and from the floor to the roof or ceiling.

The elements belonging to selected rooms are automatically displayed in the Elements table.

Elements: Show category: All

<input checked="" type="checkbox"/> Synchronize	Detail level	<input checked="" type="checkbox"/> Create selection	Room
<input checked="" type="checkbox"/> Furniture			
<input type="checkbox"/> MSofa-Pensi: 2134mm	BoundingBox	<input type="checkbox"/>	Living room 5
<input type="checkbox"/> MSofa-Pensi: 2134mm	BoundingBox	<input type="checkbox"/>	Living room 5
<input type="checkbox"/> MTable-End: 0762 x 0762mm	BoundingBox	<input type="checkbox"/>	Living room 5
<input type="checkbox"/> MTable-Coffee: 0915 x 1830	BoundingBox	<input type="checkbox"/>	Living room 5
<input type="checkbox"/> MEntertainment center: 183	BoundingBox	<input type="checkbox"/>	Living room 5
<input type="checkbox"/> MTV Stand: M_TV Stand	BoundingBox	<input type="checkbox"/>	Living room 5
<input type="checkbox"/> MTV - Flat Screen: 1270mm	BoundingBox	<input type="checkbox"/>	Living room 5
<input type="checkbox"/> Floorstanding Speaker: Floo	BoundingBox	<input type="checkbox"/>	Living room 5
<input type="checkbox"/> Floorstanding Speaker: Floo	BoundingBox	<input type="checkbox"/>	Living room 5
<input checked="" type="checkbox"/> Doors			
<input type="checkbox"/> MDouble-Glass 2: 1830 x 21	BoundingBox	<input type="checkbox"/>	Living room 5
<input checked="" type="checkbox"/> Windows			
<input type="checkbox"/> MSkylight: 0610 x 0686mm	BoundingBox	<input type="checkbox"/>	Living room 5
<input type="checkbox"/> MSkylight: 0610 x 0686mm	BoundingBox	<input type="checkbox"/>	Living room 5
<input type="checkbox"/> MCasement Dbl with Trim: 1	BoundingBox	<input type="checkbox"/>	Living room 5
<input type="checkbox"/> MCasement Dbl with Trim: 1	BoundingBox	<input type="checkbox"/>	Living room 5

Here you select the elements to include in the synchronization, and their geometrical representation (Detail level), for which two choices are available:

- **Bounding Box:** The enclosing box of the element is generated for transfer during synchronization. Choosing this option makes it possible to use the drawing tools in COMSOL to create a new, simplified, geometry for elements that are not suitable for simulation.
- **Original:** The geometry of the element is transferred as is during synchronization. Choosing this option may require removal of small details from the geometry by using the defeaturing tools in COMSOL.

There is also a choice in the table for creating a selection for the element in the COMSOL model during synchronization.

- 7** To synchronize all elements belonging to the Furniture category right-click somewhere in the Elements table, then from the context menu select Synchronize>Select all>Category>Furniture. The check boxes for the individual furniture elements become selected.

8 Right-click again in the table, then from the menu select Create selection>Select all>Category>Furniture. The check boxes for the individual furniture elements in the Create selection column become selected.

Finally, change the element representation to the original geometry for all furniture elements.

9 Right-click in the table, then from the menu select Detail level>Original>Select all>Category>Furniture.

The synchronization of solids for the room bounding elements, such as the walls, roofs, and floors is turned on by default in the Synchronize room bounding elements section. Here you also see that surfaces are going to be generated for openings such as doors and windows. These elements are useful due to the associated selections that can be used in the model set up after synchronization.

10 Click OK to confirm the settings and close the Settings dialog box for the Living room.

In the Synchronization Settings dialog box the Living room configuration is no longer empty, and can be used for synchronization.

11 Click OK to close the Synchronization Settings dialog box.

Starting a COMSOL Model



1 Switch to the COMSOL Desktop and create a new model.

Note that the project in Revit needs to remain open for the synchronization to work.

2 In the New window click Blank Model to skip the steps of selecting physics interfaces and study type.

3 On the Home toolbar, click Add Component  and choose 3D.

Adding a LiveLink Node to the Geometry

1 On the Home toolbar, click LiveLink  then select LiveLink for Revit .

2 In the Settings window click Synchronize.

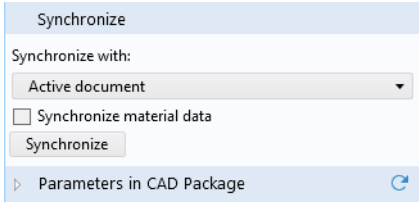

If the Revit window is hidden behind other windows on your desktop the Start Synchronization dialog box may appear. If this happens, click OK to bring Revit to the front and start the synchronization. Since Revit only allows for the computations of the room geometry to start if a floor plan or section view is active, you may also have to switch to the Level 1 floor plan view in case the synchronization does not start.

During synchronization the geometry for the living room and the selected elements is generated in Revit and transferred to the COMSOL model.

3 On the Graphics toolbar click Wireframe Rendering .

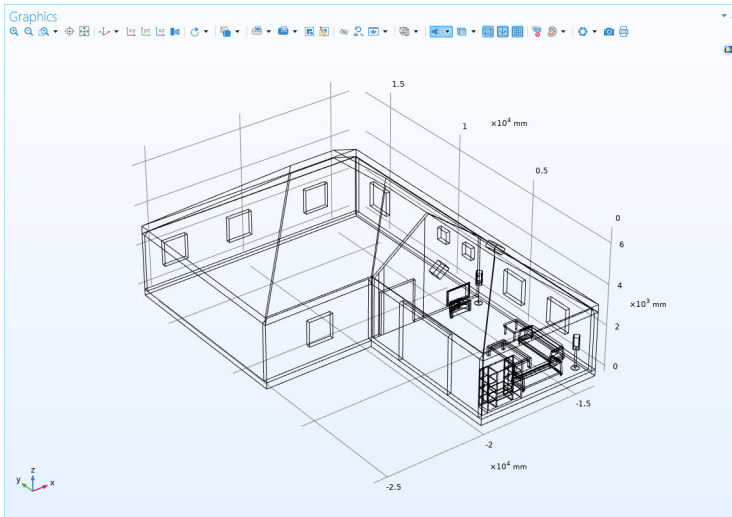

4 In the Settings window, expand the Object Selections section.

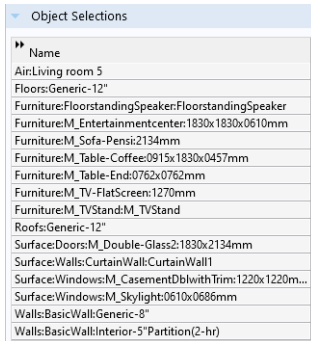



Name
Air:Living room 5
Floors:Generic-12"
Furniture:FloorstandingSpeaker:FloorstandingSpeaker
Furniture:M_Entertainmentcenter:1830x1830x0610mm
Furniture:M_Sofa-Pensi:2134mm
Furniture:M_Table-Coffee:0915x1830x0457mm
Furniture:M_Table-End:0762x0762mm
Furniture:M_TV-FlatScreen:1270mm
Furniture:M_TVStand:M_TVStand
Roofs:Generic-12"
Surface:Doors:M_Double-Glass2:1830x2134mm
Surface:Walls:CurtainWall:CurtainWall1
Surface:Windows:M_CasementDblwithTrim:1220x1220m...
Surface:Windows:M_Skylight:0610x0686mm
Walls:BasicWall:Generic-8"
Walls:BasicWall:Interior-5"Partition(2-hr)

These selections are on the object level, and clicking on a selection in the table highlights the corresponding objects in the Graphics window. The selections are available for input to operations and settings during all stages of the model setup. Read more about how to work with selections in the *COMSOL Multiphysics Reference Manual*.

Working with Selections

Start with creating union selections to be used as inputs to the geometry operations that will create the final geometry for the simulation.

SELECTION FOR THE ROOM BOUNDING ELEMENTS

- 1 From the Geometry toolbar click Selections  and choose Union Selection .
- 2 In the Settings window for Union Selection, in the Label field, enter Room Bounding Solids.
- 3 From the Level list select Object.
- 4 Click the Add  button under the Selections to add table.



- 5 From the Add dialog box select the selections shown in the table below:

SELECTIONS TO ADD
Floors:Generic-12"
Roofs:Generic-12"
Walls:BasicWall:Generic-8"
Walls:BasicWall:Interior-5"Partition(2-hr)

To select several selections you can hold down the Ctrl button while clicking on the selections.

- 6 Click OK to close the Add dialog box.



SELECTION FOR THE ROOM

- 1 From the Geometry toolbar click Selections  and choose Union Selection .
- 2 In the Settings window for Union Selection, in the Label field, enter Room.
- 3 From the Level list select Object.
- 4 Click the Add  button under the Selections to add table.
- 5 From the Add dialog box select the selections shown in the table below:

SELECTIONS TO ADD
Air:Living room 5
Surface:Doors:M_Double-Glass2:1830x2134mm
Surface:Walls:CurtainWall:CurtainWall1
Surface:Windows:M_CasementDblwithTrim:1220x1220mm
Surface:Windows:M_Skylight:0610x0686mm
Room Bounding Solids

- 6 Click OK to close the Add dialog box.

SELECTION FOR THE FURNITURE

- 1 From the Geometry toolbar click Selections  and choose Union Selection .
- 2 In the Settings window for Union Selection, in the Label field, enter Furniture.
- 3 From the Level list select Object.
- 4 Click the Add  button under the Selections to add table.

- 5 From the Add dialog box select all the selections for the furniture as shown below:



SELECTIONS TO ADD
Furniture:FloorstandingSpeaker:FloorstandingSpeaker
Furniture:M_Entertainmentcenter:1830x1830x0610mm
Furniture:M_Sofa-Pensi:2134mm
Furniture:M_Table-Coffee:0915x1830x0457mm
Furniture:M_Table-End:0762x0762mm
Furniture:M_TV-FlatScreen:1270mm
Furniture:M_TVStand:M_TVStand

- 6 Click OK to close the Add dialog box.

Creating the Computational Domain

CONVERTING TO A SINGLE SOLID

To be able to use the objects in the defined selections in the model set-up, they need to become part of the final geometry. To incorporate all objects into a single solid object use the Convert to Solid geometry operation.

- 1 From the Geometry toolbar click Conversions  and choose Convert to Solid .
- 2 In the Settings window for Convert to Solid, from the Input objects list select Room.
- 3 From the Repair tolerance list select Relative, and check that the Relative repair tolerance is set to 1E-6.
- 4 Click Build All Objects .

DELETING ENTITIES

Since only the room volume is needed at the end, delete the domains for the walls, roof and floor.

- 1 On the Geometry toolbar click Delete .
- 2 In the Settings window for Delete Entities, from the Geometric entity level list, select Domain.
- 3 From the Selection list select Room Bounding Solids.

- 4 Click Build All Objects .

The next step is to delete the solid objects for the handles and the doors for the bookshelf in the room. The small details on these are not needed for the simulation. You will generate a new surface in place of the doors further ahead.

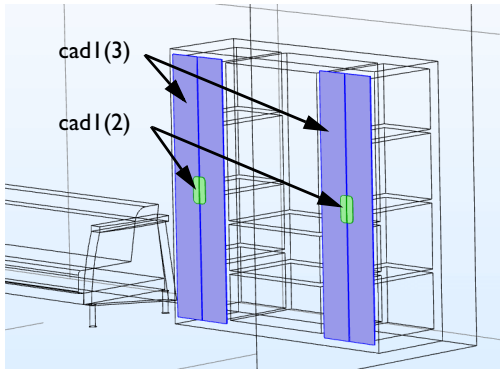

- 5 On the Geometry toolbar click Delete .
- 6 In the Settings window for Delete Entities, from the Geometric entity level list, select Object.
- 7 In the Graphics window select the two objects highlighted in the figure below.



- 8 Click Build All Objects .



COMPUTING THE DIFFERENCE OF THE ROOM AND FURNITURE

The last step before obtaining the computational volume is to subtract the objects for the furniture from the object for the room.

- 1 On the Geometry toolbar click Booleans and Partitions  and choose Difference .
- 2 In the Settings window for Difference, from the Objects to add list select Room.
- 3 Click the Activate button under Objects to subtract.
- 4 From the Objects to subtract list select Furniture.
- 5 Click Build All Objects .

The solid for the room volume is now ready. Before meshing however, remove small features that remain in the geometry by using the defeaturing tools.

Defeaturing the Geometry

- 1 On the Geometry toolbar click Defeaturing and Repair  and choose Delete Sliver Faces .
- 2 In the Maximum face width text field enter 5 [mm].
- 3 Click Find Sliver Faces.
The 18 sliver faces that are detected are displayed in the Sliver face selection list.
- 4 Select for example Sliver face 8 from the list, then click Zoom Selected  next to the list to find the face in the Graphics window.

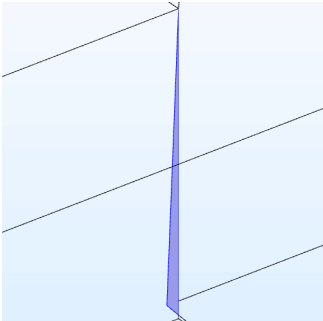

A sliver face is a face with a high aspect ratio. If it is not removed from the geometry it may cause problems during meshing. Remaining sliver faces in the list are located on the bezel of the flat screen TV, and some other on the two couches.

- 5 To remove the sliver faces click the Delete All button below the list.
Continue with deleting some larger faces to further simplify the geometry, and also to create new faces on the front of the bookshelf.
- 6 From the toolbar in the Settings window for Delete Sliver Faces click the Delete Faces  button.
- 7 Check that Activate Selection is selected next to the Faces to delete list before continuing to the next step.
The Delete Faces tool can delete faces from an object, and cover the resulting wound by growing (or shrinking) adjacent faces.

- 8 First, select, on both couches, the faces that are highlighted in the figure below. There are 5 faces located on the back and bottom of each couch.

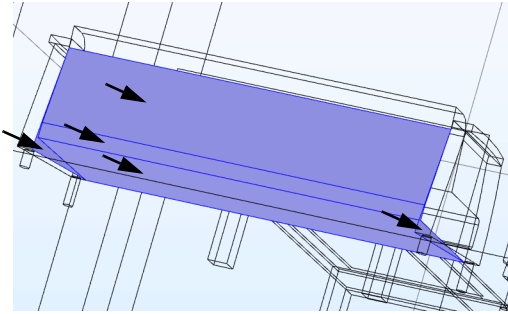

- 9 Continue with selecting the highlighted faces on the sides of each armrest on the couches. There are 4 faces on each couch.

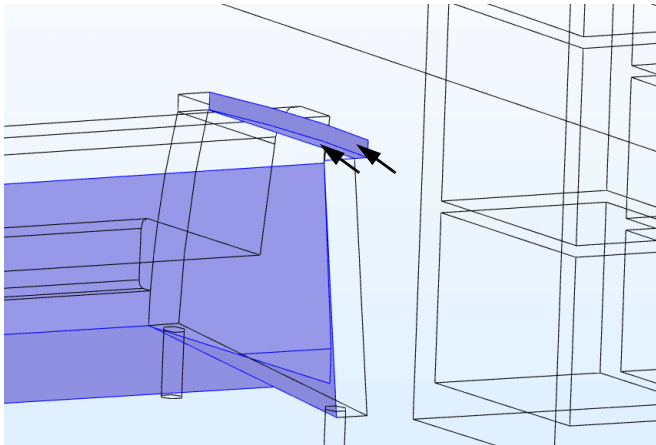

- 10** Finally select the highlighted faces on both sides of the bookshelf. There are 5 faces for each shelf.

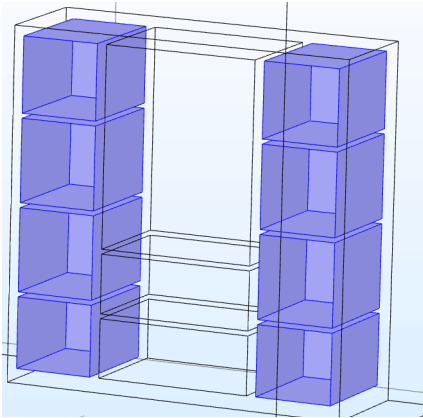

- 11** Click Delete Selected.

The last step before meshing is to find and delete spikes that still remain in the geometry. Similarly to a sliver face, a spike is a region in a face that has a high aspect ratio.

- 12** From the toolbar in the Settings window for Delete Faces click the Delete Spikes  button.

- 13** In the Maximum spike width text field enter 10[mm].

- 14** Click the Find Spikes button.

- 15** The tool detected 4 spikes. Select Spike 4 and click Zoom Selected  to zoom in on the edges that comprise the spike.

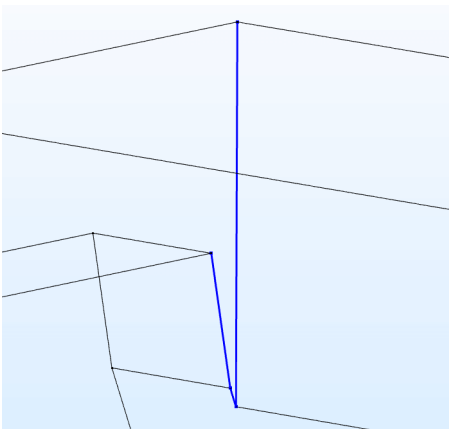



- 16** Click Delete All to remove all spikes.

17 To restore the default view click Go to Default 3D View  on the Graphics toolbar.

Meshing the Geometry

The following steps show how to create an unstructured tetrahedral mesh for the geometry using custom mesh size parameters on the faces for the furniture in the room. A mesh suitable for a simulation may be different from the one generated by following the steps below.

- 1 On the Mesh toolbar click Free Tetrahedral .
- 2 On the Mesh toolbar click Normal  to add a Size attribute to the Free Tetrahedral 1 node.
- 3 In the Settings window for Size select Boundary from the Geometric entity level list.
- 4 Expand the Selection list.

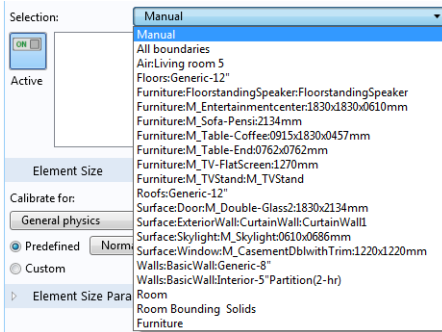

The list of available selections includes the boundaries for the room bounding and furniture elements that were synchronized from the Revit project. The union selections created earlier in model are also available. In this case assume that to resolve the smaller boundaries of the furniture the Size 1 attribute node should apply to the Furniture selection.

5 From the Selection list select Furniture.

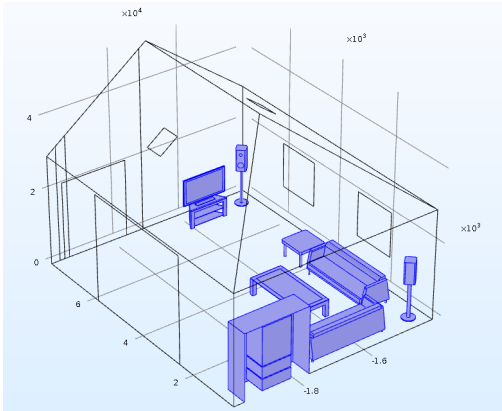

6 Click the Custom radio button.

This allows the individual tuning of the mesh parameters. Change the maximum and minimum element size to more suitable values.

7 In the Element Size Parameters section select the Maximum element size check box and enter 100[mm].

8 Select the Minimum element size check box and enter 20[mm].

9 Click Build All .

10 To get the view below click the Click and Hide  button on the Graphics toolbar, then click on the boundaries that obstruct the view to hide them. When done, click Hide and Select again to activate selection, instead of hiding, when clicking on the geometric entities.

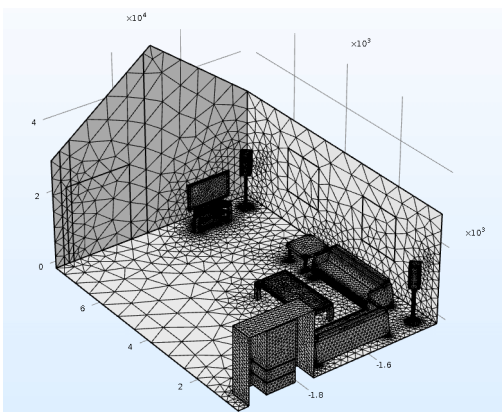

About CAD File Formats

To better understand the file import related functionality of Revit[®], first review some general background information about CAD file formats.

CAD Software, Geometry Kernels, and File Formats

Each CAD program uses a geometry kernel to create a mathematical description of the objects and to calculate the results of solid-modeling operations. Parasolid[®] and ACIS[®] are the two most common kernels, and many CAD programs license these kernels. In addition, some programs use their own kernel (as does COMSOL). Each of these kernels has a native file format associated with it. For example, the Parasolid file format is simply called Parasolid, and the one from ACIS is called ACIS or SAT[®].

The geometry kernel defines the type of internal representations used for 3D modeling, which can vary considerably among different kernels. That explains why the representations stored in the various file formats are also very different. Revit[®] can read several of these different descriptions of objects and translate them into a format that COMSOL can work with.

In addition to the file formats that are native to a geometry kernel, yet other formats are based on neutral standards that were defined to ease the exchange of geometric models among CAD software applications. STEP and IGES are the two most popular such formats.

Yet another class of files use surface-mesh geometry formats. They do not represent a model's exact 3D geometry; instead, they store only triangular meshes of the surfaces. The most common examples of these types of formats are STL and 3MF.

Translating 3D CAD Files Between Formats

Geometric models do not always pass flawlessly between different file formats due to the fact that they are represented differently. This means that the quality of a translation when importing a file to COMSOL depends on the file format. The smoothest way is to use the native format of your CAD system. If this is not an option, we in general recommend that you use Parasolid, STEP, or ACIS.

Importing 3D CAD files into COMSOL is straightforward. Since the settings of the import operation have been tuned to suit the most common cases, the

majority of files import simply with the click of a button. During import the geometry is checked for errors and automatically repaired. The repair operation also removes small features that fall within the import tolerance.

Removing Small Geometric Entities with Repair

In this example, the Parasolid® file of a wheel rim contains a few small details, which are not removed during import, since they fall outside the default import tolerance. The step-by-step instructions below demonstrate one way to locate and remove these features. The general workflow is:

- Import the file
- Create a mesh for quick examination of the geometry
- Measure the size of the features you would like to remove
- Repair the object
- Create a new mesh for comparison

Model Wizard

- 1 Start COMSOL Multiphysics.
- 2 Select Blank Model to skip the steps of selecting physics interfaces and study type.
- 3 On the Home toolbar, click Add Component  and select 3D.

Importing the Geometry

The wheel rim geometry for this tutorial has been saved in the Parasolid format. Make sure that the CAD Import Module geometry kernel is used.

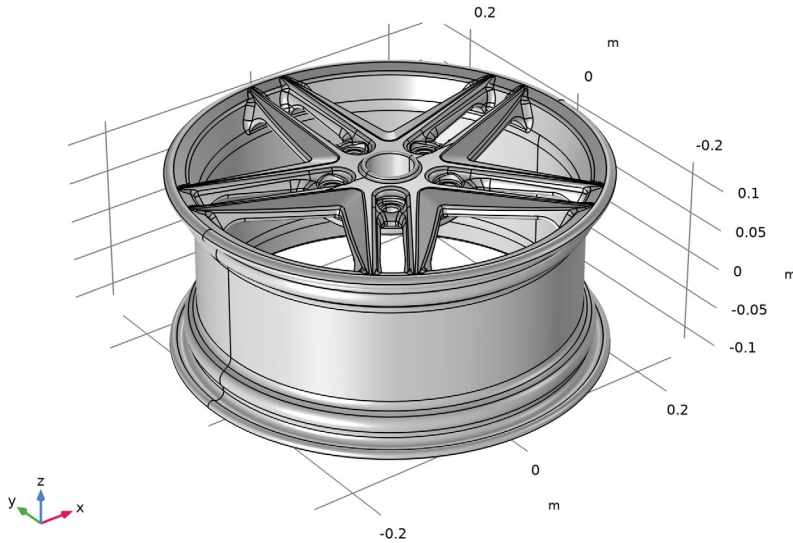

- 1 In the Model Builder window, under Component 1 (comp1) click Geometry 1.
- 2 In the Settings window for Geometry, from the Geometry representation list, choose CAD kernel.
- 3 On the Home toolbar click Import .
- 4 In the Settings window for Import click the Browse button.
- 5 In your COMSOL installation directory navigate to the folder `applications/LiveLink_for_Revit/Tutorials,_CAD_Import` and double click the file `wheel_rim.x_b`.
- 6 Click Import.

As soon as the import is done the geometry appears in the Graphics window.



Creating a Surface Mesh

Creating a mesh for an imported solid is often the fastest way to assess the quality of the geometry and to identify regions needing repair or defeaturing. For more complex objects with many details you can save some time initially by creating a surface mesh only.

- 1 In the Mesh toolbar click Boundary  and choose Free Triangular .
- 2 Go to the Settings window for Free Triangular and from the Selection list box choose All boundaries.
- 3 Click the Build All  button to create the mesh.

As soon as the mesh is ready the Messages window displays the number of mesh elements, which is about 33,000.

Two Information nodes appear under the Free Triangular 1 node in the mesh sequence. These information messages indicate that the geometry contains edges that are much shorter than the minimum element size, and that there are faces that are smaller than the minimum element size. These nodes contain a list of entities, in this case short edges and small faces, causing problems. These entities are also highlighted in the geometry, and are usually surrounded by a

denser mesh that indicates faces or edges significantly smaller than the geometry.

- 4 Click the Information 1 node in the meshing sequence, then in the Graphics window zoom in on the area around the bolt holes, shown below.

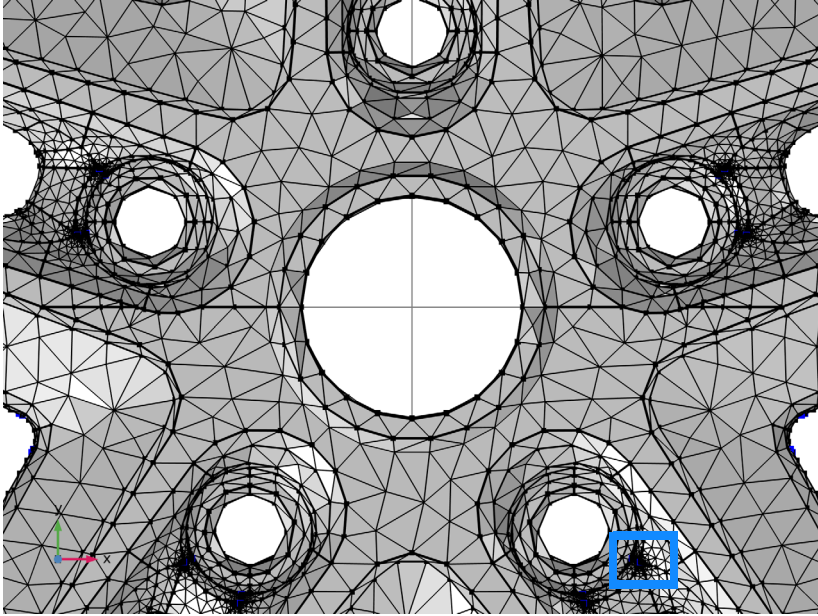

The areas of dense mesh close to each bolt hole are due to slivers and small faces.

- 5 Zoom in to the region indicated by the blue rectangle, and click the Mesh Rendering  button in the Graphics toolbar for a better view of these small geometric entities.

The small triangular face and adjacent sliver face can be found in two places around each bolt hole location. The highlighted edges are listed in the Selection list of the Information node.

To get a representative size for these faces measure the length of one of its edges, number 1384 in the list, which is highlighted by the arrow in the figure to the right.

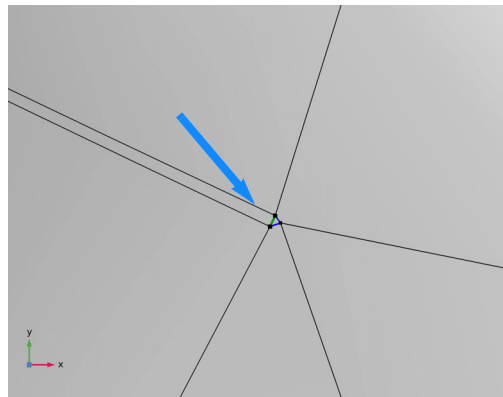

6 Scroll down in the Selection list inside the Settings window for Information 1, then click edge 1384.

7 In the Mesh toolbar, click Measure .

The Messages window displays the length of the edge, which is 5.4193×10^{-5} m — that is, $5.4193 \cdot 10^{-5}$ m or about 0.002 inches.

Now take a closer look at some of the other short edges listed in the Information node.

8 Scroll further down in the Selection list inside the Settings window for Information 1, then click edge 1813.

9 Click the Zoom to selection  button next to the list.

The Graphics window centers and zooms in on the highlighted edge.

10 Using the mouse zoom out and pan to find where the edge is located on the wheel rim. It forms one side of a sliver face located in the region where two adjacent spokes connect to the rim.

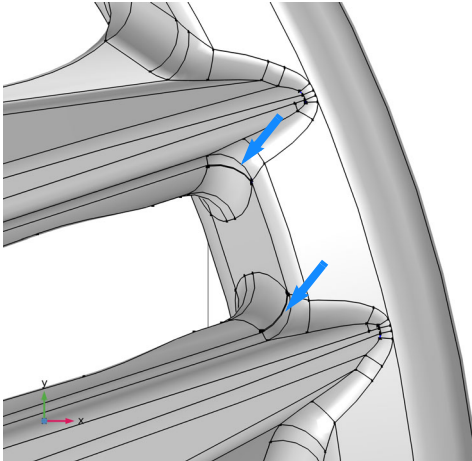



Each spoke contains a similar sliver indicated by the arrows in the figure.

11 To get the width of the sliver face, click Measure  in the Mesh toolbar, while the edge is still highlighted in the list.

The length for edge 1813 is $3.126 \cdot 10^{-4}$ m (about 0.012 inches).

Repairing the Geometry

Now that you know the size of the faces to be removed you can repair the geometry.

- 1 In the Geometry toolbar click Defeaturing and Repair  and choose Repair .
- 2 In the Graphics window select the wheel rim to add it to the Input objects list.
- 3 In the Absolute repair tolerance text field enter $3.2e-4$.

Absolute repair tolerance:
 m

By keeping the repair tolerance close to the size of the features to be removed you can avoid removing anything else and breaking the geometry.
- 4 Click Build All Objects  to perform the operation.
- 5 Examine the geometry. Pan and zoom to take a look at the areas that contained the slivers and small faces, which are no longer present in the geometry.

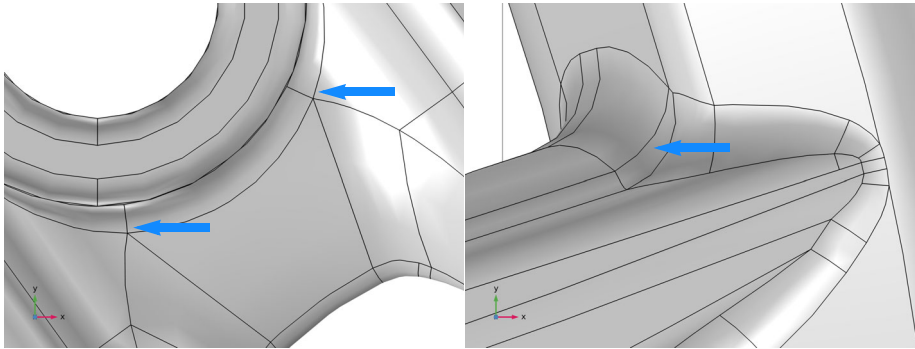

The small faces and slivers are no longer present in the geometry. According to the Information section in the Settings window for Repair, 60 short edges and 20 sliver faces were removed.

Updating the Mesh and Continuing with the Repair

- 1 In the Home toolbar, click Build Mesh .

This time the mesh contains about 5000 surface elements less than before the repair. The Information 1 node informs that some edges are still shorter than the minimum element size.

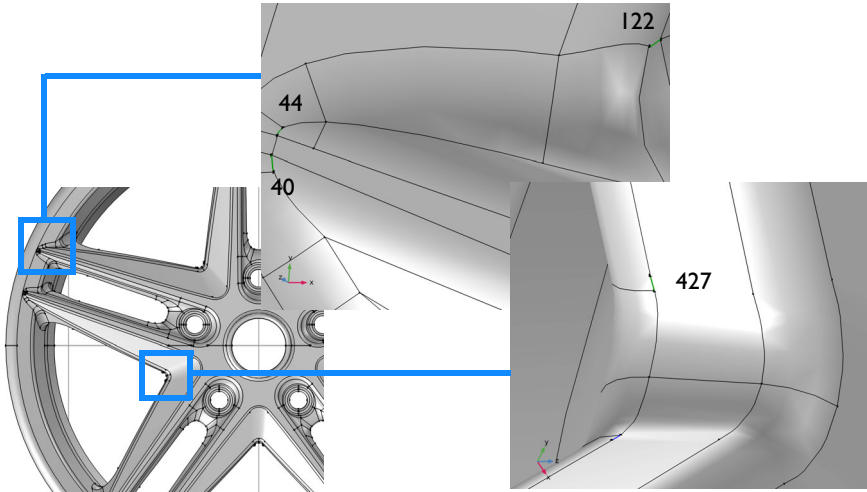

- 2 Click the Information I node, then use the Selection list and the Zoom to Selection  button next to the list to find edges 40, 44, 122, and 427.



Three of these edges are located close to where the spokes connect to the rim, and one is found close to the center of the wheel. Similar edges occur on each spoke.

- 3 To find an appropriate repair tolerance measure the length of the edges using the Measure toolbar button. The Messages window reports the following

EDGE	LENGTH
40	8.33e-4
44	4.77e-4
122	8.57e-4
427	8.91e-4

- 4 In the Geometry toolbar, click Defeaturing and Repair  and choose Repair .
- 5 Select the wheel rim for the Input objects list.
- 6 Enter 9e-4 in the Absolute repair tolerance text field.
- 7 Click the Build All Objects  button.

According to the Settings window for Repair 40 short edges were removed this time.

When defeaturing imported objects using Repair, you may experience better success if you add two Repair operations with the second one having a larger

tolerance, just as in this tutorial. Using a larger tolerance from the beginning may not always succeed to remove all small details due to geometric conditions, for example when several small details are adjacent to each other.

- 8 Next, click the Information 1 node below the Free Triangular 1 node, without rebuilding the mesh, and find that no edges remain in the list.

The associativity algorithm in the program ensures that deleted edges are automatically removed from the list in the Information node.

As a result of deleting the edges, the adjacent faces have been modified by the repair algorithm. Most likely this also results in a change of surface curvature in the vicinity of the deleted edges. The longer the deleted edge, the larger the difference from the original geometry that we can expect. For this reason it is

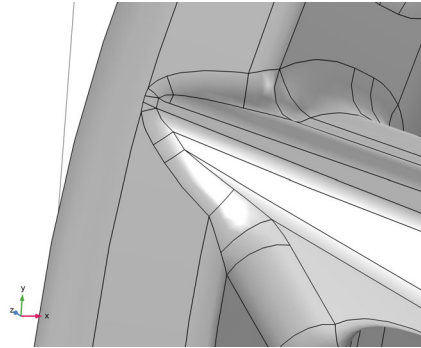

recommended to use a small tolerance together with the repair operation. If preserving the surface curvature is important for the analysis, virtual geometry operations, which work by hiding geometry features from the mesher, are available as an alternative. How you can do this is described further ahead, in the tutorial *Removing Small Geometric Entities Using Remove Details*.



Generating a Tetrahedral Mesh

Now that the defeaturing is completed, create a volume mesh for the wheel rim. The fastest way to do this is to reset the meshing sequence.

- 1 In the Mesh toolbar, click Reset , and click Yes in the Confirm Operation dialog box that appears.

The meshing sequence is reset to contain only a Size and a Free Tetrahedral node.

- 2 Click Build Mesh  .

- 3 To restore the view of the mesh, in the Graphics toolbar, click the Go to Default View  button, then click the Mesh Rendering  button.

The mesh contains approximately 70,000 tetrahedral elements, and as you can see if you examine it more closely the dense mesh regions you could see with the first triangular mesh are no longer present.

The information that appears corresponds to the second Information node with the previous triangular mesh.

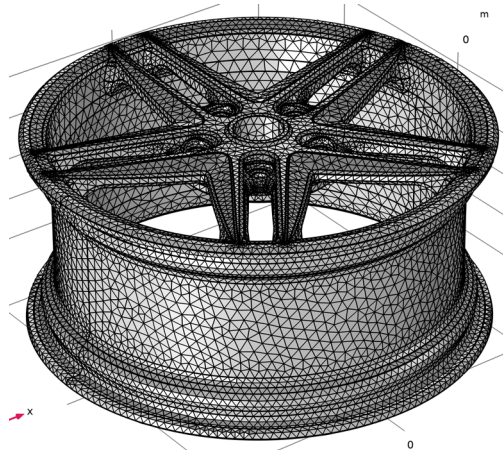

- 4 Click the Information node in the meshing sequence, then rotate the geometry in the Graphics window to find boundary 225 that appears in the selection.

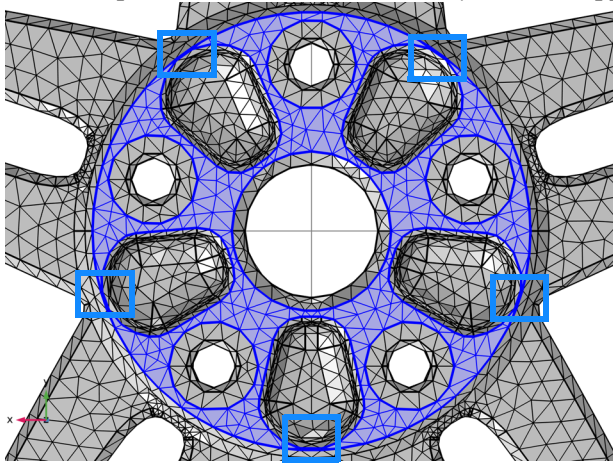

The highlighted face has several narrow regions (indicated by blue rectangles in the figure above), which cannot be resolved well enough using the current mesh size settings. These narrow regions are not associated with any small geometric entities, but are rather a consequence of the dimensioning of the geometry.

Therefore it is not possible to remove these using the Repair operation. One way you can remove the narrow region in this example is to delete the adjacent fillets from the geometry. This is described further ahead, in the tutorial *Removing Small Geometric Entities with the Defeaturing Tools*. You will find yet another method, by which you can automatically search for and remove

narrow regions, in the tutorial *Removing Small Geometric Entities with Remove Details*.

You may also choose to adjust the mesh size setting to better resolve small details in the geometry. Here you can do this by allowing smaller mesh elements on boundary 225.

- 5 Right-click the Free Tetrahedral 1 node and choose Size.
This adds a local Size node under Free Tetrahedral 1.
- 6 Choose Boundary from the Geometric entity level list in the Settings window for Size.
- 7 Select Boundary 225.
- 8 Click to expand the Element Size Parameters section and click the Custom button.
- 9 Select the Minimum element size check box and enter 2[mm] in the associated text field.
- 10 Click Build All.

The mesh that now builds without any Information nodes contains an additional 500 tetrahedral elements.

Removing Small Geometric Entities with the Defeaturing Tools

As an alternative to the repair operation described in the previous tutorial you can also apply defeaturing tools to remove small details from the geometry. Using these tools you can first search the geometry for features that fall within a set tolerance, then, after examining the search results, you can decide which ones to delete. While the repair operation has the advantage that it quickly removes every feature it can within a specified tolerance, the defeaturing tools gives you more control with selective removal of features.

To search for and remove small features from a geometry using the defeaturing tools, follow this general workflow:

- Import the file
- Search for and delete small features, such as
 - small faces
 - sliver faces
 - short edges
 - fillets

For the initial search for a feature it is good practice to use a tolerance slightly higher than the default import tolerance, 10^{-5} m. Thus, in a first attempt, search for small faces with a maximum size of 10^{-4} m. Continue by deleting all or some of the returned small faces, then search again with an even higher tolerance, for example $5 \cdot 10^{-4}$ m.

Meshing the geometry can also serve as a diagnostic tool for locating small features, and can be used in combination with the defeaturing tools. After meshing, you can measure some of the small edges and faces reported by the mesher to find a good starting point for a tolerance setting for the defeaturing tools.

The step-by-step instructions below guide you through how to defeature the geometry of the wheel rim that appeared in the previous example.

Model Wizard

- 1 Start COMSOL Multiphysics.
- 2 Select Blank Model to skip the steps of selecting physics interfaces and study type.



- 3 On the Home toolbar, click Add Component  and select 3D.

Importing the Geometry

Before importing the CAD file, make sure that the CAD kernel is used.

- 1 In the Model Builder window, under Component 1 (comp1) click Geometry 1.
- 2 In the Settings window for Geometry, from the Geometry representation list, choose CAD kernel.
- 3 On the Home toolbar click Import .
- 4 In the Settings window for Import click the Browse button.
- 5 In your COMSOL installation directory navigate to the folder `applications/LiveLink_for_Revit/Tutorials,_CAD_Import` and double-click the file `wheel_rim.x_b`.
- 6 Click Import.

Finding and Deleting Small Faces

- 1 In the Geometry toolbar, click Defeaturing and Repair  and choose Delete Small Faces .
- In the Tools window for Delete Small Faces, the wheel rim, **imp1**, already appears in the Input objects list.
- 2 In the Maximum face size text field enter $1e-4$.
Since the default import tolerance is 10^{-5} m it is good practice to start the search with 10^{-4} m, unless the imported CAD design is of a much larger scale.
- 3 Click the Find Small Faces button.
- Ten faces are listed in the Small face selection list.
- 4 Use the Zoom to Selection  button next to the list to find the faces on the rim, which are found around the bolt holes, as illustrated in the figure below.

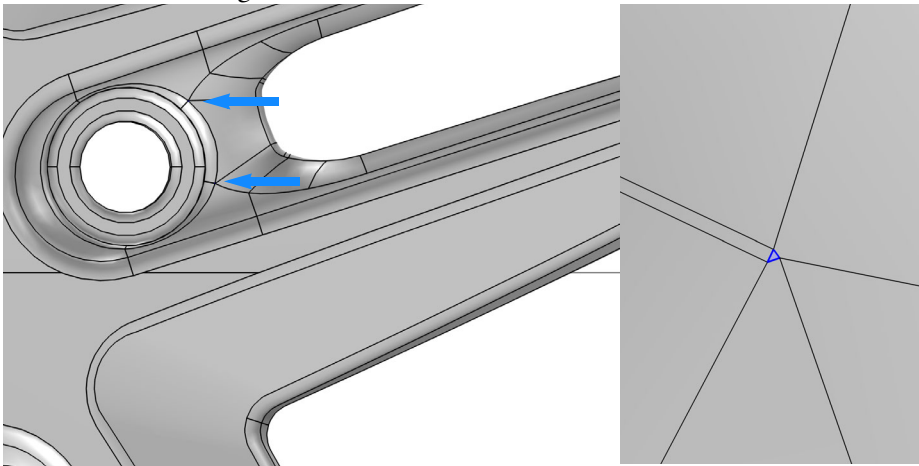
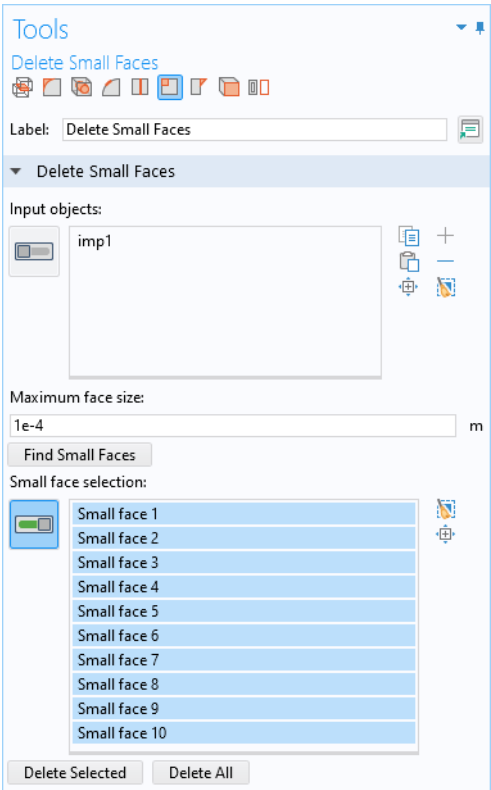

5 To delete all faces in the list click the Delete All button.

The tool removes small faces by collapsing them into a vertex (point). Therefore it is not recommended to delete larger faces this way as it might result in unexpected changes to the geometry.

Note that as the operation is done, the Delete Small Faces 1 (dsf1)  node is added to the geometry sequence in the Model Builder tree. The node allows you to go back and edit the delete operation.

The Tools window for Delete Small Faces continues to be displayed so that you can continue defeaturing using this or any of the other defeaturing tools.

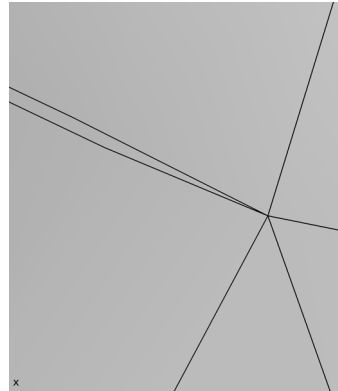

Finding and Removing Sliver Faces

Slivers are faces with a high aspect ratio, just like the ones next to those small faces you have just deleted.

- 1 From the toolbar on the top of the Tools window, click the Delete Sliver Faces button.
- 2 Enter $4e-4$ for the Maximum face width, then click Find Sliver Faces.

A total of 20 faces are found. In addition to the ten slivers around the bolt holes, there are ten more on the spokes. Use the Zoom to Selection button to find their location on the rim.

- 3 Click the Delete All button.

The tool removes sliver faces by collapsing them into an edge, and in this process it uses the tolerance specified for the search. For best results the tolerance needs to be close to the actual width of the face that is deleted. If it happens that a sliver cannot be deleted you can edit the settings for the operation to set a tolerance that is just slightly larger than the width of the face.

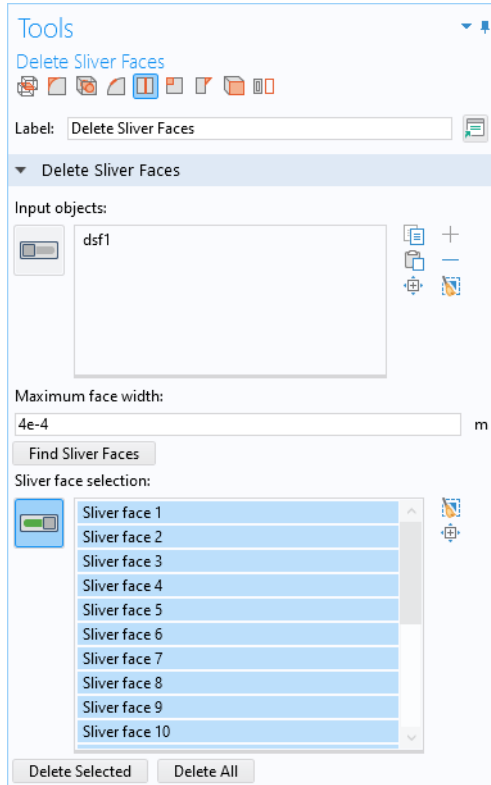

Finding and Removing Short Edges

- 1 From the toolbar on the top of the Tools window, click Delete Short Edges .
- 2 If not already selected, add the wheel rim to the Input objects list.
- 3 In the Maximum edge length text field enter $4e-4$.
- 4 Click the Find Short Edges button.
It seems that the previous operations have removed all edges that were shorter than this value.
- 5 Increase the Maximum edge length to $9e-4$, then click the Find Short Edges button again.
- 6 Take some time to find the edges in the list on the geometry and measure their length. They reoccur in similar places on each spoke. Some of the locations are indicated in the figure to the right.

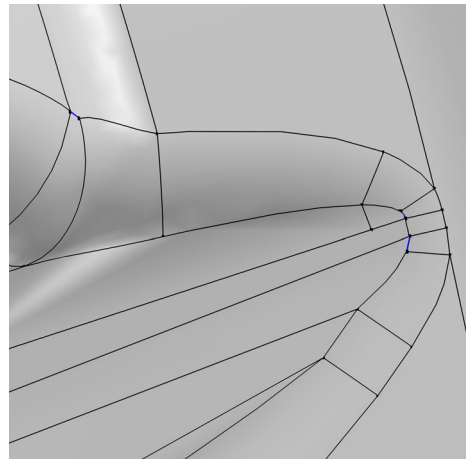
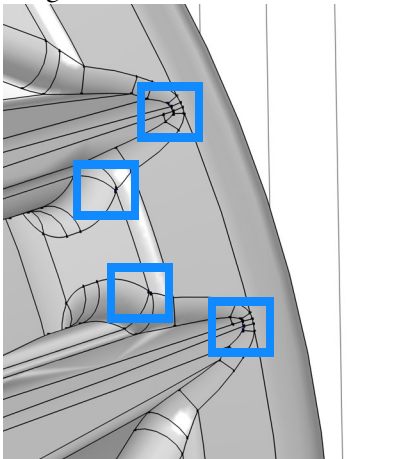
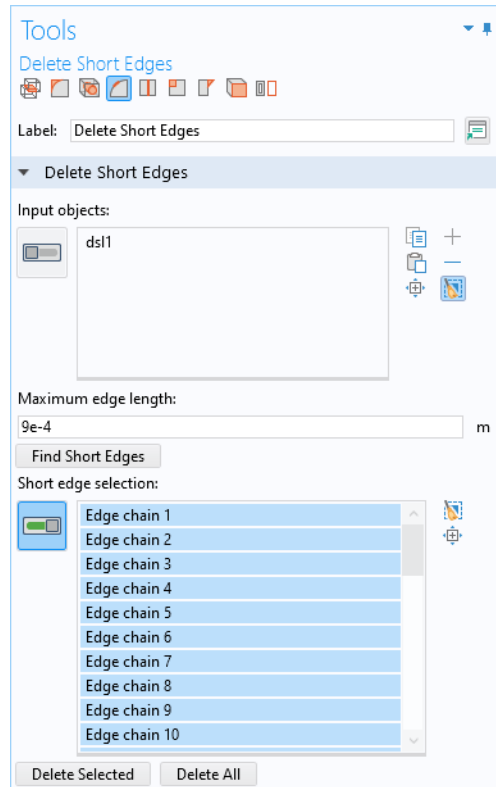

7 Click the Delete All button.

In the resulting geometry all short edges have been collapsed to vertices. The wheel rim geometry is now similar to the one after the last repair operation in the tutorial *Removing Small Geometric Entities with Repair*. The difference is that by using the defeating tools you can have more control over which entities to delete and in which order.

Just as for the Repair operation, it is recommended to use these tools with small tolerances to avoid large modifications to the geometry.

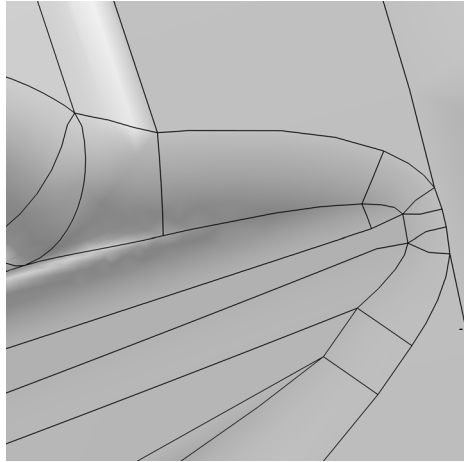

Finding and Deleting Fillets

In the previous tutorial, *Removing Small Geometric Entities with Repair*, we left the wheel rim geometry with narrow face regions remaining on a face. Here you will delete fillets adjacent to the narrow face regions to thereby make the face wider.

- 1 From the toolbar on the top of the Tools window, click the Delete Fillets  button.
 - 2 If not already selected, add the wheel rim to the Input objects list.
 - 3 In the Maximum fillet radius text field enter 2 [mm].
 - 4 Click the Find Fillets button.
- Twenty fillets with a radius smaller than 2 mm are found. Remove only the fillets around the cavities on the back of the wheel rim. These are highlighted in the figure further below.
- 5 First, click Clear Selection next to the Fillet Selection list.

- 6 Select Fillet 16 to 20 from the list, or, in the Graphics window, select a face each from the fillets highlighted in the image to the right.
- 7 Click the Delete Selected button.

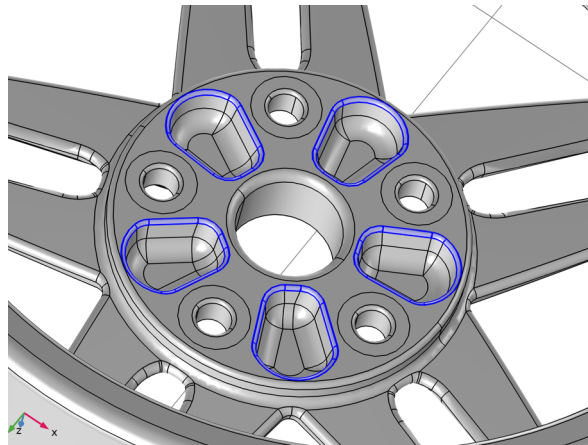
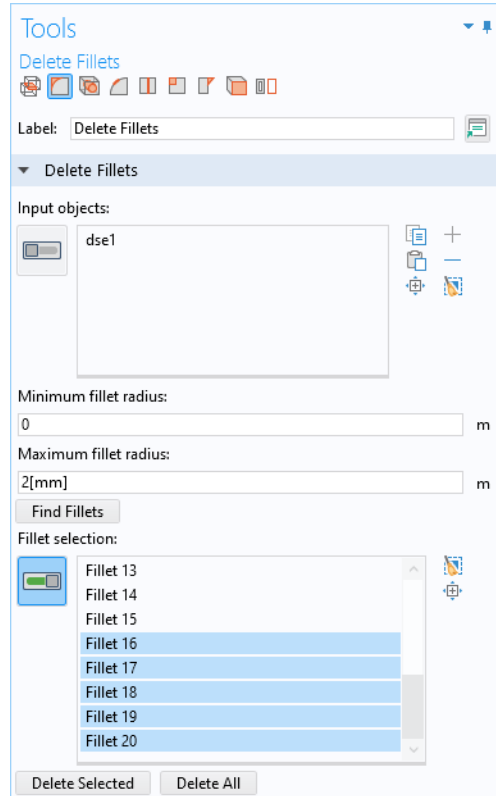

Generating a Tetrahedral Mesh

As a final step generate the default tetrahedral mesh for the wheel rim.

In the Home toolbar, click  Build Mesh.

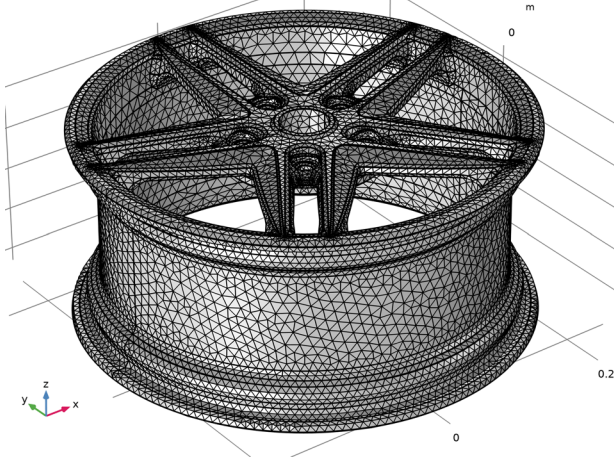

The generated mesh consists of approximately 68,000 elements and there should be no Information nodes appearing under the Mesh 1 node due to small geometric entities.

The next tutorial describes how to automatically defeature the same geometry using virtual geometry operations.

Removing Small Geometric Entities with Remove Details

This tutorial demonstrates the use of the Remove Details operation for automatic defeaturing of the very same wheel rim geometry as in the previous two tutorials. Remove Details leverages virtual geometry operations to automatically detect and delete small features on the finalized geometry.

The repair and defeaturing tools that find and delete small geometry features can operate only within the limits of what is allowed by the topology of the geometry. To handle more complex cases, where defeaturing fails, you can use virtual geometry operations. With these tools you can set geometric entities, such as vertices, edges, or faces, to be ignored by the mesher. Since selected elements are “hidden” from the mesher, meshing takes place on a virtual geometry, hence the name virtual operations.

Virtual operations work on the finalized geometry, that is, the geometry after the Form Union or Form Assembly nodes. This means that using these operations you may remove small domains that result from intersecting solid objects. Another benefit is that they keep the curvature of the geometry, which may be important when removing larger faces, or for certain physics applications where altering the curvature of the geometry can, for example, give rise to stress concentrations.

Model Wizard

- 1 Start COMSOL Multiphysics.
- 2 Select Blank Model to skip the steps of selecting physics interfaces and study type.
- 3 On the Home toolbar, click Add Component  and select 3D.

Importing the Geometry



Before importing the CAD file, make sure that the CAD kernel is used.

- 1 In the Model Builder window, under Component 1 (comp1) click Geometry 1.
- 2 In the Settings window for Geometry, from the Geometry representation list, choose CAD kernel.
- 3 On the Home toolbar, click Import .
- 4 In the Settings window for Import, click Browse.

- 5 In your COMSOL installation directory navigate to the folder `applications/LiveLink_for_Revit/Tutorials,_CAD_Import` and double click the file `wheel_rim.x_b`.
- 6 Click Import.

Using Remove Details

If you already know that your imported CAD geometry needs defeaturing, an effective workflow is to add the Remove Details feature to the geometry sequence, then build a mesh. Meshing may reveal that further defeaturing is needed, in which case you can go back and adjust the tolerance for Remove Details, or add additional Remove Details, or other virtual geometry operations. Test this workflow on the imported wheel rim geometry.

- 1 In the Geometry toolbar click Remove Details .
- 2 Click the Build Selected  button in the Settings window for Remove Details.

The Remove Details operation analyzes the geometry to find and remove details such as vertices with continuous tangent, short edges, small and sliver faces, narrow face regions, and thin domains. These details are removed by setting up a sequence of virtual geometry operations.

According to the Information section in the Settings window for Remove Details, several vertices and edges were ignored, and edges, faces, and face regions were collapsed.

The automatically determined size for the details that are removed is calculated as 0.001 times the longest edge of the bounding box for the input entities. Depending on the input this tolerance could be too small, so that further defeaturing may

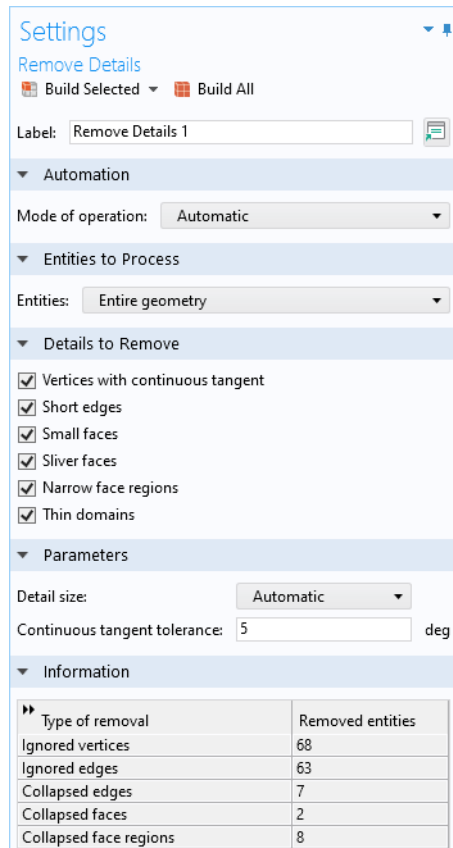

Settings
Remove Details

Build Selected Build All

Label: Remove Details 1

Automation
Mode of operation: Automatic

Entities to Process
Entities: Entire geometry

Details to Remove

- Vertices with continuous tangent
- Short edges
- Small faces
- Sliver faces
- Narrow face regions
- Thin domains

Parameters
Detail size: Automatic
Continuous tangent tolerance: 5 deg

Information

Type of removal	Removed entities
Ignored vertices	68
Ignored edges	63
Collapsed edges	7
Collapsed faces	2
Collapsed face regions	8

be needed. The fastest way to determine if this is the case is to build the mesh and check if the mesh generator displays any Information about small entities.

- 3 In the Home toolbar, click Build Mesh  .

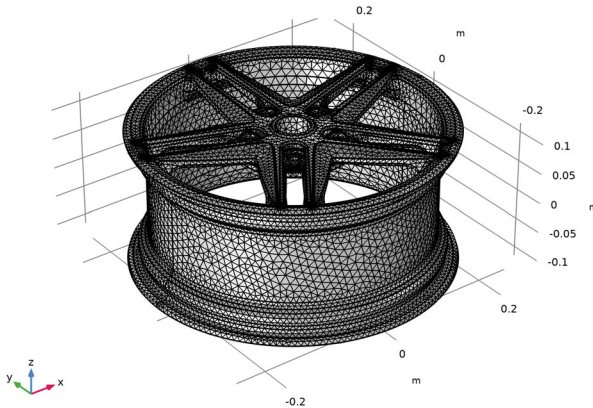

- 4 Expand the Mesh 1 node in the Model Builder.

Two Information nodes are displayed under Mesh 1.

- 5 In the Selection list inside the Settings window for Information 1, click edge 39.

- 6 In the Mesh toolbar, click Measure  .

The Messages window displays the length of the edge, which is 8.3282×10^{-4} m — that is, $8.3282 \cdot 10^{-4}$ m or about 0.033 inches. All edges in the list have the same length, and all are found on the spokes of the wheel. Now that you know the length of these remaining short edges, you can go back and modify the tolerance for Remove Details so that these edges can also be deleted. But first, examine the second Information node.

7 Select Information 2 under the Mesh 1 node.

The face appearing in this Information node has several narrow regions (indicated by blue rectangles in the figure below), which cannot be resolved well enough using the current mesh size settings.

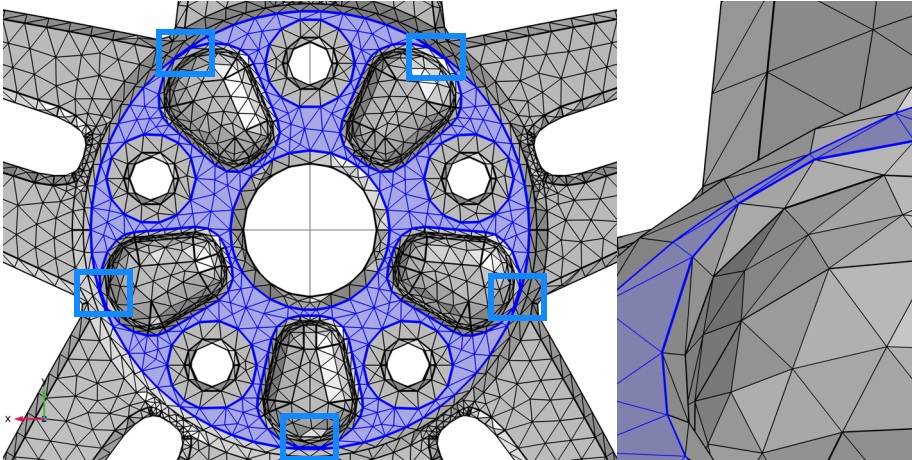

Since it is not easy to measure the width of a narrow face region without modifying the geometry, the fastest way to remove the narrow region is to manually increase the tolerance for Remove Details until the narrow regions are removed.

8 Click the Remove Details 1 node in the Model Builder.

9 In the Parameters section, choose Absolute from the Detail size list.

The currently displayed value, about $5e-4$, is the automatically determined tolerance that was used the last time Remove Details ran.

10 Increase the Maximum absolute size to $8.5e-4$.

11 Click the Build Selected  button.

The table in the Information section in the Settings window for Remove Details should now look like in the screenshot to the right.

Information	
Type of removal	Removed entities
Ignored vertices	68
Ignored edges	68
Collapsed faces	20
Collapsed face regions	5

12 In the Mesh toolbar, click Build Mesh .

No Information nodes remain. In the following, take a closer look at how Remove Details deletes the small entities from the geometry.

Manual Mode for Remove Details



- 1 In the Remove Details settings window, locate the Mode of operation list and set it to Manual.

The Remove Details node in the Model Builder expands to reveal the automatically generated sequence of virtual geometry operations.

In manual mode you can examine and edit each individual operation. You could, for example, exclude entities that you do not want to remove from the geometry. You could also add further virtual operations to the automatically generated sequence to remove additional entities.

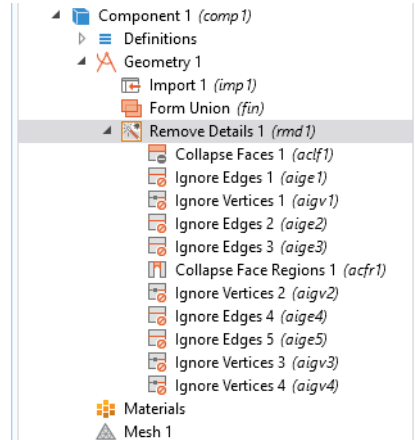
Details are removed in different passes using increasing tolerances to remove larger and larger details. A simple geometry may only need one pass, but with a more complex geometry, like this wheel rim, the Remove Details operation goes through three passes and a cleanup pass at the end. Take a closer look at some of the virtual operations in the sequence.



- 2 In the Model Builder window, under Component 1 (comp1)>Geometry 1>Remove Details 1 (rmd1) click Collapse Faces 1 (acfl1) .
- 3 In the Settings window for Collapse Faces, under Faces to collapse, toggle the  Activate Selection toggle button.

4 Use the Zoom to Selection  button to find some of the faces on the rim.

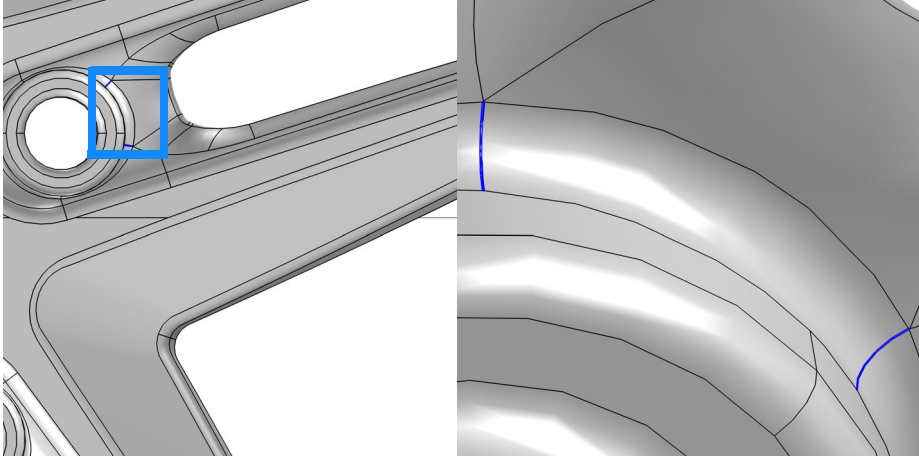

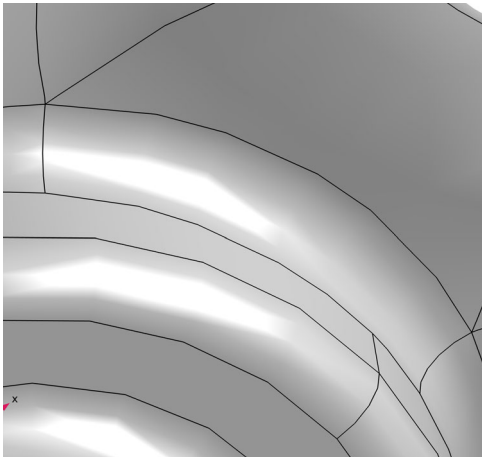

Both small faces and sliver faces are removed in this operation. Small faces with sides that are similar in length are usually collapsed into a vertex, whereas sliver faces that have a high aspect ratio are more often collapsed into one of the longer edges. As an alternative to the Collapse Faces operation you can also use the *Merge Edges* operation that gives more control over which edges are kept when collapsing faces.

5 Click the Build Selected  button.



6 In the Model Builder window, click Ignore Edges 1 (aige1) .

- 7 In the Settings window for Ignore Edges toggle the  Activate Selection toggle button, then find some of the edges on the geometry by using Zoom to Selection . All edges in the list are next to sliver faces, similarly to the image displayed to the right. The sliver faces are wider compared to those that were collapsed in the previous operation. The faces on the two sides of the edge are continuous across the edge, and it is thereby suitable to form a larger composite face by ignoring the edge.

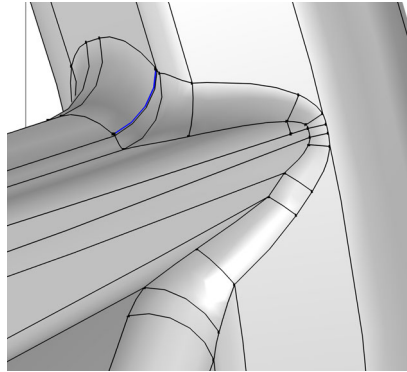

As an alternative to the Ignore Edges operation you can also use the *Form Composite Faces* operation.

- 8 Click the Build Selected  button. The geometry in the Graphics window is updated with the newly formed composite faces.

The vertex adjacent to the removed edge can also be removed to avoid leaving a short edge in the geometry. This is done by the next operation in the sequence.

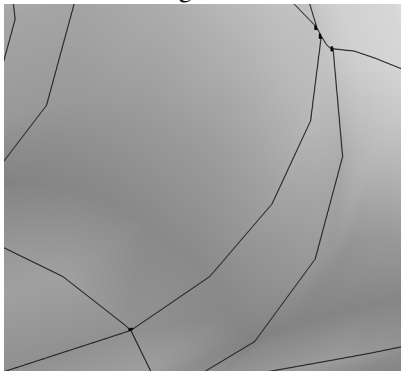
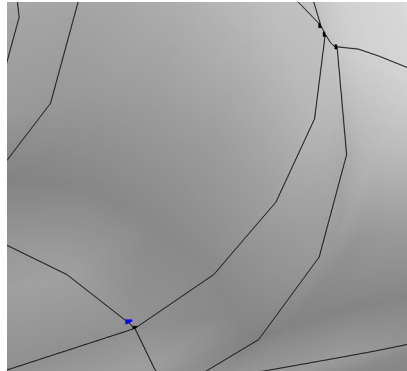

- 9 In the Model Builder window, click Ignore Vertices 1 (aigv1) .

- 10 Click Build Selected  in the Settings window for Ignore Vertices.





The sequence of virtual operations generated by Remove Details includes several other Ignore Edges and Ignore Vertices operations to remove slivers

with increasing face width. In the following take a closer look at the *Collapse Face Regions* operation, that is added to the sequence to detect and remove narrow face regions.

- 11 In the Model Builder window, click Collapse Face Regions 1 (acfr1) .
- 12 In the Settings window toggle the  Activate Selection toggle button.

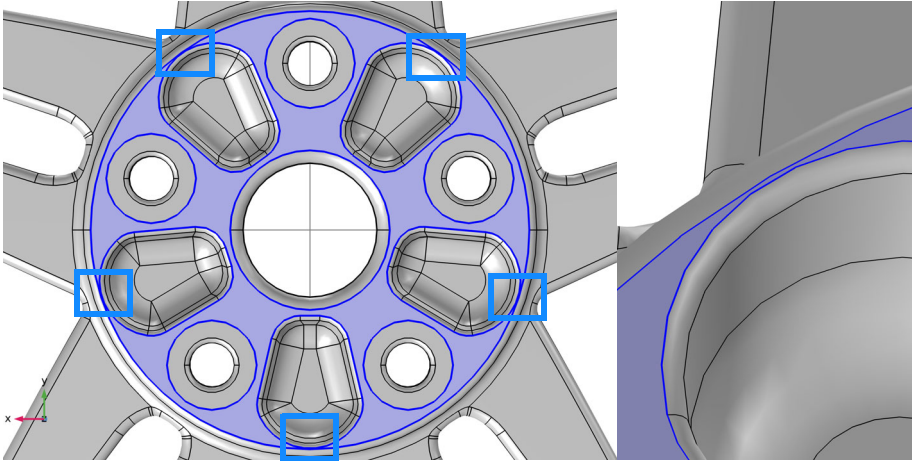
The face with the narrow regions is on the back of the rim, it is the very same face that appeared in the mesh warning in the first part of this tutorial.



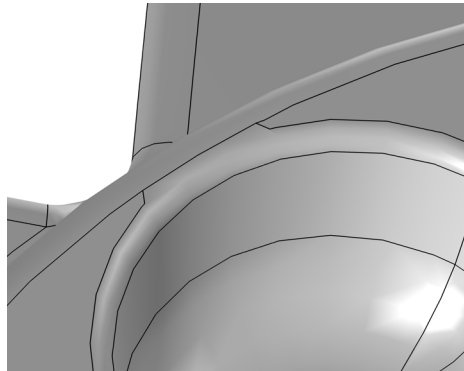

- 13 Click Build Selected  in the Settings window for Collapse Face Regions.

The operation removes a detected narrow region by first partitioning the edges adjacent to it by creating vertices. Then, new edges are created between the vertices to partition the face. This creates a sliver face in place of the narrow region. As the last step, the created sliver face is collapsed into an edge.



Finally, switch Remove Details to automatic mode, and mesh the geometry.

- 14 In the Model Builder window, click Remove Details 1 (rmd1) .
- 15 In the Settings window for Remove Details, locate the Mode of operation list and set it to Automatic.
- 16 In the Mesh toolbar, click  Build Mesh.

Creating a Fluid Domain Inside a Solid Structure

The majority of 3D CAD files include only the geometry of the product to be manufactured. For finite element analysis, however, you find yourself often in a situation where additional geometry is needed, for example, to analyze the flow inside or outside a device. The example in this section, involving the geometry for an exhaust manifold, demonstrates how to create an extra domain for flow analysis after importing and defeaturing a CAD assembly. The following steps are covered:

- Importing a Parasolid® file
- Deleting a larger detail from the geometry
- Creating the union of all imported objects needed to generate a domain inside the objects
- Moving the imported objects to eliminate a gap
- Using the cap faces operation to create the additional domain
- Controlling where an operation is inserted in the geometry sequence
- Finding and removing fillets and holes from the geometry

Model Wizard

- 1 Start COMSOL Multiphysics.
- 2 Select Blank Model to skip the steps of selecting physics interfaces and study type.
- 3 On the Home toolbar, click Add Component  and select 3D.

Importing the Geometry

Before importing the CAD file, make sure that the CAD kernel is used.

- 1 In the Model Builder window, under Component 1 (comp1) click Geometry 1.
- 2 In the Settings window for Geometry, from the Geometry representation list, choose CAD kernel.
- 3 On the Home toolbar, click Import .
- 4 In the Settings window for Import click the Browse button.

5 In your COMSOL installation directory navigate to the folder `applications/LiveLink_for_Revit/Tutorials,_CAD_Import` and double click the file `exhaust_manifold.x_b`.

6 Click Import.

As soon as the import is done the geometry appears in the Graphics window.

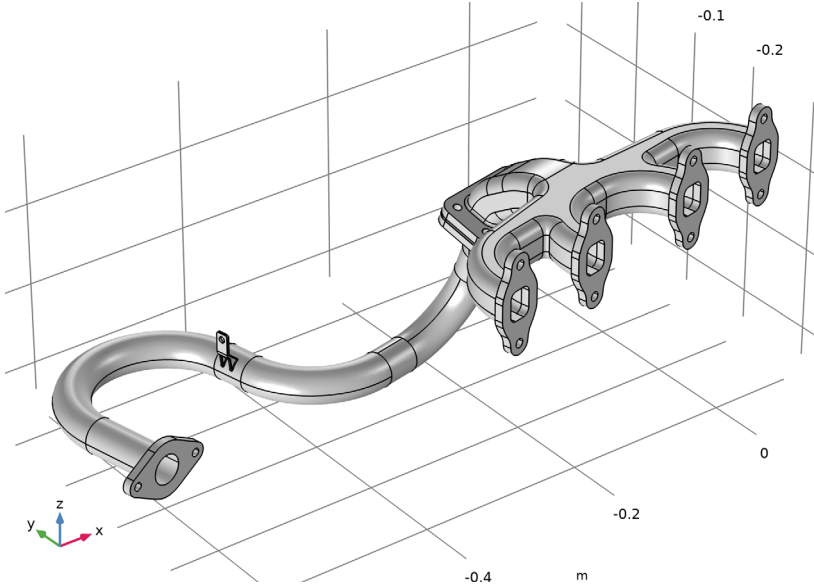

The geometry consists of three solid objects and is hollow inside.

Opening the Selection List Window

When working with imported CAD assemblies it is helpful to view a list of the imported objects. You can do this in the Selection List window.

- 1 In the Home toolbar, click  Windows and choose Selection List.
- 2 In the Selection List window that appears, click through the listed objects to identify each component.

The name of an imported object is derived from the tag of the import feature and the name of the object from the imported CAD file, or a number when the file does not contain any names. The list also indicates the object type, which can be solid (objects with an interior volume), surface, or mixed. The lower

section of the window that lists named selections is empty as there are no named selections in the model.

The three imported solid objects are the downpipe (`imp1(1)`), the gasket (`imp1(2)`), and the manifold (`imp1(3)`).

Deleting Details

Defeaturing an imported CAD geometry may involve deleting geometric details that may not be important for a simulation. In the following use the Replace Faces operation to remove the mounting bracket from the downpipe.

- 1 Click the  Zoom Box button in the Graphics toolbar and zoom in to the mounting bracket.

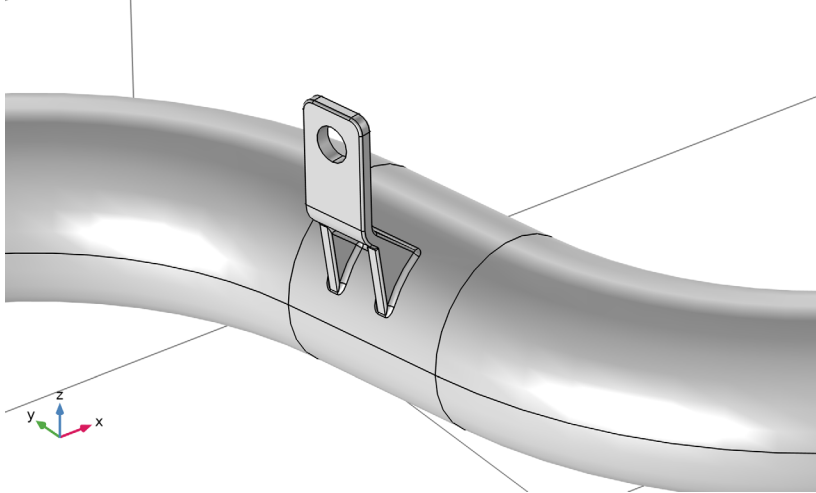

- 2 In the Geometry toolbar, click  Defeaturing and Repair and choose Delete Faces.

Using this tool you can delete larger geometric details, and the resulting gap is automatically healed by one of two methods: the surrounding faces are grown or shrunk to cover the gap; a new face is constructed based on the edges of the gap.

Add the boundaries of the bracket to the Faces to delete list in the Tools window for Delete Faces. The easiest to do this is as follows.

- 3 Click the  Select Box button in the Graphics toolbar.

- 4 Hold the left mouse button to draw a square around the bracket to select its faces. Make sure that the selection includes all faces that make up the bracket, including the fillet faces.

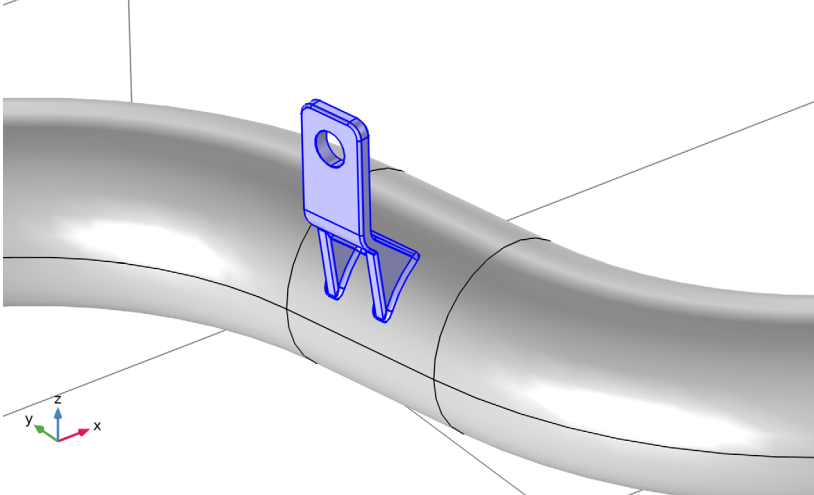

- 5 In the Tools window for Replace Faces, click Replace Selected.
The faces of the mounting detail are removed and the surrounding boundaries are extended to cover the gap.

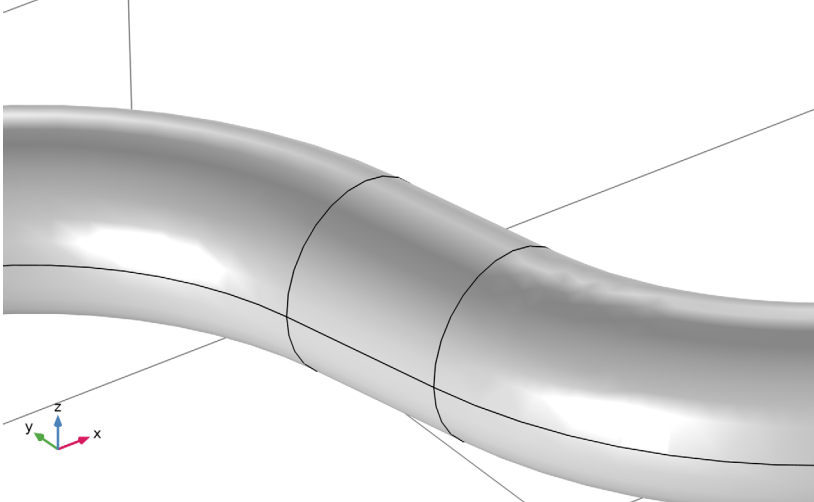

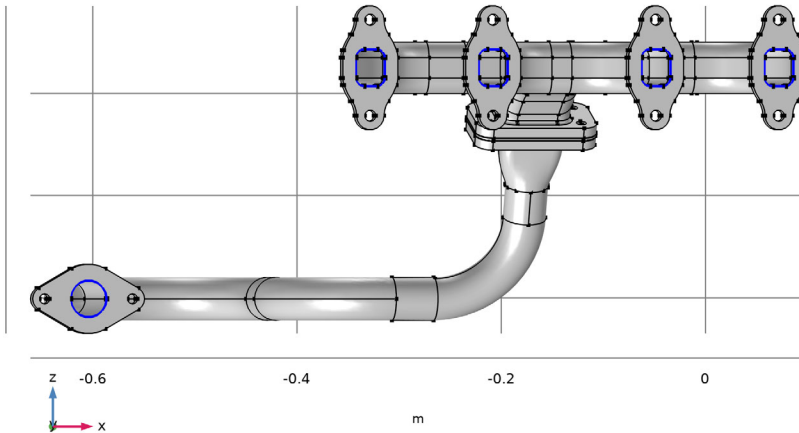

Creating an Explicit Selection

The Cap Faces operation, which you will use to create a domain inside the manifold, needs an input in form of the bounding edges of the empty volume that should be turned into a solid. For this exhaust manifold these are the edges highlighted in the figure below.





You could select these edges directly in the Cap Faces operation, however a more efficient way, which only requires the selection of one segment from each edge loop, is to use an Explicit Selection where you have the option to automatically include continuous edges in the selection.

- 1 In the Geometry toolbar click Selections  and choose Explicit Selection .
- 2 In the Settings window for Explicit Selection select Edge from the Geometric entity level list.
- 3 Also select the Group by continuous tangent check box.
- 4 From the Graphics window select one edge each from the edge loops highlighted in the figure above. Continuous edges are automatically added to the selection. When done check that all edges are highlighted, just as in the figure.
- 5 Switch to the Selection List window, or open it again, to check that Explicit Selection 1 now appears under Edge Selections.

Creating the Union of All Objects

The Cap Faces operation can only generate a solid domain inside the manifold if the created faces result in a new closed volume. To make sure that this is the case you will now create the union of all imported objects.

- 1 In the Geometry toolbar, click  Booleans and Partitions and choose Union.
- 2 Click the  Select All button in the Graphics toolbar.
- 3 In the Settings window for Union, click  Build Selected.
Examine this new geometry object using the Measure tool.
- 4 Right-click Geometry 1 and choose Measure.
- 5 Select the object uni1 in the Graphics window.

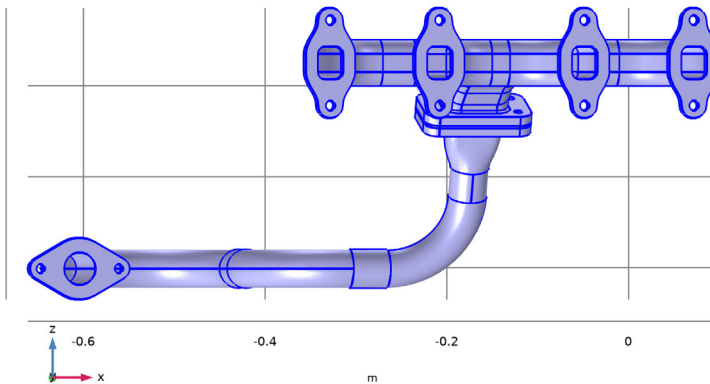

According to the information displayed in the Measure window the object uni1 contains 4 domains.

If the 3 objects do not overlap, the expected result after the union is an object with 3 domains. The presence of an additional domain after the Union operation indicates an overlap between the imported objects.

Detecting Interferences

The easiest way to check imported CAD assemblies for overlaps and gaps is to use the Detect Interferences tool. Since this tool works on individual objects, you can build the Import 1 feature first.

- 1 In the Model Builder window, right-click Import 1 (imp1) and choose Build Selected.
- 2 In the Geometry toolbar, click Defeaturing and Repair and choose  Detect Interferences.
- 3 In the Tools window, Click Find Interferences.
- 4 From the Interfering Faces list, select Intersection 1 and click Zoom Selected, then rotate and pan to get a better view of the region around the interfering objects, similar to the figure below.

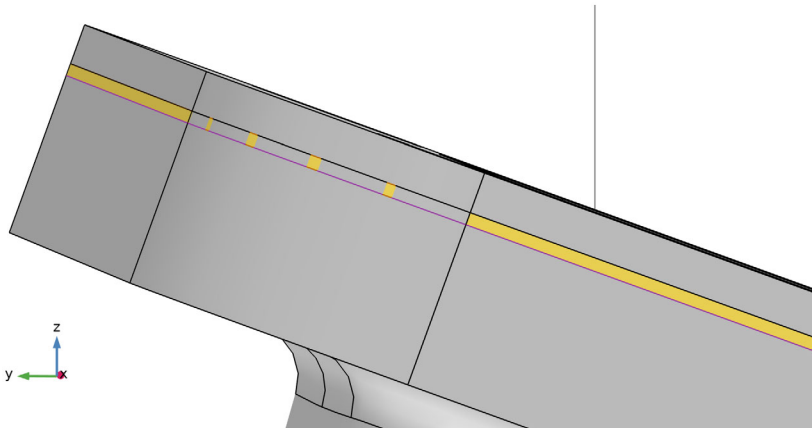
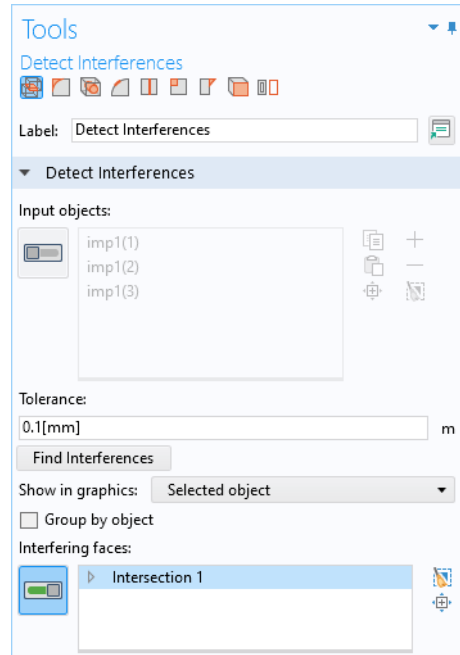

The objects not involved in the intersection are hidden by default, this makes it easier to visualize each intersection.

5 From the Show in graphics list, choose All objects.

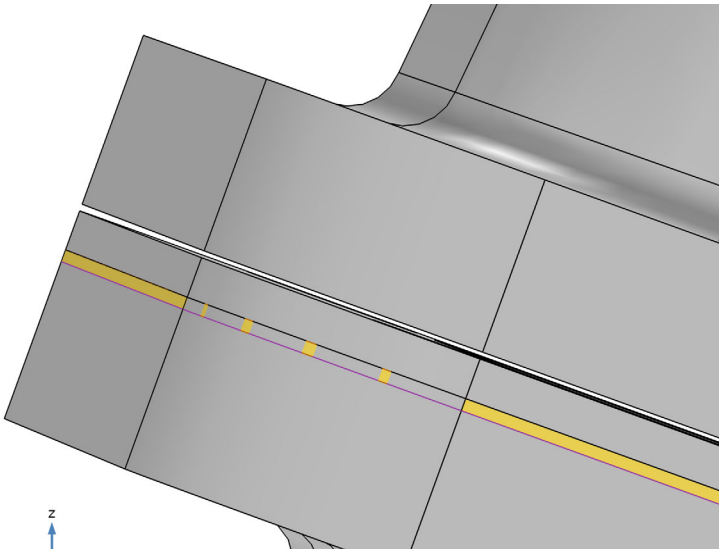

It seems that in addition to the overlap there is also a gap between the gasket and the manifold. This is also evident since the interference detection tool did not find any touching boundaries. Try to increase the tolerance for the Detect Interferences tool in order to detect and get a measurement of the gap.

6 In the Tools window for Detect Interferences, in the Tolerance text field, type 0.7 [mm].

7 Click Find Interferences.

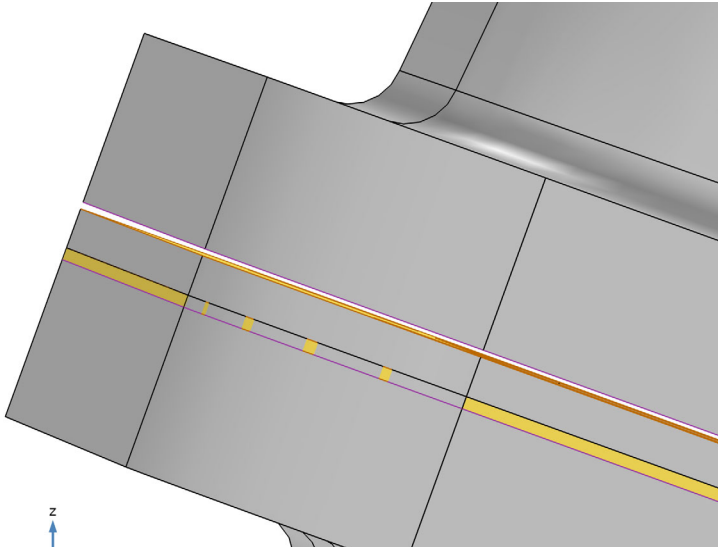



This time the gap is detected. The gap distance is displayed in the Interfering faces list, and it is 0.4 mm.

- 8 Examine the faces involved in the intersection and gap by expanding the entries in the Interfering faces list and clicking on the sub-nodes. Selected boundaries are highlighted in the Graphics window. Turn on Wireframe Rendering  from the Graphics window for a better view, click the same button again to turn it off.

Moving the Objects to Close the Gap

One way to close the gap is to move the gasket such that it will touch the manifold. Since the touching boundaries are planar faces, you can align the two objects using a Rigid Transform operation. Rigid Transform moves an object until its chosen source coordinate system matches a chosen target coordinate system. You will start with configuring two Work Planes that will define the source and target coordinate systems.

- 1 In the Model Builder window, click Import 1 (imp1).
- 2 Click the  Select Objects button in the Graphics toolbar.
- 3 Click the  Click and Hide button in the Graphics toolbar.
- 4 In the Graphics window select the object for the manifold (imp1 (3)) to hide it from view.

5 In the Geometry toolbar, click  Work Plane.

This first work plane will become the source Work Plane for the gasket.

6 In the Settings window for Work Plane, from the Plane type list, choose Face parallel.

7 In the Graphics window, on the object for the gasket (`imp1(2)`), select Boundary 4 (the boundary that will touch the manifold).

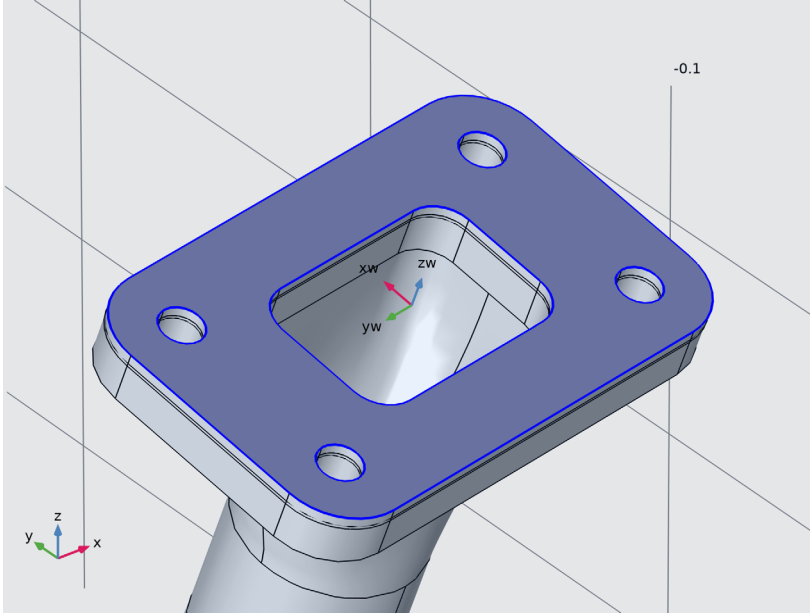

8 In the Label text field, type `gasket coordinate system` to recognize the plane later.

9 Click  Build Selected.

10 Click the  View Hidden Only button in the Graphics toolbar to display only the object for the manifold in the Graphics window.

11 To make the setup of the next work plane easier click the  Wireframe Rendering button in the Graphics toolbar.





12 In the Geometry toolbar, click  Work Plane. This will define the target coordinate system.

13 In the Settings window for Work Plane, from the Plane type list, choose Face parallel.

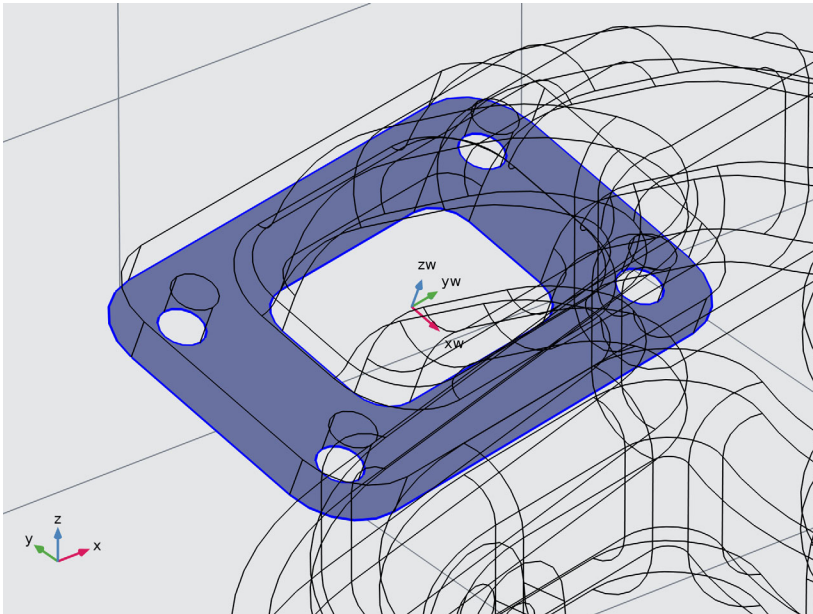
14 In the Graphics window, on the object for the manifold (`imp1(3)`), select Boundary 83, which is the boundary that will align with the gasket.

- 15 Select the Reverse normal direction check box. After this the arrow for the zw direction should point in the same direction as in the figure below. Since Rigid Transform moves the objects by aligning the coordinate systems, the z-axes of the two work planes must point in the same direction.



- 16 In the Label text field, type manifold coordinate system to recognize the plane later.
Reset the view settings.
- 17 Click the  Wireframe Rendering button in the Graphics toolbar.
- 18 Click the  View Unhidden button in the Graphics toolbar.
- 19 Click the  Reset Hiding button in the Graphics toolbar.
- 20 In the Geometry toolbar, click  Transforms and choose Rigid Transform.
- 21 In the Graphics window, select the object for the gasket (`imp1(2)`).
- 22 In the Settings window for Rigid Transform, locate the Coordinate System for Objects section.
- 23 From the Work plane for objects list, choose gasket coordinate system (`wp1`).
- 24 Locate the Coordinate System to Match section. From the Work plane list, choose manifold coordinate system (`wp2`).

25 Click  Build Selected.

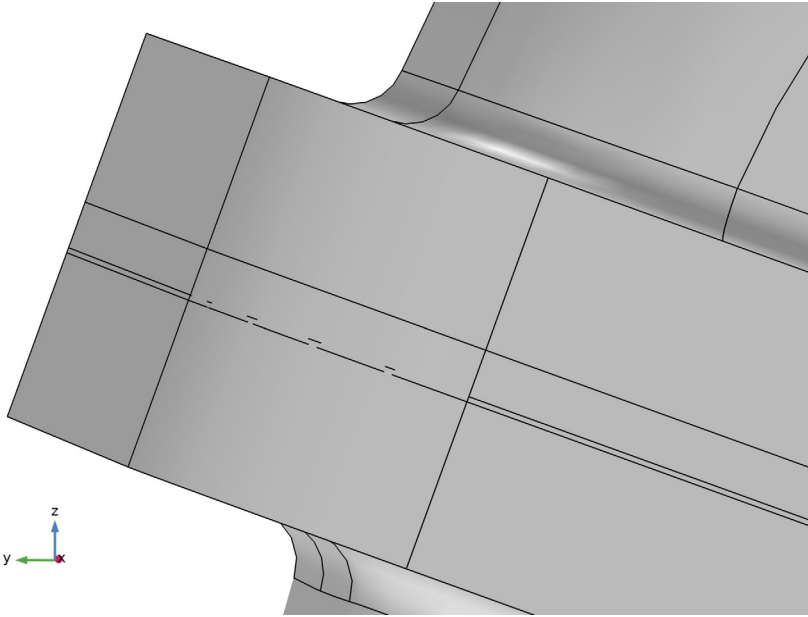

The gap between gasket and manifold is now eliminated, but there is still a slight overlap between the gasket and downpipe. Further ahead, you will delete the thin domain that results from the overlap by using *Remove Details*.

Creating a Domain with Cap Faces

At this time the geometry is ready for creating the inside domain. First you need to make sure that the Cap Faces operation will be inserted after the Union 1 node in the geometry sequence.

- 1 In the Model Builder window, right-click Union 1 (uni1) and choose Build Selected.

- 2 In the Geometry toolbar, click  Defeaturing and Repair and choose Cap Faces.

The bounding edges of the empty volume inside the manifold are included in Explicit Selection 1 (sel1).

- 3 In the Settings window for Cap Faces, from the Bounding Edges list choose Explicit Selection 1, which still includes the correct edges since geometry operations are associative.

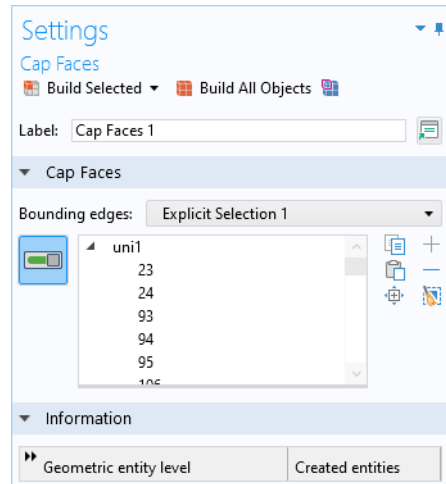

4 Click  Build Selected to complete the operation.

The operation closed off the inlets and outlets with new faces. The operation also created a solid domain where it used to be a void inside the exhaust manifold.

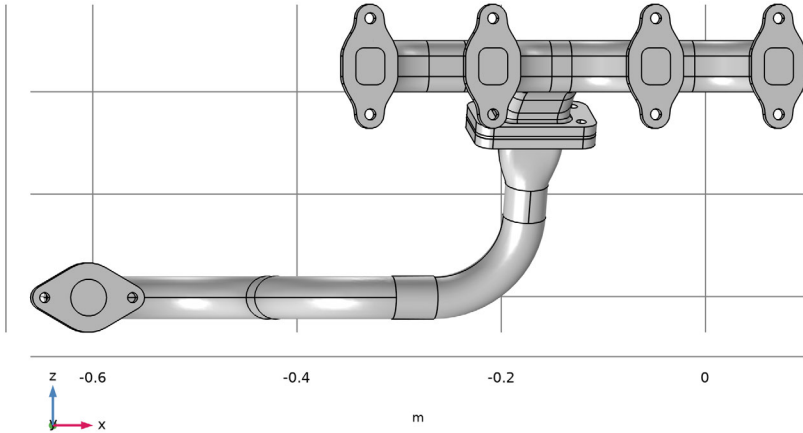

According to the Information section of the Settings window for Cap Faces, 5 boundaries and 1 domain were created.

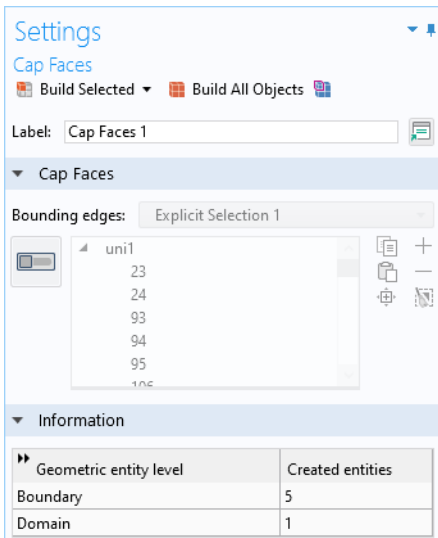



Removing Fillets from the Geometry



Assume that you are preparing the geometry for a heat transfer analysis for which you have decided to remove some fillets.

Note: A geometry object that contains more than one domain is a non-manifold object which does not support defeaturing operations such as deleting fillets.

In order to remove the fillets you need to insert the Delete Fillets operation before the Union 1 node in the geometry sequence.

- 1 Under the Geometry 1 node, right-click Union 1 (uni1)  and choose Build Preceding .

The Union 1 (uni1) node becomes unavailable, and the Explicit Selection 1 (sel1) node becomes the current node, which is indicated by a green rectangle around its icon. You can now apply the defeaturing operation, as it is inserted before the Union 1 (uni1) node.

- 2 In the Geometry toolbar, click  Defeaturing and Repair and choose  Delete Fillets.
- 3 In the Tools window all objects already appear in the Input objects list, and you can enter 0.003 in the Maximum fillet radius text field.
- 4 Click Find Fillets to search for fillets with a radius less than 0.003 m in the geometry.

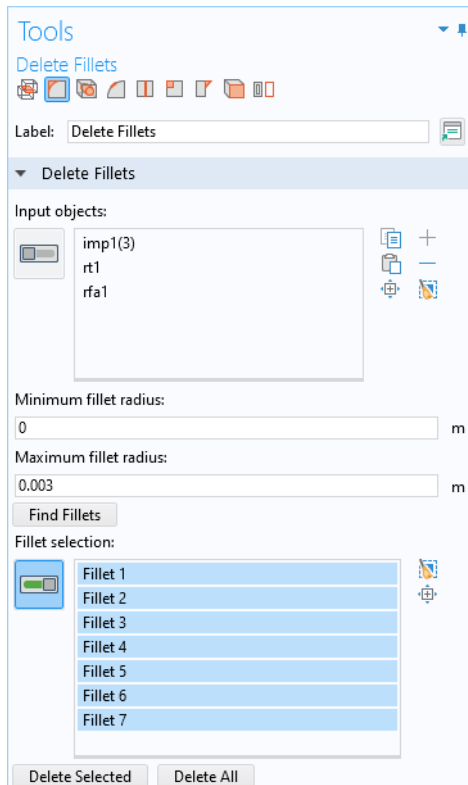

- 5 Seven fillets are found by the tool. These appear in the Fillet selection list, and they are also highlighted on the geometry.

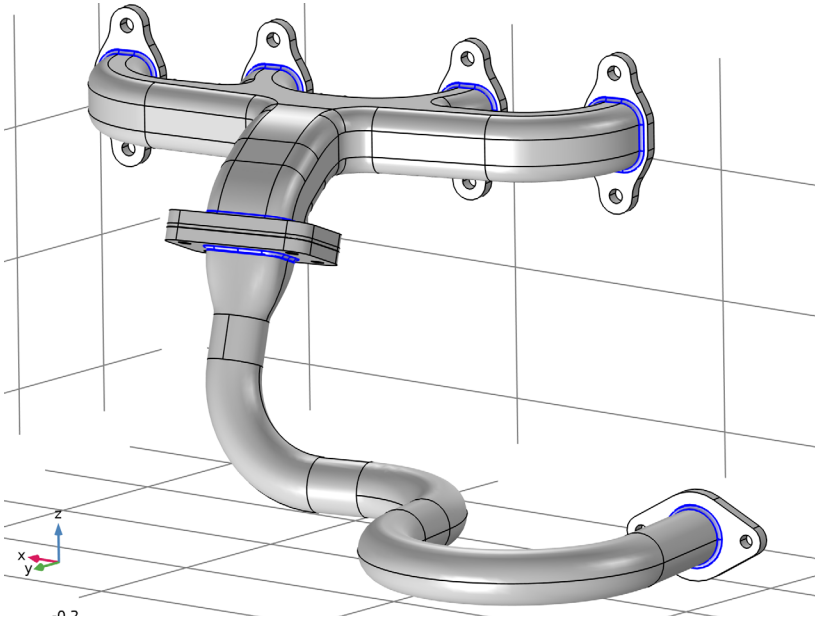

- 6 Clicking Delete All in the Tools window to remove all detected fillets.

As the operation completes and the fillets are removed note that the Delete Fillets 1 (dfi1) node is inserted into the geometry sequence, just above the Union 1 (uni1) node. The Union 1 (uni1) node is still unavailable, meaning that it is currently not built.

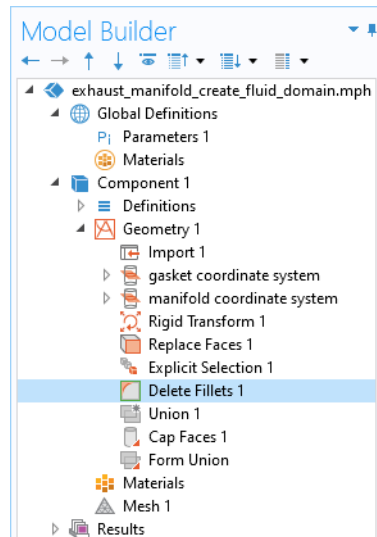

Deleting Holes from the Geometry

You can find and delete cylindrical holes in solid objects just as easily as deleting fillets.

- 1 In the Tools window for Delete Fillets, click  Delete Holes.
- 2 In the Maximum hole radius text field, type 10[mm].
- 3 Click Find Holes.

The tool found 22 holes, which appear in the Hole selection list, and they are also highlighted on the geometry.

- 4 Click Delete All to remove all holes.

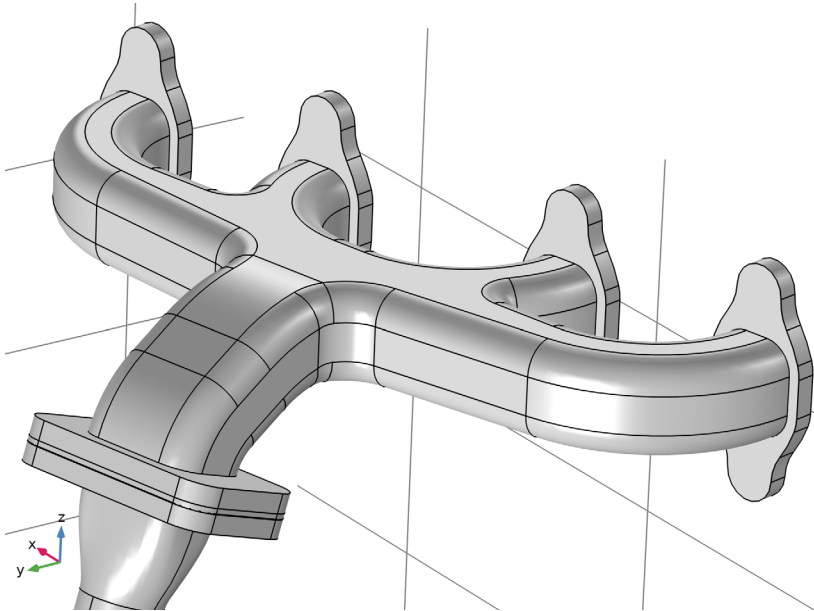

The holes are now deleted, and, similarly to the previous defeaturing operation, a Delete Holes 1 (dho1) node is inserted into the geometry sequence just above the Union 1 (uni1) node.

Removing a Thin Domain Using Remove Details

- 1 In the Geometry toolbar, click  Remove Details.

2 In the Settings window for Remove Details, click  Build Selected.

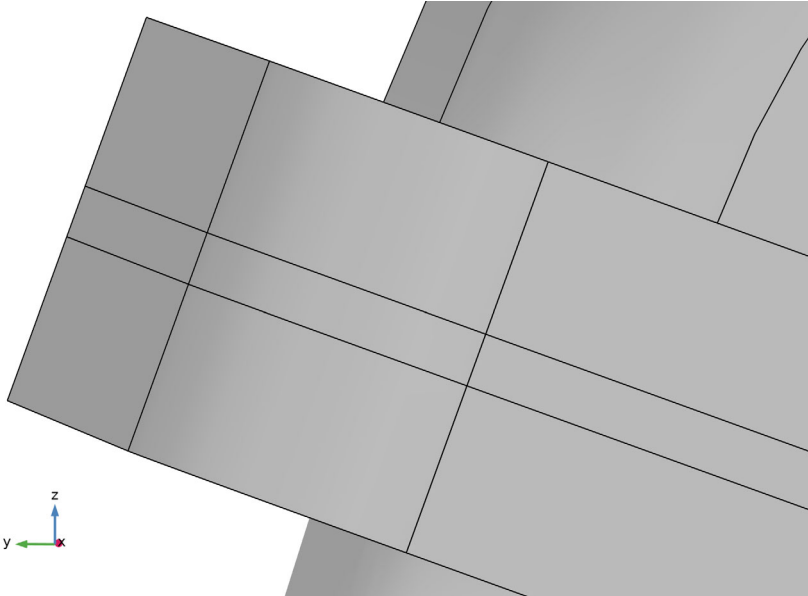

The thin domain is automatically detected and removed by Remove Details.

The removal of the domain is also confirmed in the Information section in the Settings window for Remove Details.

Information	
Type of removal	Removed entities
Ignored vertices	26
Collapsed faces	16
Collapsed domains	1

To understand how the thin domain is removed switch Remove Details to manual mode.

3 In the Remove Details settings window, locate the Mode of operation list. Set it to Manual.

4 In the Model Builder window, expand the Remove Details 1 (rmd1)  node.

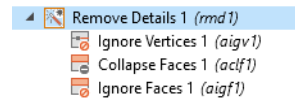

The operation generates and builds a sequence of virtual operations. The thin domain is removed by the last two operations in the sequence: Collapse Faces 1 (aclf1) and Ignore Faces 1 (aigf1). The sliver faces that make up the sides of the thin domain are first collapsed, then one of the interior faces is ignored.

- 5 Click on the Collapse Faces 1 and Ignore Faces 1 nodes in the Model Builder window, then activate their selections to see the input faces highlighted in the Graphics window.

Finally reset Remove Details to automatic mode and generate a mesh for the geometry.

- 6 In the Model Builder window, click Remove Details 1 (rmd1).
- 7 In the Settings window for Remove Details, locate the Mode of operation list and set it to Automatic.
- 8 In the Model Builder window, under Component 1 (comp1) click Mesh 1.
- 9 In the Settings window for Mesh, from the Element size list, choose Fine.
- 10 In the Settings window for Mesh, click  Build All.

