

Whispering Gallery Mode Resonator

Introduction

Waves can be confined around the circumference of a structure and exhibit resonant behavior. This principle is valid for different phenomena and length scales showing that underlying concepts can be applied in very different fields - from the 34 m wide Whispering Gallery in the dome of St Paul's Cathedral, where acoustic waves can travel over large distances, to micrometer sized glass spheres, where light can be confined with extremely low losses due to total reflection. These types of systems are called whispering gallery mode (WGM) resonators.

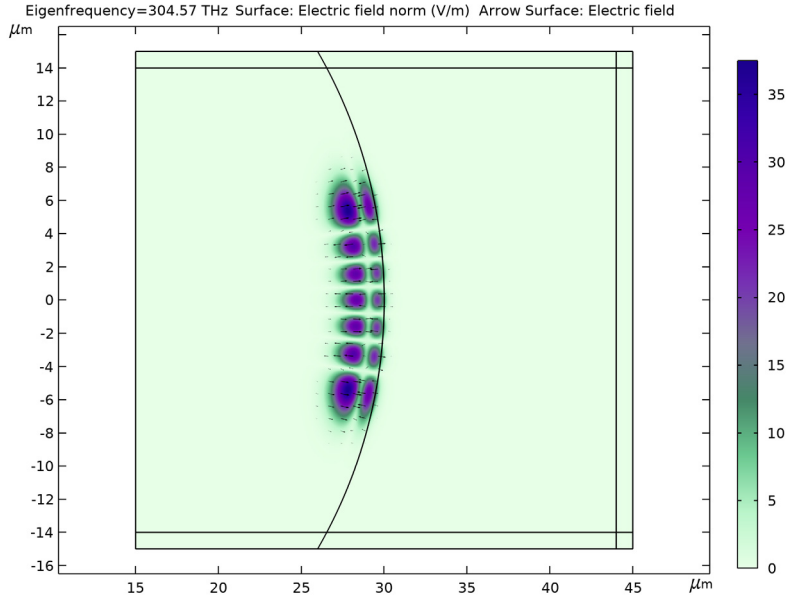

Figure 1: High order polar mode with radial mode number of $l = 2$ of a whispering gallery mode (WGM) resonator. The electric field is confined by total internal reflection at the circumference of a glass sphere.

In this model, we calculate the resonance frequency and spatial mode shape of a glass sphere at optical frequencies, also called a microsphere resonator. The approach described here can also be applied to other types of WGM resonators, like toroid, disk or bottle-type microresonators. These types of devices typically exhibit extremely high optical quality factors (Q-factors), a small mode volume, and strong light-material interactions making them useful tools for nonlinear optics, optomechanics, and sensing applications. Because only approximations for the resonance frequency exist, numerical simulations are essential to get insight into the device behavior and performance.

To validate the microsphere resonator model and to use as an initial frequency guess for the numerical simulation, the approximate resonance frequencies are computed based on a series expansion, discussed in Ref. 1, up to a maximum order of $k_{\max} = 3$.

The highest possible Q-factor is often desirable as it typically increases the interaction strength of interest. The Q-factor of each mode is limited by several loss channels: material, radiative, and scattering (surface roughness and contamination) (compare with Ref. 2). In this model, no surface roughness or contamination is accounted for, so only material losses Q_{mat} and radiative losses Q_{rad} are contributing. The material losses can be computed from the attenuation coefficient of the material

$$\alpha = \frac{4\pi\kappa}{\lambda}, \quad (1)$$

where κ is the imaginary part of the complex refractive index $N = n - j\kappa$. The Q-factor Q_{mat} can be calculated as

$$Q_{\text{mat}} = \frac{2\pi n}{\alpha\lambda}, \quad (2)$$

with its corresponding damping

$$\delta_{\text{mat}} = \frac{\omega}{2Q_{\text{mat}}}. \quad (3)$$

These parameters give some first insight into the Q-factor limits imposed by finite material losses and will be used in the model definition to find the modes of interest.

Model Definition

To efficiently model such a WGM resonator, a 2D axisymmetric approach is used. The 2D axisymmetric version of the Electromagnetic Waves, Frequency Domain supports a non-zero azimuthal mode number n_m such that the electric E field can be written as

$$\mathbf{E}(r, \phi, z) = \mathbf{E}(r, z) \exp(-in_m \phi) \quad (4)$$

Please note that \mathbf{E} is still a three-component vector. The geometry is limited to the area where the modes are located, which helps to reduce the amount of degrees of freedoms in the model. The geometry is surrounded by a Perfectly Matched Layer (PML) to dampen any escaping radiation.

When it comes to meshing, it is advised to manually adjust the mesh for 2D axisymmetric eigenfrequency analysis. The default physics-controlled mesh would mesh the geometry to

resolve the wavelength properly. Here, however, the meshing requirement is only that the transverse mode shapes must be properly resolved.

An Eigenfrequency study step is used to compute the field distribution and the respective complex eigenfrequency $\lambda = -j\omega + \delta$, from which the mode frequency and mode damping δ can be computed. For a resonant structure, you are typically interested in the bound modes in the resonator. It is quite common that unwanted modes, so called spurious modes, exist in the geometry, especially for larger geometries and higher frequencies. This model illustrates two ways, shown in Study 1 and Study 2, how to handle these situations efficiently.

Study 1 uses a spatial filtering method. As it is known that a WGM will be located inside the resonator, we can compare the electric field norm inside and outside of the resonator and filter the modes based on a threshold criterion. This is done using two integration operators defining a variable `ModeLoc`, which is used in the **Combine Solutions** study step to remove spurious modes.

Study 2 uses a region in the complex plane to find only the desired eigenmodes. Each mode represents a point in the complex plane. As the losses are dominated by the material absorption in this configuration and we have an estimation of the resonance frequency range, we can use the region search method of the **Eigenfrequency** study step to find the modes of interest, defined by the real and imaginary part of the eigenvalue λ . The modes of interest will have a small but finite damping, much lower than the spurious modes, which are located outside of the resonator — partly in the absorbing PML.

Study 3 computes the modes for different configurations - three resonator radii, three radial mode number l and the two polarizations (TE and TM). The azimuthal mode number n_m is adjusted to keep the resonance wavelength around 1 μm .

Results and Discussion

Figure 2 shows the Q-factor of all modes in the model in addition to the mode localization. For a mode localization of 1, the field norm is completely located within the resonator domain. The modes with a low Q-factor and a low mode localization number are strongly damped and located outside the resonator and are, thus, not modes of

interest. This information can be used to filter the modes, which is done in the second study step of **Study I**.

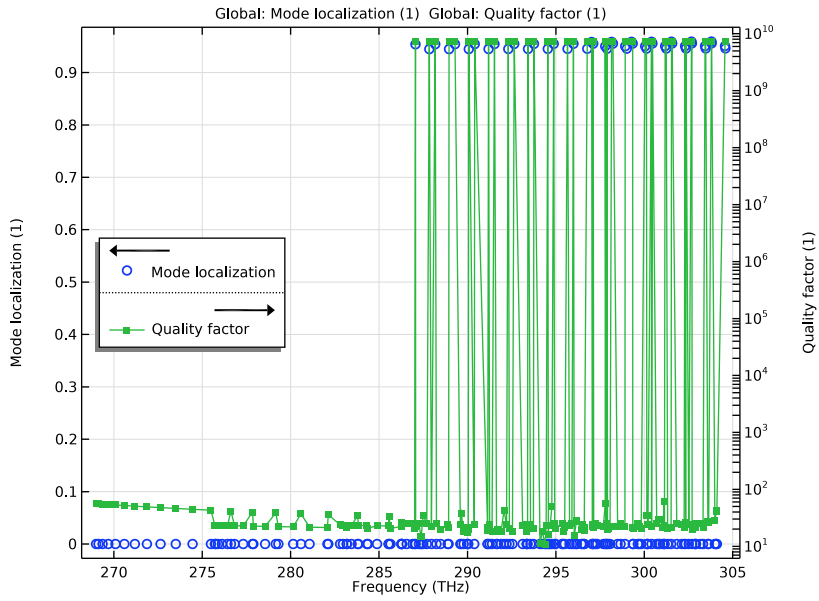

Figure 2: *Q-factor and mode localization of computed modes.*

Figure 3 shows the damping of all modes computed in study 1 (before filtering) and the modes found by the region search in study 2. The region search is setup such that only modes with a damping lower than the threshold are searched for. The frequency and

damping of the modes of interest is identical although different methods are used to find them.

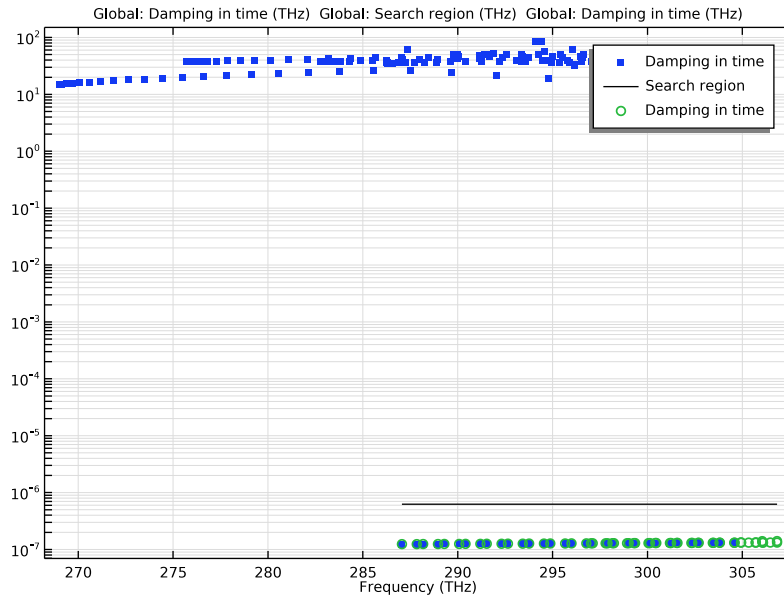

Figure 3: Blue points correspond to the damping of all modes found in study 1 and include spurious modes. The back line is the upper limit for the damping (imaginary part of the eigenvalue) in the region search. Therefore, only modes with a lower damping are found in study 2 (green circles).

Figure 4 shows that for large radii, the Q-factor is limited by the material loss (dashed line). For a small radius of $r = 10 \mu\text{m}$, radiative losses become the dominant loss factor, leading to a further reduction of the Q-factor.

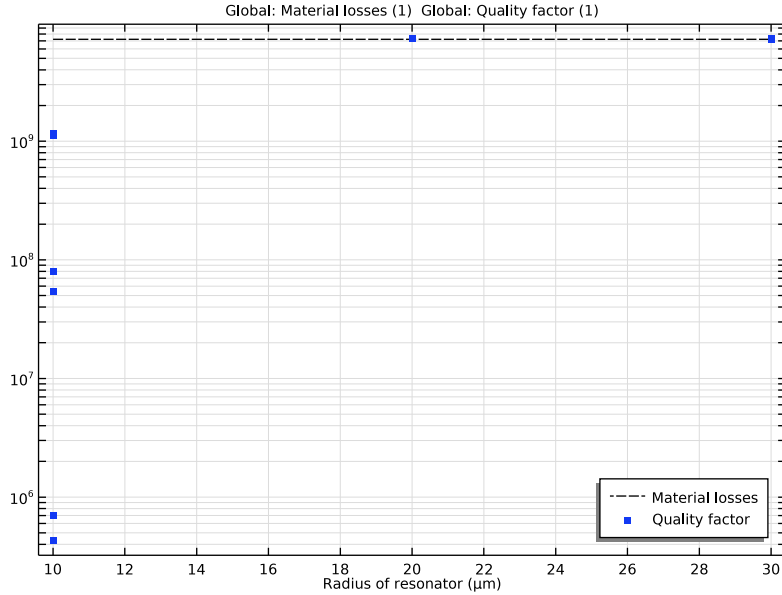

Figure 4: Q-factor for different modes and radii. The dashed line corresponds to the Q-factor limit by the material absorption.

Figure 5 shows a 3D representation of the resonator mode using the Revolution 2D dataset.

r_res=10, n_m=80, p=1, l=3 Eigenfrequency=327.08 THz Multislice: Electric field norm (V/m) Arrow Volume:
Isosurface: ewfd.Ephi*exp(-i*n_m*rev3phi)

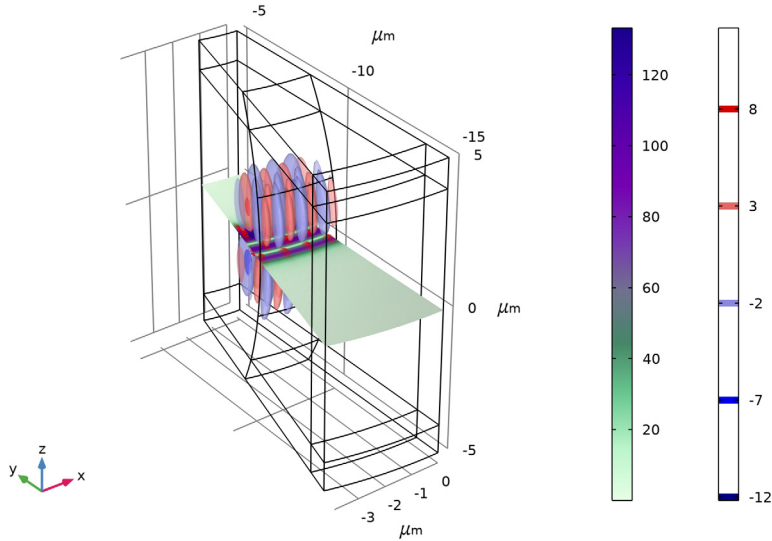

Figure 5: Reconstructed mode from the 2D axisymmetric solution. The electric field direction is represented by red arrows, the surface plots show the electric field norm while the contour plot illustrates the \vec{E}_ϕ .

References

1. S. Schiller, "Asymptotic expansion of morphological resonance frequencies in Mie scattering," *Appl. Opt.*, vol. 32, pp. 2181–2185, 1993.
2. M. Gorodetsky, A. Savchenkov, and V. Ilchenko, "Ultimate Q of optical microsphere resonators," *Opt. Lett.*, vol. 21, pp. 453–455, 1996.

Application Library path: Wave_Optics_Module/Verification_Examples/
whispering_gallery_mode_resonator



Modeling Instructions

From the **File** menu, choose **New**.

NEW

In the **New** window, click  **Model Wizard**.

MODEL WIZARD



- 1 In the **Model Wizard** window, click  **2D Axisymmetric**.
- 2 In the **Select Physics** tree, select **Optics>Wave Optics>Electromagnetic Waves, Frequency Domain (ewfd)**.
- 3 Click **Add**.
- 4 Click  **Study**.
- 5 In the **Select Study** tree, select **General Studies>Eigenfrequency**.
- 6 Click  **Done**.

GLOBAL DEFINITIONS



Resonator Parameters

- 1 In the **Model Builder** window, under **Global Definitions** click **Parameters I**.
- 2 In the **Settings** window for **Parameters**, type Resonator Parameters in the **Label** text field.
- 3 Locate the **Parameters** section. Click  **Load from File**.
- 4 Browse to the model's Application Libraries folder and double-click the file `whispering_gallery_mode_resonator_resonator_parameters.txt`.

Analytic Higher Order Approximation - Schiller



- 1 In the **Home** toolbar, click  **Parameters** and choose **Add>Parameters**.
- 2 In the **Settings** window for **Parameters**, type Analytic Higher Order Approximation - Schiller in the **Label** text field.
- 3 Locate the **Parameters** section. Click  **Load from File**.
- 4 Browse to the model's Application Libraries folder and double-click the file `whispering_gallery_mode_resonator_analytic_higher_order_approximation_parameters.txt`.

Airy Function Zeroes

- 1 In the **Home** toolbar, click  **Functions** and choose **Global>Interpolation**.
- 2 In the **Settings** window for **Interpolation**, type Airy Function Zeroes in the **Label** text field.
- 3 Locate the **Definition** section. In the **Function name** text field, type A_i .
- 4 Click  **Load from File**.

- 5 Browse to the model's Application Libraries folder and double-click the file `whispering_gallery_mode_resonator_airy_function_zeroes.txt`.

Piecewise 1 (pw1)

- 1 In the **Home** toolbar, click  **Functions** and choose **Global>Piecewise**.
- 2 In the **Settings** window for **Piecewise**, type `dk` in the **Function name** text field.
- 3 Locate the **Definition** section. Find the **Intervals** subsection. Click  **Load from File**.
- 4 Browse to the model's Application Libraries folder and double-click the file `whispering_gallery_mode_resonator_piecewise_function.txt`.

GEOMETRY 1

- 1 In the **Model Builder** window, under **Component 1 (comp1)** click **Geometry 1**.
- 2 In the **Settings** window for **Geometry**, locate the **Units** section.
- 3 From the **Length unit** list, choose **μm** .

Rectangle 1 (r1)

- 1 In the **Geometry** toolbar, click  **Rectangle**.
- 2 In the **Settings** window for **Rectangle**, locate the **Size and Shape** section.
- 3 In the **Width** text field, type `r_air-r_cut`.
- 4 In the **Height** text field, type `h_air`.
- 5 Locate the **Position** section. In the **r** text field, type `r_cut`.
- 6 In the **z** text field, type `-h_air/2`.
- 7 Click to expand the **Layers** section. In the table, enter the following settings:



Layer name	Thickness (μm)
Layer 1	t_PML

- 8 Select the **Layers to the right** check box.
- 9 Select the **Layers on top** check box.

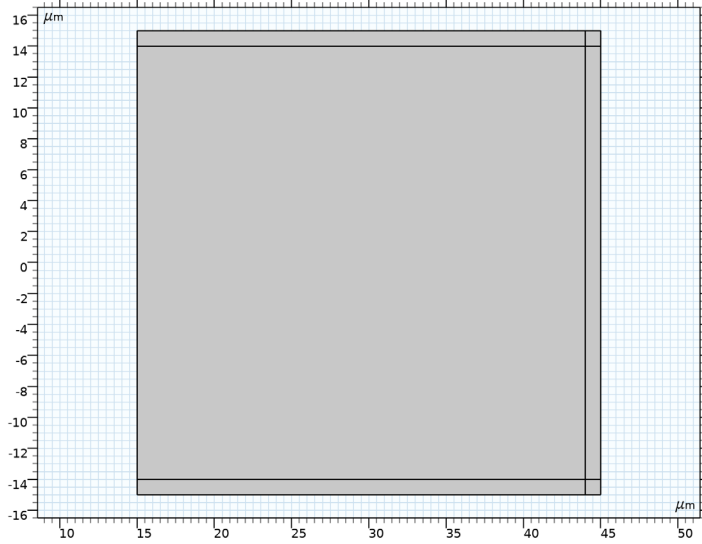
10 Click  **Build Selected.**



Circle 1 (c1)

- 1 In the **Geometry** toolbar, click  **Circle.**
- 2 In the **Settings** window for **Circle**, locate the **Size and Shape** section.
- 3 In the **Radius** text field, type r_res.
- 4 Locate the **Rotation Angle** section. In the **Rotation** text field, type 45.
- 5 Click  **Build Selected.**

6 Click the  **Zoom Extends** button in the **Graphics** toolbar.

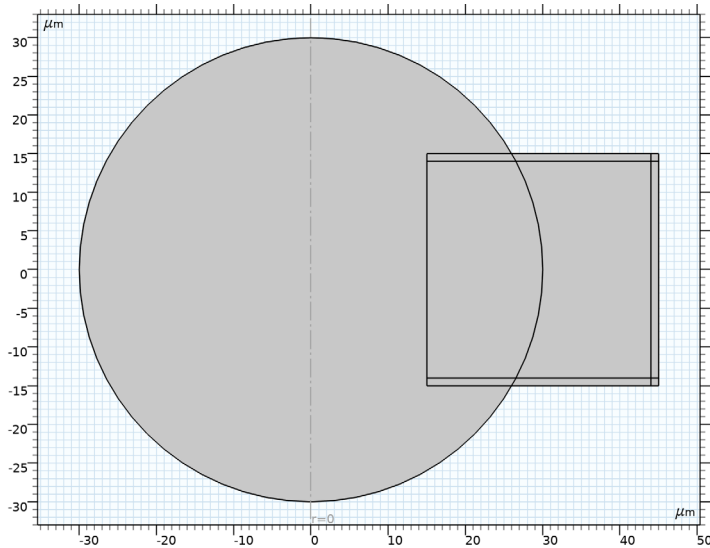

Union 1 (un1)

- 1 In the **Geometry** toolbar, click  **Booleans and Partitions** and choose **Union**.
- 2 Click in the **Graphics** window and then press Ctrl+A to select both objects. Alternatively, you can left-click on the circle and the rectangle to add them to the **Union** selection

3 In the **Settings** window for **Union**, click  **Build Selected**.

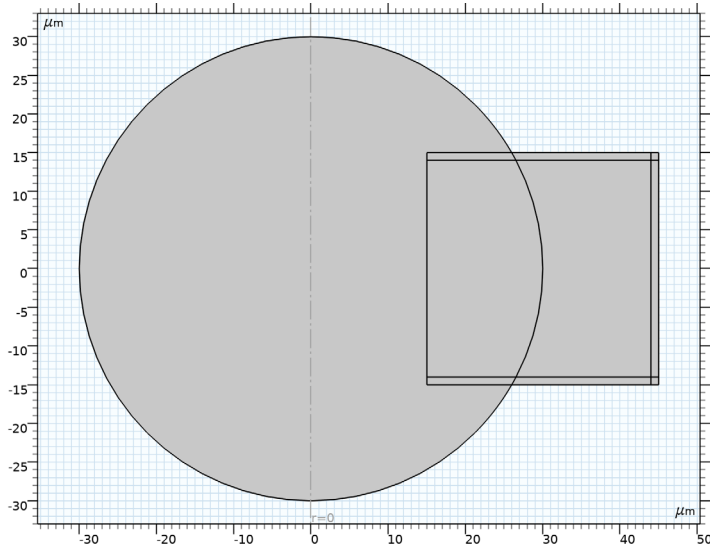

Delete Entities 1 (dell)

1 In the **Geometry** toolbar, click  **Delete**.

2 In the **Settings** window for **Delete Entities**, locate the **Entities or Objects to Delete** section.

3 From the **Geometric entity level** list, choose **Domain**.

4 On the object **unil**, select Domain 1 only.

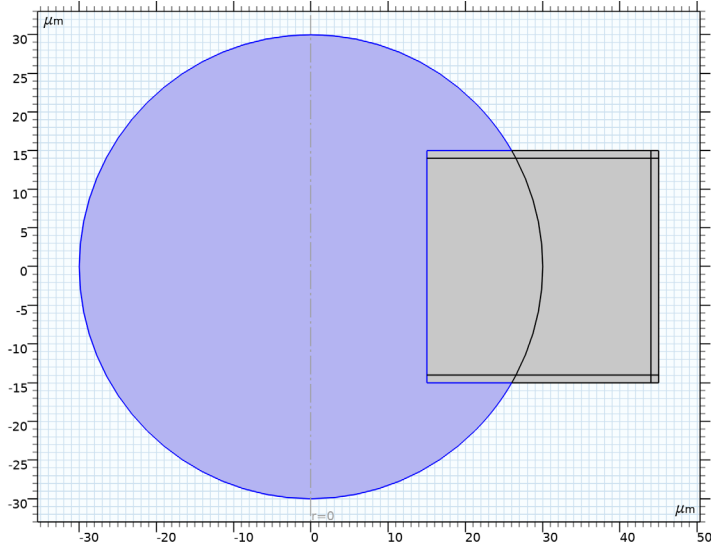

5 Click  **Build All Objects**.

6 Click the  **Zoom Extents** button in the **Graphics** toolbar.

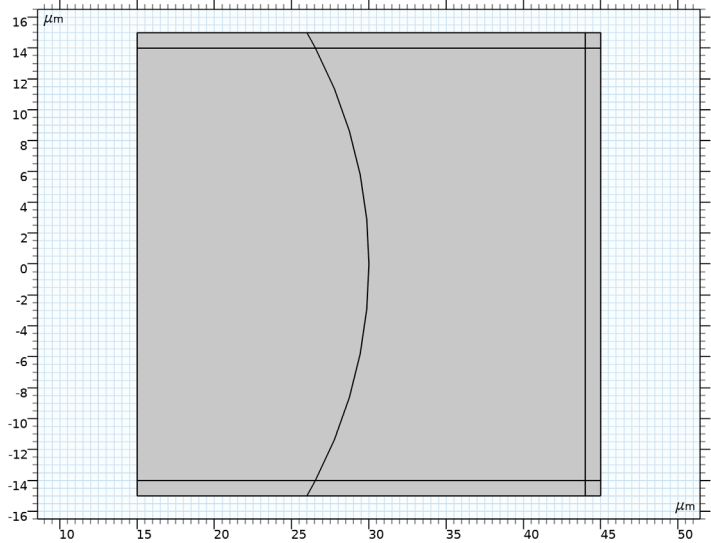

Partition Edges 1 (pare1)

In order to have more control over the mesh, we can partition the outer edge to later refine the mesh close to where the mode will be located.

- 1 In the **Geometry** toolbar, click  **Booleans and Partitions** and choose **Partition Edges**.
- 2 On the object **dell**, select Boundary 24 only.

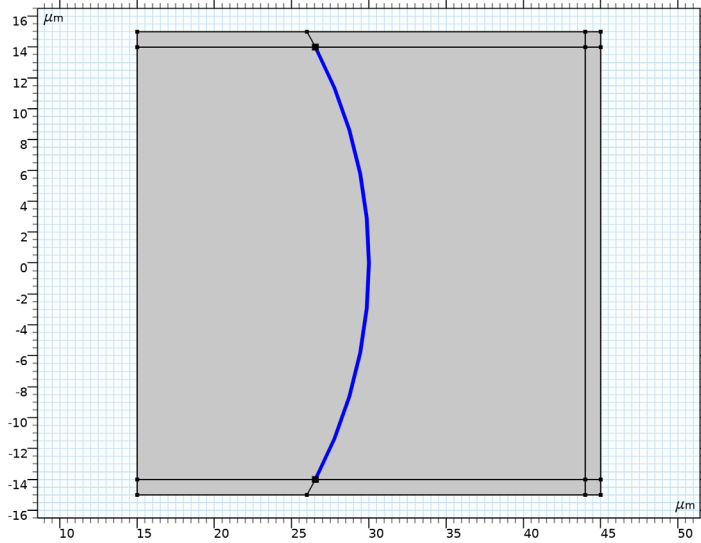

- 3 In the **Settings** window for **Partition Edges**, locate the **Positions** section.
- 4 In the table, enter the following settings:

Relative arc length parameters
0.25
0.75

5 In the **Geometry** toolbar, click  **Build All**.

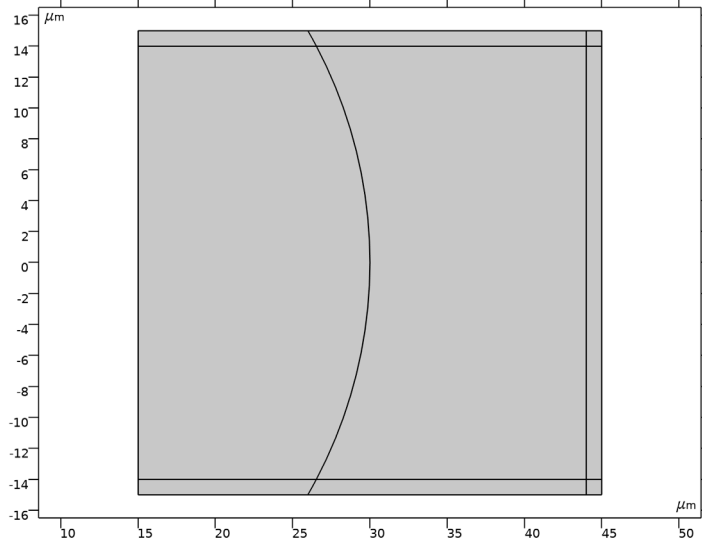

MATERIALS

Host Medium

- 1 In the **Model Builder** window, under **Component 1 (comp1)** right-click **Materials** and choose **Blank Material**.
- 2 In the **Settings** window for **Material**, type Host Medium in the **Label** text field.
- 3 Locate the **Material Contents** section. In the table, enter the following settings:

Property	Variable	Value	Unit	Property group
Refractive index, real part	n_{iso} ; $n_{ii} = n_{iso}$, $n_{ij} = 0$	n_a	1	Refractive index
Refractive index, imaginary part	k_{iiso} ; $k_{iii} =$ k_{iiso} , $k_{ij} = 0$	0	1	Refractive index

Sphere

- 1 Right-click **Materials** and choose **Blank Material**.
- 2 In the **Settings** window for **Material**, type Sphere in the **Label** text field.

3 Select Domains 1–3 only.

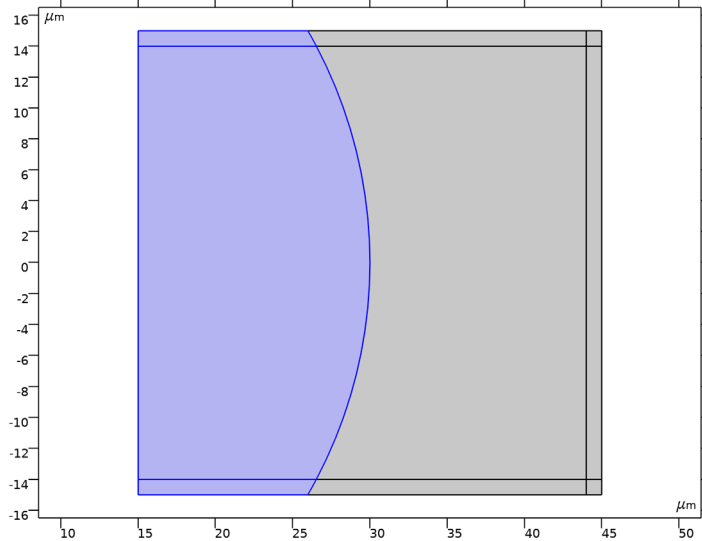

4 Locate the **Material Contents** section. In the table, enter the following settings:

Property	Variable	Value	Unit	Property group
Refractive index, real part	n_{iso} ; $n_{ii} = n_{iso}$, $n_{ij} = 0$	n_{res}	l	Refractive index
Refractive index, imaginary part	k_{iso} ; $k_{iii} =$ k_{iso} , $k_{ij} = 0$	k_{res}	l	Refractive index

ELECTROMAGNETIC WAVES, FREQUENCY DOMAIN (EWFD)

- 1 In the **Model Builder** window, under **Component 1 (comp1)** click **Electromagnetic Waves, Frequency Domain (ewfd)**.
- 2 In the **Settings** window for **Electromagnetic Waves, Frequency Domain**, locate the **Out-of-Plane Wave Number** section.
- 3 In the m text field, type n_m .

DEFINITIONS

Integration 1 (intop1)

- 1 In the **Definitions** toolbar, click  **Nonlocal Couplings** and choose **Integration**.
- 2 In the **Settings** window for **Integration**, type res in the **Operator name** text field.

3 Select Domain 2 only.

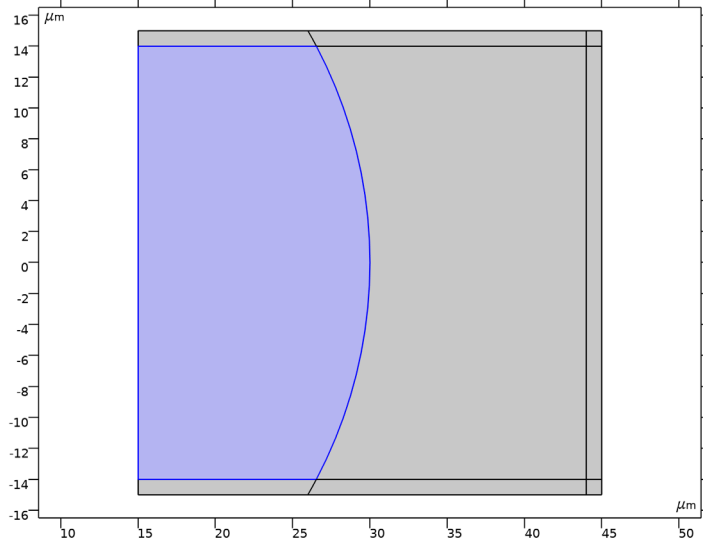

Integration 2 (intop2)

- 1 In the **Definitions** toolbar, click  **Nonlocal Couplings** and choose **Integration**.
- 2 In the **Settings** window for **Integration**, type **air** in the **Operator name** text field.
- 3 Select Domain 6 only.

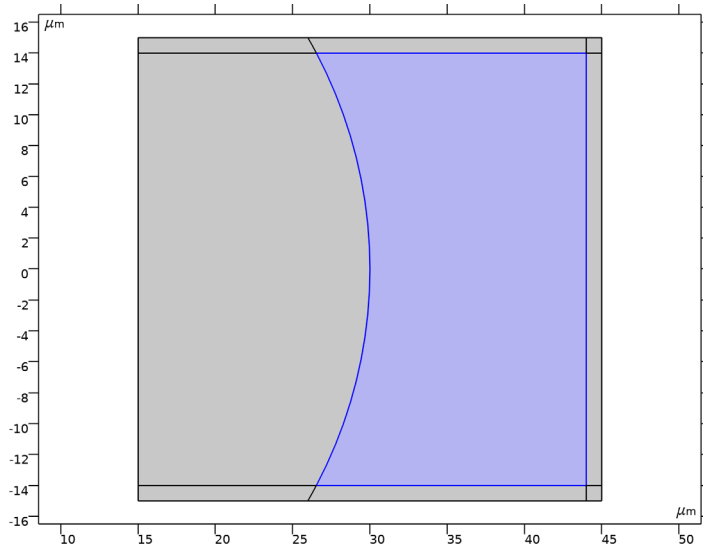

Variables 1

- 1 In the **Model Builder** window, right-click **Definitions** and choose **Variables**.
- 2 In the **Settings** window for **Variables**, locate the **Variables** section.
- 3 In the table, enter the following settings:

Name	Expression	Unit	Description
ModeLoc	$\text{res}(\text{ewfd.normE}) / (\text{res}(\text{ewfd.normE}) + \text{air}(\text{ewfd.normE}))$		Mode localization

This globally available variable will be used to filter the modes based on their location.

Perfectly Matched Layer 1 (pml1)

- 1 In the **Definitions** toolbar, click  **Perfectly Matched Layer**.
- 2 Select Domains 1, 3–5, and 7–9 only.

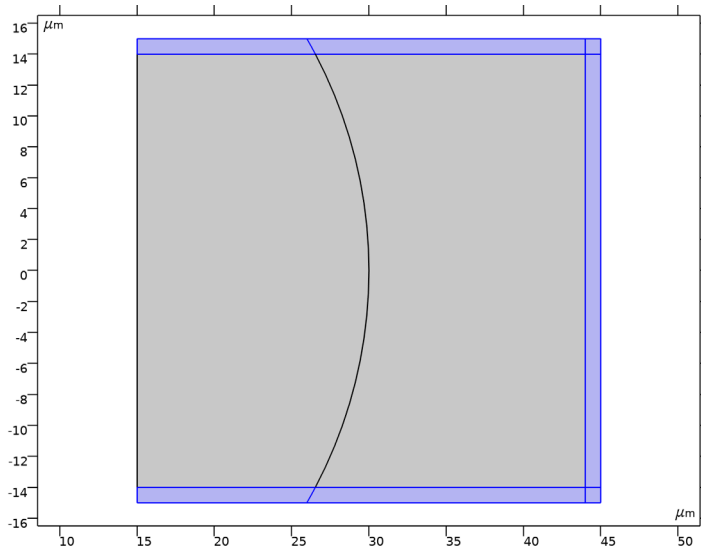

- 3 In the **Settings** window for **Perfectly Matched Layer**, locate the **Geometry** section.
- 4 From the **Type** list, choose **Cylindrical**.

MESH 1

- 1 In the **Model Builder** window, under **Component 1 (comp1)** click **Mesh 1**.
- 2 In the **Settings** window for **Mesh**, locate the **Sequence Type** section.
- 3 From the list, choose **User-controlled mesh**.

Size

- 1 In the **Model Builder** window, under **Component 1 (comp1)>Mesh 1** click **Size**.
- 2 In the **Settings** window for **Size**, locate the **Element Size Parameters** section.
- 3 In the **Maximum element size** text field, type 1.25.
- 4 In the **Minimum element size** text field, type 0.1.

Size 1

- 1 In the **Model Builder** window, click **Size 1**.
- 2 In the **Settings** window for **Size**, locate the **Element Size Parameters** section.
- 3 In the **Maximum element size** text field, type 1.
- 4 In the **Minimum element size** text field, type 0.009.
- 5 In the **Maximum element growth rate** text field, type 1.04.

Size 2

Now, add another size node to refine the mesh at the outer boundary. This will help resolve the mode shape in the resonator and the exponential decay of the field in the air domain.

- 1 In the **Model Builder** window, right-click **Mesh 1** and choose **Size**.
- 2 Drag and drop **Size 2** below **Size 1**.
- 3 In the **Settings** window for **Size**, locate the **Geometric Entity Selection** section.
- 4 From the **Geometric entity level** list, choose **Boundary**.

5 Select Boundary 26 only.

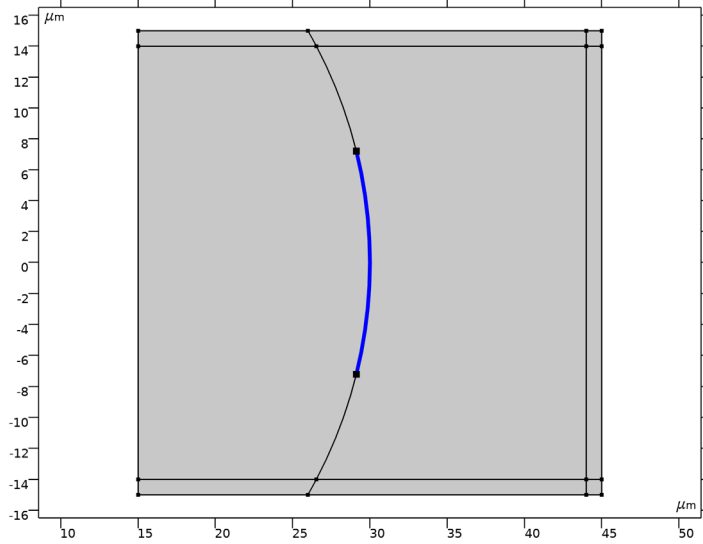

6 Locate the **Element Size** section. Click the **Custom** button.

7 Locate the **Element Size Parameters** section. Select the **Maximum element size** check box.

8 In the associated text field, type 0.15.

9 Click  **Build All**.

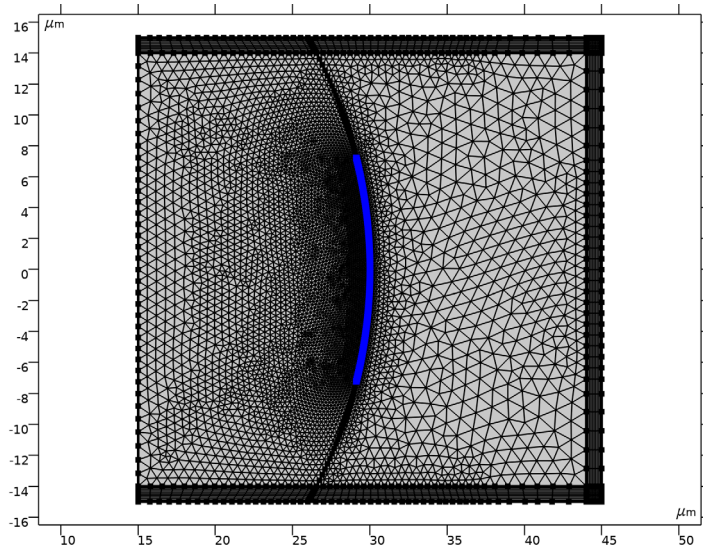

FILTERED EIGENFREQUENCY STUDY



This first study will demonstrate how to use the Combine solution feature to filter out unwanted, non-bound, modes.

- 1 In the **Model Builder** window, click **Study 1**.
- 2 In the **Settings** window for **Study**, type Filtered Eigenfrequency Study in the **Label** text field.

Step 1: Eigenfrequency

- 1 In the **Model Builder** window, under **Filtered Eigenfrequency Study** click **Step 1: Eigenfrequency**.
- 2 In the **Settings** window for **Eigenfrequency**, locate the **Study Settings** section.
- 3 Select the **Desired number of eigenfrequencies** check box.
- 4 In the associated text field, type 200.
- 5 In the **Search for eigenfrequencies around** text field, type f_{res} .

Combine Solutions

- 1 In the **Study** toolbar, click  **Combine Solutions**.
- 2 In the **Settings** window for **Combine Solutions**, locate the **Combine Solutions Settings** section.
- 3 From the **Solution operation** list, choose **Remove solutions**.
- 4 From the **Exclude or include** list, choose **Include**.
- 5 From the **Include method** list, choose **Implicit**.
- 6 In the **Included if** text field, type $comp1.ModeLoc > 0.5$. This filters the modes in the solution based on the localization using a threshold value.
- 7 In the **Study** toolbar, click  **Compute**.

RESULTS

Electric Field - Filtered Modes

In the **Settings** window for **2D Plot Group**, type Electric Field - Filtered Modes in the **Label** text field.

Surface 1

- 1 In the **Model Builder** window, expand the **Electric Field - Filtered Modes** node, then click **Surface 1**.
- 2 In the **Settings** window for **Surface**, locate the **Coloring and Style** section.
- 3 From the **Color table** list, choose **AuroraBorealis**.

Arrow Surface 1

- 1 In the **Model Builder** window, right-click **Electric Field - Filtered Modes** and choose **Arrow Surface**.
- 2 In the **Settings** window for **Arrow Surface**, click **Replace Expression** in the upper-right corner of the **Expression** section. From the menu, choose **Component 1 (comp1)> Electromagnetic Waves, Frequency Domain>Electric>ewfd.Er,ewfd.Ez - Electric field**.
- 3 Locate the **Arrow Positioning** section. Find the **R grid points** subsection. In the **Points** text field, type 40.
- 4 Find the **Z grid points** subsection. In the **Points** text field, type 40.
- 5 Locate the **Coloring and Style** section. From the **Arrow length** list, choose **Logarithmic**.
- 6 From the **Color** list, choose **Black**.
- 7 In the **Electric Field - Filtered Modes** toolbar, click  **Plot**.

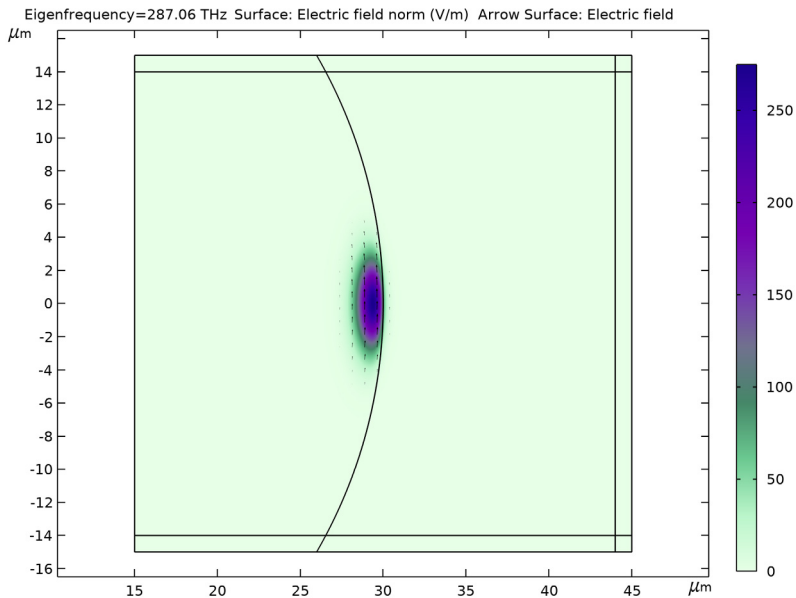

This plot shows the lowest order whispering gallery mode, for the selected azimuthal mode number. The arrow plot indicates that the field is polarized in the z direction.

Mode Localization

- 1 In the **Home** toolbar, click  **Add Plot Group** and choose **ID Plot Group**.
- 2 In the **Settings** window for **ID Plot Group**, type **Mode Localization** in the **Label** text field.

- 3 Locate the **Data** section. From the **Dataset** list, choose **Filtered Eigenfrequency Study/ Solution Store 1 (sol2)**.
- 4 Locate the **Plot Settings** section. Select the **Two y-axes** check box.
- 5 Locate the **Axis** section. Select the **Secondary y-axis log scale** check box.

Global 1

- 1 In the **Mode Localization** toolbar, click  **Global**.
- 2 In the **Settings** window for **Global**, locate the **y-Axis Data** section.
- 3 In the table, enter the following settings:

Expression	Unit	Description
ModeLoc	1	Mode localization

- 4 Locate the **x-Axis Data** section. From the **Parameter** list, choose **Expression**.
- 5 In the **Expression** text field, type `ewfd.freq`.
- 6 From the **Unit** list, choose **THz**.
- 7 Click to expand the **Coloring and Style** section. Find the **Line style** subsection. From the **Line** list, choose **None**.
- 8 Find the **Line markers** subsection. From the **Marker** list, choose **Circle**.
- 9 From the **Positioning** list, choose **In data points**.

Mode Localization

In the **Model Builder** window, click **Mode Localization**.

Global 2

- 1 In the **Mode Localization** toolbar, click  **Global**.
- 2 In the **Settings** window for **Global**, locate the **y-Axis** section.
- 3 Select the **Plot on secondary y-axis** check box.
- 4 Locate the **y-Axis Data** section. In the table, enter the following settings:

Expression	Unit	Description
ewfd.Qfactor	1	Quality factor

- 5 Locate the **x-Axis Data** section. From the **Parameter** list, choose **Expression**.
- 6 In the **Expression** text field, type `ewfd.freq`.
- 7 From the **Unit** list, choose **THz**.

- 8 Locate the **Coloring and Style** section. Find the **Line markers** subsection. From the **Marker** list, choose **Point**.
- 9 From the **Positioning** list, choose **In data points**.

Mode Localization

- 1 In the **Model Builder** window, click **Mode Localization**.
- 2 In the **Settings** window for **ID Plot Group**, locate the **Legend** section.
- 3 From the **Position** list, choose **Middle left**.
- 4 In the **Mode Localization** toolbar, click  **Plot**.

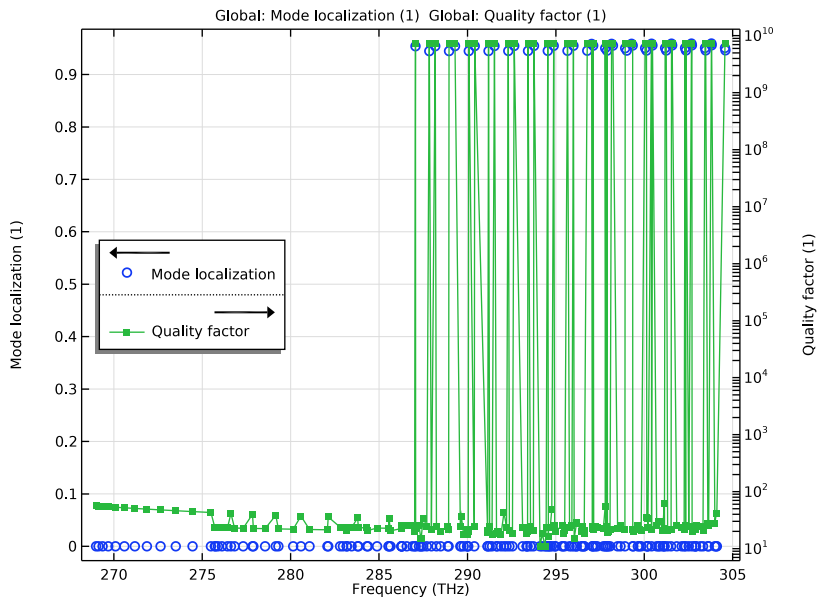

This plot shows that a model localization factor of 0.5 can be efficiently used to discriminate between the whispering gallery modes, having a large Q-factor, and the unwanted modes, localized in the surrounding air and having a low Q-factor.

Electric Field - All Modes

- 1 In the **Model Builder** window, right-click **Electric Field - Filtered Modes** and choose **Duplicate**.
- 2 In the **Settings** window for **2D Plot Group**, type Electric Field - All Modes in the **Label** text field.
- 3 Locate the **Data** section. From the **Dataset** list, choose **Filtered Eigenfrequency Study/ Solution Store 1 (sol2)**.

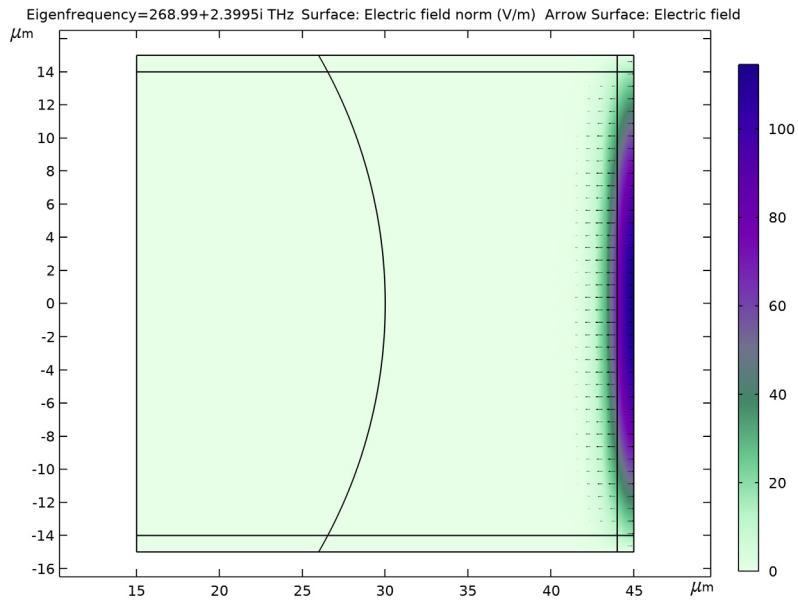

4 In the **Electric Field - All Modes** toolbar, click  **Plot**.



This plot visualizes all modes, including the unwanted modes localized in the surrounding air domain.

ADD STUDY

The second study will demonstrate how to use the Region method in the Eigenfrequency solver to filter out unwanted, non-bound, modes.

- 1 In the **Home** toolbar, click  **Add Study** to open the **Add Study** window.
- 2 Go to the **Add Study** window.
- 3 Find the **Studies** subsection. In the **Select Study** tree, select **General Studies> Eigenfrequency**.
- 4 Click **Add Study** in the window toolbar.
- 5 In the **Home** toolbar, click  **Add Study** to close the **Add Study** window.

EIGENFREQUENCY REGION SEARCH

- 1 In the **Model Builder** window, click **Study 2**.
- 2 In the **Settings** window for **Study**, type Eigenfrequency Region Search in the **Label** text field.

Step 1: Eigenfrequency

- 1 In the **Model Builder** window, under **Eigenfrequency Region Search** click **Step 1: Eigenfrequency**.
- 2 In the **Settings** window for **Eigenfrequency**, locate the **Study Settings** section.
- 3 From the **Eigenfrequency search method** list, choose **Region**.
- 4 In the **Approximate number of eigenfrequencies** text field, type 100.
- 5 Find the **Search region** subsection. In the **Smallest real part** text field, type $f_{res}-5[\text{THz}]$.
- 6 In the **Largest real part** text field, type $f_{res}+20[\text{THz}]$.
- 7 In the **Largest imaginary part** text field, type $(damp+500[\text{kHz}])/(2*\pi)$.
- 8 In the **Home** toolbar, click  **Compute**.

RESULTS

Electric Field - Region Search

- 1 In the **Settings** window for **2D Plot Group**, type **Electric Field - Region Search** in the **Label** text field.
- 2 Locate the **Data** section. From the **Eigenfrequency (THz)** list, choose **299.29**.

Surface 1

- 1 In the **Model Builder** window, expand the **Electric Field - Region Search** node, then click **Surface 1**.
- 2 In the **Settings** window for **Surface**, locate the **Coloring and Style** section.
- 3 From the **Color table** list, choose **AuroraBorealis**.

Arrow Surface 1

Now, we can copy the Arrow Surface plot we created earlier.

In the **Model Builder** window, under **Results>Electric Field - Filtered Modes** right-click **Arrow Surface 1** and choose **Copy**.

Arrow Surface 1

- 1 In the **Model Builder** window, right-click **Electric Field - Region Search** and choose **Paste Arrow Surface**.

2 In the **Electric Field - Region Search** toolbar, click  **Plot**.

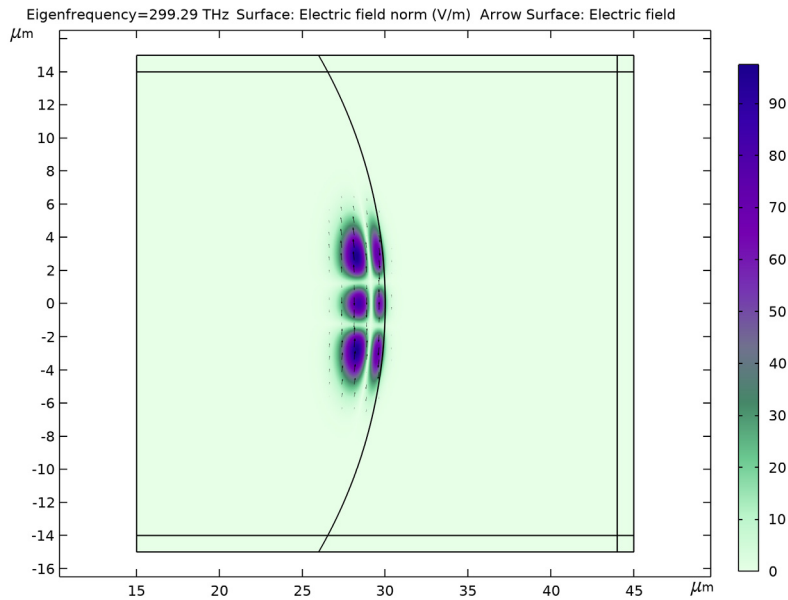

It is clear from these plots that the eigenfrequency region search method only returns the wanted whispering gallery modes.

Mode Localization

To show the filtered mode spectrum, we can copy the 1D plot group we previously created.

Filter Criterion

- 1 In the **Model Builder** window, right-click **Mode Localization** and choose **Duplicate**.
- 2 In the **Settings** window for **1D Plot Group**, type **Filter Criterion** in the **Label** text field.
- 3 Locate the **Plot Settings** section. Clear the **Two y-axes** check box.
- 4 Locate the **Axis** section. Select the **y-axis log scale** check box.
- 5 Locate the **Legend** section. From the **Position** list, choose **Upper right**.

Global 1

- 1 In the **Model Builder** window, expand the **Filter Criterion** node, then click **Global 1**.

- 2 In the **Settings** window for **Global**, click **Replace Expression** in the upper-right corner of the **y-Axis Data** section. From the menu, choose **Component 1 (comp1)> Electromagnetic Waves, Frequency Domain>ewfd.damp - Damping in time - Hz**.
- 3 Locate the **y-Axis Data** section. In the table, enter the following settings:

Expression	Unit	Description
ewfd.damp	THz	Damping in time

- 4 Locate the **Coloring and Style** section. Find the **Line markers** subsection. From the **Marker** list, choose **Point**.

Global 2

- 1 In the **Model Builder** window, click **Global 2**.
- 2 In the **Settings** window for **Global**, locate the **Data** section.
- 3 From the **Dataset** list, choose **Eigenfrequency Region Search/Solution 3 (sol3)**.
Now, replace the quality factor, `ewfd.Qfactor`, with a search region expression.
- 4 Locate the **y-Axis Data** section. In the table, enter the following settings:

Expression	Unit	Description
(damp+500 [kHz])	THz	Search region

- 5 Locate the **Coloring and Style** section. From the **Color** list, choose **Black**.
- 6 Find the **Line markers** subsection. From the **Marker** list, choose **None**.

Global 3

- 1 In the **Model Builder** window, under **Results>Filter Criterion** right-click **Global 1** and choose **Duplicate**.
- 2 In the **Settings** window for **Global**, locate the **Data** section.
- 3 From the **Dataset** list, choose **Eigenfrequency Region Search/Solution 3 (sol3)**.
- 4 Locate the **Coloring and Style** section. Find the **Line markers** subsection. From the **Marker** list, choose **Circle**.

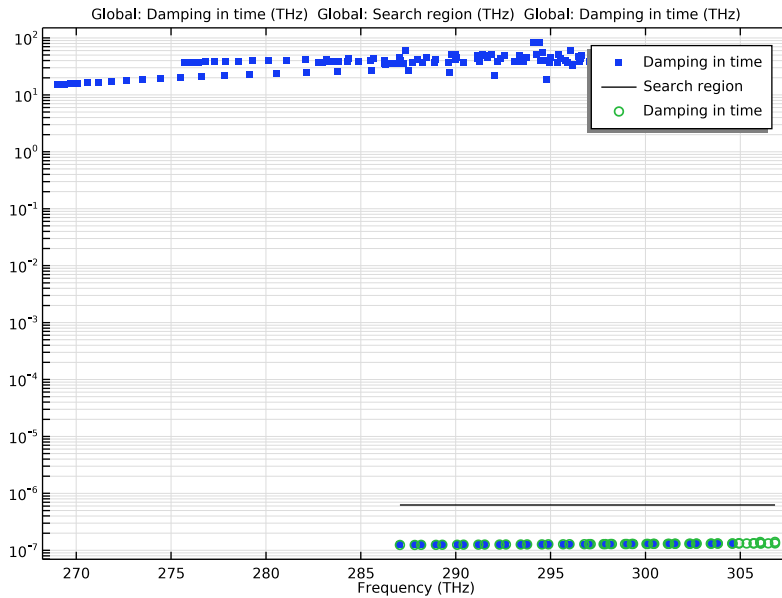

5 In the **Filter Criterion** toolbar, click  **Plot**.



This plot indicates that the damping can be used with the eigenfrequency region search method, to discriminate between the whispering gallery modes and the modes located in the surrounding air. The solid line shows the threshold value. It is clear that the whispering gallery modes from both the first study (blue circles) and second study (green circles) fall below this threshold value.

ADD STUDY

In the final, third, study, parametric sweeps will be used together with the Eigenfrequency solver to show the solutions from some resonator configurations.

- 1 In the **Home** toolbar, click  **Add Study** to open the **Add Study** window.
- 2 Go to the **Add Study** window.
- 3 Find the **Studies** subsection. In the **Select Study** tree, select **General Studies> Eigenfrequency**.
- 4 Click **Add Study** in the window toolbar.
- 5 In the **Home** toolbar, click  **Add Study** to close the **Add Study** window.

PARAMETRIC SWEEP EIGENFREQUENCY STUDY

- 1 In the **Model Builder** window, click **Study 3**.

- In the **Settings** window for **Study**, type Parametric Sweep Eigenfrequency Study in the **Label** text field.

Step 1: Eigenfrequency

- In the **Model Builder** window, under **Parametric Sweep Eigenfrequency Study** click **Step 1: Eigenfrequency**.
- In the **Settings** window for **Eigenfrequency**, locate the **Study Settings** section.
- Select the **Desired number of eigenfrequencies** check box.
- In the associated text field, type 1.
- In the **Search for eigenfrequencies around** text field, type f_{res} .

Parametric Sweep

- In the **Study** toolbar, click  **Parametric Sweep**.
- In the **Settings** window for **Parametric Sweep**, locate the **Study Settings** section.
- Click **+ Add**.
- In the table, enter the following settings:

Parameter name	Parameter value list	Parameter unit
r_res (Radius of resonator)	10 20 30	um

- Click **+ Add**.
- In the table, enter the following settings:

Parameter name	Parameter value list	Parameter unit
n_m (Azimuthal mode number)	80 165 250	

Parametric Sweep 2

- In the **Study** toolbar, click  **Parametric Sweep**.
- Drag and drop below **Parametric Sweep**, to make **Parametric Sweep 2** appear below **Parametric Sweep**.

Now, define the sweeps for **Parametric Sweep 2**.

- In the **Settings** window for **Parametric Sweep**, locate the **Study Settings** section.
- Click **+ Add**.
- In the table, enter the following settings:

Parameter name	Parameter value list	Parameter unit
p (l for TE, l/m^2 for TM)	1 $1/m^2$	

6 Click  **Add**.

7 In the table, enter the following settings:

Parameter name	Parameter value list	Parameter unit
l (Radial mode number)	1 2 3	

8 From the **Sweep type** list, choose **All combinations**.

9 In the **Study** toolbar, click  **Compute**.

RESULTS

Electric Field - Different Configurations

- 1 In the **Settings** window for **2D Plot Group**, type **Electric Field - Different Configurations** in the **Label** text field.
- 2 Locate the **Data** section. From the **Parameter value (r_res (um),n_m,p)** list, choose **2: r_res=10 um, n_m=80, p=0.47846**.
- 3 From the **Parameter value (l)** list, choose **2**.

Surface 1

- 1 In the **Model Builder** window, expand the **Electric Field - Different Configurations** node, then click **Surface 1**.
- 2 In the **Settings** window for **Surface**, locate the **Coloring and Style** section.
- 3 From the **Color table** list, choose **AuroraBorealis**.

Arrow Surface 1

In the **Model Builder** window, under **Results>Electric Field - Region Search** right-click **Arrow Surface 1** and choose **Copy**.

Arrow Surface 1

- 1 In the **Model Builder** window, right-click **Electric Field - Different Configurations** and choose **Paste Arrow Surface**.
- 2 Click the  **Zoom Extents** button in the **Graphics** toolbar.

3 In the **Electric Field - Different Configurations** toolbar, click  **Plot**.

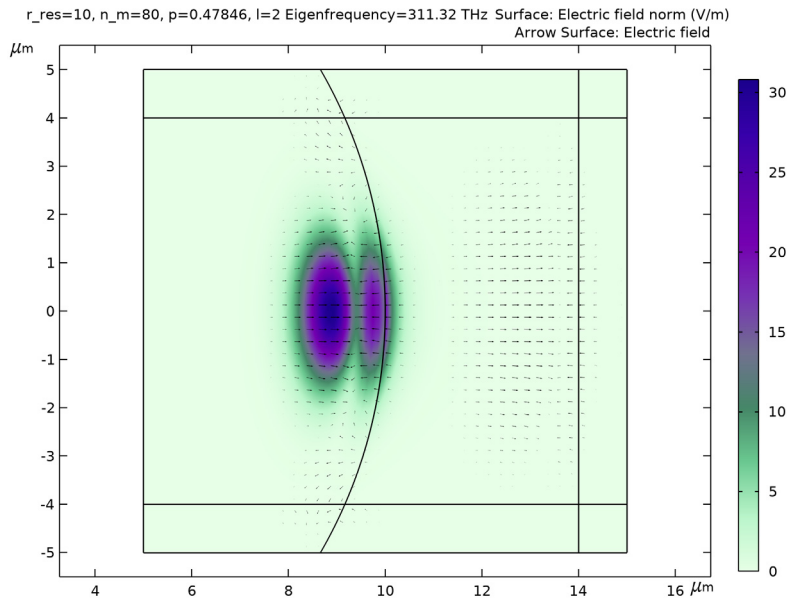

In this plot group, you can visualize the whispering gallery modes for some resonator configurations.

3D Sector

Next, use the available revolution dataset to make a 3D visualization of the modes.

- 1 In the **Home** toolbar, click  **Add Plot Group** and choose **3D Plot Group**.
- 2 In the **Settings** window for **3D Plot Group**, type 3D Sector in the **Label** text field.
- 3 Locate the **Data** section. From the **Dataset** list, choose **Revolution 2D 3**.
- 4 From the **Parameter value (r_{res} (um), n_m , p)** list, choose **l: $r_{res}=10$ um, $n_m=80$, $p=1$** .

Multislice 1

- 1 In the **3D Sector** toolbar, click  **More Plots** and choose **Multislice**.
- 2 In the **Settings** window for **Multislice**, locate the **Multipane Data** section.
- 3 Find the **X-planes** subsection. In the **Planes** text field, type 0.
- 4 Find the **Y-planes** subsection. In the **Planes** text field, type 0.
- 5 Locate the **Coloring and Style** section. From the **Color table** list, choose **AuroraBorealis**.

Revolution 2D 3

- 1 In the **Model Builder** window, expand the **Results>Datasets** node, then click **Revolution 2D 3**.
- 2 In the **Settings** window for **Revolution 2D**, click to expand the **Revolution Layers** section.
- 3 From the **Number of layers** list, choose **Custom**.
- 4 In the **Layers** text field, type 100.
- 5 In the **Start angle** text field, type -105.
- 6 In the **Revolution angle** text field, type 15.

Arrow Volume 1

- 1 In the **Model Builder** window, right-click **3D Sector** and choose **Arrow Volume**.
- 2 In the **Settings** window for **Arrow Volume**, locate the **Expression** section.
- 3 In the **R component** text field, type $E_r \cdot \exp(-i \cdot n_m \cdot \text{rev}3\text{phi})$.
- 4 In the **PHI component** text field, type $E_{\text{phi}} \cdot \exp(-i \cdot n_m \cdot \text{rev}3\text{phi})$.
- 5 In the **Z component** text field, type $E_z \cdot \exp(-i \cdot n_m \cdot \text{rev}3\text{phi})$.
- 6 Locate the **Arrow Positioning** section. Find the **X grid points** subsection. In the **Points** text field, type 100.
- 7 Find the **Y grid points** subsection. In the **Points** text field, type 100.
- 8 Find the **Z grid points** subsection. In the **Points** text field, type 1.

Isosurface 1

- 1 Right-click **3D Sector** and choose **Isosurface**.
- 2 In the **Settings** window for **Isosurface**, locate the **Expression** section.
- 3 In the **Expression** text field, type $ewfd.E_{\text{phi}} \cdot \exp(-i \cdot n_m \cdot \text{rev}3\text{phi})$.
- 4 Locate the **Levels** section. From the **Entry method** list, choose **Levels**.
- 5 In the **Levels** text field, type $\text{range}(-12, 5, 12)$.
- 6 Locate the **Coloring and Style** section. From the **Color table** list, choose **WaveClassic**.
- 7 From the **Scale** list, choose **Linear symmetric**.

Transparency 1

- 1 Right-click **Isosurface 1** and choose **Transparency**.
- 2 In the **Settings** window for **Transparency**, locate the **Transparency** section.
- 3 In the **Transparency** text field, type 0.45.

4 In the **3D Sector** toolbar, click  **Plot**.

$r_{\text{res}}=10$, $n_{\text{m}}=80$, $p=1$, $l=3$ Eigenfrequency=327.08 THz Multislice: Electric field norm (V/m) Arrow Volume: Isosurface: $\text{ewfd.Ephi} \cdot \exp(-i * n_{\text{m}} * \text{rev}3\text{phi})$

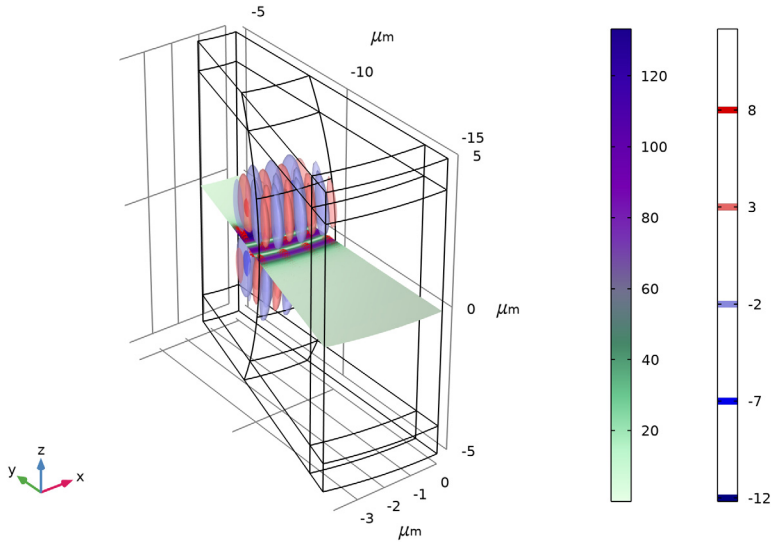

Quality Factor for Different Modes and Radii

- 1 In the **Model Builder** window, right-click **Mode Localization** and choose **Duplicate**.
- 2 In the **Settings** window for **ID Plot Group**, type Quality Factor for Different Modes and Radii in the **Label** text field.
- 3 Locate the **Data** section. From the **Dataset** list, choose **Parametric Sweep Eigenfrequency Study/Parametric Solutions 1 (sol5)**.
- 4 Locate the **Plot Settings** section. Clear the **Two y-axes** check box.
- 5 Locate the **Axis** section. Select the **y-axis log scale** check box.
- 6 Locate the **Legend** section. From the **Position** list, choose **Lower right**.

Global 1

Now, replace the ModeLoc expression with Q_{mat} , the material losses.

- 1 In the **Model Builder** window, expand the **Quality Factor for Different Modes and Radii** node, then click **Global 1**.
- 2 In the **Settings** window for **Global**, locate the **y-Axis Data** section.

3 In the table, enter the following settings:

Expression	Unit	Description
Q_mat	1	Material losses

4 Locate the **x-Axis Data** section. From the **Axis source data** list, choose **All solutions**.

5 In the **Expression** text field, type r_res.

6 Locate the **Coloring and Style** section. Find the **Line style** subsection. From the **Line** list, choose **Dashed**.

7 From the **Color** list, choose **Black**.

8 Find the **Line markers** subsection. From the **Marker** list, choose **None**.

Global 2

1 In the **Model Builder** window, click **Global 2**.

2 In the **Settings** window for **Global**, locate the **x-Axis Data** section.

3 From the **Axis source data** list, choose **All solutions**.

4 In the **Expression** text field, type r_res.

5 Locate the **Coloring and Style** section. Find the **Line style** subsection. From the **Line** list, choose **None**.

6 In the **Quality Factor for Different Modes and Radii** toolbar, click  **Plot**.

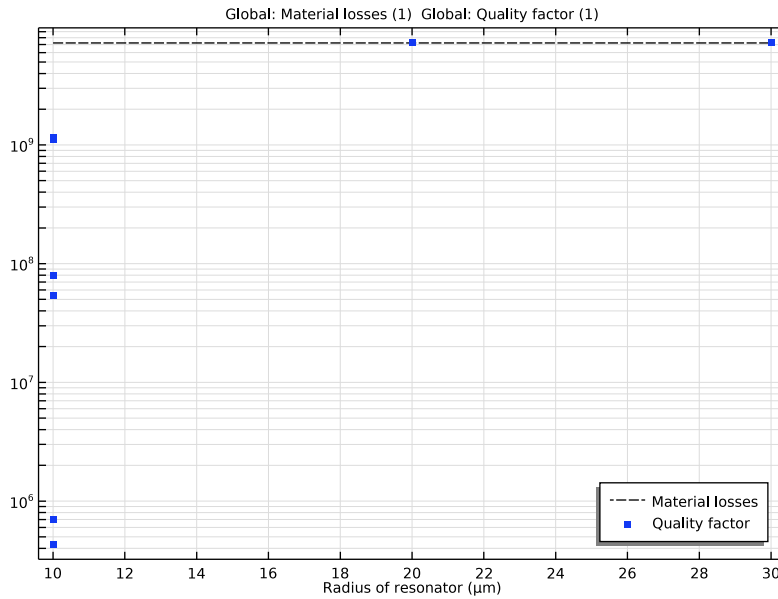

This plot demonstrates that for large resonator radii, the losses are limited by the material loss, whereas for small radii, radiation loss dominates.

Evaluation Group 1

Finally, add two evaluation groups to extract numerical values for the results.

In the **Results** toolbar, click  **Evaluation Group**.

Global Evaluation 1

1 Right-click **Evaluation Group 1** and choose **Global Evaluation**.

2 In the **Settings** window for **Global Evaluation**, locate the **Expressions** section.

3 In the table, enter the following settings:

Expression	Unit	Description
ewfd.lambda0	μm	Wavelength
ewfd.Qfactor	1	Quality factor
Q_mat	1	Material losses
ewfd.damp	kHz	Damping in time

Expression	Unit	Description
damp	kHz	Damping from material losses
$\text{ewfd.Qfactor} * \text{c_const} / (\text{ewfd.omega} * \text{n_res} * \text{r_res})$	1	Finesse

4 In the **Evaluation Group 1** toolbar, click  **Evaluate**.

Evaluation Group 2

1 In the **Results** toolbar, click  **Evaluation Group**.

2 In the **Settings** window for **Evaluation Group**, locate the **Data** section.

3 From the **Dataset** list, choose **Parametric Sweep Eigenfrequency Study/ Parametric Solutions 1 (sol5)**.

Global Evaluation 1

1 Right-click **Evaluation Group 2** and choose **Global Evaluation**.

2 In the **Settings** window for **Global Evaluation**, locate the **Expressions** section.

3 In the table, enter the following settings:

Expression	Unit	Description
f_res	THz	Resonance frequency
ewfd.Qfactor	1	Quality factor

4 In the **Evaluation Group 2** toolbar, click  **Evaluate**.