

Orbital Angular Momentum Beam

Introduction

It is well known that light has energy. The photon has an energy of $h\nu$, where h is the Planck constant and ν is the frequency. It is also known that the photon, even though it is a massless particle, possesses a linear momentum. That is, it exerts a force in its propagation direction. This knowledge has led to ideas of spacecraft propulsion based on the radiation pressure from sunlight hitting large mirrors — so called solar sails.

Light also possesses angular momentum in two different forms — spin angular momentum and orbital angular momentum (OAM). Spin angular momentum is associated with the light field polarization. For circular polarization, the electric and magnetic field vectors rotate as the wave propagates. Orbital angular momentum, on the other hand, is related to the wave's spatial field distribution and in particular the spiraling (helical) phase distribution. The discovery that light also possesses OAM is quite recent. The first paper was published as late as 1992 (see [Ref. 1](#)). An introduction to the field of OAM waves and its development since 1992 is found in [Ref. 2](#).

This phase distribution produces a Gaussian donut beam (c.f. [Figure 1](#)).

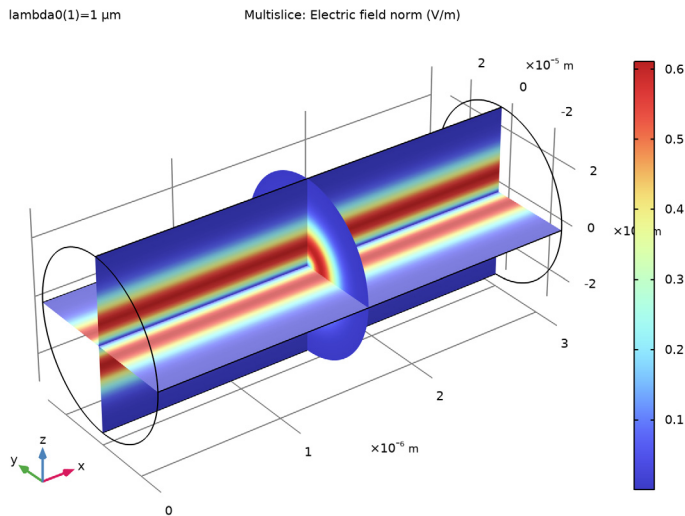

Figure 1: The electric field norm, showing the ring structure of the beam.

As shown in **Figure 2**, the phase rotates around the optical axis as the beam propagates.

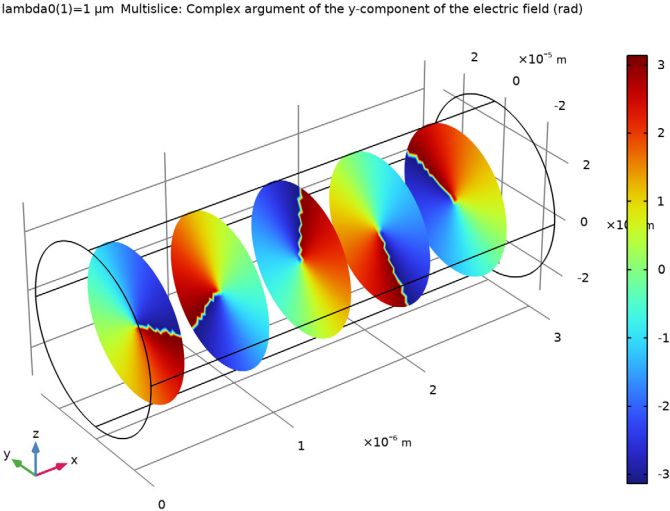

Figure 2: Phase distribution at five different locations along the direction of propagation. As shown, the phase twists as the beam propagates.

The resulting beam, also called a vortex beam or a helical beam, has a spiraling phase distribution as shown in [Figure 3](#) below.

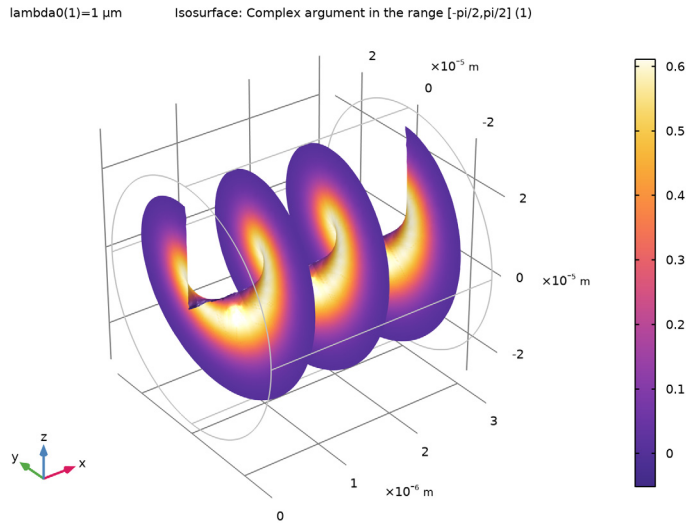

Figure 3: The spiraling phase variation of the vortex (OAM) beam.

One way of creating a beam with OAM is to send a Gaussian beam through a phase plate with a spiraling thickness. Thereby, the transmitted beam will get a spiraling phase front, resulting in a vortex beam.

Since vortex beams having different twists don't interfere with each other, the use of these waves for communication has become a very active research topic. For more information, see [Ref. 3](#).

Model Definition

This model simulates a Laguerre–Gaussian beam with the Electromagnetic Waves, Beam Envelopes interface, using the unidirectional wave formulation. The input beam is a focused Gaussian beam with a spiral phase distribution.

For a wave propagating in the x -direction and with a transverse radial coordinate r , the Laguerre–Gauss field distribution is given by

$$E_{m,n}(r, \phi, x) = E_0 \frac{w_0}{w(x)} e^{in\phi} \left(\frac{r\sqrt{2}}{w(x)} \right)^n L_m^n \left(\frac{2r^2}{w^2(x)} \right) \exp \left(-\frac{r^2}{w^2(x)} \right) \exp \left(-ikx - i\frac{kr^2}{2R(x)} + i\Psi_{m,n}(x) \right) \quad (1)$$

where the spot radius varies as the wave propagates as

$$w(x) = w_0 \sqrt{1 + \frac{x^2}{x_0^2}} \quad (2)$$

and the wave front curvature evolves as

$$R(x) = x \left(1 + \frac{x^2}{x_0^2} \right).$$

Here $x_0 = \pi n_0 w_0^2 / \lambda$ is the Rayleigh range, k is the wave number, L_m^n is a generalized Laguerre polynomial with radial mode number m and angular mode number n . The phase function is now

$$\Psi_{m,n}(x) = (n + 2m + 1) \arctan(x/x_0). \quad (3)$$

This model simulates a beam with radial mode number 0 and angular mode number 1. This beam will have one radial node, located on the optical axis. The generalized Laguerre polynomial for this mode is

$$L_0^1 = 1. \quad (4)$$

Comparing [Equation 1](#) with the field distribution for the lowest order Gaussian beam (for example see the Application Library model [Self-Focusing](#)), makes it possible to identify that

$$E_{0,1}(r, \phi, x) = E_0 e^{i\phi} \frac{r\sqrt{2}}{w(x)} \exp(i(\Psi_{0,1}(x) - \Psi_{0,0}(x))) E_{0,0}(r, x). \quad (5)$$

Thus, in the model, the expression

$$E_0 e^{i\phi} \frac{r\sqrt{2}}{w(x)} \exp(i(\Psi_{0,1}(x) - \Psi_{0,0}(x))) = E_0 e^{i\phi} \frac{r\sqrt{2}}{w(x)} \exp(i \arctan(x/x_0)) \quad (6)$$

will be used as the Gaussian beam input amplitude.

References

1. L. Allen and others, “Orbital angular momentum of light and the transformation of Laguerre-Gaussian laser modes,” *Physical Review A*, vol. 45, no. 11, pp. 8185–8189, 1992.
 2. S.M. Barnett, M. Babiker, and M.J. Padgett, “Optical orbital angular momentum,” *Philosophical Transactions of the Royal Society A*, vol. 375, <https://doi.org/10.1098/rsta.2015.0444>, 2017.
 3. A.E. Willner, “Twisted light could dramatically boost data rates,” *IEEE Spectrum*, vol. 53, no. 8, pp. 34–39, 2016.
-

Application Library path: Wave_Optics_Module/Beam_Propagation/orbital_angular_momentum



Modeling Instructions

From the **File** menu, choose **New**.

NEW

In the **New** window, click  **Model Wizard**.

MODEL WIZARD

- 1 In the **Model Wizard** window, click  **3D**.
- 2 In the **Select Physics** tree, select **Optics>Wave Optics>Electromagnetic Waves, Beam Envelopes (ewbe)**.
- 3 Click **Add**.
- 4 Click  **Study**.
- 5 In the **Select Study** tree, select **Preset Studies for Selected Physics Interfaces>Wavelength Domain**.
- 6 Click  **Done**.

GLOBAL DEFINITIONS

Parameters 1



- 1 In the **Model Builder** window, under **Global Definitions** click **Parameters 1**.

- 2 In the **Settings** window for **Parameters**, locate the **Parameters** section.
- 3 In the table, enter the following settings:

Name	Expression	Value	Description
lda0	1[um]	1E-6 m	Wavelength
w0	10*lda0	1E-5 m	Spot radius
zR	pi*w0^2/lda0	3.1416E-4 m	Rayleigh range
E0	1[V/m]	1 V/m	Electric field amplitude

GEOMETRY I

Cylinder 1 (cyl1)

- 1 In the **Geometry** toolbar, click  **Cylinder**.
- 2 In the **Settings** window for **Cylinder**, locate the **Size and Shape** section.
- 3 In the **Radius** text field, type $3*w_0$.
- 4 In the **Height** text field, type $3*lda_0$.
- 5 Locate the **Axis** section. From the **Axis type** list, choose **x-axis**.
- 6 Click  **Build All Objects**.

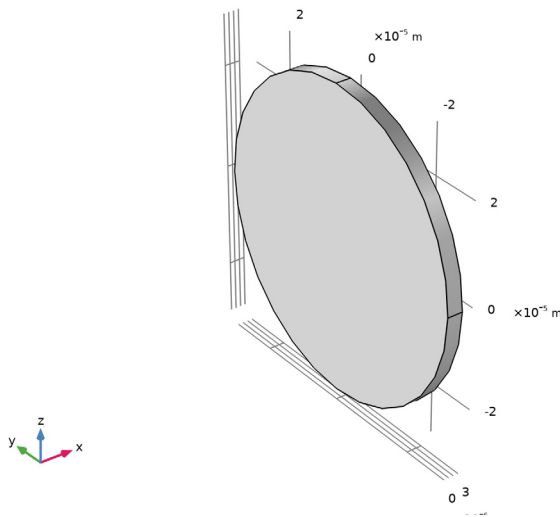



DEFINITIONS

This view is very compressed in the propagation direction. The following instructions change the Camera's View scale to make the domain expand in the x direction.

In the **Model Builder** window, expand the **Component 1 (comp1)>Definitions** node.

Camera

- 1 In the **Model Builder** window, expand the **Component 1 (comp1)>Definitions>View 1** node, then click **Camera**.
- 2 In the **Settings** window for **Camera**, locate the **Camera** section.
- 3 From the **View scale** list, choose **Manual**.
- 4 In the **x scale** text field, type 50.
- 5 Click  **Update**.
- 6 Click the  **Zoom Extents** button in the **Graphics** toolbar.

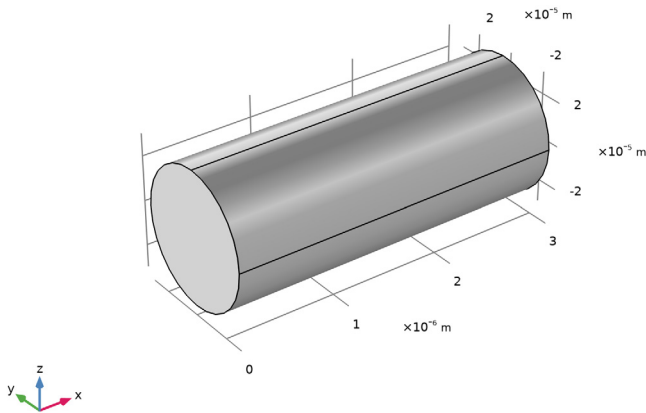

MATERIALS

Air

- 1 In the **Model Builder** window, under **Component 1 (comp1)** right-click **Materials** and choose **Blank Material**.
- 2 In the **Settings** window for **Material**, type **Air** in the **Label** text field.

3 Locate the **Material Contents** section. In the table, enter the following settings:

Property	Variable	Value	Unit	Property group
Refractive index, real part	n_{iso} ; $n_{ii} = n_{iso}$, $n_{ij} = 0$	1		Refractive index
Refractive index, imaginary part	$k_{i_{iso}}$; $k_{iii} =$ $k_{i_{iso}}$, $k_{ij} = 0$	0		Refractive index

DEFINITIONS

Now, add a function and some variables that will be used for defining the input beam.

Spot Radius

- 1 In the **Home** toolbar, click $f(\infty)$ **Functions** and choose **Local>Analytic**.
- 2 In the **Settings** window for **Analytic**, type Spot Radius in the **Label** text field.
- 3 In the **Function name** text field, type w .
- 4 Locate the **Definition** section. In the **Expression** text field, type $w0 * \sqrt{1 + (x/zR)^2}$.
- 5 Locate the **Units** section. In the table, enter the following settings:

Argument	Unit
x	m

- 6 In the **Function** text field, type m .

Beam Variables

- 1 In the **Model Builder** window, right-click **Definitions** and choose **Variables**.
- 2 In the **Settings** window for **Variables**, type Beam Variables in the **Label** text field.
- 3 Locate the **Variables** section. In the table, enter the following settings:

Name	Expression	Unit	Description
ρ	$\sqrt{y^2 + z^2}$	m	Transverse radial coordinate
ϕ	$\text{atan2}(y, z)$	rad	Transverse azimuthal coordinate
EGO	$E0 * \rho * \sqrt{2} / w(x) * \exp(j * \phi) * \exp(j * \text{atan}(x/zR))$	V/m	Gaussian beam amplitude

Plot Variables

The following instructions add two variables that later will be used for visualizing the field's spiraling phase.

- 1 Right-click **Definitions** and choose **Variables**.
- 2 In the **Settings** window for **Variables**, type `Plot Variables` in the **Label** text field.
- 3 Locate the **Variables** section. In the table, enter the following settings:

Name	Expression	Unit	Description
argEy	<code>arg(ewbe.Ey)</code>	rad	Complex argument of the y-component of the electric field
argWindow	<code>if(argEy<-pi/2,-2*pi, if(argEy>pi/2,2*pi, argEy))</code>		Complex argument in the range $[-\pi/2, \pi/2]$

ELECTROMAGNETIC WAVES, BEAM ENVELOPES (EWBE)

Set up the physics for unidirectional propagation. Also use the curl type 2 shape function. This makes the problem solve with slightly more degrees of freedom, but the phase plot becomes smoother.

- 1 In the **Model Builder** window, under **Component 1 (comp1)** click **Electromagnetic Waves, Beam Envelopes (ewbe)**.
- 2 In the **Settings** window for **Electromagnetic Waves, Beam Envelopes**, locate the **Wave Vectors** section.
- 3 From the **Number of directions** list, choose **Unidirectional**.
- 4 Click to expand the **Discretization** section. From the **Electric field envelopes** list, choose **Quadratic type 2**.

A Matched boundary condition launches a Gaussian beam, defined by the amplitude variable that was previously defined.

Matched Boundary Condition 1

- 1 In the **Physics** toolbar, click  **Boundaries** and choose **Matched Boundary Condition**.

2 Select Boundary 1 only.

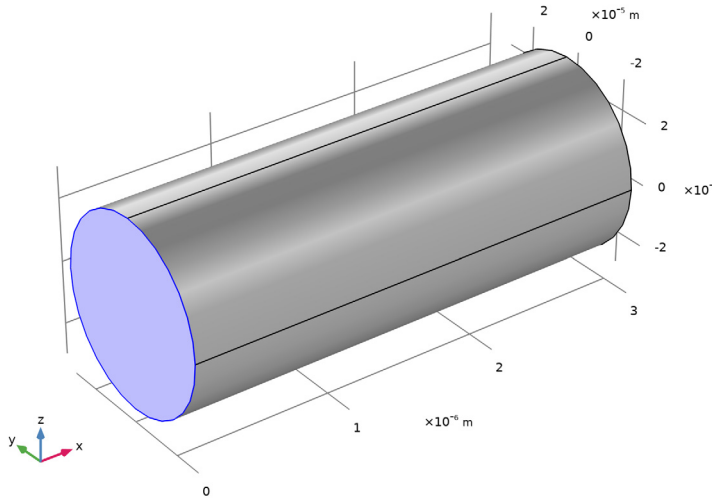

3 In the **Settings** window for **Matched Boundary Condition**, locate the **Matched Boundary Condition** section.

4 From the **Incident field** list, choose **Gaussian beam**.

5 In the w_0 text field, type w_0 .

6 Specify the \mathbf{E}_{g0} vector as

0	x
EGO	y
0	z

Matched Boundary Condition 2

1 In the **Physics** toolbar, click  **Boundaries** and choose **Matched Boundary Condition**.

2 Select Boundary 6 only.

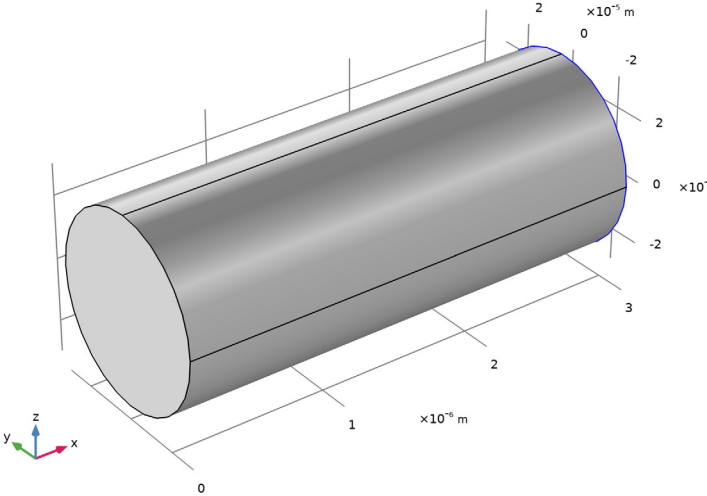

MESH 1

- 1 In the **Model Builder** window, under **Component 1 (comp1)** right-click **Mesh 1** and choose **Build All**.

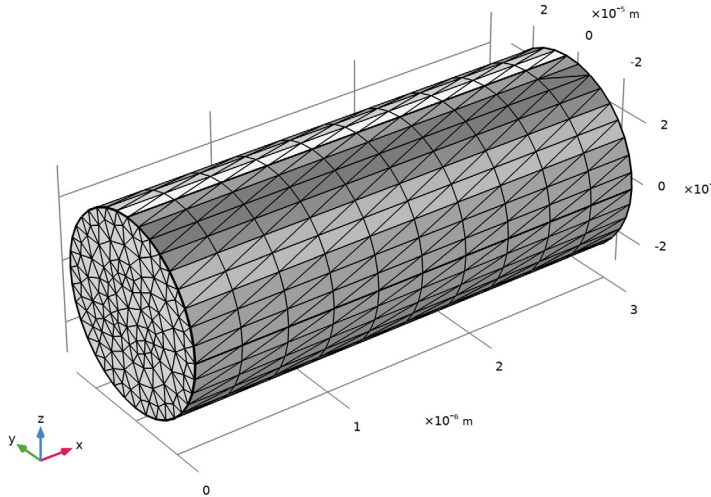

Notice that the curl type 2 shape function doesn't work with a structured mesh. Thus, the automatically generated swept mesh has automatically been converted to a tetrahedral (unstructured) mesh.

STUDY 1

Step 1: Wavelength Domain

- 1 In the **Model Builder** window, under **Study 1** click **Step 1: Wavelength Domain**.
- 2 In the **Settings** window for **Wavelength Domain**, locate the **Study Settings** section.
- 3 In the **Wavelengths** text field, type $1\text{da}0$.
- 4 In the **Home** toolbar, click **Compute**.

RESULTS

Electric Field (ewbe)

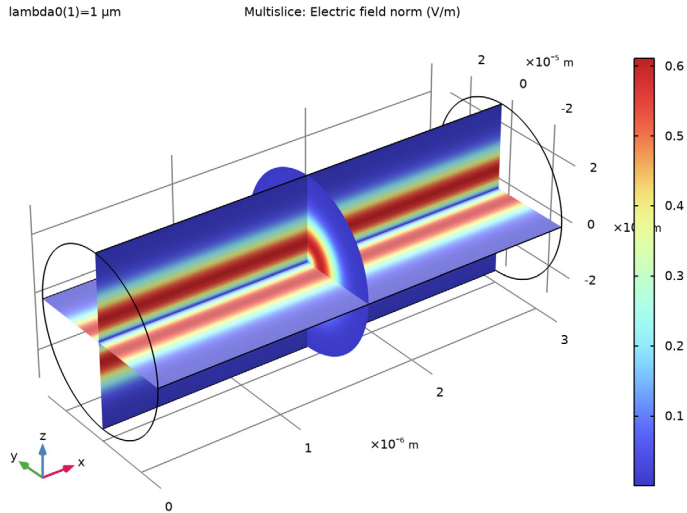

The plot shows that the beam has a ring structure, with no field on the propagation axis.

Multislice 2

To visualize the spiraling phase distribution, we add a Multislice plot.

- 1 In the **Electric Field (ewbe)** toolbar, click  **More Plots** and choose **Multislice**.
- 2 In the **Settings** window for **Multislice**, locate the **Expression** section.
- 3 In the **Expression** text field, type `argEy`.
- 4 Locate the **Multiplane Data** section. Find the **X-planes** subsection. In the **Planes** text field, type 5.
- 5 Find the **Y-planes** subsection. In the **Planes** text field, type 0.
- 6 Find the **Z-planes** subsection. In the **Planes** text field, type 0.

7 In the **Electric Field (ewbe)** toolbar, click  **Plot**.

lambda0(1)=1 μm Multislice: Electric field norm (V/m)
 Multislice: Complex argument of the y-component of the electric field (rad)

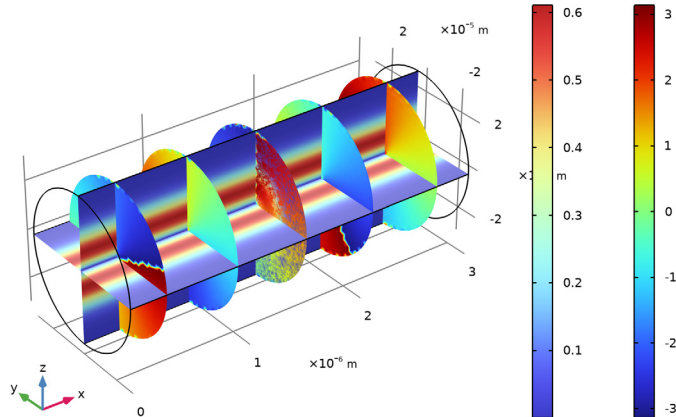

Inspecting the phase plot, it is clear that the phase becomes noisier in the parts of the beam where the intensity is low. A filter is added to remove the outermost parts of the beam, where the intensity is really low.

Filter 1

- 1 Right-click **Multislice 2** and choose **Filter**.
- 2 In the **Settings** window for **Filter**, locate the **Element Selection** section.
- 3 In the **Logical expression for inclusion** text field, type $\rho < 2.5 * w0$.

Electric Field

- 1 In the **Model Builder** window, under **Results>Electric Field (ewbe)** click **Electric Field**.
- 2 In the **Settings** window for **Multislice**, locate the **Multipane Data** section.
- 3 Find the **X-planes** subsection. In the **Planes** text field, type 0.

4 In the **Electric Field (ewbe)** toolbar, click  **Plot**.

lambda0(1)=1 μm Multislice: Electric field norm (V/m)
Multislice: Complex argument of the y-component of the electric field (rad)

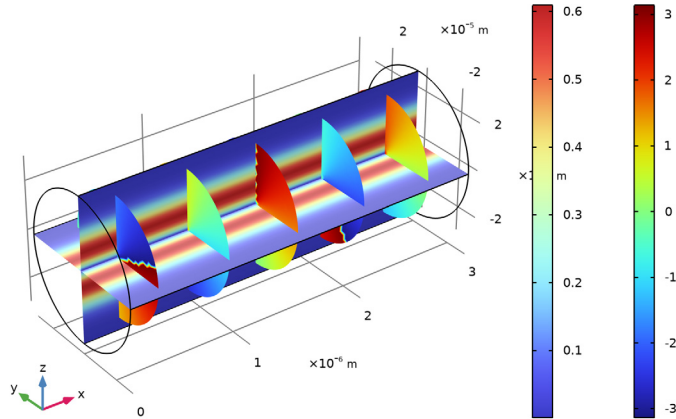

This phase plot looks clearer.

5 Right-click **Results>Electric Field (ewbe)>Electric Field** and choose **Disable**, to only display the phase plot.

Electric Field (ewbe)

1 In the **Model Builder** window, click **Electric Field (ewbe)**.

2 In the **Electric Field (ewbe)** toolbar, click  **Plot**.

3 Click the  **Zoom Extents** button in the **Graphics** toolbar.

lambda0(1)=1 μm Multislice: Complex argument of the y-component of the electric field (rad)

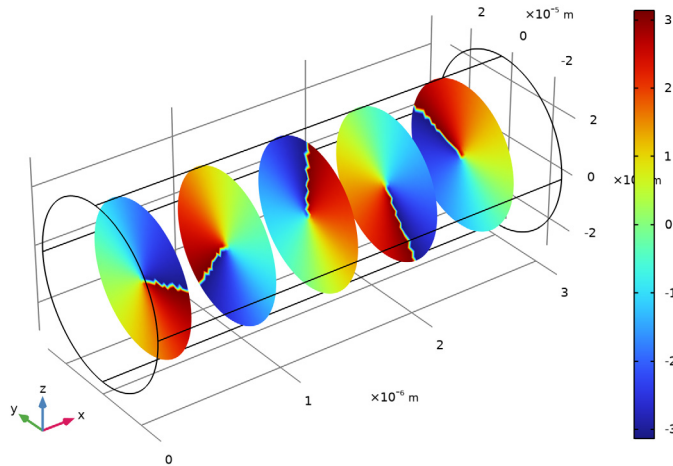

Phase Plot

The following instructions generate a plot of the spiraling phase.

- 1 In the **Home** toolbar, click  **Add Plot Group** and choose **3D Plot Group**.
- 2 In the **Settings** window for **3D Plot Group**, type Phase Plot in the **Label** text field.
- 3 Locate the **Plot Settings** section. From the **Color** list, choose **Gray**.

Isosurface 1

- 1 Right-click **Phase Plot** and choose **Isosurface**.
- 2 In the **Settings** window for **Isosurface**, locate the **Expression** section.
- 3 In the **Expression** text field, type \argWindow , which is the phase variable we previously defined.
- 4 Locate the **Levels** section. In the **Total levels** text field, type 1, to display just one isosurface.
- 5 Click to expand the **Quality** section. From the **Resolution** list, choose **Finer**.
- 6 Clear the **Use derivatives** check box, to give a smoother plot.

Filter 1

Finally, add the same filter as in the previous plot, but additionally include a term filtering out only the parts of the beam where $|\arg(E_y)|$ is less than $\pi/2$. This produces a nice looking "corkscrew" phase distribution.

- 1 Right-click **Isosurface 1** and choose **Filter**.
- 2 In the **Settings** window for **Filter**, locate the **Element Selection** section.
- 3 In the **Logical expression for inclusion** text field, type $\rho < 2.5 \cdot w_0 \cdot \text{abs}(\arg(ewbe \cdot Ey)) < \pi/2$.

Color Expression 1

- 1 In the **Model Builder** window, right-click **Isosurface 1** and choose **Color Expression**.
- 2 In the **Settings** window for **Color Expression**, locate the **Expression** section.
- 3 In the **Expression** text field, type $ewbe \cdot Ey$.
- 4 Locate the **Coloring and Style** section. From the **Color table** list, choose **HeatCameraLight**.
- 5 In the **Phase Plot** toolbar, click  **Plot**.

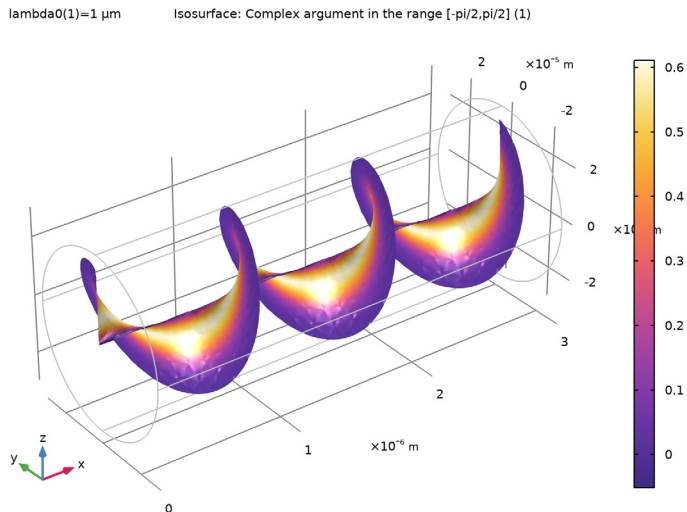

This plot looks too expanded in the x direction. This is handled by adding a new view for this plot group.

First make sure that the Views node is available under the Results node.

- 6 Click the  **Show More Options** button in the **Model Builder** toolbar.
- 7 In the **Show More Options** dialog box, select **Results>Views** in the tree.
- 8 In the tree, select the check box for the node **Results>Views**.
- 9 Click **OK**.



View 3D 2

In the **Model Builder** window, under **Results** right-click **Views** and choose **View 3D**.

Camera

- 1 In the **Model Builder** window, expand the **View 3D 2** node, then click **Camera**.
- 2 In the **Settings** window for **Camera**, locate the **Camera** section.
- 3 From the **View scale** list, choose **Automatic**.
- 4 Click  **Update**.

Phase Plot

- 1 In the **Model Builder** window, under **Results** click **Phase Plot**.
- 2 In the **Settings** window for **3D Plot Group**, locate the **Plot Settings** section.
- 3 From the **View** list, choose **View 3D 2**.
- 4 In the **Phase Plot** toolbar, click  **Plot**.
- 5 Click the  **Zoom Extents** button in the **Graphics** toolbar.

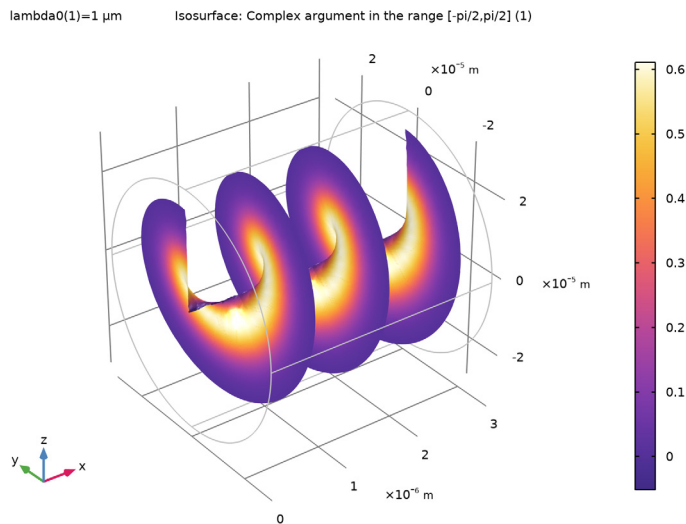

The plot has now better proportions. The next section improves it further by showing the y component of the electric field on the cylinder internal surface.

Surface 1

- 1 Right-click **Phase Plot** and choose **Surface**.
- 2 In the **Settings** window for **Surface**, locate the **Expression** section.

- 3 In the **Expression** text field, type `ewbe.Ey`.
- 4 Click to expand the **Title** section. From the **Title type** list, choose **None**.
- 5 Locate the **Coloring and Style** section. From the **Color table** list, choose **Cividis**.
- 6 Clear the **Color legend** check box.



Selection 1

- 1 Right-click **Surface 1** and choose **Selection**.
- 2 In the **Settings** window for **Selection**, locate the **Selection** section.
- 3 Click  **Paste Selection**.
- 4 In the **Paste Selection** dialog box, type 2 4 5 in the **Selection** text field.
- 5 Click **OK**.

Surface 2

In the **Model Builder** window, under **Results>Phase Plot** right-click **Surface 1** and choose **Duplicate**.

Selection 1

- 1 In the **Model Builder** window, expand the **Surface 2** node, then click **Selection 1**.
- 2 In the **Settings** window for **Selection**, locate the **Selection** section.
- 3 Click to select the **Activate Selection** toggle button.
- 4 Click  **Clear Selection**.
- 5 Click  **Paste Selection**.
- 6 In the **Paste Selection** dialog box, type 6 in the **Selection** text field.
- 7 Click **OK**.

8 In the **Phase Plot** toolbar, click  **Plot**.

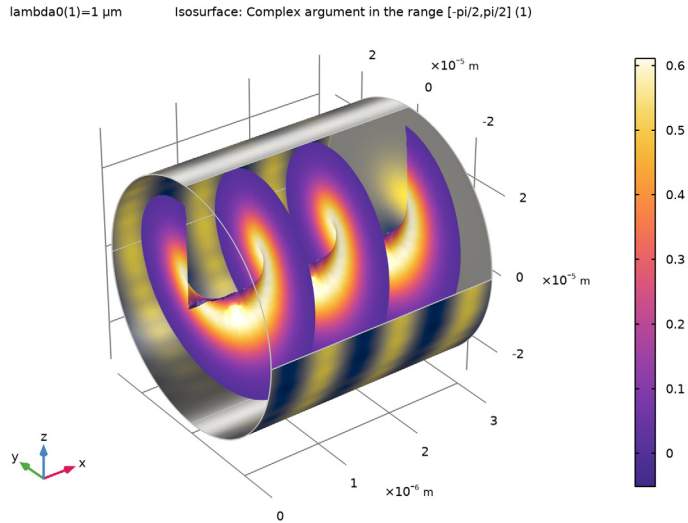

Animation 1

The instructions below show how to create an animation of the phase plot.

- 1 In the **Phase Plot** toolbar, click  **Animation** and choose **Player**.
- 2 In the **Settings** window for **Animation**, locate the **Animation Editing** section.
- 3 From the **Sequence type** list, choose **Dynamic data extension**.
- 4 Locate the **Playing** section. From the **Repeat** list, choose **Forever**.

Clicking the **Play** button in the toolbar for the Graphics window starts the animation.

Click the adjacent **Stop** button to end the animation.