



Bracket — Thermal-Stress Analysis

Introduction

The various examples based on a bracket geometry form a suite of tutorials which summarizes the fundamentals when modeling structural mechanics problems in COMSOL Multiphysics and the Structural Mechanics Module.

In this example you learn how to perform a thermal stress analysis.

Model Definition

The model used in this guide is an assembly of a bracket and its mounting bolts, which are all made of steel. This type of bracket can be used to install an actuator that is mounted on a pin placed between the two holes in the bracket arms. The geometry is shown in [Figure 1](#).

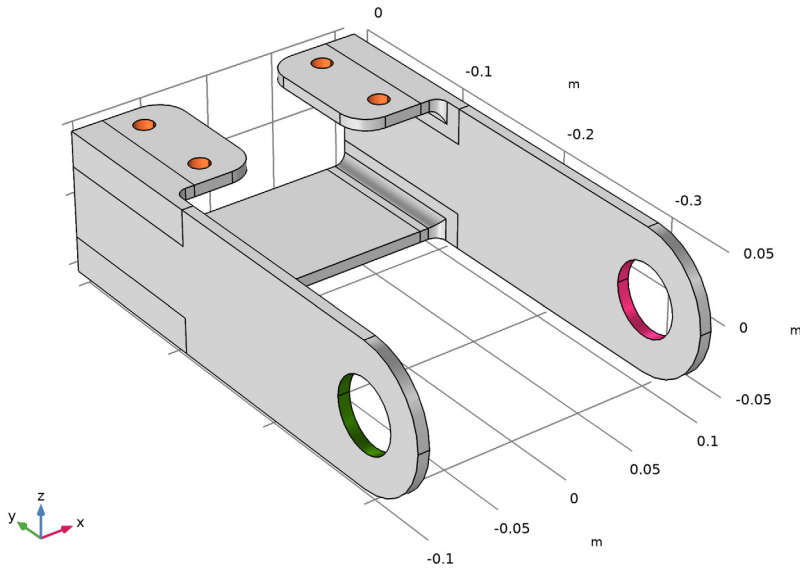

In this example, a temperature distribution is computed in the bracket and the resulting thermal stresses are determined. A heat flux of 10000 W/m^2 is applied on the lower side of the bolted plates. On all other boundaries, a convection boundary condition is used. The heat transfer coefficient is $10 \text{ W/m}^2\text{K}$ and room temperature (293.15 K) is used as external temperature.

The four bolts and the

Results

Figure 1 shows the temperature distribution in the bracket as well as arrows indicating the prescribed influx of heat. The temperature is highest where the inward heat flux is prescribed, and decreases as heat is removed by convection from all other boundaries.

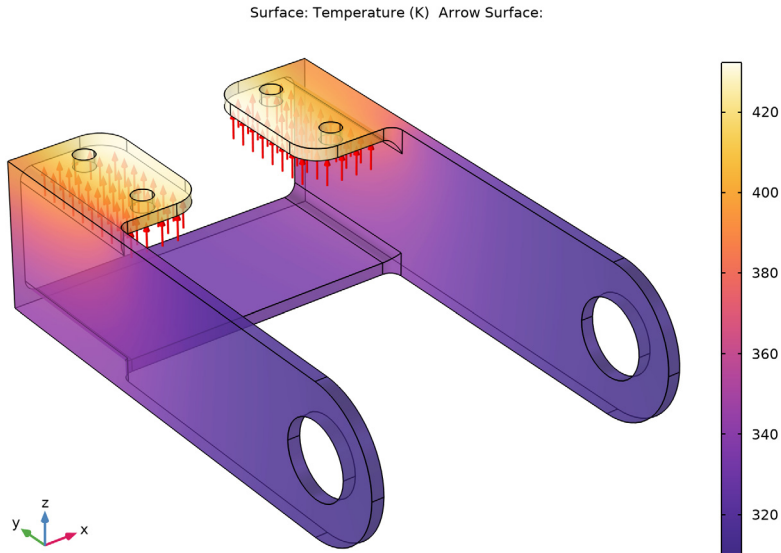

Figure 1: Temperature distribution in the bracket. The prescribed heat flux is indicated by arrows.

Figure 2 shows the von Mises stress distribution in the bracket. You can see how the bracket is deformed by the thermal expansion. Due to the boundary conditions and the non-uniform temperature distribution, thermal stresses develop in the structure.

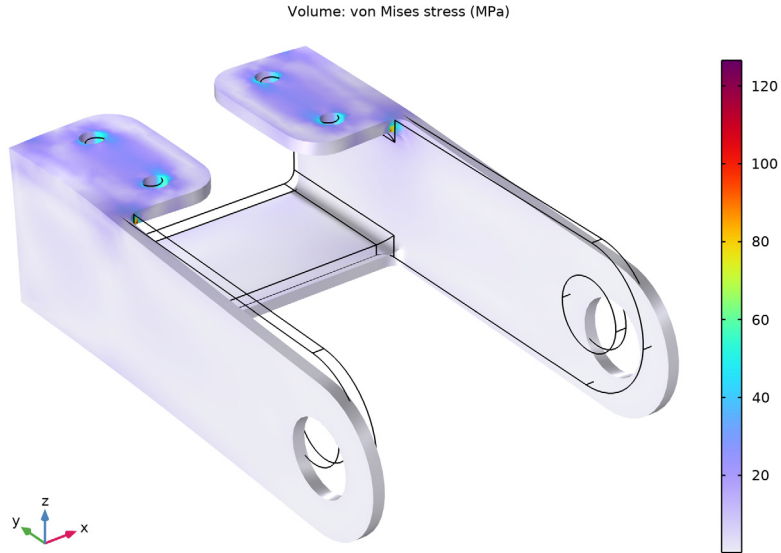

Figure 2: Von Mises stress distribution in the bracket.

Notes About the COMSOL Implementation

COMSOL Multiphysics contains physics interfaces for structural analysis as well as thermal analysis. You can set up the coupled analysis for thermal-structure interaction using three different methods:

- Add a **Thermal Stress, Solid** interface as in this example. The coupling is predefined and appears in the **Thermal Expansion** nodes under **Multiphysics**. This is the easiest approach.
- Add separate **Solid Mechanics** and **Heat Transfer in Solids** interfaces. Then add a **Thermal Expansion** node under **Multiphysics**, and check the settings in them.
- Add separate **Solid Mechanics** and **Heat Transfer in Solids** interfaces. Add a **Thermal Expansion** subnode under **Linear Elastic Material**, and do the appropriate settings there.

Application Library path: Structural_Mechanics_Module/Tutorials/
bracket_thermal



Modeling Instructions

From the **File** menu, choose **New**.

NEW

In the **New** window, click  **Model Wizard**.





MODEL WIZARD

- 1 In the **Model Wizard** window, click  **3D**.
- 2 In the **Select Physics** tree, select **Structural Mechanics>Thermal-Structure Interaction>Thermal Stress, Solid**.
- 3 Click **Add**.
- 4 Click  **Study**.
- 5 In the **Select Study** tree, select **General Studies>Stationary**.
- 6 Click  **Done**.

GEOMETRY I

The Thermal Stress, Solid interface is a multiphysics interface that combines a Solid Mechanics interface with a Heat Transfer in Solids interface. You can see the coupling between the physics interfaces under the **Multiphysics** node.

Import I (imp1)

- 1 In the **Home** toolbar, click  **Import**.
- 2 In the **Settings** window for **Import**, locate the **Import** section.
- 3 From the **Source** list, choose **COMSOL Multiphysics file**.
- 4 Click  **Browse**.
- 5 Browse to the model's Application Libraries folder and double-click the file `bracket.mphbin`.
- 6 Click  **Import**.
- 7 Click the  **Zoom Extents** button in the **Graphics** toolbar.

Form Union (fin)

- 1 In the **Model Builder** window, click **Form Union (fin)**.
- 2 In the **Settings** window for **Form Union/Assembly**, click  **Build Selected**.

ADD MATERIAL

- 1 In the **Home** toolbar, click  **Add Material** to open the **Add Material** window.

- 2 Go to the **Add Material** window.
- 3 In the tree, select **Built-in>Structural steel**.
- 4 Click **Add to Component** in the window toolbar.
- 5 In the **Home** toolbar, click  **Add Material** to close the **Add Material** window.

SOLID MECHANICS (SOLID)

Now specify the boundary conditions for the Solid Mechanics interface.

Roller 1

- 1 In the **Model Builder** window, under **Component 1 (comp1)** right-click **Solid Mechanics (solid)** and choose **Roller**.
- 2 Select Boundaries 17 and 27 only.

Spring Foundation 1

- 1 In the **Physics** toolbar, click  **Boundaries** and choose **Spring Foundation**.
- 2 Select Boundaries 18–21 and 31–34 only.
- 3 In the **Settings** window for **Spring Foundation**, locate the **Spring** section.
- 4 From the **Spring type** list, choose **Total spring constant**.
- 5 From the list, choose **Diagonal**.
- 6 In the k_{tot} table, enter the following settings:

600 [kN/mm]	0	0
0	600 [kN/mm]	0
0	0	0

HEAT TRANSFER IN SOLIDS (HT)

In the **Model Builder** window, under **Component 1 (comp1)** click **Heat Transfer in Solids (ht)**.

Heat Flux 1

- 1 In the **Physics** toolbar, click  **Boundaries** and choose **Heat Flux**.
- 2 From the Selection list, choose **All boundaries**. Then remove boundaries 17 and 27.
- 3 In the **Settings** window for **Heat Flux**, locate the **Heat Flux** section.
- 4 From the **Flux type** list, choose **Convective heat flux**.
- 5 In the h text field, type 10.

Heat Flux 2

- 1 In the **Physics** toolbar, click  **Boundaries** and choose **Heat Flux**.

- 2 Select Boundaries 17 and 27 only.
- 3 In the **Settings** window for **Heat Flux**, locate the **Heat Flux** section.
- 4 In the q_0 text field, type $1e4$.

STUDY 1





In the **Home** toolbar, click  **Compute**.

RESULTS

Stress (solid)

Under the Results node, three plot groups are automatically added to show the default results for the structural and thermal analyses. The first plot group, **Stress (solid)**, shows the von Mises stresses on a scaled deformed geometry, as shown in [Figure 2](#).

Volume 1

- 1 In the **Model Builder** window, expand the **Stress (solid)** node, then click **Volume 1**.
- 2 In the **Settings** window for **Volume**, locate the **Expression** section.
- 3 From the **Unit** list, choose **MPa**.
- 4 In the **Stress (solid)** toolbar, click  **Plot**.
- 5 Click the  **Show Grid** button in the **Graphics** toolbar.
- 6 Click the  **Zoom Extents** button in the **Graphics** toolbar.
- 7 In the **Stress (solid)** toolbar, click  **Plot**.

Temperature (ht)

The second plot group, **Temperature (ht)**, displays the temperature distribution. Add some arrows indicating the thermal loading.

Arrow Surface 1

- 1 In the **Model Builder** window, right-click **Temperature (ht)** and choose **Arrow Surface**.
- 2 In the **Settings** window for **Arrow Surface**, locate the **Expression** section.
- 3 In the **X component** text field, type 0.
- 4 In the **Y component** text field, type 0.
- 5 In the **Z component** text field, type 1.
- 6 Locate the **Coloring and Style** section. From the **Arrow base** list, choose **Head**.

Selection 1

- 1 Right-click **Arrow Surface 1** and choose **Selection**.
- 2 Select Boundaries 17 and 27 only.

Arrow Surface 1

- 1 In the **Model Builder** window, click **Arrow Surface 1**.
- 2 In the **Settings** window for **Arrow Surface**, locate the **Arrow Positioning** section.
- 3 In the **Number of arrows** text field, type 100.
- 4 Locate the **Coloring and Style** section. Select the **Scale factor** check box.
- 5 In the associated text field, type 0.02.

Transparency 1

- 1 In the **Model Builder** window, right-click **Surface** and choose **Transparency**.
- 2 In the **Settings** window for **Transparency**, locate the **Transparency** section.
- 3 Set the **Transparency** value to **0.4**.
- 4 Set the **Fresnel transmittance** value to **0.4**.
- 5 In the **Temperature (ht)** toolbar, click  **Plot**.