



Bracket — Eigenfrequency Analysis

Introduction

In this example you learn how to perform an eigenfrequency analysis for both an unloaded structure and a prestressed structure.

When the structure is subjected to a constant external load, the stiffness generated by the stress may affect the natural frequencies of the structure. Tensile stresses tend to increase the natural frequencies, while compressive stresses tend to decrease them.

It is recommended you review the *Introduction to the Structural Mechanics Module*, which includes background information and discusses the `bracket_basic.mph` model relevant to this example.

Model Definition

This tutorial is an extension of the example described in the section “The Fundamentals: A Static Linear Analysis” in the *Introduction to the Structural Mechanics Module*.

The model geometry is represented in [Figure 1](#).

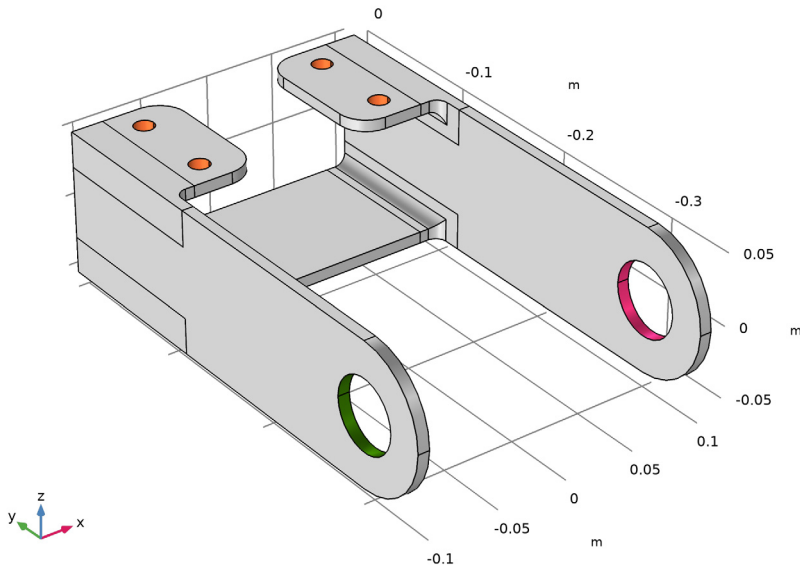

Figure 1: Geometry of the bracket.

In the first case, the natural frequency of the unloaded bracket is studied, while in the second case it is considered how the natural frequencies are affected by a static external load applied at the bracket holes. The left arm is under a pure tensile load while the right arm is under a pure compressive load.

Results and Discussion

Figure 2 and Figure 3 show the first six eigenmodes for both the unloaded and the prestressed case, respectively. The difference in the two first mode shapes between the two load cases is significant.

The two first mode shapes correspond to the bending mode in the x direction in the bracket arms. For the unloaded case these are expected to be approximately equal because of the symmetry. For the prestressed case, however, there will be a difference because of stress stiffening (left arm) and stress softening (right arm).

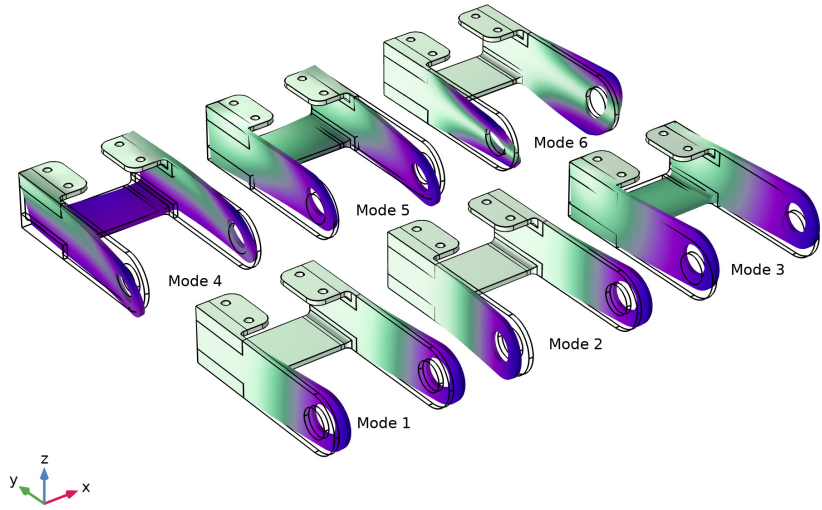

Figure 2: Six first eigenmode shapes for the unloaded case.

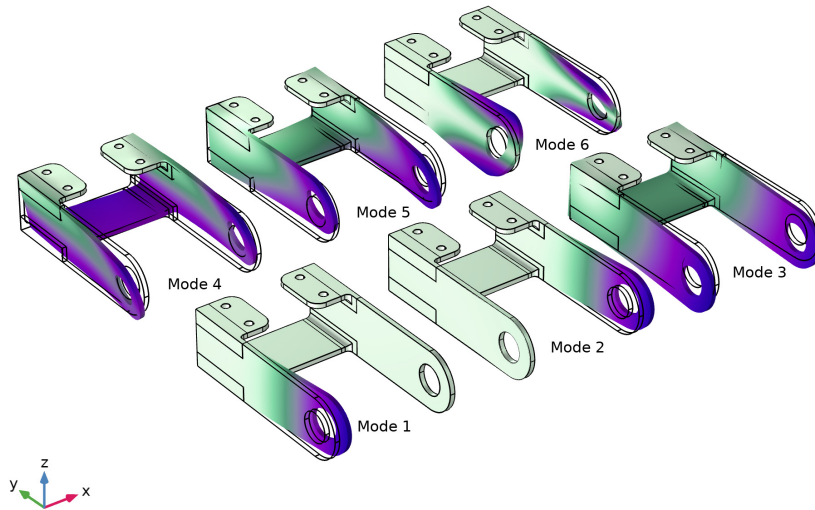

Figure 3: Six first eigenmode shapes for the prestressed case.

When comparing eigenmodes, it should be noted that the modes may be computed with reversed signs. This can even happen when the same study is run twice.

In [Figure 4](#), the stress state from the static preload is shown.

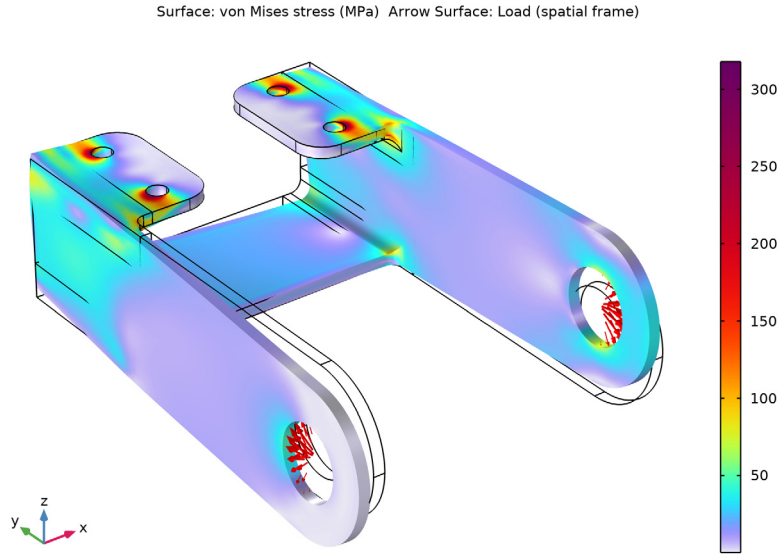

Figure 4: Equivalent stress from the preload. Note the nonlinear color scale.

In Figure 5 below, the frequency shift in the two first eigenmodes is clearly visible.

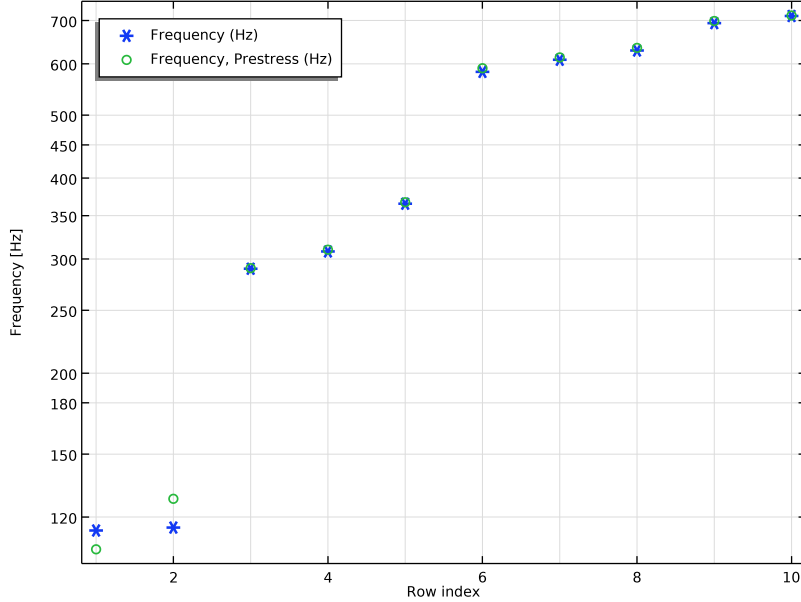

Figure 5: Six first eigenfrequencies for the unloaded case (stars) and the prestressed case (circles).

For the unloaded case, the two first eigenfrequencies are 115 Hz and correspond to the bending mode in the x direction for the two bracket arms. For the prestressed load case, the eigenfrequencies for the bending modes are 107 Hz for one of the arms and 128 Hz for the other. Such a frequency shift is expected since a tensile load causes stress stiffening, while a compressive load causes stress softening. The other mode shapes are not significantly affected by the prestress.

Notes About the COMSOL Implementation

For a structural mechanics physics interface in COMSOL Multiphysics, there are two predefined study types available for eigenfrequency analysis: **Eigenfrequency** and **Prestressed Analysis, Eigenfrequency**.

The plain eigenfrequency analysis computes the natural frequencies of the unloaded structure. The contribution of any load boundary condition is disregarded and the **Prescribed displacement** constraints are considered as having the value zero.

In the prestressed eigenfrequency analysis, a stationary analysis is first performed to take into account the different loads and nonzero displacement constraints. The resulting stress is then automatically taken into account in the stiffness used in the eigenfrequency calculation.



Application Library path: Structural_Mechanics_Module/Tutorials/
bracket_eigenfrequency

Modeling Instructions

APPLICATION LIBRARIES

- 1 From the **File** menu, choose **Application Libraries**.
- 2 In the **Application Libraries** window, select **Structural Mechanics Module>Tutorials>bracket_basic** in the tree.
- 3 Click  **Open**.

ADD STUDY

- 1 In the **Home** toolbar, click  **Add Study** to open the **Add Study** window.
- 2 Go to the **Add Study** window.
- 3 Find the **Studies** subsection. In the **Select Study** tree, select **General Studies>Eigenfrequency**.
- 4 Click **Add Study** in the window toolbar.
- 5 In the **Home** toolbar, click  **Add Study** to close the **Add Study** window.

STUDY 1

Step 1: Eigenfrequency

In the **Eigenfrequency** study node you have the possibility to select the number of eigenfrequencies to compute, and the frequency around which you would like to search for these frequencies. By default, the eigenvalue solver finds the six lowest frequencies.

- 1 In the **Settings** window for **Eigenfrequency**, locate the **Study Settings** section.
- 2 Select the **Desired number of eigenfrequencies** check box.
- 3 In the associated text field, type 10.
- 4 In the **Home** toolbar, click  **Compute**.

You can access the different eigenfrequency solutions in the 3D Plot Group Settings.

Note that the displacement values are normalized and have no physical significance. The normalization method can be changed in the **Eigenvalue Solver** node, located under the **Solver Configuration** node.

Modify the plot so that the first six eigenmodes are plotted side by side.

RESULTS

Mode Shapes, Original

- 1 In the **Settings** window for **3D Plot Group**, type *Mode Shapes, Original* in the **Label** text field.
- 2 Click to expand the **Title** section. From the **Title type** list, choose **None**.
- 3 Click to expand the **Plot Array** section. Select the **Enable** check box.
- 4 From the **Array shape** list, choose **Square**.
- 5 In the **Relative row padding** text field, type 0.4.
- 6 In the **Relative column padding** text field, type 0.4.

Surface 2

- 1 In the **Model Builder** window, expand the **Mode Shapes, Original** node.
- 2 Right-click **Results>Mode Shapes, Original>Surface 1** and choose **Duplicate**.
- 3 In the **Settings** window for **Surface**, locate the **Data** section.
- 4 From the **Dataset** list, choose **Study 1/Solution 1 (sol1)**.
- 5 From the **Eigenfrequency (Hz)** list, choose **115.58**.

Surface 3

- 1 Right-click **Surface 2** and choose **Duplicate**.
- 2 In the **Settings** window for **Surface**, locate the **Data** section.
- 3 From the **Eigenfrequency (Hz)** list, choose **289.84**.

Surface 4



- 1 Right-click **Surface 3** and choose **Duplicate**.
- 2 In the **Settings** window for **Surface**, locate the **Data** section.
- 3 From the **Eigenfrequency (Hz)** list, choose **308.17**.

Surface 5

- 1 Right-click **Surface 4** and choose **Duplicate**.
- 2 In the **Settings** window for **Surface**, locate the **Data** section.

- 3 From the **Eigenfrequency (Hz)** list, choose **365.14**.

Surface 6

- 1 Right-click **Surface 5** and choose **Duplicate**.
- 2 In the **Settings** window for **Surface**, locate the **Data** section.
- 3 From the **Eigenfrequency (Hz)** list, choose **583.22**.
- 4 Click the  **Zoom Extents** button in the **Graphics** toolbar.
- 5 Click the  **Show Grid** button in the **Graphics** toolbar.

Parameters

- 1 In the **Results** toolbar, click **P_i Parameters**.
- 2 In the **Settings** window for **Parameters**, locate the **Parameters** section.
- 3 In the table, enter the following settings:

| Name | Expression | Value | Description |
|------|------------|-------|----------------------|
| dx | -0.05 | -0.05 | Annotation offset, X |
| dy | -0.3 | -0.3 | Annotation offset, Y |

Annotation 1

- 1 In the **Model Builder** window, right-click **Mode Shapes, Original** and choose **Annotation**.
- 2 In the **Settings** window for **Annotation**, locate the **Annotation** section.
- 3 In the **Text** text field, type Mode 1.
- 4 Locate the **Position** section. In the **X** text field, type dx.
- 5 In the **Y** text field, type dy.
- 6 Locate the **Coloring and Style** section. Clear the **Show point** check box.
- 7 Click to expand the **Plot Array** section. Select the **Manual indexing** check box.

Annotation 2

- 1 Right-click **Annotation 1** and choose **Duplicate**.
- 2 In the **Settings** window for **Annotation**, locate the **Annotation** section.
- 3 In the **Text** text field, type Mode 2.
- 4 Locate the **Plot Array** section. In the **Column index** text field, type 1.

Annotation 3

- 1 Right-click **Annotation 2** and choose **Duplicate**.
- 2 In the **Settings** window for **Annotation**, locate the **Annotation** section.
- 3 In the **Text** text field, type Mode 3.

4 Locate the **Plot Array** section. In the **Column index** text field, type 2.

Annotation 4

- 1 Right-click **Annotation 3** and choose **Duplicate**.
- 2 In the **Settings** window for **Annotation**, locate the **Annotation** section.
- 3 In the **Text** text field, type Mode 4.
- 4 Locate the **Plot Array** section. In the **Row index** text field, type 1.
- 5 In the **Column index** text field, type 0.

Annotation 5

- 1 Right-click **Annotation 4** and choose **Duplicate**.
- 2 In the **Settings** window for **Annotation**, locate the **Annotation** section.
- 3 In the **Text** text field, type Mode 5.
- 4 Locate the **Plot Array** section. In the **Column index** text field, type 1.

Annotation 6

- 1 Right-click **Annotation 5** and choose **Duplicate**.
- 2 In the **Settings** window for **Annotation**, locate the **Annotation** section.
- 3 In the **Text** text field, type Mode 6.
- 4 Locate the **Plot Array** section. In the **Column index** text field, type 2.
- 5 In the **Mode Shapes, Original** toolbar, click  **Plot**.

Global Evaluation 1

- 1 In the **Results** toolbar, click  **Global Evaluation**.
- 2 In the **Settings** window for **Global Evaluation**, locate the **Expressions** section.
- 3 In the table, enter the following settings:

| Expression | Unit | Description |
|------------|------|-------------|
| freq | Hz | Frequency |

- 4 Click  **Evaluate**.

GLOBAL DEFINITIONS

Parameters 1

- 1 In the **Model Builder** window, under **Global Definitions** click **Parameters 1**.
- 2 In the **Settings** window for **Parameters**, locate the **Parameters** section.

3 In the table, enter the following settings:

| Name | Expression | Value | Description |
|------|------------|--------|-----------------------------|
| P0 | 30[MPa] | 3E7 Pa | Peak load intensity |
| YC | -300[mm] | -0.3 m | Y coordinate of hole center |

DEFINITIONS

Analytic 1 (an1)

- 1 In the **Home** toolbar, click  **Functions** and choose **Local>Analytic**.
- 2 In the **Settings** window for **Analytic**, type load in the **Function name** text field.
- 3 Locate the **Definition** section. In the **Expression** text field, type $F \cdot \cos(\text{atan2}(py, \text{abs}(px)))$.
- 4 In the **Arguments** text field, type F, py, px.
- 5 Locate the **Units** section. In the table, enter the following settings:

| Argument | Unit |
|----------|------|
| F | Pa |
| py | m |
| px | m |

- 6 In the **Function** text field, type Pa.

Boundary System 1 (sys1)

The default boundary coordinate system will have axes that change orientation with the deformation. As an effect, the applied load would be interpreted as a follower load. In this case, the load is intended to have fixed directions.

- 1 In the **Model Builder** window, click **Boundary System 1 (sys1)**.
- 2 In the **Settings** window for **Boundary System**, locate the **Settings** section.
- 3 From the **Frame** list, choose **Reference configuration**.

SOLID MECHANICS (SOLID)

Boundary Load 1

- 1 In the **Model Builder** window, under **Component 1 (comp1)** right-click **Solid Mechanics (solid)** and choose **Boundary Load**.
Apply a boundary load to the bracket holes.
- 2 In the **Settings** window for **Boundary Load**, locate the **Boundary Selection** section.

- 3 From the **Selection** list, choose **Pin Holes**.
- 4 Locate the **Coordinate System Selection** section. From the **Coordinate system** list, choose **Boundary System I (sys1)**.
- 5 Locate the **Force** section. Specify the \mathbf{F}_A vector as

| | |
|-------------------------------------|----|
| 0 | t1 |
| 0 | t2 |
| load(-P0,Z,Y-YC)*(sign(X)*(Y-YC)<0) | n |

ADD STUDY

- 1 In the **Home** toolbar, click  **Add Study** to open the **Add Study** window.
- 2 Go to the **Add Study** window.

The prestressed eigenfrequency analysis is available as a predefined study.
- 3 Find the **Studies** subsection. In the **Select Study** tree, select **Preset Studies for Selected Physics Interfaces>Eigenfrequency, Prestressed**.
- 4 Click **Add Study** in the window toolbar.
- 5 In the **Home** toolbar, click  **Add Study** to close the **Add Study** window.

STUDY 2

Step 1: Stationary

Note that the newly generated study combines one stationary analysis and one eigenfrequency analysis.

Step 2: Eigenfrequency

- 1 In the **Model Builder** window, click **Step 2: Eigenfrequency**.
- 2 In the **Settings** window for **Eigenfrequency**, locate the **Study Settings** section.
- 3 Select the **Desired number of eigenfrequencies** check box.
- 4 In the associated text field, type 10.
- 5 In the **Search for eigenfrequencies around** text field, type 100.
- 6 In the **Model Builder** window, click **Study 2**.
- 7 In the **Settings** window for **Study**, locate the **Study Settings** section.
- 8 Clear the **Generate default plots** check box.
- 9 In the **Home** toolbar, click  **Compute**.

RESULTS

Mode Shapes, Prestressed

- 1 In the **Model Builder** window, right-click **Mode Shapes, Original** and choose **Duplicate**.
- 2 In the **Model Builder** window, click **Mode Shapes, Original 1**.
- 3 In the **Settings** window for **3D Plot Group**, type **Mode Shapes, Prestressed** in the **Label** text field.
- 4 Locate the **Data** section. From the **Dataset** list, choose **Study 2/Solution 2 (sol2)**.

Surface 2

- 1 In the **Model Builder** window, click **Surface 2**.
- 2 In the **Settings** window for **Surface**, locate the **Data** section.
- 3 From the **Dataset** list, choose **Study 2/Solution 2 (sol2)**.

Surface 3

- 1 In the **Model Builder** window, click **Surface 3**.
- 2 In the **Settings** window for **Surface**, locate the **Data** section.
- 3 From the **Dataset** list, choose **Study 2/Solution 2 (sol2)**.

Surface 4

- 1 In the **Model Builder** window, click **Surface 4**.
- 2 In the **Settings** window for **Surface**, locate the **Data** section.
- 3 From the **Dataset** list, choose **Study 2/Solution 2 (sol2)**.

Surface 5

- 1 In the **Model Builder** window, click **Surface 5**.
- 2 In the **Settings** window for **Surface**, locate the **Data** section.
- 3 From the **Dataset** list, choose **Study 2/Solution 2 (sol2)**.

Surface 6

- 1 In the **Model Builder** window, click **Surface 6**.
- 2 In the **Settings** window for **Surface**, locate the **Data** section.
- 3 From the **Dataset** list, choose **Study 2/Solution 2 (sol2)**.
- 4 In the **Mode Shapes, Prestressed** toolbar, click  **Plot**.

In the settings for the second plot group you can see the list of the new eigenfrequencies. You can also find them tabulated in the **Eigenfrequencies (Study 2)** evaluation group

Global Evaluation 1

- 1 In the **Model Builder** window, under **Results>Derived Values** click **Global Evaluation 1**.
- 2 In the **Settings** window for **Global Evaluation**, locate the **Data** section.
- 3 From the **Dataset** list, choose **Study 2/Solution 2 (sol2)**.
- 4 Locate the **Expressions** section. In the table, enter the following settings:

| Expression | Unit | Description |
|------------|------|----------------------|
| freq | Hz | Frequency, Prestress |

- 5 Click  **Evaluate**.

Stress From Static Load

- 1 In the **Home** toolbar, click  **Add Plot Group** and choose **3D Plot Group**.
- 2 In the **Settings** window for **3D Plot Group**, type Stress From Static Load in the **Label** text field.
- 3 Locate the **Data** section. From the **Dataset** list, choose **Study 2/Solution Store 1 (sol3)**.

Surface 1

- 1 Right-click **Stress From Static Load** and choose **Surface**.
- 2 Click the  **Zoom Extents** button in the **Graphics** toolbar.
- 3 In the **Settings** window for **Surface**, locate the **Expression** section.
- 4 In the **Expression** text field, type `solid.mises`.
- 5 From the **Unit** list, choose **MPa**.
- 6 Locate the **Coloring and Style** section. From the **Color table** list, choose **Prism**.
- 7 From the **Color table transformation** list, choose **Nonlinear**.
- 8 In the **Color calibration parameter** text field, type `-1.4`.

Deformation 1

- 1 Right-click **Surface 1** and choose **Deformation**.
- 2 In the **Stress From Static Load** toolbar, click  **Plot**.

Arrow Surface 1

- 1 In the **Model Builder** window, right-click **Stress From Static Load** and choose **Arrow Surface**.
- 2 In the **Settings** window for **Arrow Surface**, click **Replace Expression** in the upper-right corner of the **Expression** section. From the menu, choose **Component 1 (comp1)>Solid Mechanics>Load>solid.F_Ax,...,solid.F_Az - Load (spatial frame)**.

- 3 Locate the **Coloring and Style** section. From the **Arrow base** list, choose **Head**.
- 4 Locate the **Arrow Positioning** section. From the **Placement** list, choose **Gauss points**.
- 5 Locate the **Coloring and Style** section. Select the **Scale factor** check box.
- 6 In the associated text field, type 7E-10.
- 7 Click to expand the **Inherit Style** section. From the **Plot** list, choose **Surface I**.
- 8 Clear the **Color** check box.
- 9 Clear the **Color and data range** check box.

Deformation I

- 1 Right-click **Arrow Surface I** and choose **Deformation**.
- 2 In the **Stress From Static Load** toolbar, click  **Plot**.

Eigenfrequency Comparison



- 1 In the **Home** toolbar, click  **Add Plot Group** and choose **ID Plot Group**.
- 2 In the **Settings** window for **ID Plot Group**, type Eigenfrequency Comparison in the **Label** text field.
- 3 Locate the **Plot Settings** section. Select the **y-axis label** check box.
- 4 In the associated text field, type Frequency [Hz].
- 5 Locate the **Grid** section. Select the **Manual spacing** check box.
- 6 Locate the **Legend** section. From the **Position** list, choose **Upper left**.

Table Graph I

- 1 Right-click **Eigenfrequency Comparison** and choose **Table Graph**.
- 2 In the **Settings** window for **Table Graph**, locate the **Data** section.
- 3 From the **x-axis data** list, choose **Row index**.
- 4 From the **Plot columns** list, choose **Manual**.
- 5 In the **Columns** list, choose **Frequency (Hz)** and **Frequency, Prestress (Hz)**.
- 6 Click to expand the **Legends** section. Select the **Show legends** check box.
- 7 Locate the **Coloring and Style** section. Find the **Line style** subsection. From the **Line** list, choose **None**.
- 8 Find the **Line markers** subsection. From the **Marker** list, choose **Cycle**.
- 9 From the **Positioning** list, choose **In data points**.
- 10 In the **Eigenfrequency Comparison** toolbar, click  **Plot**.
- 11 Click the  **y-Axis Log Scale** button in the **Graphics** toolbar.

