



Plasmonic Wire Grating

Introduction

A plane electromagnetic wave is incident on a wire grating on a dielectric substrate. The model computes transmission and reflection coefficients for the refraction, specular reflection, and first order diffraction.

Model Definition

Figure 1 shows the considered grating, with a gold wire on a dielectric material with refractive index n_β . The grating constant, or the distance between the wires, is d . A plane-polarized wave traveling through a medium with refractive index n_α is incident on the grating, at an angle α in a plane perpendicular to the grating.

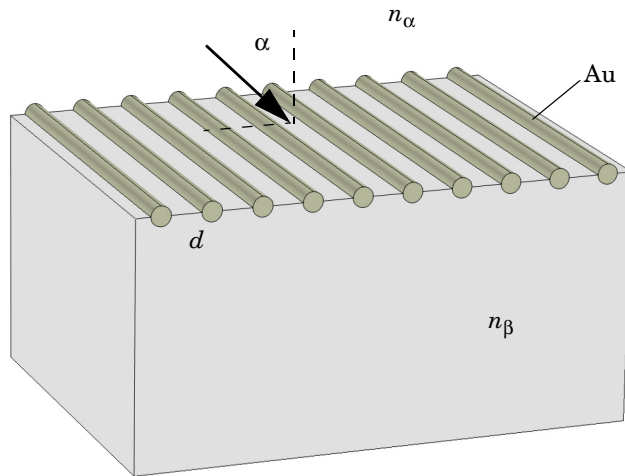

Figure 1: The modeled grating. The model considers a unit cell of a slice through this geometry. The grating is assumed to consist of an infinite number of infinitely long wires.

If the wavelengths involved in the model are sufficiently shorter than the grating constant, one or several diffraction orders can be present. The diagram in Figure 2 shows two

transmissive paths taken by light incident on adjacent cells of the grating, exactly one grating constant apart.

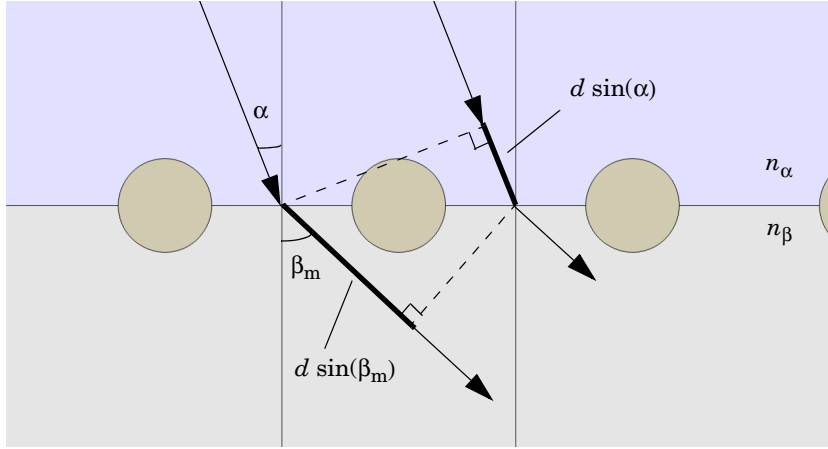

Figure 2: The geometric path lengths of two transmitted parallel beams. The optical path length is the geometric path length multiplied by the local refractive index.

The criterion for positive interference is that the difference in optical path length along the two paths equals an integer number of vacuum wavelengths, or:

$$m\lambda_0 = d(n_\beta \sin \beta_m - n_\alpha \sin \alpha) \quad (1)$$

with $m = 0, \pm 1, \pm 2, \dots$, λ_0 the vacuum wavelength, and β_m the transmitted diffracted beam of order m . For $m = 0$, this reduces to refraction, as described by Snell's law:

$$\sin \beta_0 = \frac{n_\alpha}{n_\beta} \sin \alpha$$

Because the sine functions can only vary between -1 and 1 , the existence of higher diffraction order requires that

$$-(n_\alpha + n_\beta) < \frac{m\lambda_0}{d} < (n_\alpha + n_\beta)$$

The model instructions cover only first order diffraction, and are hence only valid under the condition

$$2\lambda_0 > d(n_\alpha |\sin \alpha| + n_\beta) \quad (2)$$

Note that for the special cases of perpendicular and grazing incidence, the right-hand side of the inequality evaluates to $d n_\beta$ and $d(n_\alpha + n_\beta)$, respectively.

Figure 3 shows the corresponding paths of the reflected light.

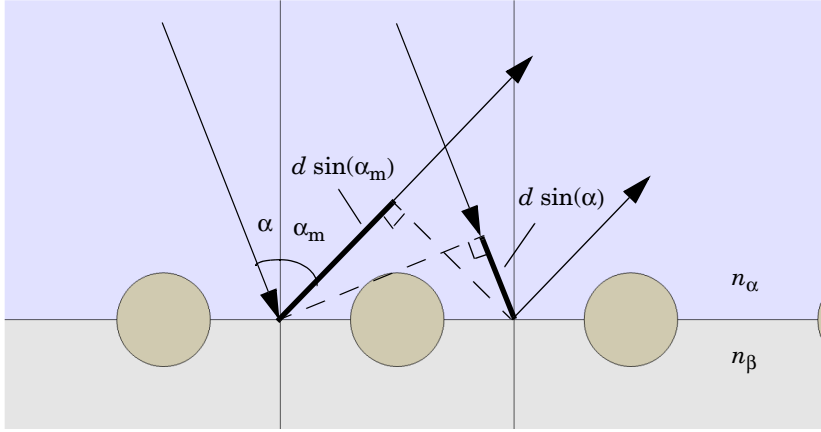

Figure 3: The geometric path lengths of two parallel reflected beams.

For positive interference we get

$$m\lambda_0 = dn_\alpha(\sin\alpha_m - \sin\alpha) \quad (3)$$

where α_m is the reflected beam of diffraction order m . Setting $m = 0$ in this equation renders

$$\sin\alpha_0 = \sin\alpha$$

or specular reflection. The condition for no reflected diffracted beams of order 2 or greater being present is

$$2\lambda_0 > dn_\alpha(1 + |\sin\alpha|) \quad (4)$$

The model uses $n_\alpha = 1$ for air and $n_\beta = 1.2$ for the dielectric substrate. Allowing for arbitrary angles of incidence and with a grating constant $d = 400$ nm, Equation 2 sets the validity limit to vacuum wavelengths greater than 440 nm. The model uses $\lambda_0 = 441$ nm. For the wire, a complex-valued permittivity of $-1.75 - 5.4i$ approximates that of gold at the corresponding frequency.

The performance of the grating depends on the polarization of the incident wave. Therefore both a transverse electric (TE) and a transverse magnetic (TM) case are considered. The TE wave has the electric field component in the z direction, out of the modeling xy -plane. For the TM wave, the electric field vector is pointing in the xy -plane and perpendicular to the direction of propagation, whereas the magnetic field has only a

component in the z direction. The angle of incidence is for both cases swept from 0 to $\pi/2$, with a pitch of $\pi/40$.

Results and Discussion

As an example of the output from the model, Figure 4 and Figure 5 show the electric field norm for an angle of incidence equal to $\pi/5$, for the TE and TM case respectively.

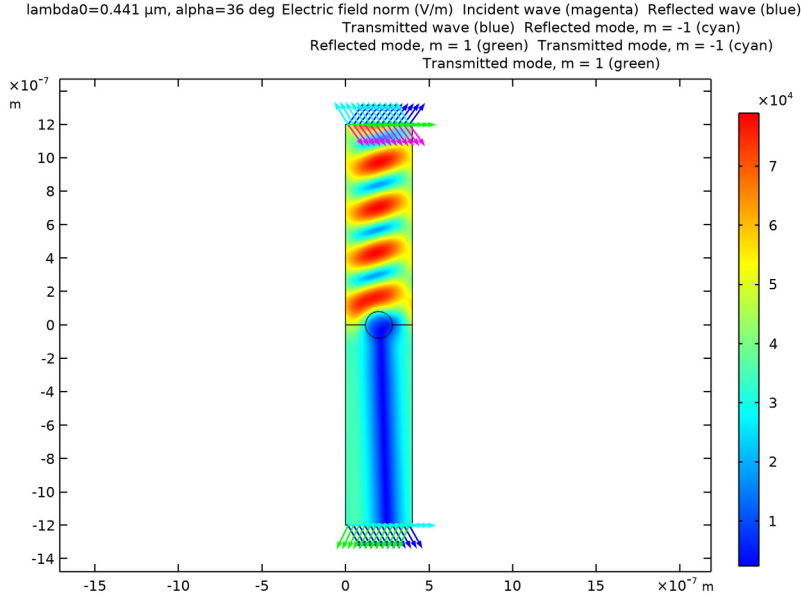

Figure 4: Electric field norm for TE incidence at $\pi/5$.

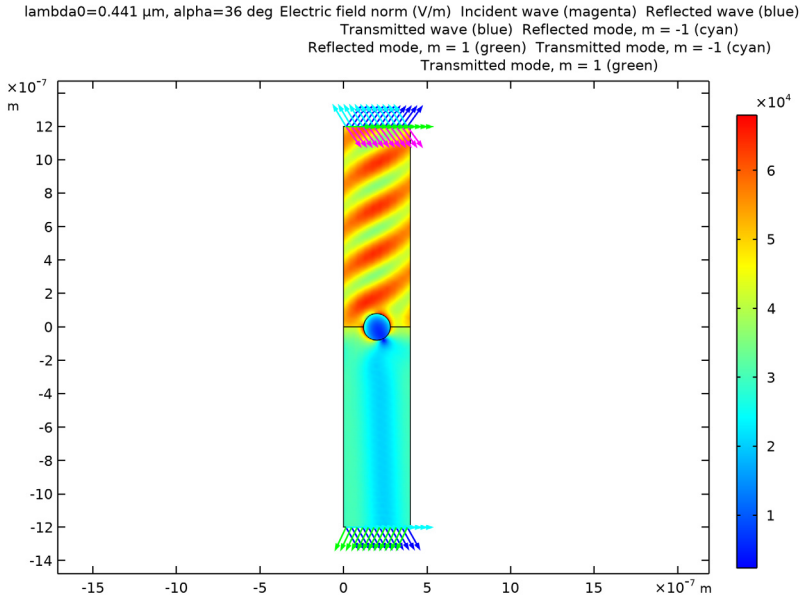

Figure 5: Electric field norm for TM incidence at $\pi/5$.

All the computed transmission and reflection coefficients for TE incidence are plotted in Figure 6. R_0 , the coefficient for specular reflection, increases rather steadily with the angle of incidence. This is both because of reflection in the material interface and because the wave “sees” the wire as increasingly wider at greater angles — the same effect as achieved by a Venetian blind. T_0 , the refracted but not diffracted transmission, decreases accordingly. For the considered wavelength to period length ratio, the transmitted diffracted beam T_{-1} is propagating only for nearly perpendicular incidence. The reflected diffraction order R_1 would need a shorter wavelength or a larger grating period to show up. Instead, the most prominent diffraction orders are R_{-1} and T_1 .

The sum of all coefficients is consistently less than 1 due to the dielectric losses in the wire. This is even more apparent for TM incidence, as Figure 7 shows. Here, approximately half of the wave is absorbed in the wire. Another important feature of the TM case is that there is very little specular reflection (R_0) around 60 degrees.

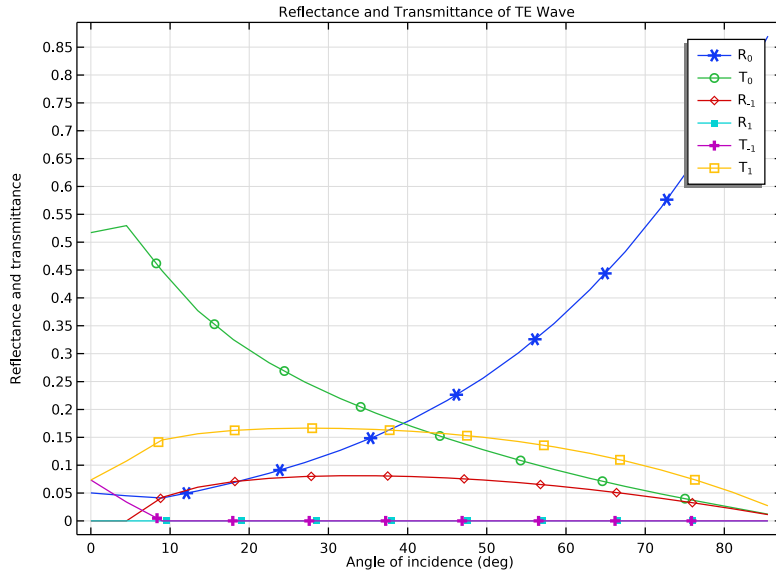

Figure 6: Transmission and reflection coefficients for TE incidence.

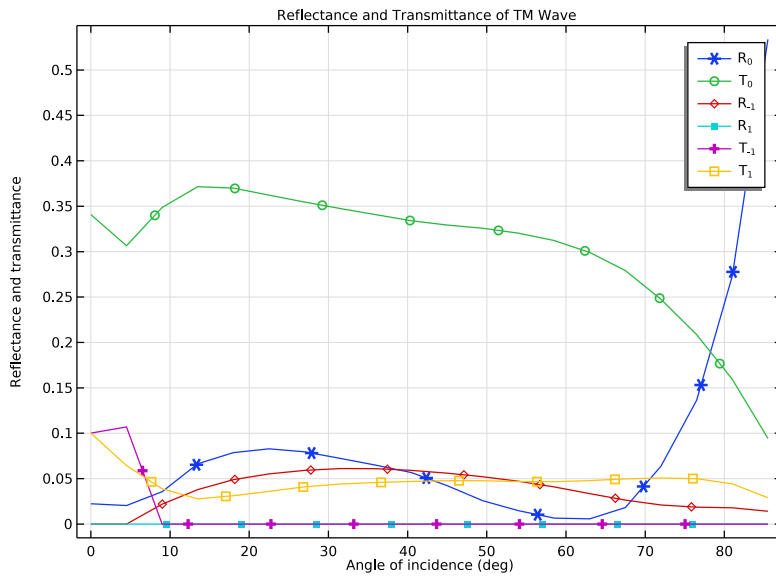

Figure 7: Transmission and reflection coefficients for TM incidence.

Notes About the COMSOL Implementation

The model is set up for one unit cell of the grating, flanked by Floquet boundary conditions describing the periodicity. As applied, this condition states that the solution on one side of the unit equals the solution on the other side multiplied by a complex-valued phase factor. The phase shift between the boundaries is evaluated from the perpendicular component of the wave vector. Because the periodicity boundaries are parallel with the y -axis, only the x -component is required. Due to the continuity of the field, the phase factor for the refracted and reflected beams is the same as for the incident wave.

Port conditions are used for specifying the incident wave and also for letting the resulting solution leave the model without any nonphysical reflections. In order to achieve perfect transmission through the port boundaries, one port for each mode ($m = 0, m = -1, m = 1$) in each direction must be present. This gives a total of 6 ports.

The input to each periodic port is an electric or magnetic field amplitude vector and an angle of incidence. The angle of incidence is defined as

$$\mathbf{k} \times \mathbf{n} = k \sin \alpha \mathbf{z}$$

where \mathbf{k} is the propagation vector of the incident wave, \mathbf{n} is the normalized normal vector, k is the wave number, α is the angle of incidence, and \mathbf{z} is the unit vector in the z direction. Note that this definition means that the angle of incidence on the opposite sides have opposite signs. To automatically create ports for the diffraction orders, you also provide the refractive index at the port boundary and the maximum frequency (which in this model is the single frequency that is used).

The table below lists the parameters names used in the model. “Internal” means that the variable is not provided as an input parameter.

TABLE I: PARAMETER NAMES.

MODEL DESCRIPTION	MODEL	DESCRIPTION
n_α	na	Refractive index, air
n_β	nb	Refractive index, dielectric
α	alpha	Angle of incidence
α_1	Internal	Reflected diffraction angle, order 1
α_{-1}	Internal	Reflected diffraction angle, order -1
β_0	beta	Refraction angle
β_1	Internal	Refracted diffraction angle, order 1
β_{-1}	Internal	Refracted diffraction angle, order -1

Application Library path: RF_Module/Tutorials/plasmonic_wire_grating



Modeling Instructions

From the **File** menu, choose **New**.

NEW

In the **New** window, click  **Model Wizard**.

MODEL WIZARD

- 1 In the **Model Wizard** window, click  **2D**.
- 2 In the **Select Physics** tree, select **Radio Frequency>Electromagnetic Waves, Frequency Domain (emw)**.
- 3 Click **Add**.
- 4 Click  **Study**.
- 5 In the **Select Study** tree, select **General Studies>Frequency Domain**.
- 6 Click  **Done**.

GLOBAL DEFINITIONS

Parameters I

- 1 In the **Model Builder** window, under **Global Definitions** click **Parameters I**.
- 2 In the **Settings** window for **Parameters**, locate the **Parameters** section.

3 In the table, enter the following settings:

Name	Expression	Value	Description
na	1	1	Refractive index, air
nb	1.2	1.2	Refractive index, dielectric
d	400[nm]	4E-7 m	Grating constant
lam0	441[nm]	4.41E-7 m	Vacuum wavelength
f0	c_const/lam0	6.798E14 1/s	Frequency
alpha	0[deg]	0 rad	Angle of incidence
beta	asin(na*sin(alpha)/nb)	0 rad	Refraction angle

Although the angle of incidence will not remain constant at 0, it needs to be specified as a parameter to be accessible to the parametric solver.

STUDY 1



Step 1: Frequency Domain

- 1 In the **Model Builder** window, under **Study 1** click **Step 1: Frequency Domain**.
- 2 In the **Settings** window for **Frequency Domain**, locate the **Study Settings** section.
- 3 In the **Frequencies** text field, type f0.

GEOMETRY 1

Create the geometry entirely in terms of the grating constant, for easy scalability.

Rectangle 1 (r1)

- 1 In the **Geometry** toolbar, click  **Rectangle**.
- 2 In the **Settings** window for **Rectangle**, locate the **Size and Shape** section.
- 3 In the **Width** text field, type d.
- 4 In the **Height** text field, type 3*d.
- 5 Click  **Build Selected**.

Rectangle 2 (r2)

- 1 In the **Geometry** toolbar, click  **Rectangle**.
- 2 In the **Settings** window for **Rectangle**, locate the **Size and Shape** section.
- 3 In the **Width** text field, type d.
- 4 In the **Height** text field, type 3*d.

5 Locate the **Position** section. In the **y** text field, type $-3*d$.

6 Click  **Build Selected**.

Circle 1 (c1)

1 In the **Geometry** toolbar, click  **Circle**.

2 In the **Settings** window for **Circle**, locate the **Size and Shape** section.

3 In the **Radius** text field, type $d/5$.

4 Locate the **Position** section. In the **x** text field, type $d/2$.

5 Click  **Build Selected**.

6 Click the  **Zoom Extents** button in the **Graphics** toolbar.

The geometry now consists of two rectangular domains for the air and the dielectric, and a circle centered on their intersection. You can remove the line through the circle if you first create a union of the objects.

Union 1 (un1)

1 In the **Geometry** toolbar, click  **Booleans and Partitions** and choose **Union**.

2 Click in the **Graphics** window and then press Ctrl+A to select all objects.

3 In the **Settings** window for **Union**, click  **Build Selected**.

Delete Entities 1 (del1)

1 In the **Model Builder** window, right-click **Geometry 1** and choose **Delete Entities**.

- 2 On the object **uni1**, select Boundary 6 only. This is the horizontal diameter of the circle in the center of the geometry.

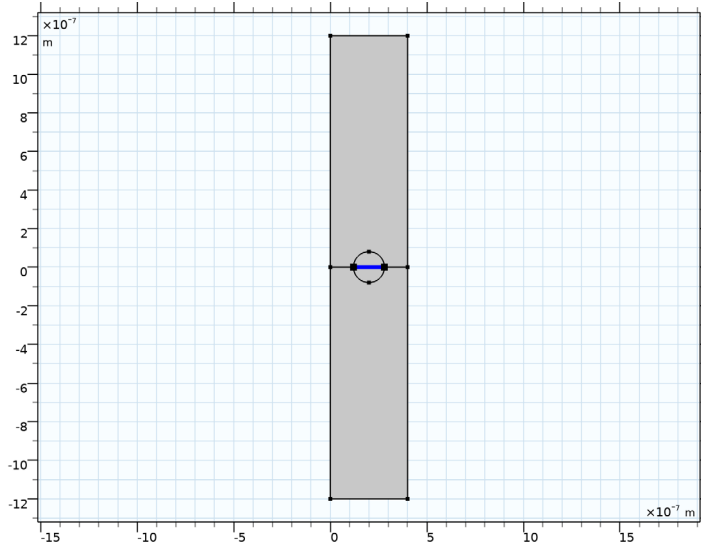

- 3 In the **Settings** window for **Delete Entities**, click  **Build Selected**.

Form Union (fin)

- 1 In the **Model Builder** window, click **Form Union (fin)**.

- 2 In the **Settings** window for **Form Union/Assembly**, click  **Build Selected**.

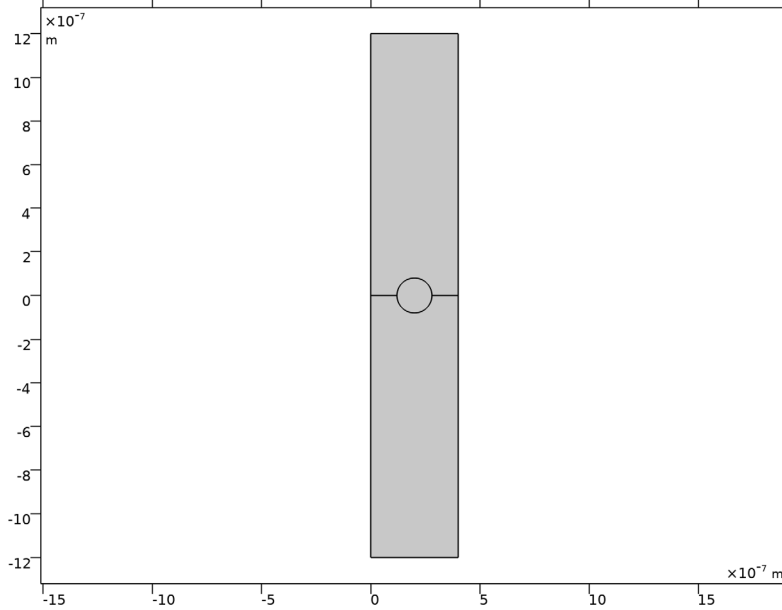

ELECTROMAGNETIC WAVES, FREQUENCY DOMAIN (EMW)

Before setting up the materials, define which constitutive relations you want to use in the Electromagnetic Waves interface.

Wave Equation, Electric 1

- 1 In the **Model Builder** window, under **Component 1 (comp1)**>**Electromagnetic Waves, Frequency Domain (emw)** click **Wave Equation, Electric 1**.
- 2 In the **Settings** window for **Wave Equation, Electric**, locate the **Electric Displacement Field** section.
- 3 From the **Electric displacement field model** list, choose **Refractive index**.

Wave Equation, Electric 2

- 1 In the **Physics** toolbar, click  **Domains** and choose **Wave Equation, Electric**.
- 2 Select Domain 3 only.

It might be easier to select the correct domain by using the **Selection List** window. To open this window, in the **Home** toolbar click **Windows** and choose **Selection List**. (If you are running the cross-platform desktop, you find **Windows** in the main menu.)

- 3 In the **Settings** window for **Wave Equation, Electric**, locate the **Electric Displacement Field** section.
- 4 From the **Electric displacement field model** list, choose **Dielectric loss**.

MATERIALS

Air

- 1 In the **Model Builder** window, under **Component 1 (comp1)** right-click **Materials** and choose **Blank Material**.
- 2 In the **Settings** window for **Material**, type **Air** in the **Label** text field.
- 3 Locate the **Material Contents** section. In the table, enter the following settings:

Property	Variable	Value	Unit	Property group
Refractive index, real part	n_iso ; nii = n_iso, nij = 0	na	l	Refractive index

Dielectric

- 1 Right-click **Materials** and choose **Blank Material**.
- 2 In the **Settings** window for **Material**, type **Dielectric** in the **Label** text field.
- 3 Select Domain 1 only.
- 4 Locate the **Material Contents** section. In the table, enter the following settings:

Property	Variable	Value	Unit	Property group
Refractive index, real part	n_iso ; nii = n_iso, nij = 0	nb	l	Refractive index

Gold

- 1 Right-click **Materials** and choose **Blank Material**.
- 2 In the **Settings** window for **Material**, type **Gold** in the **Label** text field.
- 3 Select Domain 3 only.

4 Locate the **Material Contents** section. In the table, enter the following settings:

Property	Variable	Value	Unit	Property group
Relative permittivity (imaginary part)	epsilonBis_iso ; epsilonBisii = epsilonBis_iso, epsilonBisij = 0	5.4	l	Dielectric losses
Relative permittivity (real part)	epsilonPrim_iso ; epsilonPrimii = epsilonPrim_iso, epsilonPrimij = 0	-1.75	l	Dielectric losses
Relative permeability	mur_iso ; murii = mur_iso, murij = 0	1	l	Basic
Electrical conductivity	sigma_iso ; sigmaii = sigma_iso, sigmaij = 0	0	S/m	Basic

ELECTROMAGNETIC WAVES, FREQUENCY DOMAIN (EMW)

In the first version of this model, you will assume a TE-polarized wave. This means that E_x and E_y will be zero throughout the geometry, and that you consequently only need to solve for E_z .

- 1 In the **Model Builder** window, under **Component 1 (comp1)** click **Electromagnetic Waves, Frequency Domain (emw)**.
- 2 In the **Settings** window for **Electromagnetic Waves, Frequency Domain**, locate the **Components** section.
- 3 From the **Electric field components solved for** list, choose **Out-of-plane vector**.

Port 1

Now define the excitation port. A periodic port assumes that the structure is periodic and simplifies the setup of ports for the diffraction orders.

- 1 In the **Physics** toolbar, click  **Boundaries** and choose **Port**.
- 2 Select Boundary 5 only.

It might be easier to select the correct boundary by using the **Selection List** window. To open this window, in the **Home** toolbar click **Windows** and choose **Selection List**. (If you are running the cross-platform desktop, you find **Windows** in the main menu.)

- 3 In the **Settings** window for **Port**, locate the **Port Properties** section.

4 From the **Type of port** list, choose **Periodic**.

For the first port, wave excitation is **on** by default.

Notice that you define the electric field by only setting the amplitude. A phase factor should not be entered.

5 Locate the **Port Mode Settings** section. Specify the \mathbf{E}_0 vector as

0	x
0	y
1	z

6 In the α text field, type alpha.

7 Locate the **Automatic Diffraction Order Calculation** section. In the n text field, type na.

The order in which you set up the ports will determine how the S-parameters are labeled. You have just created Port 1 for the excitation. If you set up the next port for the transmission of the purely refracted beam, the S21-parameter will contain information on the zero order transmission.

Notice that for the exciting port (**Port 1**) there are no propagating diffraction orders for normal incidence. Instead, manually add the **Diffraction Order** port subfeatures.

8 Clear the **Include in automatic diffraction order calculation** check box, to *not* remove the manually added **Diffraction Order** port subfeatures below this port when you later will click the **Add Diffraction Orders** button.

Port 2

1 In the **Physics** toolbar, click  **Boundaries** and choose **Port**.

2 Select Boundary 2 only.

3 In the **Settings** window for **Port**, locate the **Port Properties** section.

4 From the **Type of port** list, choose **Periodic**.

5 Locate the **Port Mode Settings** section. Specify the \mathbf{E}_0 vector as

0	x
0	y
1	z

For the listener port you only need to provide the refractive index for the automatic generation of Diffraction Order ports. The propagation angle is automatically determined from Snell's law, give the angle of incidence for the exciting periodic port and the refractive indices provided for the exciting port and this listener port.

6 Locate the **Automatic Diffraction Order Calculation** section. In the n text field, type nb.

Port 1

Now manually add the ports for the reflected diffraction orders.

1 In the **Model Builder** window, click **Port 1**.

Diffraction Order 1

1 In the **Physics** toolbar, click  **Attributes** and choose **Diffraction Order**.

2 In the **Settings** window for **Diffraction Order**, locate the **Port Mode Settings** section.

3 From the **Components** list, choose **Out-of-plane vector**.

4 In the m text field, type -1.

Diffraction Order 2

1 Right-click **Diffraction Order 1** and choose **Duplicate**.

2 In the **Settings** window for **Diffraction Order**, locate the **Port Mode Settings** section.

3 In the m text field, type 1.

Port 1

Finally, automatically add the ports for the transmitted diffraction orders.

1 In the **Model Builder** window, click **Port 1**.

2 In the **Settings** window for **Port**, locate the **Automatic Diffraction Order Calculation** section.

3 Click **Add Diffraction Orders**.

Inspect the **Diffraction Order** port subfeatures by expanding the **Port 2** node.

Periodic Condition 1

1 In the **Model Builder** window, expand the **Port 2** node.

2 Right-click **Electromagnetic Waves, Frequency Domain (emw)** and choose **Periodic Condition**.

3 Select Boundaries 1, 3, 7, and 8 only.

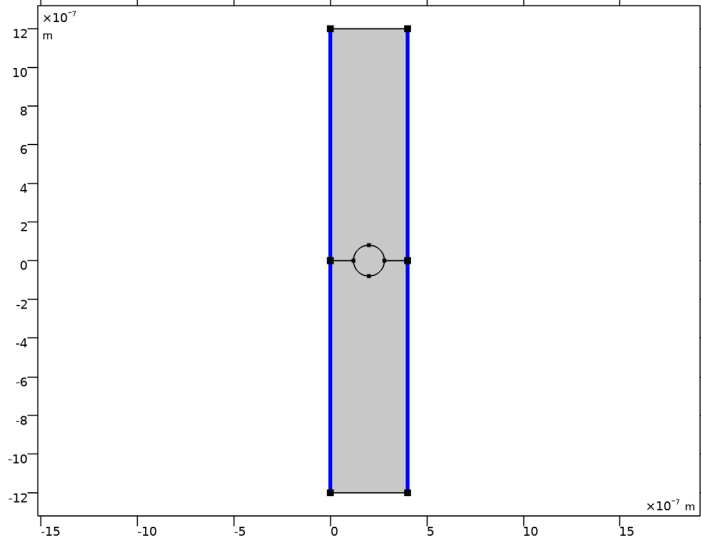

4 In the **Settings** window for **Periodic Condition**, locate the **Periodicity Settings** section.

5 From the **Type of periodicity** list, choose **Floquet periodicity**.

The wave vector in the direction for the periodicity is used by the periodic port. Thus, you can use that wave vector also for the Floquet periodic condition.

6 From the **k-vector for Floquet periodicity** list, choose **From periodic port**.

MESH 1

The periodic boundary conditions perform better if the mesh is identical on the periodicity boundaries. This is especially important when dealing with vector degrees of freedom, as will be the case in the TM version of this model.

1 In the **Model Builder** window, under **Component 1 (comp1)** click **Mesh 1**.

2 In the **Settings** window for **Mesh**, locate the **Physics-Controlled Mesh** section.

3 In the table, clear the **Use** check box for **Electromagnetic Waves, Frequency Domain (emw)**.

4 Locate the **Sequence Type** section. From the list, choose **User-controlled mesh**.

Free Triangular 1

In the **Model Builder** window, under **Component 1 (comp1)>Mesh 1** right-click **Free Triangular 1** and choose **Delete**.

Size

- 1 In the **Model Builder** window, under **Component 1 (comp1)>Mesh 1** click **Size**.
- 2 In the **Settings** window for **Size**, locate the **Element Size** section.
- 3 From the **Predefined** list, choose **Extra fine**.

Edge 1

- 1 In the **Mesh** toolbar, click  **Edge**.
- 2 Select Boundaries 1 and 3 only.

Copy Edge 1

- 1 In the **Model Builder** window, right-click **Mesh 1** and choose **Copying Operations>Copy Edge**.
- 2 Select Boundary 3 only.
- 3 In the **Settings** window for **Copy Edge**, locate the **Destination Boundaries** section.
- 4 Click to select the  **Activate Selection** toggle button.
- 5 Select Boundary 8 only.

Copy Edge 2

- 1 Right-click **Mesh 1** and choose **Copying Operations>Copy Edge**.
- 2 Select Boundary 1 only.
- 3 In the **Settings** window for **Copy Edge**, locate the **Destination Boundaries** section.
- 4 Click to select the  **Activate Selection** toggle button.
- 5 Select Boundary 7 only.

Free Triangular 1

- 1 In the **Mesh** toolbar, click  **Free Triangular**.
- 2 In the **Settings** window for **Free Triangular**, click  **Build All**.

STUDY 1

To set up the study to sweep for the angle of incidence, some modifications of the solver are required.

Parametric Sweep

- 1 In the **Study** toolbar, click  **Parametric Sweep**.
- 2 In the **Settings** window for **Parametric Sweep**, locate the **Study Settings** section.
- 3 Click **+ Add**.
- 4 From the list in the **Parameter name** column, choose **alpha (Angle of incidence)**.

- 5 Click  **Range**.
- 6 In the **Range** dialog box, type $0[\text{rad}]$ in the **Start** text field.
- 7 In the **Step** text field, type $\pi/40[\text{rad}]$.
- 8 In the **Stop** text field, type $(\pi/2-\pi/40)[\text{rad}]$.
- 9 Click **Replace**.
- 10 In the **Settings** window for **Parametric Sweep**, locate the **Study Settings** section.
- 11 In the table, enter the following settings:

Parameter name	Parameter value list	Parameter unit
alpha (Angle of incidence)	range($0[\text{rad}]$, $\pi/40[\text{rad}]$, $(\pi/2-\pi/40)[\text{rad}]$)	deg

- 12 In the **Study** toolbar, click  **Compute**.

RESULTS

Add arrow plots for the incident wave vector of the excitation port and the mode wave vector of each diffraction order.

Arrow Line 1

- 1 Right-click **Electric Field (emw)** and choose **Arrow Line**.
- 2 In the **Settings** window for **Arrow Line**, click **Replace Expression** in the upper-right corner of the **Expression** section. From the menu, choose **Component 1 (comp1)> Electromagnetic Waves, Frequency Domain>Ports>emw.kIncx_1,emw.kIncy_1 - Incident wave vector**.
- 3 Locate the **Coloring and Style** section. From the **Color** list, choose **Magenta**.
- 4 Locate the **Expression** section. Select the **Description** check box.
- 5 In the associated text field, type Incident wave (magenta).

Arrow Line 2

- 1 Right-click **Electric Field (emw)** and choose **Arrow Line**.
- 2 In the **Settings** window for **Arrow Line**, click **Replace Expression** in the upper-right corner of the **Expression** section. From the menu, choose **Component 1 (comp1)> Electromagnetic Waves, Frequency Domain>Ports>emw.kModex_1,emw.kModey_1 - Port mode wave vector**.
- 3 Locate the **Coloring and Style** section. From the **Color** list, choose **Blue**.
- 4 Locate the **Expression** section. Select the **Description** check box.
- 5 In the associated text field, type Reflected wave (blue).

Arrow Line 3

- 1 Right-click **Electric Field (emw)** and choose **Arrow Line**.
- 2 In the **Settings** window for **Arrow Line**, click **Replace Expression** in the upper-right corner of the **Expression** section. From the menu, choose **Component 1 (comp1)> Electromagnetic Waves, Frequency Domain>Ports>emw.kModex_2,emw.kModey_2 - Port mode wave vector**.
- 3 Locate the **Coloring and Style** section. From the **Color** list, choose **Blue**.
- 4 Locate the **Expression** section. Select the **Description** check box.
- 5 In the associated text field, type Transmitted wave (blue).

Arrow Line 4

- 1 Right-click **Electric Field (emw)** and choose **Arrow Line**.
- 2 In the **Settings** window for **Arrow Line**, click **Replace Expression** in the upper-right corner of the **Expression** section. From the menu, choose **Component 1 (comp1)> Electromagnetic Waves, Frequency Domain>Ports>emw.kModex_3,emw.kModey_3 - Port mode wave vector**.
- 3 Locate the **Coloring and Style** section. From the **Color** list, choose **Cyan**.
- 4 Locate the **Expression** section. Select the **Description** check box.
- 5 In the associated text field, type Reflected mode, $m = -1$ (cyan).

Arrow Line 5

- 1 Right-click **Arrow Line 4** and choose **Duplicate**.
- 2 In the **Settings** window for **Arrow Line**, click **Replace Expression** in the upper-right corner of the **Expression** section. From the menu, choose **Component 1 (comp1)> Electromagnetic Waves, Frequency Domain>Ports>emw.kModex_4,emw.kModey_4 - Port mode wave vector**.
- 3 Locate the **Coloring and Style** section. From the **Color** list, choose **Green**.
- 4 Locate the **Expression** section. In the **Description** text field, type Reflected mode, $m = 1$ (green).

Arrow Line 6

- 1 In the **Model Builder** window, under **Results>Electric Field (emw)** right-click **Arrow Line 4** and choose **Duplicate**.
- 2 In the **Settings** window for **Arrow Line**, locate the **Expression** section.
- 3 In the **X component** text field, type `emw.kModex_5`.
- 4 In the **Y component** text field, type `emw.kModey_5`.

5 In the **Description** text field, type Transmitted mode, $m = -1$ (cyan).



Arrow Line 7

- 1 In the **Model Builder** window, under **Results>Electric Field (emw)** right-click **Arrow Line 5** and choose **Duplicate**.
- 2 In the **Settings** window for **Arrow Line**, locate the **Expression** section.
- 3 In the **X component** text field, type `emw.kModex_6`.
- 4 In the **Y component** text field, type `emw.kModey_6`.
- 5 In the **Description** text field, type Transmitted mode, $m = 1$ (green).

TE Electric Field

- 1 In the **Model Builder** window, under **Results** click **Electric Field (emw)**.
- 2 In the **Settings** window for **2D Plot Group**, type TE Electric Field in the **Label** text field.

The default plot shows the electric field norm for the last solution, almost tangential incidence. Look at a more interesting angle of incidence.

- 3 Locate the **Data** section. From the **Parameter value (alpha (deg))** list, choose **36**.
Make the title slightly shorter.
- 4 Click to expand the **Title** section. From the **Title type** list, choose **Custom**.
- 5 Find the **Type and data** subsection. Clear the **Type** check box.
- 6 In the **TE Electric Field** toolbar, click  **Plot**.
- 7 Click the  **Zoom Extents** button in the **Graphics** toolbar. The plot should now look like [Figure 4](#).

1D Plot Group TE

Modify the generated 1D plot of the diffraction efficiencies for the different orders versus the angle of incidence.

- 1 In the **Model Builder** window, under **Results** click **S-parameter (emw)**.
- 2 In the **Settings** window for **1D Plot Group**, type 1D Plot Group TE in the **Label** text field.
- 3 Click to expand the **Title** section. From the **Title type** list, choose **Manual**.
- 4 In the **Title** text area, type Reflectance and Transmittance of TE Wave.
- 5 Locate the **Plot Settings** section. In the **y-axis label** text field, type Reflectance and transmittance.

Global I

Plot the linear-scale reflectances and transmittances, instead of the dB-scale S-parameters.

- 1 In the **Model Builder** window, expand the **ID Plot Group TE** node, then click **Global I**.
- 2 In the **Settings** window for **Global**, locate the **y-Axis Data** section.
- 3 In the table, enter the following settings:

Expression	Unit	Description
$\text{abs}(\text{emw.S11})^2$	1	
$\text{abs}(\text{emw.S21})^2$	1	
$\text{abs}(\text{emw.S31})^2$	1	
$\text{abs}(\text{emw.S41})^2$	1	
$\text{abs}(\text{emw.S51})^2$	1	
$\text{abs}(\text{emw.S61})^2$	1	

- 4 Click to expand the **Coloring and Style** section. Find the **Line markers** subsection. From the **Marker** list, choose **Cycle**.
- 5 Click to expand the **Legends** section. From the **Legends** list, choose **Manual**.
- 6 In the table, enter the following settings:

Legends
R_{00}
T_{00}
R_{01}
R_{10}
T_{01}
T_{10}

- 7 In the **ID Plot Group TE** toolbar, click  **Plot**. The plot should now look like [Figure 6](#).

Smith Plot TE

- 1 In the **Model Builder** window, under **Results** click **Smith Plot (emw)**.
- 2 In the **Settings** window for **Smith Plot Group**, type Smith Plot TE in the **Label** text field.

Reflection Graph I

In the **Model Builder** window, expand the **Smith Plot TE** node.

Color Expression I

- 1 In the **Model Builder** window, expand the **Reflection Graph I** node, then click **Color Expression I**.
- 2 In the **Settings** window for **Color Expression**, locate the **Expression** section.
- 3 In the **Expression** text field, type alpha.

4 From the **Unit** list, choose °.

Reflection Graph 1

- 1 In the **Model Builder** window, click **Reflection Graph 1**.
- 2 In the **Settings** window for **Reflection Graph**, click to expand the **Title** section.
- 3 In the **Title** text area, type Reflection Graph TE: S-parameter, Color: Angle of Incidence (degrees).

ELECTROMAGNETIC WAVES, FREQUENCY DOMAIN (EMW)

The remaining instructions show how to alter the physics so that you solve for an incident TM wave.

- 1 In the **Model Builder** window, under **Component 1 (comp1)** click **Electromagnetic Waves, Frequency Domain (emw)**.
- 2 In the **Settings** window for **Electromagnetic Waves, Frequency Domain**, locate the **Components** section.
- 3 From the **Electric field components solved for** list, choose **In-plane vector**.

You will now solve for E_x and E_y instead of E_z ; for a TM wave, E_z is zero.

Port 1

The easiest way to specify a TM wave is to define the magnetic field, since only the z component is used.

- 1 In the **Model Builder** window, under **Component 1 (comp1)**>**Electromagnetic Waves, Frequency Domain (emw)** click **Port 1**.
- 2 In the **Settings** window for **Port**, locate the **Port Mode Settings** section.
- 3 From the **Input quantity** list, choose **Magnetic field**.
- 4 Specify the \mathbf{H}_0 vector as

0	x
0	y
1	z

- 5 Locate the **Automatic Diffraction Order Calculation** section. Click **Add Diffraction Orders**, to update the **Diffraction Order** port subfeatures below **Port 2**.

Diffraction Order 1

The **Diffraction Order** port subfeatures below this port (**Port 1**) must be updated manually.

- 1 In the **Model Builder** window, click **Diffraction Order 1**.

- 2 In the **Settings** window for **Diffraction Order**, locate the **Port Mode Settings** section.
- 3 From the **Components** list, choose **In-plane vector**.

Diffraction Order 2

- 1 In the **Model Builder** window, click **Diffraction Order 2**.
- 2 In the **Settings** window for **Diffraction Order**, locate the **Port Mode Settings** section.
- 3 From the **Components** list, choose **In-plane vector**.

Port 2



- 1 In the **Model Builder** window, under **Component 1 (comp1)>Electromagnetic Waves, Frequency Domain (emw)** click **Port 2**.
- 2 In the **Settings** window for **Port**, locate the **Port Mode Settings** section.
- 3 From the **Input quantity** list, choose **Magnetic field**.
- 4 Specify the \mathbf{H}_0 vector as

0	x
0	y
1	z

ROOT

Add a new study in order not to overwrite the TE solution.

ADD STUDY

- 1 In the **Home** toolbar, click  **Add Study** to open the **Add Study** window.
- 2 Go to the **Add Study** window.
- 3 Find the **Studies** subsection. In the **Select Study** tree, select **General Studies>Frequency Domain**.
- 4 Click **Add Study** in the window toolbar.
- 5 In the **Home** toolbar, click  **Add Study** to close the **Add Study** window.

STUDY 2

Step 1: Frequency Domain

- 1 In the **Settings** window for **Frequency Domain**, locate the **Study Settings** section.
- 2 In the **Frequencies** text field, type f0.

Parametric Sweep

- 1 In the **Study** toolbar, click  **Parametric Sweep**.

- 2 In the **Settings** window for **Parametric Sweep**, locate the **Study Settings** section.
- 3 Click **+ Add**.
- 4 From the list in the **Parameter name** column, choose **alpha (Angle of incidence)**.
- 5 Click **Range**.
- 6 In the **Range** dialog box, type $0[\text{rad}]$ in the **Start** text field.
- 7 In the **Step** text field, type $\pi/40[\text{rad}]$.
- 8 In the **Stop** text field, type $(\pi/2-\pi/40)[\text{rad}]$.
- 9 Click **Replace**.
- 10 In the **Settings** window for **Parametric Sweep**, locate the **Study Settings** section.
- 11 In the table, enter the following settings:

Parameter name	Parameter value list	Parameter unit
alpha (Angle of incidence)	range($0[\text{rad}]$, $\pi/40[\text{rad}]$, $(\pi/2-\pi/40)[\text{rad}]$)	deg

- 12 In the **Study** toolbar, click **= Compute**.

RESULTS

Arrow Line 1

- 1 Right-click **Electric Field (emw)** and choose **Arrow Line**.
- 2 In the **Settings** window for **Arrow Line**, click **Replace Expression** in the upper-right corner of the **Expression** section. From the menu, choose **Component 1 (comp1)> Electromagnetic Waves, Frequency Domain>Ports>emw.klncx_1,emw.klncy_1 - Incident wave vector**.
- 3 Locate the **Coloring and Style** section. From the **Color** list, choose **Magenta**.
- 4 Locate the **Expression** section. Select the **Description** check box.
- 5 In the associated text field, type Incident wave (magenta).

Arrow Line 2

- 1 Right-click **Electric Field (emw)** and choose **Arrow Line**.
- 2 In the **Settings** window for **Arrow Line**, click **Replace Expression** in the upper-right corner of the **Expression** section. From the menu, choose **Component 1 (comp1)> Electromagnetic Waves, Frequency Domain>Ports>emw.kModex_1,emw.kMody_1 - Port mode wave vector**.
- 3 Locate the **Coloring and Style** section. From the **Color** list, choose **Blue**.

- 4 Locate the **Expression** section. Select the **Description** check box.
- 5 In the associated text field, type Reflected wave (blue).

Arrow Line 3

- 1 Right-click **Electric Field (emw)** and choose **Arrow Line**.
- 2 In the **Settings** window for **Arrow Line**, click **Replace Expression** in the upper-right corner of the **Expression** section. From the menu, choose **Component 1 (comp1)> Electromagnetic Waves, Frequency Domain>Ports>emw.kModex_2,emw.kModey_2 - Port mode wave vector**.
- 3 Locate the **Coloring and Style** section. From the **Color** list, choose **Blue**.
- 4 Locate the **Expression** section. Select the **Description** check box.
- 5 In the associated text field, type Transmitted wave (blue).

Arrow Line 4

- 1 Right-click **Electric Field (emw)** and choose **Arrow Line**.
- 2 In the **Settings** window for **Arrow Line**, click **Replace Expression** in the upper-right corner of the **Expression** section. From the menu, choose **Component 1 (comp1)> Electromagnetic Waves, Frequency Domain>Ports>emw.kModex_3,emw.kModey_3 - Port mode wave vector**.
- 3 Locate the **Coloring and Style** section. From the **Color** list, choose **Cyan**.
- 4 Locate the **Expression** section. Select the **Description** check box.
- 5 In the associated text field, type Reflected mode, $m = -1$ (cyan).

Arrow Line 5

- 1 Right-click **Arrow Line 4** and choose **Duplicate**.
- 2 In the **Settings** window for **Arrow Line**, click **Replace Expression** in the upper-right corner of the **Expression** section. From the menu, choose **Component 1 (comp1)> Electromagnetic Waves, Frequency Domain>Ports>emw.kModex_4,emw.kModey_4 - Port mode wave vector**.
- 3 Locate the **Coloring and Style** section. From the **Color** list, choose **Green**.
- 4 Locate the **Expression** section. In the **Description** text field, type Reflected mode, $m = 1$ (green).

Arrow Line 6



- 1 In the **Model Builder** window, under **Results>Electric Field (emw)** right-click **Arrow Line 4** and choose **Duplicate**.
- 2 In the **Settings** window for **Arrow Line**, locate the **Expression** section.

- 3 In the **X component** text field, type `emw.kModex_5`.
- 4 In the **Y component** text field, type `emw.kModey_5`.
- 5 In the **Description** text field, type Transmitted mode, $m = -1$ (cyan).

Arrow Line 7

- 1 In the **Model Builder** window, under **Results>Electric Field (emw)** right-click **Arrow Line 5** and choose **Duplicate**.
- 2 In the **Settings** window for **Arrow Line**, locate the **Expression** section.
- 3 In the **X component** text field, type `emw.kModex_6`.
- 4 In the **Y component** text field, type `emw.kModey_6`.
- 5 In the **Description** text field, type Transmitted mode, $m = 1$ (green).

TM Electric Field

- 1 In the **Model Builder** window, under **Results** click **Electric Field (emw)**.
- 2 In the **Settings** window for **2D Plot Group**, type TM Electric Field in the **Label** text field.
- 3 Locate the **Data** section. From the **Parameter value (alpha (deg))** list, choose **36**.
- 4 Locate the **Title** section. From the **Title type** list, choose **Custom**.
- 5 Find the **Type and data** subsection. Clear the **Type** check box.
- 6 In the **TM Electric Field** toolbar, click  **Plot**.
- 7 Click the  **Zoom Extents** button in the **Graphics** toolbar. You have now reproduced [Figure 5](#).

S-parameter (emw)

Delete this plot and duplicate 1D Plot Group TM instead, to create the TM reflectance and transmittance plot.

- 1 In the **Model Builder** window, under **Results** right-click **S-parameter (emw)** and choose **Delete**.

1D Plot Group TM

- 1 In the **Model Builder** window, right-click **ID Plot Group TE** and choose **Duplicate**.
- 2 In the **Settings** window for **ID Plot Group**, type 1D Plot Group TM in the **Label** text field.
- 3 Locate the **Title** section. In the **Title** text area, type Reflectance and Transmittance of TM Wave.
- 4 Locate the **Data** section. From the **Dataset** list, choose **Study 2/Solution 2 (sol2)**.

5 In the **ID Plot Group TM** toolbar, click  **Plot**.

Compare the resulting plot with that in [Figure 7](#).

Smith Plot TM

1 In the **Model Builder** window, under **Results** click **Smith Plot (emw)**.

2 In the **Settings** window for **Smith Plot Group**, type Smith Plot TM in the **Label** text field.

Reflection Graph I

In the **Model Builder** window, expand the **Smith Plot TM** node.

Color Expression I

1 In the **Model Builder** window, expand the **Reflection Graph I** node, then click **Color Expression I**.

2 In the **Settings** window for **Color Expression**, locate the **Expression** section.

3 In the **Expression** text field, type alpha.

4 From the **Unit** list, choose °.

Reflection Graph I

1 In the **Model Builder** window, click **Reflection Graph I**.

2 In the **Settings** window for **Reflection Graph**, locate the **Title** section.

3 In the **Title** text area, type Reflection Graph TM: S-parameter, Color: Angle of Incidence (degrees).

