



# Dielectric Resonator Antenna

## Introduction

---

In this example, a slot antenna is augmented by placing a dielectric block structure above the antenna. This block has additional metallic elements patterned on it that act as a lens and guide the radiation pattern and increase the directivity. The model is shown in [Figure 1](#).

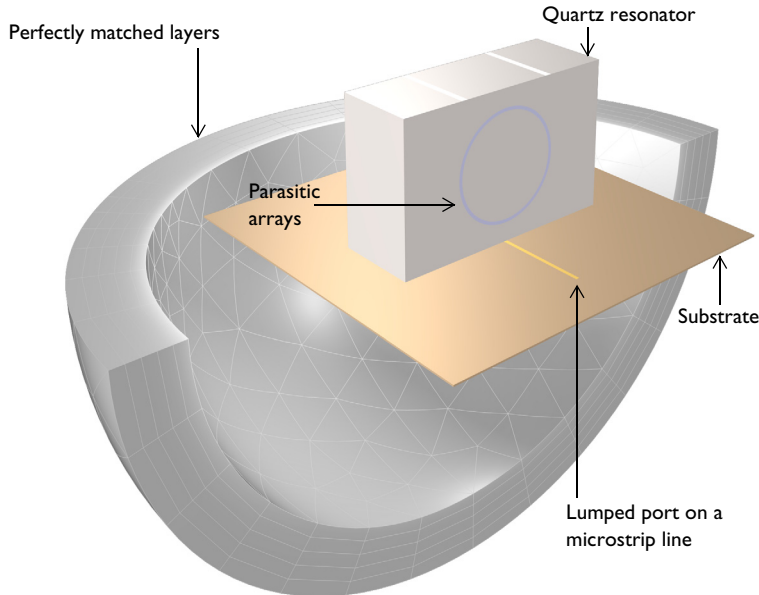

*Figure 1: Slot coupled dielectric resonator antenna with parasitic arrays. Only one-quarter of the entire PMLs are shown in this figure.*

## Model Definition

---

A slot antenna is formed by cutting out a rectangular section from a ground plane. This slot antenna is fed from a  $50 \Omega$  microstrip line which is fed from a  $50 \Omega$  lumped port, representing the power source. The microstrip line extends some distance past the slot, forming a tuning stub. Both the ground plane and the microstrip line are treated as being infinitely thin, and are assumed to be perfect electric conductor (PEC) surfaces.

A block of quartz dielectric, is placed above the slot antenna. This block acts as a resonant structure, but also as a radiating element. The directivity of the radiation pattern is improved by patterning additional metal layers onto the block. In this example, two strips are added along the top, and two loops are added along each face. These layers are

modeled as infinitely thin PEC faces. The dimensions of these elements are chosen such that they are resonant at the operating frequency of 2.9 GHz. These additional unfed elements act to increase the directivity of the antenna structure.

The entire antenna structure is modeled within a sphere with the properties of vacuum. This sphere is truncated by a perfectly matched layer (PML) domain that acts as a boundary to free space. The distance from the antenna to the PML is a variable that does require some study. The PML should not be within the reactive near-field region of the antenna structure. However, the size of the reactive near-field is not strictly definable, so the distance from the antenna to the PML should be studied for each model. It should be placed far enough away as not have negligible effect upon the results. The thickness of the PML itself is not critical, and can be made approximately one-tenth the air sphere diameter.

The meshing of radiating structures requires some care. As a rule of thumb, at least five elements per wavelength in each material are suggested, although if absolutely necessary, as few as three elements can be used. Additionally, curved edges and surfaces should be meshed with at least two elements per  $90^\circ$  chord, and the stricter of the two criteria should always be used. Additionally, tetrahedral elements of approximately unit aspect ratio are preferred in most modeling regions, with the exception of the PML domains. Since the PML domain preferentially absorbs radiated energy in one direction, the mesh should conform to this. A swept mesh is thus recommended in PML regions.

## Results and Discussion

The structure is solved for an operating frequency of 2.9 GHz. The far-field radiation patterns are shown in Figure 2 and Figure 3. The radiation guided by the dielectric resonator and metallic strips is directional toward the top side.

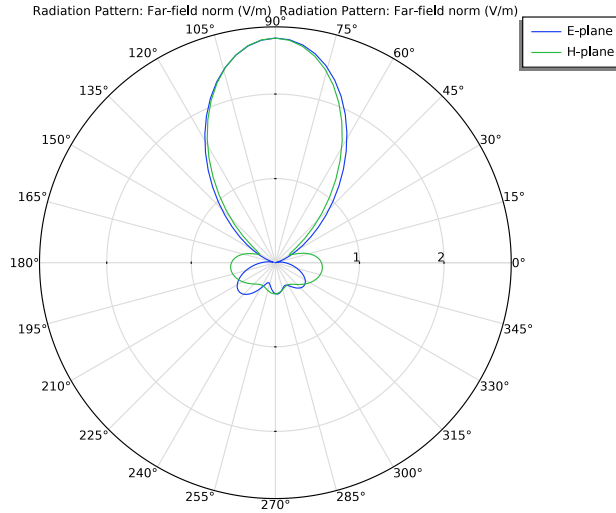

Figure 2: Far-field radiation pattern on the E-plane at 2.9 GHz.

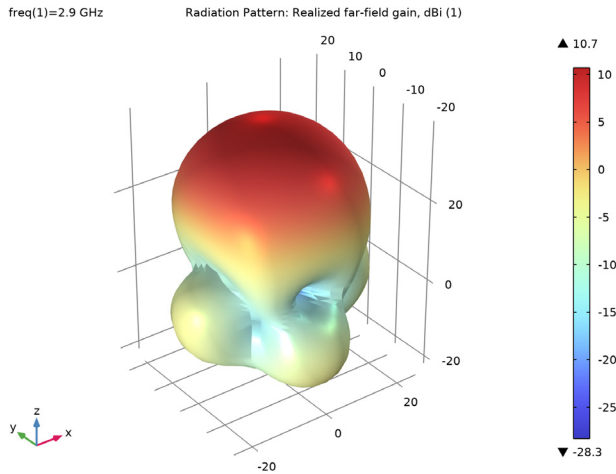

Figure 3: 3D far-field radiation pattern shows the directivity is increased by the dielectric resonator and the metallic strips.

---

**Application Library path:** RF\_Module/Antennas/dielectric\_resonator\_antenna

---

### *Modeling Instructions*



---

From the **File** menu, choose **New**.

#### **NEW**

In the **New** window, click  **Model Wizard**.

#### **MODEL WIZARD**

- 1 In the **Model Wizard** window, click  **3D**.
- 2 In the **Select Physics** tree, select **Radio Frequency>Electromagnetic Waves, Frequency Domain (emw)**.
- 3 Click **Add**.
- 4 Click  **Study**.
- 5 In the **Select Study** tree, select **General Studies>Frequency Domain**.
- 6 Click  **Done**.

#### **GLOBAL DEFINITIONS**

##### *Parameters 1*

- 1 In the **Model Builder** window, under **Global Definitions** click **Parameters 1**.
- 2 In the **Settings** window for **Parameters**, locate the **Parameters** section.

3 In the table, enter the following settings:

Name	Expression	Value	Description
thickness	20[mil]	5.08E-4 m	Substrate thickness
l_substrate	110[mm]	0.11 m	Length, substrate
w_line	1.13[mm]	0.00113 m	Width, feed line
l_line	40[mm]	0.04 m	Length, feed line
w_resonator	70[mm]	0.07 m	Width, dielectric resonator
l_resonator	25[mm]	0.025 m	Length, dielectric resonator
h_resonator	45[mm]	0.045 m	Height, dielectric resonator
w_matching	1.13[mm]	0.00113 m	Width, matching stub
l_matching	35.2[mm]	0.0352 m	Length, matching stub
w_slot	2.9[mm]	0.0029 m	Width, slot
l_slot	18.5[mm]	0.0185 m	Length, slot
d_array	30[mm]	0.03 m	Array displacement
f0	2.9[GHz]	2.9E9 Hz	Current frequency
lda0	c_const/f0	0.10338 m	Wavelength, air
h_max	0.2*lda0	0.020675 m	Maximum mesh element size, air

Here, mil refers to the unit milliinch. c\_const is a predefined COMSOL constant for the speed of light in vacuum.

## GEOMETRY I



First, create a block for the dielectric resonator.

### Dielectric resonator

- 1 In the **Geometry** toolbar, click  **Block**.
- 2 In the **Settings** window for **Block**, type Dielectric resonator in the **Label** text field.
- 3 Locate the **Size and Shape** section. In the **Width** text field, type w\_resonator.
- 4 In the **Depth** text field, type l\_resonator.
- 5 In the **Height** text field, type h\_resonator.
- 6 Locate the **Position** section. From the **Base** list, choose **Center**.
- 7 In the **z** text field, type h\_resonator/2.

Add a block for the substrate.

### *Substrate*

- 1 In the **Geometry** toolbar, click  **Block**.
- 2 In the **Settings** window for **Block**, type Substrate in the **Label** text field.
- 3 Locate the **Size and Shape** section. In the **Width** text field, type  $l\_substrate$ .
- 4 In the **Depth** text field, type  $l\_substrate$ .
- 5 In the **Height** text field, type thickness.
- 6 Locate the **Position** section. From the **Base** list, choose **Center**.
- 7 In the **z** text field, type  $-thickness/2$ .
- 8 Click the  **Wireframe Rendering** button in the **Graphics** toolbar.

Add a block for the microstrip feed line.

### *Feed line*

- 1 In the **Geometry** toolbar, click  **Block**.
- 2 In the **Settings** window for **Block**, type Feed line in the **Label** text field.
- 3 Locate the **Size and Shape** section. In the **Width** text field, type  $w\_line$ .
- 4 In the **Depth** text field, type  $l\_line$ .
- 5 In the **Height** text field, type thickness.
- 6 Locate the **Position** section. From the **Base** list, choose **Center**.
- 7 In the **y** text field, type  $-l\_line/2$ .
- 8 In the **z** text field, type  $-thickness/2$ .

Add a block for the matching stub which is extended from the end of the feed line.

### *Matching stub*

- 1 In the **Geometry** toolbar, click  **Block**.
- 2 In the **Settings** window for **Block**, type Matching stub in the **Label** text field.
- 3 Locate the **Size and Shape** section. In the **Width** text field, type  $w\_matching$ .
- 4 In the **Depth** text field, type  $l\_matching$ .
- 5 In the **Height** text field, type thickness.
- 6 Locate the **Position** section. From the **Base** list, choose **Center**.
- 7 In the **y** text field, type  $l\_matching/2$ .
- 8 In the **z** text field, type  $-thickness/2$ .

9 Click  **Build Selected.**

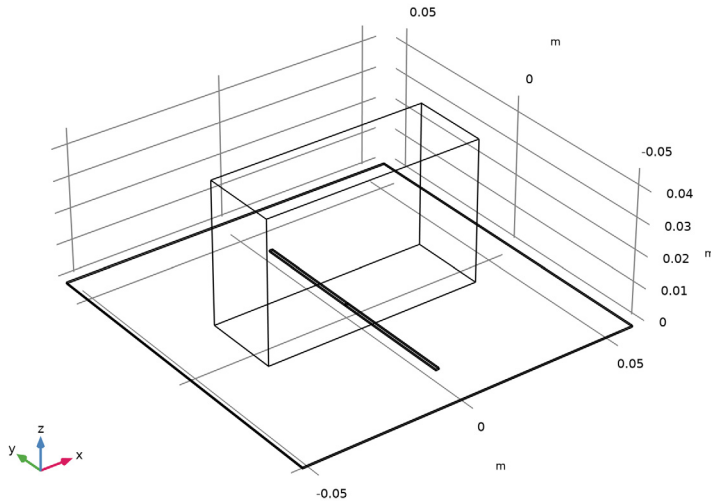

Then, add a work plane for the slot. The slot is located between the dielectric resonator and substrate.

*Work Plane 1 (wp1)*



- 1 In the **Geometry** toolbar, click  **Work Plane.**
- 2 In the **Settings** window for **Work Plane**, click  **Show Work Plane.**

*Work Plane 1 (wp1)>Plane Geometry*

In the **Model Builder** window, click **Plane Geometry.**

Create a rectangle for the slot.

*Work Plane 1 (wp1)>Rectangle 1 (r1)*

- 1 In the **Work Plane** toolbar, click  **Rectangle.**
- 2 Click the  **Zoom Extents** button in the **Graphics** toolbar.
- 3 In the **Settings** window for **Rectangle**, locate the **Size and Shape** section.
- 4 In the **Width** text field, type `l_slot`.
- 5 In the **Height** text field, type `w_slot`.
- 6 Locate the **Position** section. From the **Base** list, choose **Center.**



7 Click  **Build Selected.**

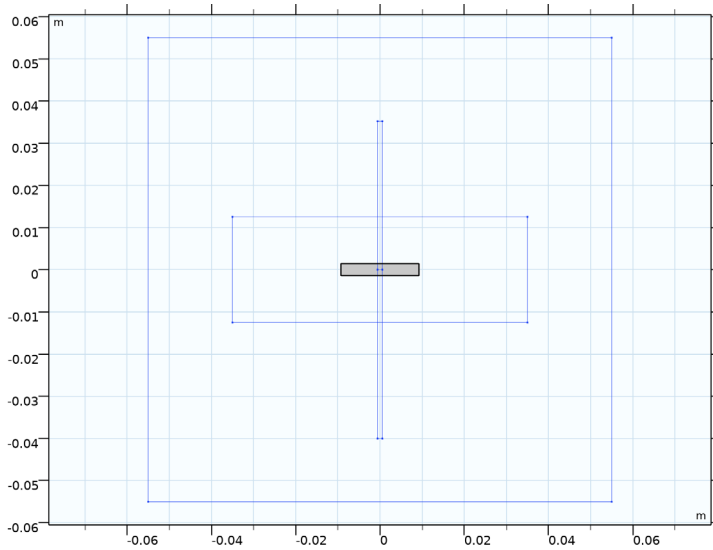

Add a work plane on one of the side walls of the dielectric resonator. You may click Close in the current Work Plane toolbar to access the Geometry toolbar.

*Work Plane 2 (wp2)*

- 1 In the **Model Builder** window, right-click **Geometry 1** and choose **Work Plane**.
- 2 In the **Settings** window for **Work Plane**, locate the **Plane Definition** section.
- 3 From the **Plane type** list, choose **Face parallel**.

4 On the object **blk1**, select Boundary 3 only.

It might be easier to select the correct boundary by using the **Selection List** window. To open this window, in the **Home** toolbar click **Windows** and choose **Selection List**. (If you are running the cross-platform desktop, you find **Windows** in the main menu.)

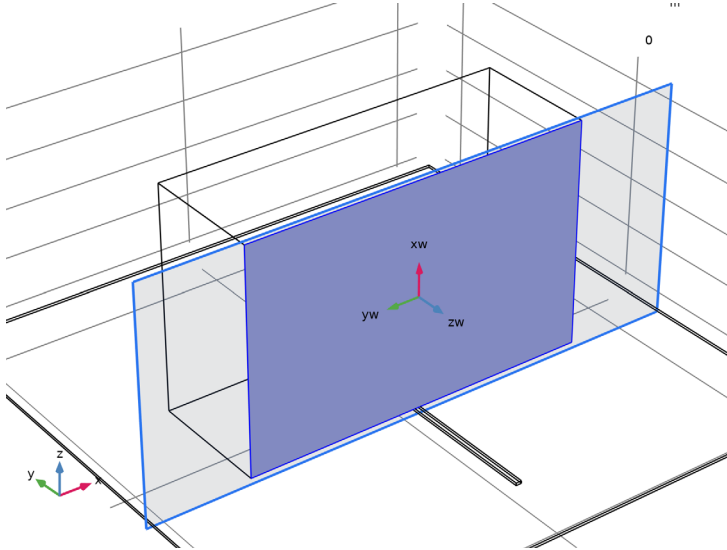

5 Click  **Show Work Plane**.

*Work Plane 2 (wp2)>Plane Geometry*  
Create a circle for the ring strip.

*Work Plane 2 (wp2)>Circle 1 (c1)*

1 In the **Work Plane** toolbar, click  **Circle**.

2 Click the  **Zoom Extents** button in the **Graphics** toolbar.

3 In the **Settings** window for **Circle**, locate the **Size and Shape** section.

4 In the **Radius** text field, type 16.8 [mm].

5 Click to expand the **Layers** section. In the table, enter the following settings:

Layer name	Thickness (m)
Layer 2	1 [mm]

*Copy 1 (copy1)*

1 Right-click **Geometry 1** and choose **Transforms>Copy**.

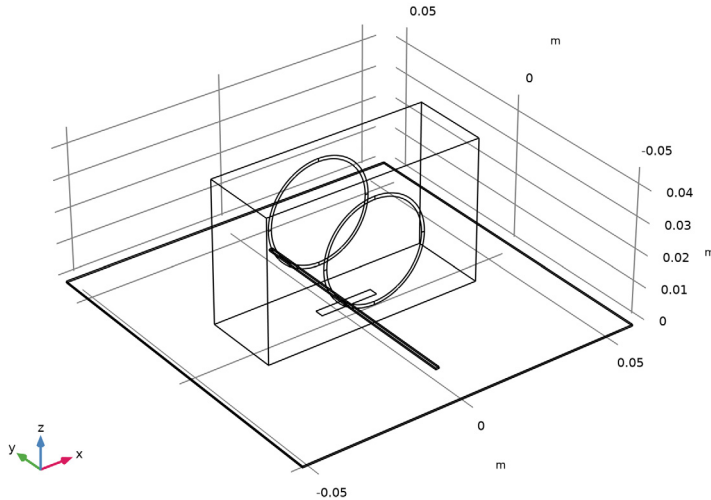

You may click Close in the current Work Plane toolbar to access the Geometry toolbar.

- 2 Select the object **wp2** only.
- 3 In the **Settings** window for **Copy**, locate the **Displacement** section.
- 4 In the **y** text field, type **1\_resonator**.
- 5 Click  **Build Selected**.



Add a work plane on the top of the dielectric resonator.



*Work Plane 3 (wp3)*

- 1 In the **Geometry** toolbar, click  **Work Plane**.
- 2 In the **Settings** window for **Work Plane**, locate the **Plane Definition** section.
- 3 From the **Plane type** list, choose **Face parallel**.
- 4 On the object **blk1**, select Boundary 4 only.
- 5 Click  **Show Work Plane**.

*Work Plane 3 (wp3)>Plane Geometry*



Create a rectangle for the short strip.

*Work Plane 3 (wp3)>Rectangle 1 (r1)*

- 1 In the **Work Plane** toolbar, click  **Rectangle**.
- 2 Click the  **Zoom Extents** button in the **Graphics** toolbar.
- 3 In the **Settings** window for **Rectangle**, locate the **Size and Shape** section.
- 4 In the **Width** text field, type **2[mm]**.

- 5 In the **Height** text field, type `l_resonator`.
- 6 Locate the **Position** section. From the **Base** list, choose **Center**.
- 7 In the **xw** text field, type `-d_array/2`.

*Work Plane 3 (wp3)>Array 1 (arr1)*

- 1 In the **Work Plane** toolbar, click  **Transforms** and choose **Array**.
- 2 Select the object **r1** only.
- 3 In the **Settings** window for **Array**, locate the **Size** section.
- 4 In the **xw size** text field, type `2`.
- 5 Locate the **Displacement** section. In the **xw** text field, type `d_array`.
- 6 Click  **Build Selected**.

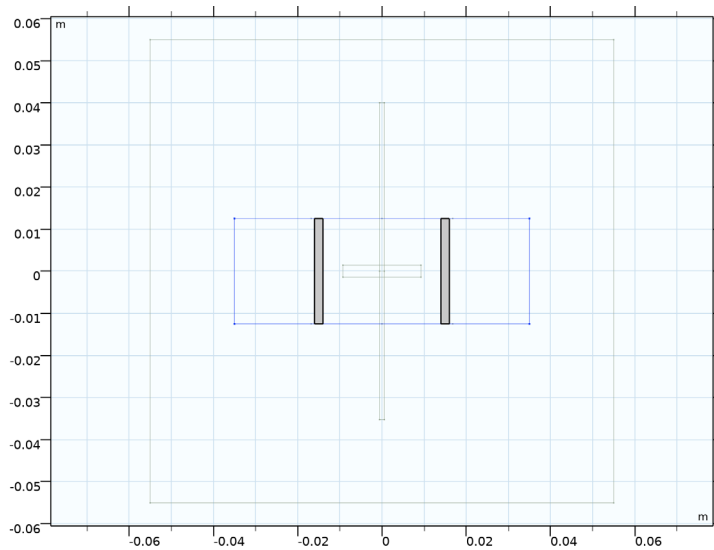

Finish geometry creation by adding a sphere for the PMLs.

*PMLs*

- 1 Right-click **Geometry 1** and choose **Sphere**.
- 2 In the **Settings** window for **Sphere**, type `PMLs` in the **Label** text field.
- 3 Locate the **Size** section. In the **Radius** text field, type `0.11`.

4 Click to expand the **Layers** section. In the table, enter the following settings:

Layer name	Thickness (m)
Layer 1	0.02

5 Click  **Build All Objects**.

6 Click the  **Zoom Out** button in the **Graphics** toolbar.

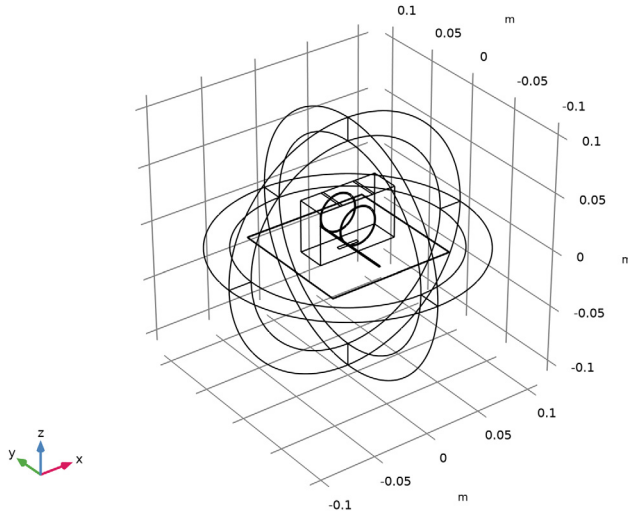

The finished geometry describes the dielectric resonator antenna on a thin substrate enclosed by PMLs.

## DEFINITIONS

*Perfectly Matched Layer 1 (pml1)*

1 In the **Definitions** toolbar, click  **Perfectly Matched Layer**.

2 Select Domains 1–4 and 10–13 only.

3 In the **Settings** window for **Perfectly Matched Layer**, locate the **Geometry** section.

4 From the **Type** list, choose **Spherical**.

Create a set of selections for use before setting up the physics. First, create a selection for the substrate.

*Substrate*

1 In the **Definitions** toolbar, click  **Explicit**.

- 2 In the **Settings** window for **Explicit**, type Substrate in the **Label** text field.
- 3 Select Domains 6, 8, and 9 only.

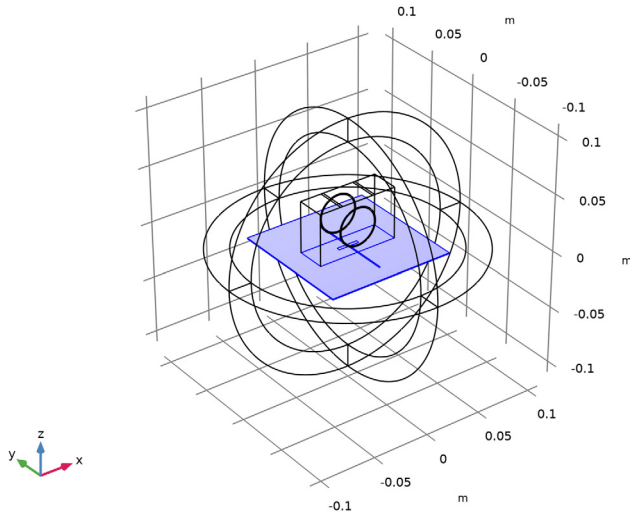

Add selections for the dielectric resonator, microstrip line, ground plane, and metal strips.

#### *Dielectric resonator*

- 1 In the **Definitions** toolbar, click  **Explicit**.
- 2 In the **Settings** window for **Explicit**, type Dielectric resonator in the **Label** text field.

3 Select Domain 7 only.

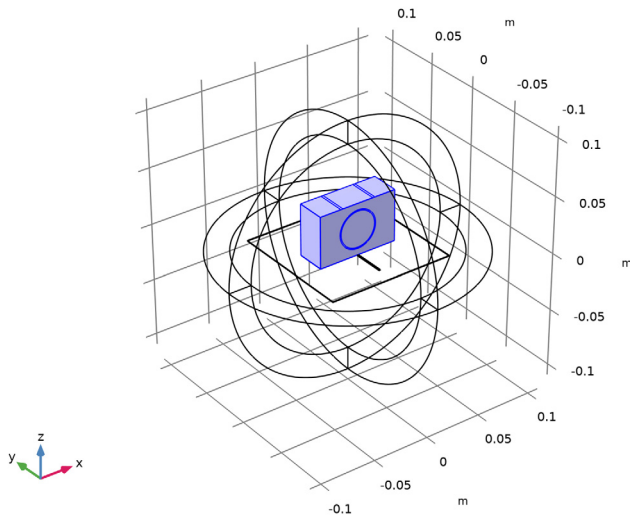

#### *Microstrip line*

- 1 In the **Definitions** toolbar, click  **Explicit**.
- 2 In the **Settings** window for **Explicit**, type Microstrip line in the **Label** text field.
- 3 Locate the **Input Entities** section. From the **Geometric entity level** list, choose **Boundary**.

4 Select Boundaries 34 and 40 only.

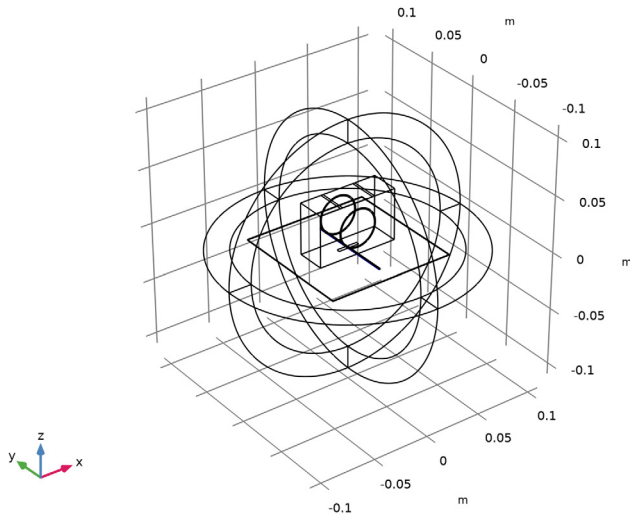

#### Ground plane

- 1 In the **Definitions** toolbar, click  **Explicit**.
- 2 In the **Settings** window for **Explicit**, type Ground plane in the **Label** text field.
- 3 Locate the **Input Entities** section. From the **Geometric entity level** list, choose **Boundary**.



4 Select Boundaries 16, 20, 35, 36, 42, 43, and 66 only.

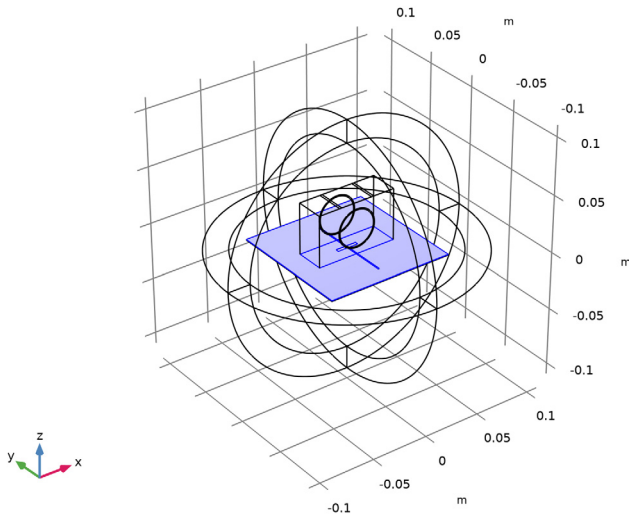

#### *Metal strips*

- 1 In the **Definitions** toolbar, click  **Explicit**.
- 2 In the **Settings** window for **Explicit**, type Metal strips in the **Label** text field.
- 3 Locate the **Input Entities** section. From the **Geometric entity level** list, choose **Boundary**.

4 Select Boundaries 23–27, 52, 53, 62, 63, and 69 only.

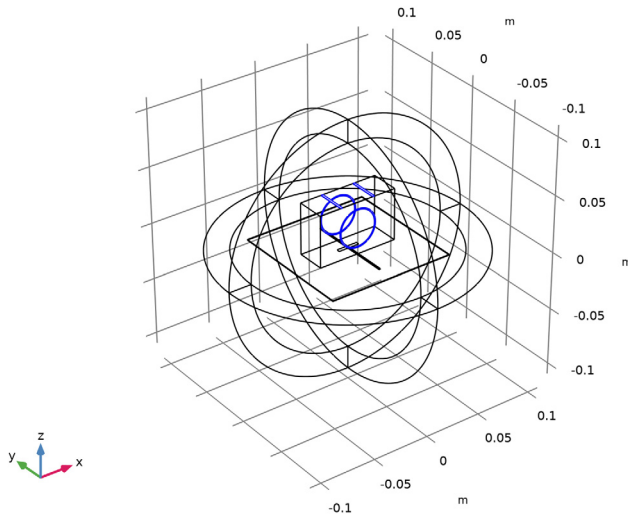

5 Click the  **Zoom Extents** button in the **Graphics** toolbar.

To get a better view, suppress some of the boundaries. Furthermore, by assigning the resulting settings to a View node, you can easily return to the same view later by clicking the **Go to View 5** button in the **Graphics** toolbar.

*View 5*

- 1 In the **Definitions** toolbar, click  **View**.
- 2 Click the  **Wireframe Rendering** button in the **Graphics** toolbar.

*Hide for Physics 1*

- 1 Right-click **View 5** and choose **Hide for Physics**.
- 2 In the **Settings** window for **Hide for Physics**, click  **Show Entities in Selection**.

3 Select Domains 2, 5, and 11 only.

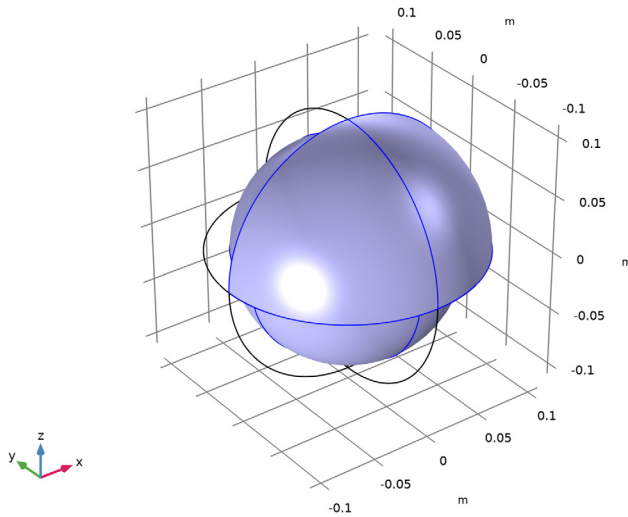

## ELECTROMAGNETIC WAVES, FREQUENCY DOMAIN (EMW)

### *Perfect Electric Conductor 2*

- 1 In the **Model Builder** window, under **Component 1 (comp1)** right-click **Electromagnetic Waves, Frequency Domain (emw)** and choose **Perfect Electric Conductor**.
- 2 In the **Settings** window for **Perfect Electric Conductor**, locate the **Boundary Selection** section.
- 3 From the **Selection** list, choose **Microstrip line**.



### *Perfect Electric Conductor 3*

- 1 In the **Physics** toolbar, click  **Boundaries** and choose **Perfect Electric Conductor**.
- 2 In the **Settings** window for **Perfect Electric Conductor**, locate the **Boundary Selection** section.
- 3 From the **Selection** list, choose **Ground plane**.

### *Perfect Electric Conductor 4*

- 1 In the **Physics** toolbar, click  **Boundaries** and choose **Perfect Electric Conductor**.
- 2 In the **Settings** window for **Perfect Electric Conductor**, locate the **Boundary Selection** section.
- 3 From the **Selection** list, choose **Metal strips**.

### Lumped Port 1

- 1 In the **Physics** toolbar, click  **Boundaries** and choose **Lumped Port**.
- 2 Click the  **Zoom In** button in the **Graphics** toolbar, a couple of times to see the port boundary clearly.
- 3 Select Boundary 33 only.

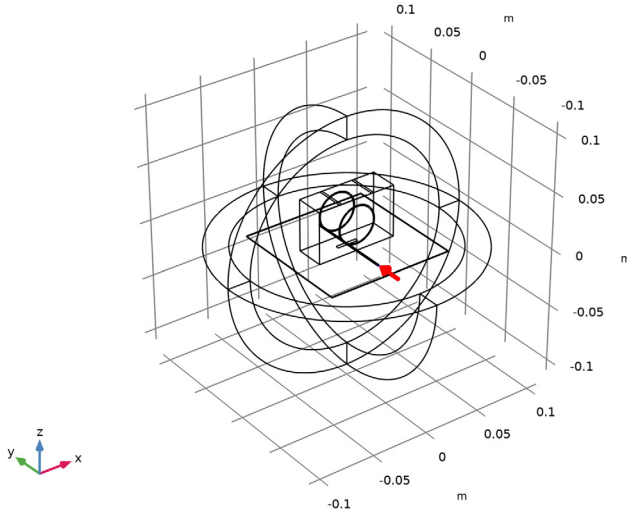

For the first port, wave excitation is **on** by default.

- 4 Click the  **Zoom Extents** button in the **Graphics** toolbar.

### Far-Field Domain 1

In the **Physics** toolbar, click  **Domains** and choose **Far-Field Domain**.

## MATERIALS

Next, assign material properties on the model. Begin by specifying air for all domains.

### ADD MATERIAL

- 1 In the **Home** toolbar, click  **Add Material** to open the **Add Material** window.
- 2 Go to the **Add Material** window.
- 3 In the tree, select **Built-in>Air**.
- 4 Click **Add to Component** in the window toolbar.

## MATERIALS

Override the substrate with the dielectric material of  $\epsilon_r = 3.38$ .

### Substrate

- 1 In the **Model Builder** window, under **Component 1 (comp1)** right-click **Materials** and choose **Blank Material**.
- 2 In the **Settings** window for **Material**, type Substrate in the **Label** text field.
- 3 Locate the **Geometric Entity Selection** section. From the **Selection** list, choose **Substrate**.
- 4 Locate the **Material Contents** section. In the table, enter the following settings:

Property	Variable	Value	Unit	Property group
Relative permittivity	epsilon <sub>nr_iso</sub> ; epsilon <sub>nr<sub>ii</sub></sub> = epsilon <sub>nr_iso</sub> , epsilon <sub>nr<sub>ij</sub></sub> = 0	3.38		Basic
Relative permeability	mu <sub>r_iso</sub> ; mu <sub>r<sub>ii</sub></sub> = mu <sub>r_iso</sub> , mu <sub>r<sub>ij</sub></sub> = 0	1		Basic
Electrical conductivity	sigma <sub>iso</sub> ; sigma <sub>ii</sub> = sigma <sub>iso</sub> , sigma <sub>ij</sub> = 0	0	S/m	Basic

Override the dielectric resonator with the quartz.

## ADD MATERIAL

- 1 Go to the **Add Material** window.
- 2 In the tree, select **AC/DC>Quartz**.
- 3 Click **Add to Component** in the window toolbar.
- 4 In the **Home** toolbar, click  **Add Material** to close the **Add Material** window.

## MATERIALS

### Quartz (mat3)

- 1 In the **Settings** window for **Material**, locate the **Geometric Entity Selection** section.
- 2 From the **Selection** list, choose **Dielectric resonator**.

## MESH 1

Choose the maximum mesh size in the air domain smaller than 0.2 wavelengths using the parameter  $h_{\max}$  that you defined earlier. For the dielectric materials, scale the mesh size by the inverse of the square root of the relative dielectric constant.

### Size 1

- 1 In the **Model Builder** window, under **Component 1 (comp1)** right-click **Mesh 1** and choose **Size**.
- 2 In the **Settings** window for **Size**, locate the **Geometric Entity Selection** section.
- 3 From the **Geometric entity level** list, choose **Domain**.
- 4 Click  **Paste Selection**.
- 5 In the **Paste Selection** dialog box, type 5 in the **Selection** text field.
- 6 Click **OK**.
- 7 In the **Settings** window for **Size**, locate the **Element Size** section.
- 8 Click the **Custom** button.
- 9 Locate the **Element Size Parameters** section. Select the **Maximum element size** check box.
- 10 In the associated text field, type  $h_{\max}$ .



### Size 2

- 1 In the **Model Builder** window, right-click **Mesh 1** and choose **Size**.
- 2 In the **Settings** window for **Size**, locate the **Geometric Entity Selection** section.
- 3 From the **Geometric entity level** list, choose **Domain**.
- 4 From the **Selection** list, choose **Substrate**.
- 5 Locate the **Element Size** section. Click the **Custom** button.
- 6 Locate the **Element Size Parameters** section. Select the **Maximum element size** check box.
- 7 In the associated text field, type  $h_{\max}/\sqrt{3.38}$ .

### Size 3

- 1 Right-click **Mesh 1** and choose **Size**.
- 2 In the **Settings** window for **Size**, locate the **Geometric Entity Selection** section.
- 3 From the **Geometric entity level** list, choose **Domain**.
- 4 From the **Selection** list, choose **Dielectric resonator**.
- 5 Locate the **Element Size** section. Click the **Custom** button.
- 6 Locate the **Element Size Parameters** section. Select the **Maximum element size** check box.
- 7 In the associated text field, type  $h_{\max}/\sqrt{4.2}$ .

### Free Tetrahedral I

- 1 In the **Mesh** toolbar, click  **Free Tetrahedral**.
- 2 In the **Settings** window for **Free Tetrahedral**, locate the **Domain Selection** section.
- 3 From the **Geometric entity level** list, choose **Domain**.
- 4 Click  **Paste Selection**.
- 5 In the **Paste Selection** dialog box, type 5-9 in the **Selection** text field.
- 6 Click **OK**.

Use a swept mesh for the PMLs.



### Swept I

In the **Mesh** toolbar, click  **Swept**.

### Distribution I

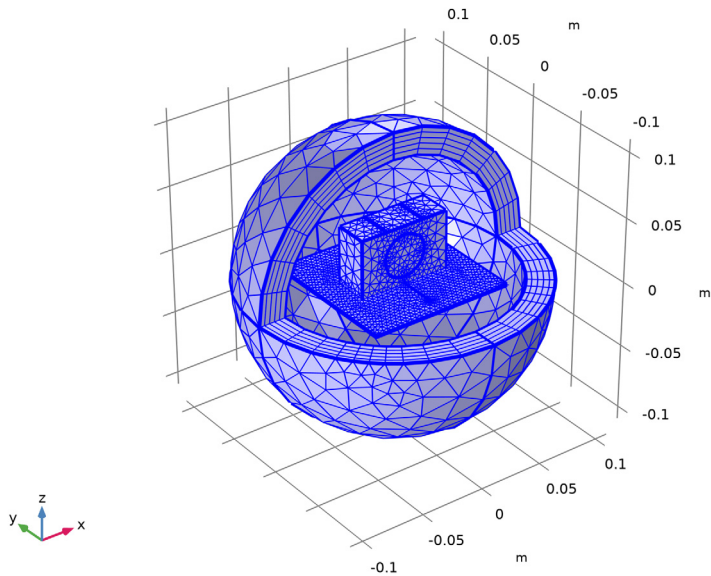
- 1 Right-click **Swept I** and choose **Distribution**.
- 2 Right-click **Distribution I** and choose **Build All**.



- 3 In the **Settings** window for **Distribution**, in the **Graphics** window toolbar, click  next to  **Go to Default View**, then choose **Go to View I**, to reset the visibility state of the hidden domains in preparation of the results processing.

## STUDY 1

### *Step 1: Frequency Domain*

- 1 In the **Model Builder** window, under **Study 1** click **Step 1: Frequency Domain**.
- 2 In the **Settings** window for **Frequency Domain**, locate the **Study Settings** section.
- 3 In the **Frequencies** text field, type  $f_0$ .
- 4 In the **Home** toolbar, click  **Compute**.

Adjust settings to see the E-field norm as a dB scale.

## RESULTS

### *Electric Field (emw)*

- 1 In the **Model Builder** window, under **Results** click **Electric Field (emw)**.
- 2 In the **Settings** window for **3D Plot Group**, locate the **Plot Settings** section.
- 3 Clear the **Plot dataset edges** check box.

### *Surface 1*

Right-click **Electric Field (emw)** and choose **Surface**.

### *Selection 1*

- 1 In the **Model Builder** window, right-click **Surface 1** and choose **Selection**.
- 2 In the **Settings** window for **Selection**, locate the **Selection** section.
- 3 Click  **Paste Selection**.
- 4 In the **Paste Selection** dialog box, type 13-44, 52, 53, 62, 63, 65-72 in the **Selection** text field.
- 5 Click **OK**.

### *Surface 1*

- 1 In the **Model Builder** window, click **Surface 1**.
- 2 In the **Settings** window for **Surface**, locate the **Expression** section.
- 3 In the **Expression** text field, type  $20 \cdot \log_{10}(\text{emw.normE})$ .
- 4 In the **Electric Field (emw)** toolbar, click  **Plot**.
- 5 Locate the **Coloring and Style** section. From the **Color table** list, choose **HeatCameraLight**.
- 6 From the **Color table transformation** list, choose **None**.



### *Multislice*

- 1 In the **Model Builder** window, click **Multislice**.



- 2 In the **Settings** window for **Multislice**, locate the **Multiplane Data** section.
- 3 Find the **Z-planes** subsection. In the **Planes** text field, type 0.
- 4 Locate the **Expression** section. In the **Expression** text field, type  $20 \cdot \log_{10}(\text{emw}.\text{normE})$ .

### Transparency I

- 1 Right-click **Multislice** and choose **Transparency**.
- 2 In the **Electric Field (emw)** toolbar, click  **Plot**.
- 3 Click the  **Zoom In** button in the **Graphics** toolbar.

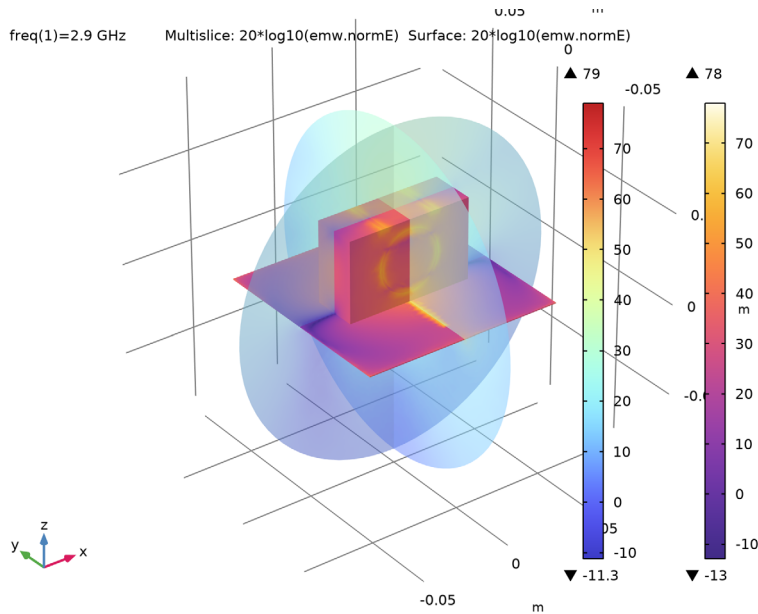

### Radiation Pattern I

- 1 In the **Model Builder** window, expand the **Results>2D Far Field (emw)** node, then click **Radiation Pattern 1**.
- 2 In the **Settings** window for **Radiation Pattern**, locate the **Evaluation** section.
- 3 Find the **Angles** subsection. In the **Number of angles** text field, type 100.
- 4 Find the **Reference direction** subsection. In the **x** text field, type 0.
- 5 In the **y** text field, type 1.
- 6 Find the **Normal vector** subsection. In the **x** text field, type 1.
- 7 In the **z** text field, type 0.
- 8 Click to expand the **Legends** section. From the **Legends** list, choose **Manual**.

9 In the table, enter the following settings:

---

**Legends**

E-plane

10 In the **2D Far Field (emw)** toolbar, click  **Plot**.

*Radiation Pattern 2*

1 Right-click **Results>2D Far Field (emw)>Radiation Pattern 1** and choose **Duplicate**.

2 In the **Settings** window for **Radiation Pattern**, locate the **Evaluation** section.

3 Find the **Reference direction** subsection. In the **x** text field, type 1.

4 In the **y** text field, type 0.

5 Find the **Normal vector** subsection. In the **x** text field, type 0.

6 In the **y** text field, type -1.

7 Locate the **Legends** section. In the table, enter the following settings:

---

**Legends**

H-plane

8 In the **2D Far Field (emw)** toolbar, click  **Plot**.

This is the far-field radiation patterns on the E-plane and H-plane ([Figure 2](#)).

*3D Far Field, Gain (emw)*

Compare the 3D far-field radiation pattern plot with [Figure 3](#).

Inspect the input matching property ( $S_{11}$ ) at the simulated frequency.