



Shape Optimization of a Shell

Introduction

Shape optimization can be used to alter the geometry of an existing product to improve its performance. You can do that using the Deformed Geometry interface, but you have to decide which shape deformations to allow. It is important to impose some restriction to preserve the mesh quality during the optimization. One approach is to use a Helmholtz filter to introduce a length scale, which (in combination with a maximum displacement parameter) limits the slope of the shape variations. This type of regularized shape optimization can be setup using equation based modeling, but it is also built into the **Free Shape Shell** feature. This feature differs from the **Free Shape Boundary** feature in that it can be used on boundaries that are not adjacent to meshed domains.

Model Definition

Shape optimization is often subject to constraints on the geometry deformation, and this model shows how the **Free Shape Shell** feature can be combined with the **Free Shape Symmetry** features to restrict one the edges to move along an imaginary boundary defined by a normal vector. All the other external edges of the shell are fixed using the **Fixed Edge** feature. The initial geometry of the shell is shown in [Figure 1](#).

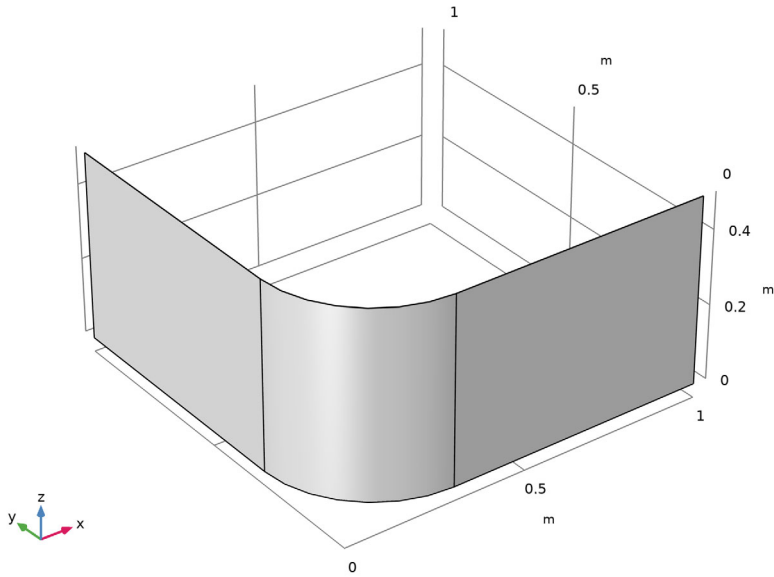

Figure 1: The initial geometry is shown. The load is applied in the y-direction on the rightmost edge, while the displacement and rotation is fixed at the leftmost edge of the shell. The shape deformation of this edge is restricted to the xz -plane.

The shell is made of steel and the objective is to maximize its stiffness by deforming it. An initial study is performed to determine a characteristic value for the area and the total elastic strain energy.

The model uses geometric nonlinearity, because the applied load is so large that this is warranted.

Results and Discussion

The optimal design is intuitive in the sense that it deforms the shell, so that material is moved away from the midplane, increasing the stiffness of the shell, see [Figure 2](#).

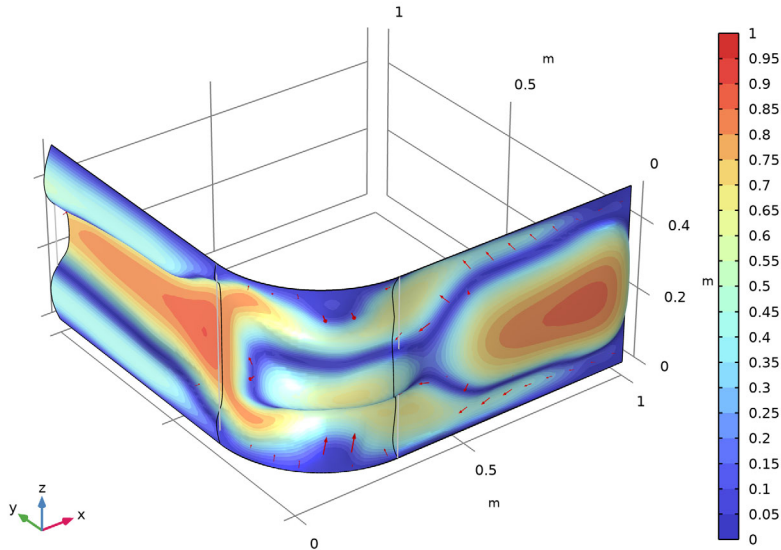

Figure 2: The default shape optimization plot shows the edges of the old geometry in gray together with a surface plot of the relative normal boundary displacement in colors. The actual displacement is shown with red arrows.

By deforming the shell, the optimization is able to reduce the elastic strain energy by 89%. This causes an 9% increase in the surface area.

Notes About the COMSOL Implementation

This model combines the Optimization and Shell interfaces. The shape optimization features are added before the first study is computed, because this automatically sets the correct scales for the shape optimization variables. It is possible to add the shape optimization features after the first study has been computed, but then the first study will no longer converge (the shape optimization variables cannot be disabled).

Application Library path: Optimization_Module/Shape_Optimization/
shell_shape_optimization



Modeling Instructions

From the **File** menu, choose **New**.

NEW

In the **New** window, click  **Model Wizard**.

MODEL WIZARD

- 1 In the **Model Wizard** window, click  **3D**.
- 2 In the **Select Physics** tree, select **Structural Mechanics>Shell (shell)**.
- 3 Click **Add**.
- 4 Click  **Study**.
- 5 In the **Select Study** tree, select **General Studies>Stationary**.
- 6 Click  **Done**.

GLOBAL DEFINITIONS

Parameters 1

- 1 In the **Model Builder** window, under **Global Definitions** click **Parameters 1**.
- 2 In the **Settings** window for **Parameters**, locate the **Parameters** section.
- 3 In the table, enter the following settings:

Name	Expression	Value	Description
Lmax	5[cm]	0.05 m	Maximum displacement
Fload	10[kN]	10000 N	Load

GEOMETRY 1

Work Plane 1 (wp1)

In the **Geometry** toolbar, click  **Work Plane**.

Work Plane 1 (wp1)>Plane Geometry

In the **Model Builder** window, click **Plane Geometry**.

Work Plane 1 (wp1)>Square 1 (sq1)

In the **Work Plane** toolbar, click  **Square**.

Work Plane 1 (wp1)>Fillet 1 (fil1)

1 In the **Work Plane** toolbar, click  **Fillet**.

2 On the object **sq1**, select Point 1 only.

3 In the **Settings** window for **Fillet**, locate the **Radius** section.

4 In the **Radius** text field, type 0.3.

Work Plane 1 (wp1)>Convert to Curve 1 (ccurl)

1 In the **Work Plane** toolbar, click  **Conversions** and choose **Convert to Curve**.

2 Select the object **fil1** only.

Edges to Delete

1 In the **Work Plane** toolbar, click  **Selections** and choose **Box Selection**.

2 In the **Settings** window for **Box Selection**, type Edges to Delete in the **Label** text field.

3 Locate the **Geometric Entity Level** section. From the **Level** list, choose **Boundary**.

4 Locate the **Box Limits** section. In the **xw minimum** text field, type 0.9.

5 In the **yw minimum** text field, type 0.9.

Work Plane 1 (wp1)>Delete Entities 1 (dell)

1 Right-click **Plane Geometry** and choose **Delete Entities**.

2 In the **Settings** window for **Delete Entities**, locate the **Entities or Objects to Delete** section.

3 From the **Selection** list, choose **Edges to Delete**.

Extrude 1 (ext1)

1 In the **Model Builder** window, right-click **Geometry 1** and choose **Extrude**.

2 In the **Settings** window for **Extrude**, locate the **Distances** section.

3 In the table, enter the following settings:

Distances (m)
0.5



4 Locate the **Selections of Resulting Entities** section. Select the **Resulting objects selection** check box.

5 From the **Show in physics** list, choose **Boundary selection**.



6 In the **Geometry** toolbar, click  **Build All**.

The geometry should now look like that in [Figure 1](#).

Exterior Edges

- 1 In the **Geometry** toolbar, click  **Selections** and choose **Adjacent Selection**.
- 2 In the **Settings** window for **Adjacent Selection**, type Exterior Edges in the **Label** text field.
- 3 Locate the **Input Entities** section. From the **Geometric entity level** list, choose **Boundary**.
- 4 Locate the **Output Entities** section. From the **Geometric entity level** list, choose **Adjacent edges**.
- 5 Locate the **Input Entities** section. Click  **Add**.
- 6 In the **Add** dialog box, select **Extrude 1** in the **Input selections** list.
- 7 Click **OK**.
- 8 In the **Geometry** toolbar, click  **Build All**.
The model geometry is now complete.

ADD MATERIAL

- 1 In the **Home** toolbar, click  **Add Material** to open the **Add Material** window.
- 2 Go to the **Add Material** window.
- 3 In the tree, select **Built-in>Structural steel**.
- 4 Click **Add to Component** in the window toolbar.
- 5 In the **Home** toolbar, click  **Add Material** to close the **Add Material** window.

MESH 1

Mapped 1

- 1 In the **Mesh** toolbar, click  **Boundary** and choose **Mapped**.
- 2 In the **Settings** window for **Mapped**, locate the **Boundary Selection** section.
- 3 From the **Selection** list, choose **All boundaries**.

Size

- 1 In the **Model Builder** window, click **Size**.
- 2 In the **Settings** window for **Size**, locate the **Element Size** section.
- 3 From the **Predefined** list, choose **Finer**.
- 4 Click to expand the **Element Size Parameters** section. In the **Maximum element size** text field, type L_{max} .
- 5 In the **Minimum element size** text field, type $L_{max}/2$.
- 6 Click  **Build All**.

SHELL (SHELL)

Enable weak normal constraints to get the correct gradient from the sensitivity analysis performed during the optimization.

- 1 Click the  **Show More Options** button in the **Model Builder** toolbar.
- 2 In the **Show More Options** dialog box, select **Physics>Advanced Physics Options** in the tree.
- 3 In the tree, select the check box for the node **Physics>Advanced Physics Options**.
- 4 Click **OK**.
- 5 In the **Model Builder** window, under **Component 1 (comp1)** click **Shell (shell)**.
- 6 In the **Settings** window for **Shell**, click to expand the **Advanced Settings** section.
- 7 Select the **Use weak constraints for shell normals** check box.

Fixed Constraint 1

- 1 In the **Physics** toolbar, click  **Edges** and choose **Fixed Constraint**.
- 2 Select Edge 6 only.
- 3 In the **Settings** window for **Fixed Constraint**, click to expand the **Constraint Settings** section.
- 4 Select the **Use weak constraints** check box.

Edge Load 1

- 1 In the **Physics** toolbar, click  **Edges** and choose **Edge Load**.
- 2 Select Edge 10 only.
- 3 In the **Settings** window for **Edge Load**, locate the **Force** section.
- 4 From the **Load type** list, choose **Total force**.
- 5 Specify the \mathbf{F}_{tot} vector as

0	x
-Fload	y
0	z

COMPONENT 1 (COMPI)

Define the shape optimization problem using the **Free Shape Shell**, **Symmetry/Roller** and **Fixed Edge** features.

- 1 In the **Definitions** toolbar, click  **Optimization** and choose **Shape Optimization>Free Shape Shell**.

SHAPE OPTIMIZATION

Free Shape Shell 1

- 1 In the **Settings** window for **Free Shape Shell**, locate the **Boundary Selection** section.
- 2 From the **Selection** list, choose **All boundaries**.
- 3 Locate the **Control Variable Settings** section. In the d_{\max} text field, type L_{\max} .
- 4 Locate the **Filtering** section. From the R_{\min} list, choose **Small**.

Fixed Edge 1

- 1 In the **Definitions** toolbar, click  **Optimization** and choose **Shape Optimization > Fixed Edge**.
- 2 In the **Settings** window for **Fixed Edge**, locate the **Edge Selection** section.
- 3 From the **Selection** list, choose **Exterior Edges**.

Symmetry/Roller 1

- 1 In the **Definitions** toolbar, click  **Optimization** and choose **Shape Optimization > Symmetry/Roller**.
- 2 In the **Settings** window for **Symmetry/Roller**, locate the **Geometric Entity Selection** section.
- 3 From the **Geometric entity level** list, choose **Edge**.
- 4 Select Edge 6 only.
- 5 Locate the **Prescribed Normal Vector** section. Specify the \mathbf{n} vector as

0	X
1	Y
0	Z

STUDY 1

Step 1: Stationary

- 1 In the **Model Builder** window, under **Study 1** click **Step 1: Stationary**.
- 2 In the **Settings** window for **Stationary**, locate the **Study Settings** section.
- 3 Select the **Include geometric nonlinearity** check box.

The initial design has low stiffness, so the problem becomes highly nonlinear. Use continuation in the load to make a continuous transition from the linear regime.
- 4 Click to expand the **Study Extensions** section. Select the **Auxiliary sweep** check box.
- 5 Click  **Add**.

6 In the table, enter the following settings:

Parameter name	Parameter value list	Parameter unit
Fload (Load)	0.1 10	kN

7 In the **Model Builder** window, click **Study 1**.

8 In the **Settings** window for **Study**, type **Initial Design** in the **Label** text field.

9 In the **Home** toolbar, click  **Compute**.

RESULTS

Shape Optimization

In the **Model Builder** window, under **Results** right-click **Shape Optimization** and choose **Delete**.

ADD STUDY

1 In the **Home** toolbar, click  **Add Study** to open the **Add Study** window.

2 Go to the **Add Study** window.

3 Find the **Studies** subsection. In the **Select Study** tree, select **General Studies>Stationary**.

4 Click **Add Study** in the window toolbar.

5 In the **Home** toolbar, click  **Add Study** to close the **Add Study** window.

INITIAL DESIGN

Step 1: Stationary

1 In the **Model Builder** window, under **Initial Design** click **Step 1: Stationary**.

2 In the **Settings** window for **Stationary**, locate the **Physics and Variables Selection** section.

3 In the table, clear the **Solve for** check box for **Shape Optimization (Component 1)**.

STUDY 2

Step 1: Stationary

1 In the **Model Builder** window, under **Study 2** click **Step 1: Stationary**.

2 In the **Settings** window for **Stationary**, locate the **Study Settings** section.

3 Select the **Include geometric nonlinearity** check box.

4 Click to expand the **Study Extensions** section. Select the **Auxiliary sweep** check box.

5 Click  **Add**.

6 In the table, enter the following settings:

Parameter name	Parameter value list	Parameter unit
Fload (Load)	0.1 10	kN

7 In the **Model Builder** window, click **Study 2**.

8 In the **Settings** window for **Study**, type Shape Optimization in the **Label** text field.

Shape Optimization

1 In the **Study** toolbar, click  **Optimization** and choose **Shape Optimization**.

2 In the **Settings** window for **Shape Optimization**, locate the **Optimization Solver** section.

3 Clear the **Move limits** check box.

4 In the **Maximum number of iterations** text field, type 25.

5 Click **Add Expression** in the upper-right corner of the **Objective Function** section. From the menu, choose **Component 1 (comp1)>Shell>Global>comp1.shell.Ws_tot - Total elastic strain energy - J**.

Scale the objective with the initial value.

6 Locate the **Objective Function** section. From the **Solution** list, choose **Use last**.

7 From the **Objective scaling** list, choose **Initial solution based**.

8 In the **Study** toolbar, click  **Get Initial Value**.

Solver Configurations

In the **Model Builder** window, expand the **Shape Optimization>Solver Configurations** node.

Solution 2 (sol2)

1 In the **Model Builder** window, expand the **Shape Optimization>Solver Configurations>Solution 2 (sol2)>Optimization Solver 1>Stationary 1>Segregated 1** node.

2 Right-click **Optimization** and choose **Move Up** to reduce the computational time.

3 In the **Model Builder** window, click **Merged variables**.

4 In the **Settings** window for **Segregated Step**, click to expand the **Method and Termination** section.

5 From the **Termination technique** list, choose **Tolerance** to reduce the computational time further.

Shape Optimization

1 In the **Model Builder** window, click **Shape Optimization**.

2 In the **Settings** window for **Shape Optimization**, locate the **Output While Solving** section.

- 3 Select the **Plot** check box.
- 4 From the **Plot group** list, choose **Shape Optimization**.
- 5 In the **Study** toolbar, click  **Compute**.

RESULTS

Shell Geometry (shell), Stress (shell), Thickness and Orientation (shell)

- 1 In the **Model Builder** window, under **Results**, Ctrl-click to select **Stress (shell)**, **Shell Geometry (shell)**, and **Thickness and Orientation (shell)**.

- 2 Right-click and choose **Group**.

Initial Design

In the **Settings** window for **Group**, type Initial Design in the **Label** text field.

Shape Optimization, Shell Geometry (shell) 1, Stress (shell) 1, Thickness and Orientation (shell) 1

- 1 In the **Model Builder** window, under **Results**, Ctrl-click to select **Stress (shell) 1**, **Shell Geometry (shell) 1**, **Thickness and Orientation (shell) 1**, and **Shape Optimization**.

- 2 Right-click and choose **Group**.

Optimized Design

In the **Settings** window for **Group**, type Optimized Design in the **Label** text field.

Applied Loads (shell)

In the **Model Builder** window, under **Results** right-click **Applied Loads (shell)** and choose **Delete**.