

Capacitive Pressure Sensor

Introduction

Capacitive pressure sensors are gaining market share over their piezoresistive counterparts since they consume less power, are usually less temperature sensitive and have a lower fundamental noise floor. This model performs an analysis of a hypothetical sensor design discussed in [Ref. 1](#), using the electromechanics interface. The effect of a rather poor choice of packaging solution on the performance of the sensor is also considered. The results emphasize the importance of considering packaging in the MEMS design process.

Model Definition

The model geometry is shown in [Figure 1](#). The pressure sensor is part of a silicon die that has been bonded to a metal plate at 70 °C. Since the geometry is symmetric, only a single quadrant of the geometry needs to be included in the model, and it is possible to use symmetry boundary condition.

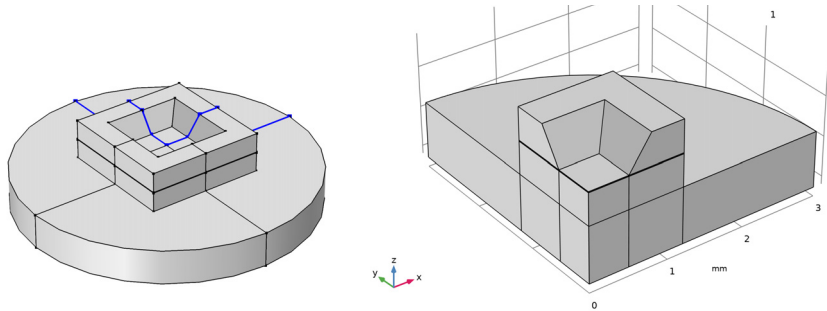

Figure 1: The model geometry. Left: The symmetric device geometry, with one quadrant highlighted in blue, showing the symmetry planes. Right: In COMSOL only the highlighted quadrant is modeled, and the symmetry boundary condition is used on the cross section walls.

A detailed 2D section through the functional part of the device is shown in [Figure 2](#). A thin membrane is held at a fixed potential of 1 V. The membrane is separated from a ground plane chamber sealed under high vacuum. The sides of the chamber are insulating to prevent a connection between the membrane and the ground plane (for simplicity the insulating layer is not modeled explicitly in the COMSOL model; this approximation has little effect on the results of the study.).

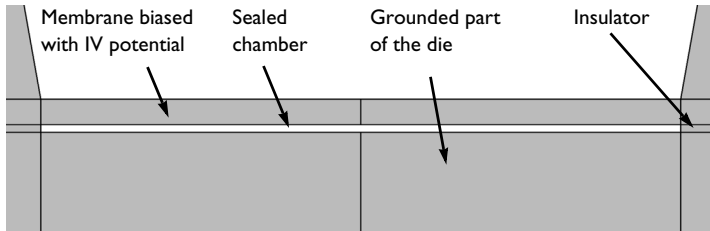

Figure 2: Cross section through the device showing the capacitor. The vertical axis has been expanded to emphasize the gap.

When the pressure outside of the sealed chamber changes, the pressure difference causes the membrane to deflect. The thickness of the sealed chamber now varies across the membrane and its capacitance to ground therefore changes. This capacitance is then monitored by an interfacing circuit, such as the switched capacitor amplifier circuit discussed in [Ref. 1](#).

Thermal stresses are introduced into the structure as a result of the thermal conductivity mismatch between the silicon die and the metal plate, and the elevated temperature used for the bonding process. These stresses change the deformation of the diaphragm in response to applied pressures and alter the response of the sensor. In addition, because the stresses are temperature dependent, they introduce an undesired temperature dependence to the device output.

Initially the sensor is analyzed in the case where there are no packaging stresses. Then the effect of the packaging stress is considered. First, the device response at fixed temperature is evaluated with the additional packaging stress. Finally the temperature dependence of the device response at a fixed applied pressure is assessed.

Results and Discussion

[Figure 3](#) shows the deformation of the membrane when a pressure of 25 kPa is applied to it, in the absence of packaging stresses. [Figure 4](#) shows the potential on a plane located between the plates. The deformation of the membrane is of the form expected, and results in a nonuniform potential between the plates.

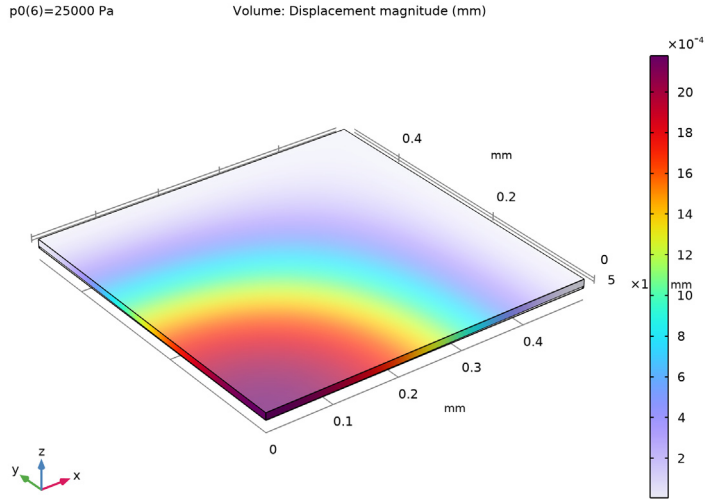

Figure 3: Quadrant deflection when the pressure difference across the membrane is 25 kPa. As expected the deflection is greatest in the center of the membrane.

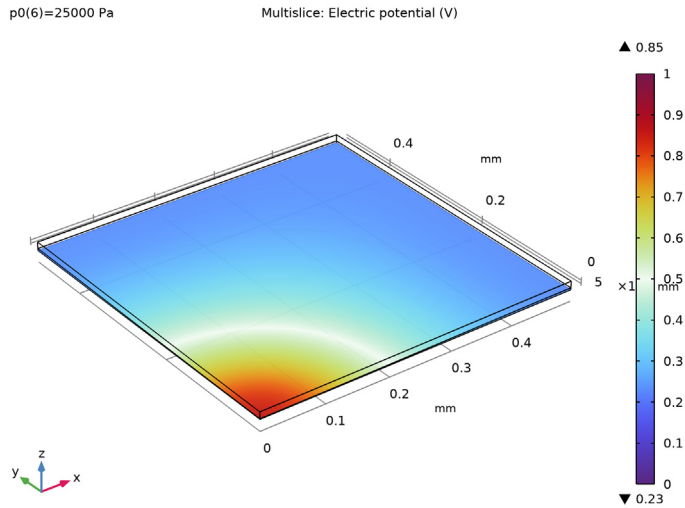

Figure 4: Electric potential in the sealed chamber, plotted on a slice between the two plates of the capacitor. The potential has become nonuniform as a result of the pressure-induced deformation of the diaphragm.

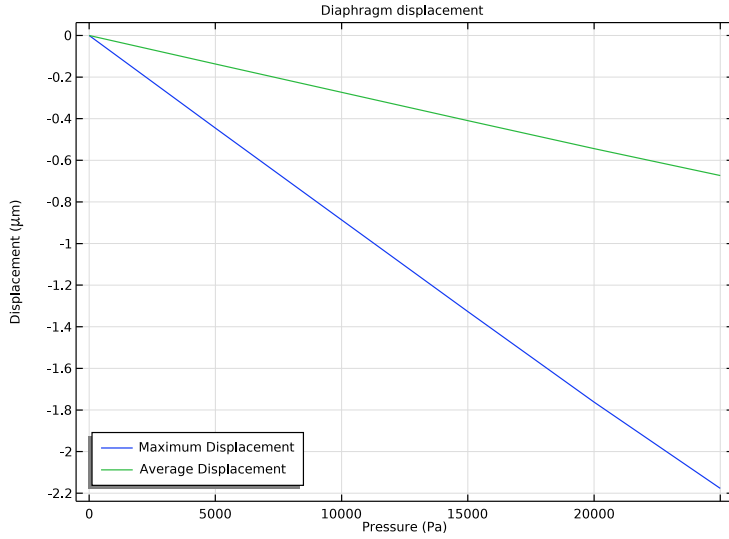

Figure 5: Maximum and mean displacement of the membrane as a function of the applied pressure.

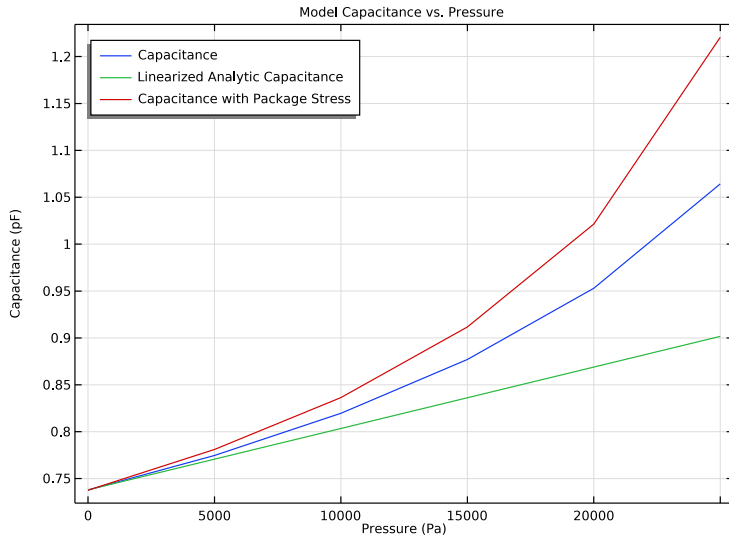

Figure 6: Capacitance of the membrane as a function of applied pressure, both with and without the packaging stresses. The linearized zero pressure capacitance variation, taken from Ref. 1, is also shown for comparison.

Figure 5 shows the mean and maximum displacements of the membrane as a function of applied pressure. At an applied pressure of 10 kPa the diaphragm displacement in the center is 0.89 μm . The average displacement of the diaphragm is 0.27 μm . These values are in good agreement with the approximate model given in Ref. 1 (maximum displacement 0.93 μm , average displacement 0.27 μm).

Figure 6 shows that the capacitance of the device increases nonlinearly with applied pressure. The gradient of the curve plotted is a measure of the sensitivity of the sensor. At zero applied pressure the sensitivity of the model (1/4 of the whole sensor) is $7.3 \cdot 10^{-6}$ pF/Pa (compare to the value of $6.5 \cdot 10^{-6}$ pF/Pa given in Ref. 1). The device sensitivity is therefore $29 \cdot 10^{-6}$ pF/Pa (compare to $26 \cdot 10^{-6}$ pF/Pa. calculated in Ref. 1). Assuming the interfacing electronics use the switched capacitor amplifier circuit presented in Ref. 1 this corresponds to a sensor transfer function of 29 $\mu\text{V}/\text{Pa}$ (compared to 26 $\mu\text{V}/\text{Pa}$ from Ref. 1). Using a smaller pressure step to produce the plot improves the agreement leading to a response at the origin of $6.7 \cdot 10^{-6}$ pF/Pa ($27 \cdot 10^{-6}$ pF/Pa for the device, corresponding to 27 $\mu\text{V}/\text{Pa}$). The response is nonlinear, so that at 20 kPa the model output is $14.3 \cdot 10^{-6}$ pF/Pa (device output 57 pF/Pa or 57 $\mu\text{V}/\text{Pa}$). This nonlinear response adds to the complexity of designing the interfacing circuitry. Note that, for comparison with these figures, the circuitry proposed in Ref. 1, has a noise floor corresponding to a capacitance of $17 \cdot 10^{-6}$ pF, or 0.6 Pa at zero applied pressure (assuming an average of 100 consecutive measurements). This resolution is approximately four times the fundamental sensitivity of the device imposed by mechanical noise from thermal fluctuations.

Next the response of the device is considered when packaging stresses are present in the model. For this part of the discussion it is assumed that the device is operated at 20°C and that the system was stress and displacement free at the bonding temperature (70°C). Figure 7 shows the displacement of the structure at the room temperature operating point, with an applied pressure of 25 kPa. The membrane displacement at its center is shown in Figure 5. The complex interaction between the thermal stresses and the stresses introduced as a result of the applied pressure has resulted in both an initial offset displacement and an increased dependence of the displacement on the pressure.

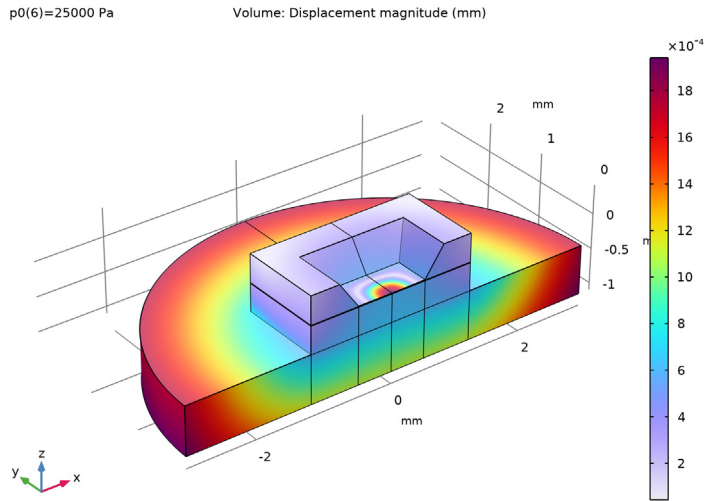

Figure 7: The displacement of the structure due to an applied pressure of 25 kPa when packaging stresses are also included in the model. Displacements are shown at the operating temperature of 20 °C, and are assumed to be zero at the die bonding temperature of 70 °C.

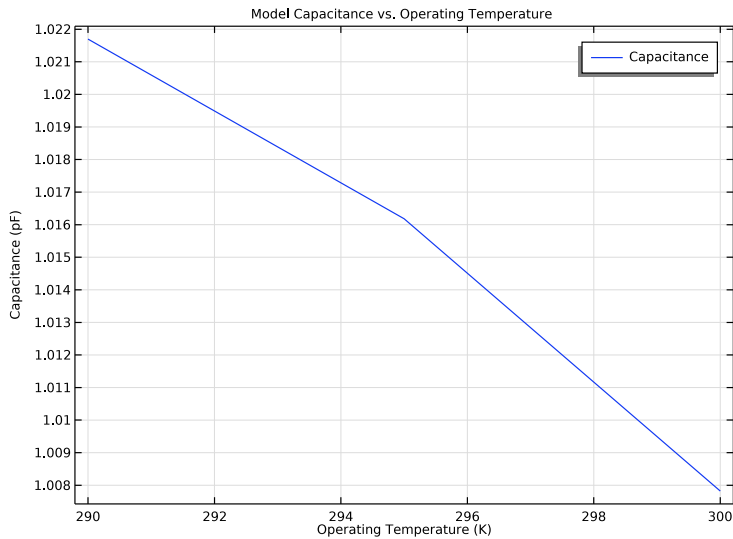

Figure 8: Temperature dependence of the capacitance of the packaged device. The capacitance varies with temperature as a result of temperature induced changes in the packaging stress within the diaphragm.

The response of the device with the additional packaging stresses is shown in [Figure 6](#). At zero applied pressure the sensitivity of the COMSOL model has increased from $6.5 \cdot 10^{-6}$ pF/Pa to $10 \cdot 10^{-6}$ pF/Pa ($40 \cdot 10^{-6}$ pF/Pa for the entire device). The effect is even more pronounced at a pressure of 20 kPa, where the model that includes thermal stresses shows a pressure sensitivity of $25 \cdot 10^{-6}$ pF/Pa (100 pF/Pa for the entire device) compared to the unstressed value of $14.3 \cdot 10^{-6}$ pF/Pa. The sensitivity of the device to pressure has almost doubled. While this effect might seem desirable, an unwanted dependence on temperature has been introduced into the device response. Since the thermal stresses are temperature dependent, the response of the device is also now temperature dependent. The final study in the model assesses this issue.

[Figure 8](#) shows the capacitance of the device, with an applied pressure of 20 kPa, as the temperature is varied. The temperature sensitivity of the model response is given by the gradient of this curve, approximately $3.5 \cdot 10^{-3}$ pF/K ($14 \cdot 10^{-3}$ pF/K for the whole device). With a pressure sensitivity of $25 \cdot 10^{-6}$ pF/Pa at 20 kPa (for a single quadrant of the device) this corresponds to an equivalent pressure of 140 Pa/K in the sensor output. Compared to the unstressed performance of the sensor (0.6 Pa with the circuit proposed in [Ref. 1](#)) this number is very large. The model shows the importance of carefully considering the packaging in the MEMS design process.

Reference

1. V. Kaajakari, *Practical MEMS*, Small Gear Publishing, Las Vegas, 2009.

Application Library path: MEMS_Module/Sensors/capacitive_pressure_sensor

Modeling Instructions

From the **File** menu, choose **New**.



NEW

In the **New** window, click  **Model Wizard**.

MODEL WIZARD

1 In the **Model Wizard** window, click  **3D**.

2 In the **Select Physics** tree, select **Structural Mechanics>Electromagnetics-Structure Interaction>Electromechanics>Electromechanics**.

- 3 Click **Add**.
- 4 Click  **Study**.
- 5 In the **Select Study** tree, select **General Studies>Stationary**.
- 6 Click  **Done**.

GEOMETRY I

For convenience, the device geometry is inserted from an existing file. You can read the instructions for creating the geometry in the [Appendix — Geometry Instructions](#).

- 1 In the **Geometry** toolbar, click **Insert Sequence** and choose **Insert Sequence**.
- 2 Browse to the model's Application Libraries folder and double-click the file `capacitive_pressure_sensor_geom_sequence.mph`.
- 3 In the **Geometry** toolbar, click  **Build All**.

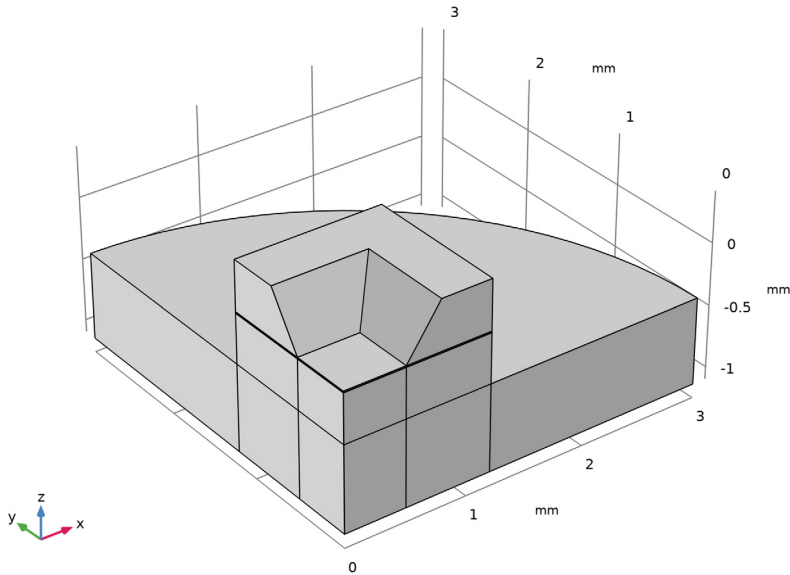

Add parameters to the model. These will be used subsequently to perform parametric studies.

GLOBAL DEFINITIONS

Parameters I

- 1 In the **Model Builder** window, under **Global Definitions** click **Parameters I**.

- 2 In the **Settings** window for **Parameters**, locate the **Parameters** section.
- 3 In the table, enter the following settings:

Name	Expression	Value	Description
p0	20[kPa]	20000 Pa	Pressure
T0	20[degC]	293.15 K	Operating temperature
Tref	70[degC]	343.15 K	Die Bonding temperature

SI units or their multiples, such as Pa and kPa, as well as non-SI units, such as degrees Celsius can be entered in the COMSOL Desktop enclosed by square brackets.

Next, add a nonlocal coupling to compute a derived global quantity from the model. These couplings can be convenient for processing results and COMSOL's solvers can also use them during the solution process, for example to include integral quantities in the equation system. Here, a nonlocal average coupling is added so that the average displacement of the diaphragm can be computed and a point integration is used to make available the displacement of the center point of the diaphragm.

DEFINITIONS

Average 1 (aveop1)

- 1 In the **Definitions** toolbar, click  **Nonlocal Couplings** and choose **Average**.
- 2 In the **Settings** window for **Average**, locate the **Source Selection** section.
- 3 From the **Geometric entity level** list, choose **Boundary**.
- 4 Select Boundary 12 only.

Integration 1 (intop1)

- 1 In the **Definitions** toolbar, click  **Nonlocal Couplings** and choose **Integration**.
- 2 In the **Settings** window for **Integration**, locate the **Source Selection** section.
- 3 From the **Geometric entity level** list, choose **Point**.
- 4 Select Point 4 only.

Next, define selections to simplify the setup of materials and physics.

Steel Base

- 1 In the **Definitions** toolbar, click  **Box**.
- 2 In the **Settings** window for **Box**, locate the **Box Limits** section.
- 3 In the **z maximum** text field, type -100[um].

- 4 Locate the **Output Entities** section. From the **Include entity if** list, choose **Entity inside box**.
- 5 Right-click **Box 1** and choose **Rename**.
- 6 In the **Rename Box** dialog box, type Steel Base in the **New label** text field.
- 7 Click **OK**.



Cavity

- 1 In the **Definitions** toolbar, click  **Explicit**.
- 2 Select Domain 3 only.
- 3 Right-click **Explicit 1** and choose **Rename**.
- 4 In the **Rename Explicit** dialog box, type Cavity in the **New label** text field.
- 5 Click **OK**.

All domains

- 1 In the **Definitions** toolbar, click  **Explicit**.
- 2 In the **Settings** window for **Explicit**, locate the **Input Entities** section.
- 3 Select the **All domains** check box.
- 4 Right-click **Explicit 2** and choose **Rename**.
- 5 In the **Rename Explicit** dialog box, type All domains in the **New label** text field.
- 6 Click **OK**.

Solid

- 1 In the **Definitions** toolbar, click  **Difference**.
- 2 In the **Settings** window for **Difference**, locate the **Input Entities** section.
- 3 Under **Selections to add**, click  **Add**.
- 4 In the **Add** dialog box, select **All domains** in the **Selections to add** list.
- 5 Click **OK**.
- 6 In the **Settings** window for **Difference**, locate the **Input Entities** section.
- 7 Under **Selections to subtract**, click  **Add**.
- 8 In the **Add** dialog box, select **Cavity** in the **Selections to subtract** list.
- 9 Click **OK**.
- 10 Right-click **Difference 1** and choose **Rename**.
- 11 In the **Rename Difference** dialog box, type Solid in the **New label** text field.
- 12 Click **OK**.

Electrostatics

- 1 In the **Definitions** toolbar, click  **Explicit**.
- 2 Select Domains 3 and 4 only.
- 3 In the **Settings** window for **Explicit**, type Electrostatics in the **Label** text field.

SOLID MECHANICS (SOLID)

- 1 In the **Model Builder** window, under **Component 1 (comp1)** click **Solid Mechanics (solid)**.
- 2 In the **Settings** window for **Solid Mechanics**, locate the **Domain Selection** section.
- 3 From the **Selection** list, choose **Solid**.

Apply the structural symmetry boundary condition on the symmetry boundaries.

Symmetry 1

- 1 In the **Physics** toolbar, click  **Boundaries** and choose **Symmetry**.
- 2 In the **Settings** window for **Symmetry**, locate the **Boundary Selection** section.
- 3 From the **Selection** list, choose **XZ Symmetry Plane**.

Symmetry 2

- 1 In the **Physics** toolbar, click  **Boundaries** and choose **Symmetry**.
- 2 In the **Settings** window for **Symmetry**, locate the **Boundary Selection** section.
- 3 From the **Selection** list, choose **YZ Symmetry Plane**.

Note that the electrical symmetry boundary condition (the **Zero Charge** feature) is applied by default.

The motion of the structure is constrained in most directions by the structural symmetry boundary conditions. However, the whole device can still slide up and down the *z*-axis. Apply a point constraint to prevent this.

Prescribed Displacement 1

- 1 In the **Physics** toolbar, click  **Points** and choose **Prescribed Displacement**.
- 2 Select Point 44 only.
- 3 In the **Settings** window for **Prescribed Displacement**, locate the **Prescribed Displacement** section.
- 4 Select the **Prescribed in z direction** check box.

Apply a **Boundary Load** to represent the pressure acting on the surface of the diaphragm.

Boundary Load 1

- 1 In the **Physics** toolbar, click  **Boundaries** and choose **Boundary Load**.
- 2 Select Boundary 13 only.

- 3 In the **Settings** window for **Boundary Load**, locate the **Force** section.
- 4 From the **Load type** list, choose **Pressure**.
- 5 In the p text field, type p_0 .

MOVING MESH

Deforming Domain 1

- 1 In the **Model Builder** window, under **Component 1 (comp1)**>**Moving Mesh** click **Deforming Domain 1**.
- 2 In the **Settings** window for **Deforming Domain**, locate the **Domain Selection** section.
- 3 From the **Selection** list, choose **Cavity**.

Symmetry/Roller 1

- 1 In the **Model Builder** window, click **Symmetry/Roller 1**.

- 2 Select Boundaries 7 and 8 only.

Doing this allows the mesh to move in the z direction.

Add **Terminal** and **Ground** features to the model to apply boundary conditions for the electrostatics parts of the problem.

The default **Charge Conservation** feature was set to use solid material type. Add one more feature to represent the nonsolid (void) domain.

ELECTROSTATICS (ES)

- 1 In the **Model Builder** window, under **Component 1 (comp1)** click **Electrostatics (es)**.
- 2 In the **Settings** window for **Electrostatics**, locate the **Domain Selection** section.
- 3 From the **Selection** list, choose **Electrostatics**.

Charge Conservation 2

- 1 In the **Physics** toolbar, click  **Domains** and choose **Charge Conservation**.
- 2 In the **Settings** window for **Charge Conservation**, locate the **Domain Selection** section.
- 3 From the **Selection** list, choose **Cavity**.

With the assumption that the silicon membrane is a good conductor, use the Domain Terminal feature to set a bias voltage on the domain. Note: The Domain Terminal feature will be very handy for a conducting domain with a complex shape and many exterior boundaries - instead of selecting all the boundaries to set up the Ground, Terminal, or Electric Potential boundary condition, we only need to select the domain to specify the Domain Terminal with the same effect. In addition, the computation load is reduced,

because the electrostatic degrees of freedom within the Domain Terminal do not need to be solved for.

Terminal 1

- 1 In the **Physics** toolbar, click  **Domains** and choose **Terminal**.
- 2 Select Domain 4 only.
- 3 In the **Settings** window for **Terminal**, locate the **Terminal** section.
- 4 From the **Terminal type** list, choose **Voltage**.

The default value of 1 V is fine in this instance.

Ground 1

- 1 In the **Physics** toolbar, click  **Boundaries** and choose **Ground**.
- 2 Select Boundary 9 only.

The pressure sensor consists of a silicon die with an enclosed cavity held at a low pressure. The pressure sensor is bonded onto a cylindrical steel plate during the packaging process. COMSOL includes a **Material Library** with many predefined material properties. This model uses a predefined material for the steel plate, but sets up the silicon as a user-defined material with isotropic material parameters to allow comparison with [Ref. 1](#). The cavity also needs ‘material’ properties (to define the relative permittivity) and a user defined material is used to set the relative permittivity to 1 in this region.

MATERIALS

Silicon

- 1 In the **Model Builder** window, under **Component 1 (comp1)** right-click **Materials** and choose **Blank Material**.
- 2 In the **Settings** window for **Material**, locate the **Material Contents** section.

3 In the table, enter the following settings:

Property	Variable	Value	Unit	Property group
Young's modulus	E	170 [GPa]	Pa	Young's modulus and Poisson's ratio
Poisson's ratio	nu	0.06	I	Young's modulus and Poisson's ratio
Density	rho	2330	kg/m ³	Basic
Relative permittivity	epsilon _{r_1} ; epsilon _{r_2} = epsilon _{r_1} , epsilon _{r_3} = 0	11.7	I	Basic

4 Right-click **Material 1 (mat1)** and choose **Rename**.

5 In the **Rename Material** dialog box, type Silicon in the **New label** text field.

6 Click **OK**.

By default, the silicon is in all domains. Some of these selections will be overridden as other materials are added.

Vacuum

1 In the **Model Builder** window, right-click **Materials** and choose **Blank Material**.

2 In the **Settings** window for **Material**, locate the **Geometric Entity Selection** section.

3 From the **Selection** list, choose **Cavity**.

4 Locate the **Material Contents** section. In the table, enter the following settings:

Property	Variable	Value	Unit	Property group
Relative permittivity	epsilon _{r_1} ; epsilon _{r_2} = epsilon _{r_1} , epsilon _{r_3} = 0	1	I	Basic

5 Click to expand the **Material Properties** section. From the **Material type** list, choose **Nonsolid**.

6 Right-click **Material 2 (mat2)** and choose **Rename**.

7 In the **Rename Material** dialog box, type Vacuum in the **New label** text field.

8 Click **OK**.

ADD MATERIAL

1 In the **Home** toolbar, click  **Add Material** to open the **Add Material** window.

2 Go to the **Add Material** window.

3 In the tree, select **Built-in>Steel AISI 4340**.

4 Click **Add to Component** in the window toolbar.

5 In the **Home** toolbar, click  **Add Material** to close the **Add Material** window.

MATERIALS

Steel AISI 4340 (mat.3)

1 In the **Settings** window for **Material**, locate the **Geometric Entity Selection** section.

2 From the **Selection** list, choose **Steel Base**.

Next set up a structured mesh to solve the problem on.

MESH I

Mapped 1

1 In the **Mesh** toolbar, click  **Boundary** and choose **Mapped**.

2 Select Boundaries 3, 16, and 32 only.

Size 1

1 Right-click **Mapped 1** and choose **Size**.

2 In the **Settings** window for **Size**, locate the **Geometric Entity Selection** section.

3 In the list, select **16**.

4 Click  **Remove from Selection**.

5 Select Boundaries 3 and 32 only.

6 In the list, select **32**.

7 Click  **Remove from Selection**.

8 Select Boundary 3 only.

9 Locate the **Element Size** section. Click the **Custom** button.

10 Locate the **Element Size Parameters** section. Select the **Maximum element size** check box.

11 In the associated text field, type 50[um].

12 Click  **Build All**.

Swept 1

- 1 In the **Mesh** toolbar, click  **Swept**.
- 2 In the **Settings** window for **Swept**, click  **Build All**.

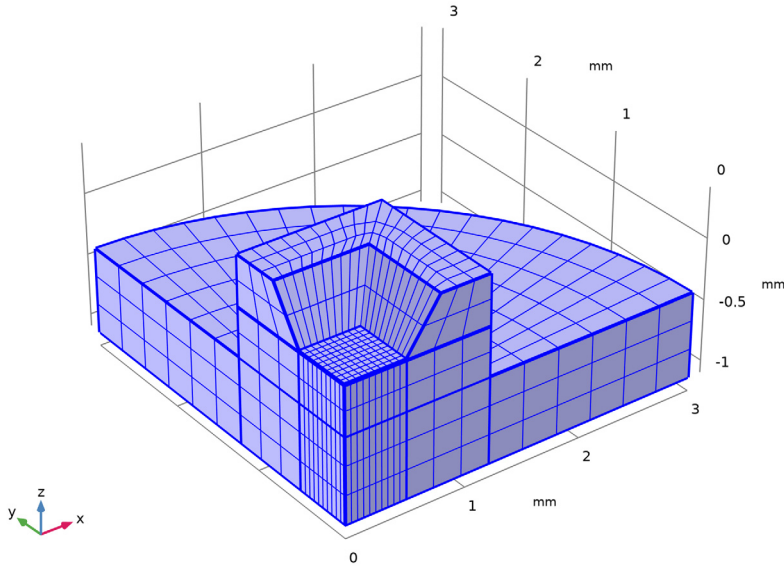

Set up a study that sweeps over a range of applied pressures, so that the response of the sensor can be assessed.

STUDY 1

Step 1: Stationary

- 1 In the **Model Builder** window, under **Study 1** click **Step 1: Stationary**.
- 2 In the **Settings** window for **Stationary**, click to expand the **Study Extensions** section.
- 3 Select the **Auxiliary sweep** check box.

- 4 Click  **Add**.

The continuation parameter p_0 (Pressure) is added by default. This is the correct parameter to sweep over.

- 5 Click  **Range**.
- 6 In the **Range** dialog box, type 0 in the **Start** text field.
- 7 In the **Step** text field, type 5000.
- 8 In the **Stop** text field, type 25000.

9 Click **Add**.

10 In the **Home** toolbar, click  **Compute**.

RESULTS

Displacement (solid)

Much of the structure is not displaced in this initial study. To facilitate results analysis, add a selection to the solution. This will ensure that only the domains of interest are displayed in the plots.

Study 1/Solution 1 (sol1)

In the **Model Builder** window, expand the **Results>Datasets** node, then click **Study 1/Solution 1 (sol1)**.

Selection

- 1 In the **Results** toolbar, click  **Attributes** and choose **Selection**.
- 2 In the **Settings** window for **Selection**, locate the **Geometric Entity Selection** section.
- 3 From the **Geometric entity level** list, choose **Domain**.
- 4 From the **Selection** list, choose **Electrostatics**.

Displacement (solid)

1 Click the  **Zoom Extents** button in the **Graphics** toolbar.

p0(6)=25000 Pa

Volume: Displacement magnitude (mm)

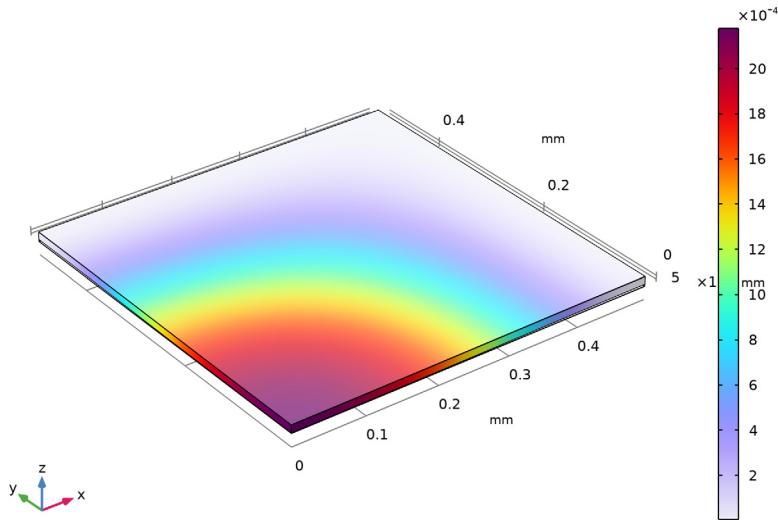

The plot now shows the displacement of the diaphragm only, which, as expected, is maximum in the center of the sensor.

Next, plot the electric potential in an xy -orientated plane between the sensor diaphragm and the ground plane.

Streamline Multislice 1

- 1 In the **Model Builder** window, expand the **Results>Electric Potential (es)** node.
- 2 Right-click **Results>Electric Potential (es)>Streamline Multislice 1** and choose **Delete**.

Multislice 1

- 1 In the **Model Builder** window, under **Results>Electric Potential (es)** click **Multislice 1**.
- 2 In the **Settings** window for **Multislice**, locate the **Multiplane Data** section.
- 3 Find the **x-planes** subsection. From the **Entry method** list, choose **Number of planes**.
- 4 In the **Planes** text field, type 0.
- 5 Find the **y-planes** subsection. From the **Entry method** list, choose **Number of planes**.
- 6 In the **Planes** text field, type 0.
- 7 Find the **z-planes** subsection. In the **Coordinates** text field, type -0.0023 [mm].

8 Click to expand the **Range** section. Select the **Manual color range** check box.

Selection 1

- 1 Right-click **Multislice 1** and choose **Selection**.
- 2 In the **Settings** window for **Selection**, locate the **Selection** section.
- 3 From the **Selection** list, choose **Cavity**.
- 4 In the **Electric Potential (es)** toolbar, click  **Plot**.

Due to the deformation of the diaphragm the potential is nonuniformly distributed in the plane.

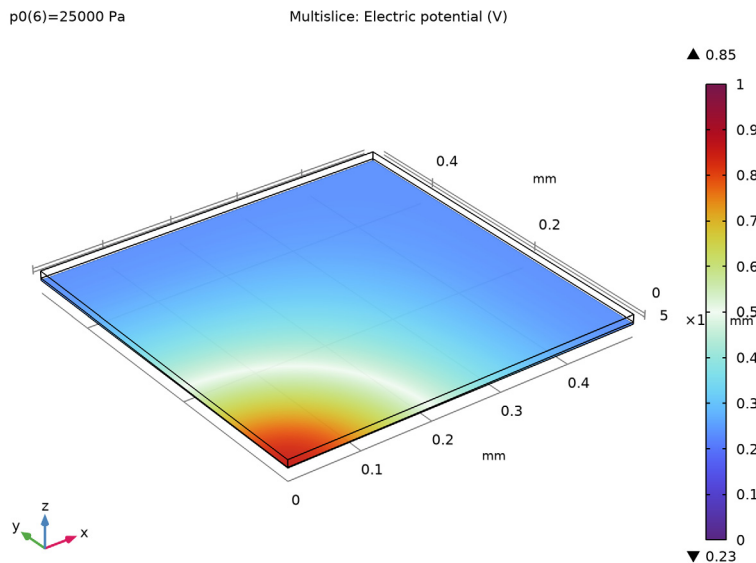

Next, plot the deformation of the diaphragm as a function of the pressure differential across it. Include both average and maximum displacements.

ID Plot Group 5

In the **Home** toolbar, click  **Add Plot Group** and choose **ID Plot Group**.

Global 1

- 1 Right-click **ID Plot Group 5** and choose **Global**.
Use the point integration and surface average couplings defined earlier to evaluate the displacement at the midpoint of the membrane and the average displacement.
- 2 In the **Settings** window for **Global**, locate the **y-Axis Data** section.

3 In the table, enter the following settings:

Expression	Unit	Description
intop1(w)	um	Maximum Displacement
aveop1(w)	um	Average Displacement

Diaphragm Displacement vs. Pressure

- 1 In the **Model Builder** window, click **ID Plot Group 5**.
- 2 In the **Settings** window for **ID Plot Group**, click to expand the **Title** section.
- 3 From the **Title type** list, choose **Manual**.
- 4 In the **Title** text area, type Diaphragm displacement.
- 5 Locate the **Plot Settings** section. Select the **x-axis label** check box.
- 6 In the associated text field, type Pressure (Pa).
- 7 Select the **y-axis label** check box.
- 8 In the associated text field, type Displacement (μm).
- 9 Locate the **Legend** section. From the **Position** list, choose **Lower left**.
- 10 Right-click **ID Plot Group 5** and choose **Rename**.
- 11 In the **Rename ID Plot Group** dialog box, type Diaphragm Displacement vs. Pressure in the **New label** text field.
- 12 Click **OK**.

B In the **Diaphragm Displacement vs. Pressure** toolbar, click  **Plot**.

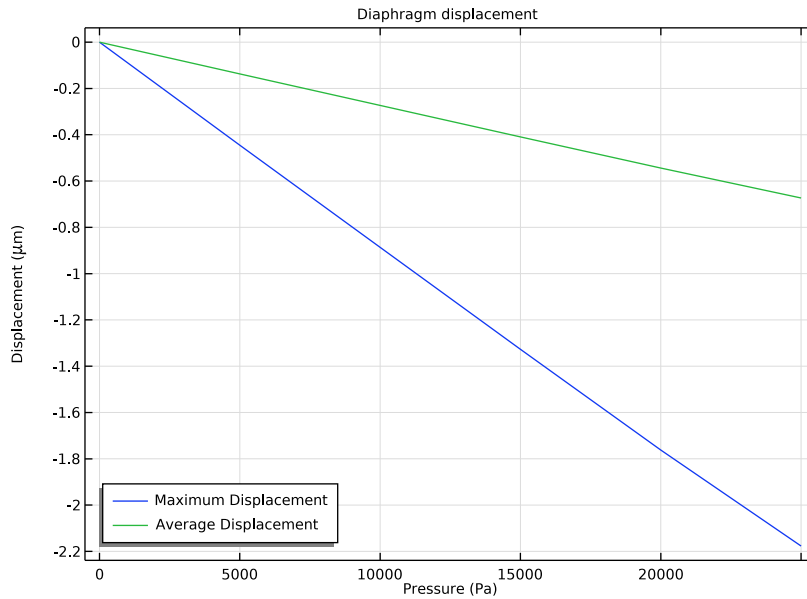

At an applied pressure of 10 kPa the diaphragm displacement in the center is 0.89 μm . The average displacement of the diaphragm is 0.27 μm . These values are in good agreement with the approximate model given in [Ref. 1](#) (maximum displacement 0.93 μm , average displacement 0.27 μm).

Now plot the sensor capacitance as a function of the applied pressure. If the switched capacitor amplifier described in [Ref. 1](#) is used to produce the output, the sensor output or transfer function is directly proportional to the change in capacitance.

ID Plot Group 6

In the **Home** toolbar, click  **Add Plot Group** and choose **ID Plot Group**.

Global 1

I Right-click **ID Plot Group 6** and choose **Global**.

Since the **Terminal** boundary condition was used for the underside of the diaphragm, COMSOL automatically computes its capacitance with respect to ground. The value of the capacitance is available as a variable in results analysis.

- 2 In the **Settings** window for **Global**, click **Replace Expression** in the upper-right corner of the **y-Axis Data** section. From the menu, choose **Component 1 (comp1)>Electrostatics>Terminals>es.C11 - Maxwell capacitance - F**.

Next, compare the computed capacitance with the small-displacement, linearized analytic expression derived in [Ref. 1](#).

- 3 Locate the **y-Axis Data** section. In the table, enter the following settings:

Expression	Unit	Description
es.C11	pF	Capacitance
$0.738[\text{pF}] * (1 + 8.87\text{e-}6[1/\text{Pa}] * p_0)$	pF	Linearized Analytic Capacitance

Model Capacitance vs. Pressure

- 1 In the **Model Builder** window, click **ID Plot Group 6**.
- 2 In the **Settings** window for **ID Plot Group**, locate the **Title** section.
- 3 From the **Title type** list, choose **Manual**.
- 4 In the **Title** text area, type **Model Capacitance vs. Pressure**.
- 5 Locate the **Plot Settings** section. Select the **x-axis label** check box.
- 6 In the associated text field, type **Pressure (Pa)**.
- 7 Select the **y-axis label** check box.
- 8 In the associated text field, type **Capacitance (pF)**.
- 9 Locate the **Legend** section. From the **Position** list, choose **Upper left**.
- 10 Right-click **ID Plot Group 6** and choose **Rename**.

The capacitance of the sensor increases with applied pressure. The gradient of the curve plotted gives a useful measure of the response of the device. At the origin, the response of the model (1/4 of the whole sensor) is $7\text{e-}6$ pF/Pa, compared to the analytical response of $6.5\text{e-}6$ pf/Pa. The response for the whole sensor is $29\text{e-}6$ pF/Pa compared to the analytic value of $26\text{e-}6$ pF/Pa. With the measurement circuit proposed in [Ref. 1](#) this corresponds to a sensor transfer function of 29 $\mu\text{V}/\text{Pa}$ for the COMSOL model and 26 $\mu\text{V}/\text{Pa}$ for the simple analytic model. The response is nonlinear, so that at 20 kPa the model output is $14\text{e-}6$ pf/Pa (device output 57 pF/Pa).

- 11 In the **Rename ID Plot Group** dialog box, type **Model Capacitance vs. Pressure** in the **New label** text field.
- 12 Click **OK**.

13 In the **Model Capacitance vs. Pressure** toolbar, click  **Plot**.

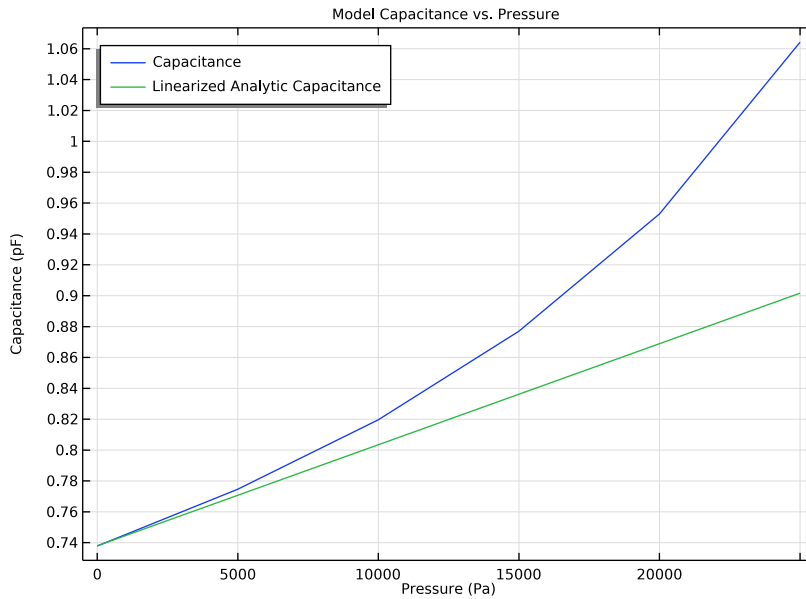

Next, add thermal expansion to the model to assess the effects of packaging stresses on the device performance.

SOLID MECHANICS (SOLID)

Linear Elastic Material 1

In the **Model Builder** window, under **Component 1 (comp1)>Solid Mechanics (solid)** click **Linear Elastic Material 1**.

Thermal Expansion 1

1 In the **Physics** toolbar, click  **Attributes** and choose **Thermal Expansion**.

The model temperature should be set to the previously defined room temperature parameter, T_0 .

2 In the **Settings** window for **Thermal Expansion**, locate the **Model Input** section.

3 From the T list, choose **User defined**. In the associated text field, type T_0 .

The reference temperature indicates the temperature at which the structure had no thermal strains. In this case, set it to the previously defined parameter, T_{ref} , which represents the temperature at which the silicon die was bonded to the metal carrier plate.

- 4 Click  **Go to Source** for **Volume reference temperature**.

GLOBAL DEFINITIONS

Default Model Inputs

- 1 In the **Model Builder** window, under **Global Definitions** click **Default Model Inputs**.
- 2 In the **Settings** window for **Default Model Inputs**, locate the **Browse Model Inputs** section.
- 3 Find the **Expression for remaining selection** subsection. In the **Volume reference temperature** text field, type Tref.



MATERIALS

Silicon (mat1)

COMSOL shows a warning in the material properties settings to indicate a missing property.

- 1 In the **Model Builder** window, under **Component 1 (comp1)>Materials** click **Silicon (mat1)**.
- 2 In the table, add a value for the thermal expansivity of silicon to the appropriate row:
Add a new study to compute the system response including thermal expansivity effects.

ADD STUDY

- 1 In the **Home** toolbar, click  **Add Study** to open the **Add Study** window.
- 2 Go to the **Add Study** window.
- 3 Find the **Studies** subsection. In the **Select Study** tree, select **General Studies>Stationary**.
- 4 Click **Add Study** in the window toolbar.
- 5 In the **Home** toolbar, click  **Add Study** to close the **Add Study** window.

STUDY 2

- 1 In the **Model Builder** window, click **Study 2**.
- 2 In the **Settings** window for **Study**, locate the **Study Settings** section.
- 3 Clear the **Generate default plots** check box.

Step 1: Stationary

- 1 In the **Model Builder** window, under **Study 2** click **Step 1: Stationary**.
- 2 In the **Settings** window for **Stationary**, locate the **Study Extensions** section.
- 3 Select the **Auxiliary sweep** check box.

4 Click  **Add**.

The continuation parameter p_0 (Differential Pressure) is added by default. This is the correct parameter to sweep over.

5 Click  **Range**.

6 In the **Range** dialog box, type 0 in the **Start** text field.

7 In the **Step** text field, type 5000.

8 In the **Stop** text field, type 25000.

9 Click **Add**.

10 In the **Home** toolbar, click  **Compute**.

Create a mirrored dataset to visualize a cross section of the device.

RESULTS

Mirror 3D 1

1 In the **Results** toolbar, click  **More Datasets** and choose **Mirror 3D**.

2 In the **Settings** window for **Mirror 3D**, locate the **Data** section.

3 From the **Dataset** list, choose **Study 2/Solution 2 (sol2)**.

Displacement (solid) 1

1 In the **Model Builder** window, right-click **Displacement (solid)** and choose **Duplicate**.

2 In the **Settings** window for **3D Plot Group**, locate the **Data** section.

3 From the **Dataset** list, choose **Mirror 3D 1**.

4 In the **Displacement (solid) 1** toolbar, click  **Plot**.

Notice that the entire structure is now displaced at room temperature as a result of thermal expansion.

p0(6)=25000 Pa

Volume: Displacement magnitude (mm)

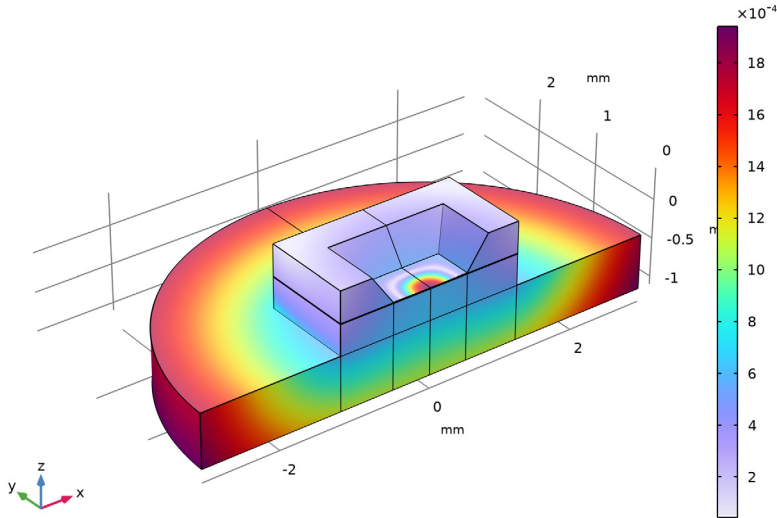

Now look at the effect of the thermal stress on the response of the sensor.

Add an additional **Global** node to the previously defined plot. This separate node can point to a different dataset, enabling a plot of the displacement of the thermally stressed device alongside the unstressed plot.

Global 2

- 1 In the **Model Builder** window, under **Results>Diaphragm Displacement vs. Pressure** right-click **Global 1** and choose **Duplicate**.
- 2 In the **Settings** window for **Global**, locate the **Data** section.
- 3 From the **Dataset** list, choose **Study 2/Solution 2 (sol2)**.

Note that the `aveop1(w)` expression has been removed from the table.

4 In the **Diaphragm Displacement vs. Pressure** toolbar, click  **Plot**.

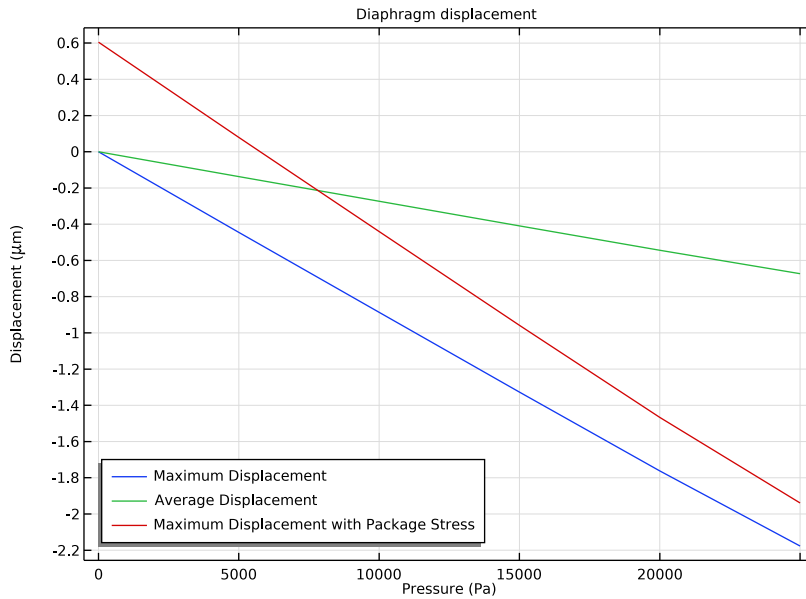

The maximum displacement of the membrane is now nonzero at zero applied pressure, as a result of the packaging stress. The gradient of the displacement-pressure line has also changed.

Model Capacitance vs. Pressure

Now add the thermally stressed results to the Capacitance versus Pressure plot.

Global 2

- 1 In the **Model Builder** window, right-click **Model Capacitance vs. Pressure** and choose **Global**.
- 2 In the **Settings** window for **Global**, locate the **Data** section.
- 3 From the **Dataset** list, choose **Study 2/Solution 2 (sol2)**.
- 4 Click **Replace Expression** in the upper-right corner of the **y-Axis Data** section. From the menu, choose **Component 1 (comp1)>Electrostatics>Terminals>es.C11 - Maxwell capacitance - F**.
- 5 Locate the **y-Axis Data** section. In the table, enter the following settings:

Expression	Unit	Description
es.C11	pF	Capacitance with Package Stress

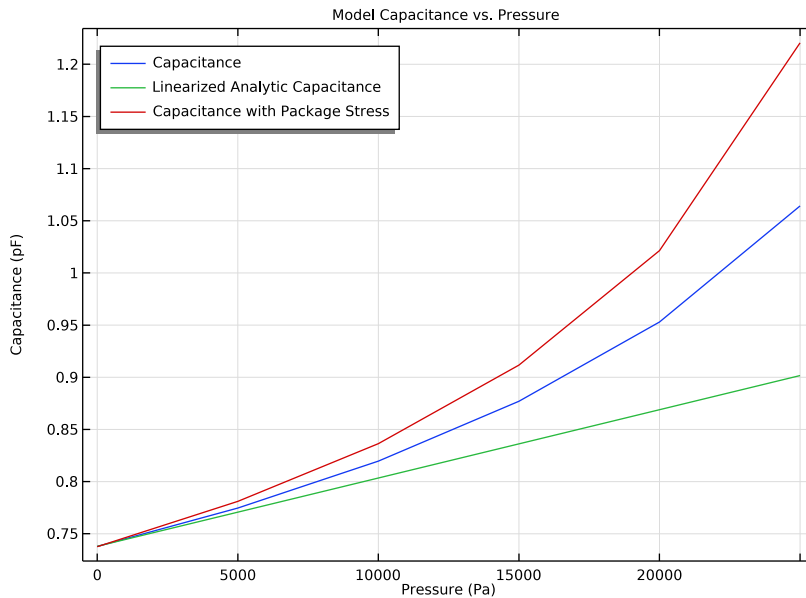

6 In the **Model Capacitance vs. Pressure** toolbar, click  **Plot**.

The packaging stress causes a significant change in the response of the device. At zero applied pressure the sensitivity of the COMSOL model has increased to 10×10^{-6} pF/Pa (40×10^{-6} pF/Pa for the entire device). Compare to the unstressed value of 6.5×10^{-6} pf/Pa (29×10^{-6} pF/Pa for the entire device). The effect is even more pronounced at a pressure of 20 kPa, where the model that includes thermal stresses shows a pressure sensitivity of 25×10^{-6} pf/Pa (100 pF/Pa for the entire device), compared to the unstressed pressure sensitivity of 14.3×10^{-6} pf/Pa (sensor output 57 pF/Pa).





It may be possible to calibrate the device to remove the effect of the packaging strains. However, the addition of the thermal stresses to the system has created an additional issue, since the response of the sensor has now become temperature dependent - due to the temperature sensitivity of the thermal strains. This effect is assessed in the final study.

ADD STUDY

- 1 In the **Home** toolbar, click  **Add Study** to open the **Add Study** window.
- 2 Go to the **Add Study** window.
- 3 Find the **Studies** subsection. In the **Select Study** tree, select **General Studies>Stationary**.
- 4 Click **Add Study** in the window toolbar.
- 5 In the **Home** toolbar, click  **Add Study** to close the **Add Study** window.

STUDY 3

Step 1: Stationary

- 1 In the **Settings** window for **Stationary**, locate the **Study Extensions** section.
- 2 Select the **Auxiliary sweep** check box.
Sweep over operating temperature at constant applied pressure, to assess the temperature sensitivity of the device.
- 3 Click  **Add**.
- 4 From the list in the **Parameter name** column, choose **T0 (Operating temperature)**.
- 5 Click  **Range**.
- 6 In the **Range** dialog box, type 290 in the **Start** text field.
- 7 In the **Step** text field, type 5.
- 8 In the **Stop** text field, type 300.
- 9 Click **Add**.

For this study disable the default plots, as these will be very similar to those already generated by **Study 2**.

- 10 In the **Model Builder** window, click **Study 3**.
- 11 In the **Settings** window for **Study**, locate the **Study Settings** section.
- 12 Clear the **Generate default plots** check box.
- 13 In the **Home** toolbar, click  **Compute**.

Add a plot to show how the sensor response varies with temperature. The response is computed at an applied pressure set by the value of the parameter p_0 , defined as 20 kPa.

RESULTS

ID Plot Group 8

- 1 In the **Home** toolbar, click  **Add Plot Group** and choose **ID Plot Group**.
- 2 In the **Settings** window for **ID Plot Group**, locate the **Data** section.
- 3 From the **Dataset** list, choose **Study 3/Solution 3 (sol3)**.

Global 1

- 1 Right-click **ID Plot Group 8** and choose **Global**.
- 2 In the **Settings** window for **Global**, click **Replace Expression** in the upper-right corner of the **y-Axis Data** section. From the menu, choose **Component 1 (comp1)>Electrostatics>Terminals>es.C11 - Maxwell capacitance - F**.

3 Locate the **y-Axis Data** section. In the table, enter the following settings:

Expression	Unit	Description
es.C11	pF	Capacitance

Capacitance vs. Operating Temperature

- 1 In the **Model Builder** window, click **ID Plot Group 8**.
- 2 In the **Settings** window for **ID Plot Group**, locate the **Title** section.
- 3 From the **Title type** list, choose **Manual**.
- 4 In the **Title** text area, type Model Capacitance vs. Operating Temperature.
- 5 Locate the **Plot Settings** section. Select the **x-axis label** check box.
- 6 In the associated text field, type Operating Temperature (K).
- 7 Right-click **ID Plot Group 8** and choose **Rename**.
- 8 In the **Rename ID Plot Group** dialog box, type Capacitance vs. Operating Temperature in the **New label** text field.
- 9 Click **OK**.
- 10 In the **Capacitance vs. Operating Temperature** toolbar, click  **Plot**.

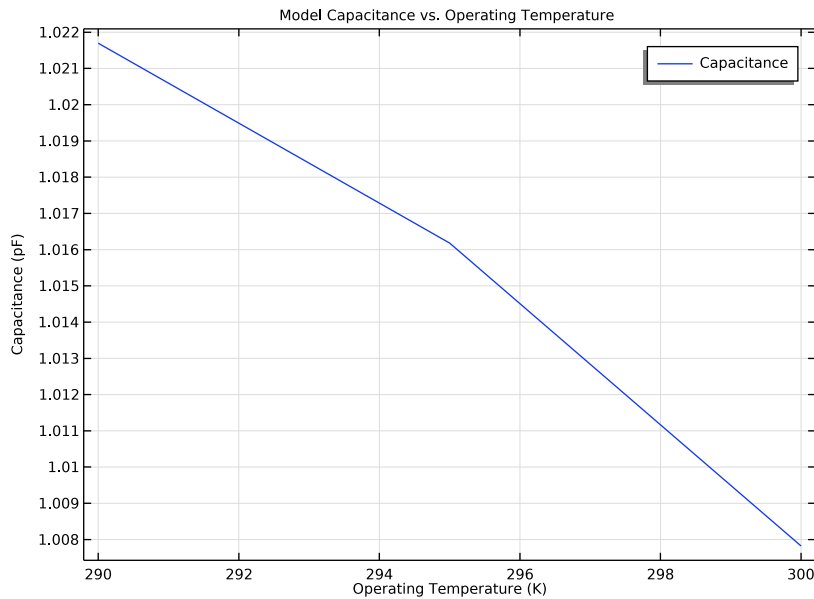

At a pressure of 20 kPa the temperature sensitivity of the model is given by the gradient of this curve, approximately 3.5×10^{-3} pF/K (1.4×10^{-4} pF/K for the whole device). Given the

pressure sensitivity of $25e-6$ pF/Pa at 20 kPa this corresponds to equivalent pressure of 140 Pa/K in the sensor output. Compared to the noise floor of the measuring circuit proposed in Ref. 1 (0.6Pa) this number is very large. This model shows that a naive choice of packaging can have a highly detrimental effect on sensor performance.

Appendix — Geometry Instructions

From the **File** menu, choose **New**.

NEW

In the **New** window, click  **Blank Model**.

ADD COMPONENT

In the **Home** toolbar, click  **Add Component** and choose **3D**.

GEOMETRY 1

- 1 In the **Settings** window for **Geometry**, locate the **Units** section.
- 2 From the **Length unit** list, choose **mm**.

Block 1 (blk1)

- 1 In the **Geometry** toolbar, click  **Block**.
- 2 In the **Settings** window for **Block**, locate the **Size and Shape** section.
- 3 In the **Width** text field, type 1.2.
- 4 In the **Depth** text field, type 1.2.
- 5 In the **Height** text field, type 1.51.
- 6 Locate the **Position** section. In the **z** text field, type -1.1.
- 7 Click to expand the **Layers** section. In the table, enter the following settings:

Layer name	Thickness (mm)
Layer 1	0.7
Layer 2	0.397
Layer 3	0.003
Layer 4	0.01

Block 2 (blk2)

- 1 In the **Geometry** toolbar, click  **Block**.

- 2 In the **Settings** window for **Block**, locate the **Size and Shape** section.
- 3 In the **Width** text field, type 0.5.
- 4 In the **Depth** text field, type 0.5.
- 5 In the **Height** text field, type 1.51.
- 6 Locate the **Position** section. In the **z** text field, type -1.1.

Partition Domains 1 (pard1)

- 1 In the **Geometry** toolbar, click  **Booleans and Partitions** and choose **Partition Domains**.
- 2 On the object **blk1**, select Domains 1–4 only.
- 3 In the **Settings** window for **Partition Domains**, locate the **Partition Domains** section.
- 4 From the **Partition with** list, choose **Objects**.
- 5 Select the object **blk2** only.

Hexahedron 1 (hex1)

- 1 In the **Geometry** toolbar, click  **More Primitives** and choose **Hexahedron**.
- 2 In the **Settings** window for **Hexahedron**, locate the **Vertices** section.
- 3 In row **2**, set **x** to 0.5.
- 4 In row **3**, set **x** to 0.5.
- 5 In row **4**, set **x** to 0.
- 6 In row **6**, set **x** to 0.78322.
- 7 In row **7**, set **x** to 0.78322.
- 8 In row **8**, set **x** to 0.
- 9 In row **2**, set **y** to 0.
- 10 In row **3**, set **y** to 0.5.
- 11 In row **4**, set **y** to 0.5.
- 12 In row **6**, set **y** to 0.
- 13 In row **7**, set **y** to 0.78322.
- 14 In row **8**, set **y** to 0.78322.
- 15 In row **1**, set **z** to 0.01.
- 16 In row **2**, set **z** to 0.01.
- 17 In row **3**, set **z** to 0.01.
- 18 In row **4**, set **z** to 0.01.



19 In row **5**, set **z** to 0.41.

20 In row **6**, set **z** to 0.41.

21 In row **7**, set **z** to 0.41.

22 In row **8**, set **z** to 0.41.



Difference 1 (dif1)

- 1** In the **Geometry** toolbar, click  **Booleans and Partitions** and choose **Difference**.
- 2** Select the object **pard1** only.
- 3** In the **Settings** window for **Difference**, locate the **Difference** section.
- 4** Find the **Objects to subtract** subsection. Click to select the  **Activate Selection** toggle button.
- 5** Select the object **hex1** only.

Cylinder 1 (cyl1)

- 1** In the **Geometry** toolbar, click  **Cylinder**.
- 2** In the **Settings** window for **Cylinder**, locate the **Size and Shape** section.
- 3** In the **Radius** text field, type 3.
- 4** In the **Height** text field, type 0.7.
- 5** Locate the **Position** section. In the **z** text field, type -1.1.

Partition Domains 2 (pard2)

- 1** In the **Geometry** toolbar, click  **Booleans and Partitions** and choose **Partition Domains**.
- 2** On the object **cyl1**, select Domain 1 only.
- 3** In the **Settings** window for **Partition Domains**, locate the **Partition Domains** section.
- 4** From the **Partition with** list, choose **Extended faces**.
- 5** On the object **dif1**, select Boundaries 17 and 38 only.
- 6** In the tree, select **dif1**.
- 7** Click  **Build Selected**.

Delete Entities 1 (del1)

- 1** In the **Geometry** toolbar, click  **Delete**.
- 2** In the **Settings** window for **Delete Entities**, locate the **Entities or Objects to Delete** section.
- 3** From the **Geometric entity level** list, choose **Domain**.
- 4** On the object **blk2**, select Domain 1 only.

5 On the object **pard2**, select Domains 1–3 only.

Form Union (fin)

- 1 In the **Model Builder** window, click **Form Union (fin)**.
- 2 In the **Settings** window for **Form Union/Assembly**, click  **Build Selected**.

YZ Symmetry Plane

- 1 In the **Geometry** toolbar, click  **Selections** and choose **Explicit Selection**.
- 2 In the **Settings** window for **Explicit Selection**, type YZ Symmetry Plane in the **Label** text field.
- 3 Locate the **Entities to Select** section. From the **Geometric entity level** list, choose **Boundary**.
- 4 Select the **Group by continuous tangent** check box.
- 5 On the object **fin**, select Boundaries 1, 4, 7, 10, 14, 17, 20, 23, 26, and 30 only.

XZ Symmetry Plane

- 1 In the **Geometry** toolbar, click  **Selections** and choose **Explicit Selection**.
- 2 In the **Settings** window for **Explicit Selection**, type XZ Symmetry Plane in the **Label** text field.
- 3 Locate the **Entities to Select** section. From the **Geometric entity level** list, choose **Boundary**.
- 4 Select the **Group by continuous tangent** check box.
- 5 On the object **fin**, select Boundaries 2, 5, 8, 11, 40, 42, 44, 46, 48, and 50 only.

Steel Base

- 1 In the **Geometry** toolbar, click  **Selections** and choose **Box Selection**.
- 2 In the **Settings** window for **Box Selection**, type Steel Base in the **Label** text field.
- 3 Locate the **Box Limits** section. In the **z maximum** text field, type -0.1.
- 4 Locate the **Output Entities** section. From the **Include entity if** list, choose **Entity inside box**.

Cavity

- 1 In the **Geometry** toolbar, click  **Selections** and choose **Explicit Selection**.
- 2 In the **Settings** window for **Explicit Selection**, type Cavity in the **Label** text field.
- 3 On the object **fin**, select Domain 3 only.

Geometry

- 1 In the **Geometry** toolbar, click  **Selections** and choose **Explicit Selection**.

- 2 In the **Settings** window for **Explicit Selection**, type Geometry in the **Label** text field.
- 3 Locate the **Entities to Select** section. From the **Geometric entity level** list, choose **Object**.
- 4 Select the object **fin** only.

Linear Elastic

- 1 In the **Geometry** toolbar, click  **Selections** and choose **Difference Selection**.
- 2 In the **Settings** window for **Difference Selection**, type Linear Elastic in the **Label** text field.
- 3 Locate the **Input Entities** section. Click **+ Add**.
- 4 In the **Add** dialog box, select **Geometry** in the **Selections to add** list.
- 5 Click **OK**.
- 6 In the **Settings** window for **Difference Selection**, locate the **Input Entities** section.
- 7 Click **+ Add**.
- 8 In the **Add** dialog box, select **Cavity** in the **Selections to subtract** list.
- 9 Click **OK**.